

Assembly Instructions

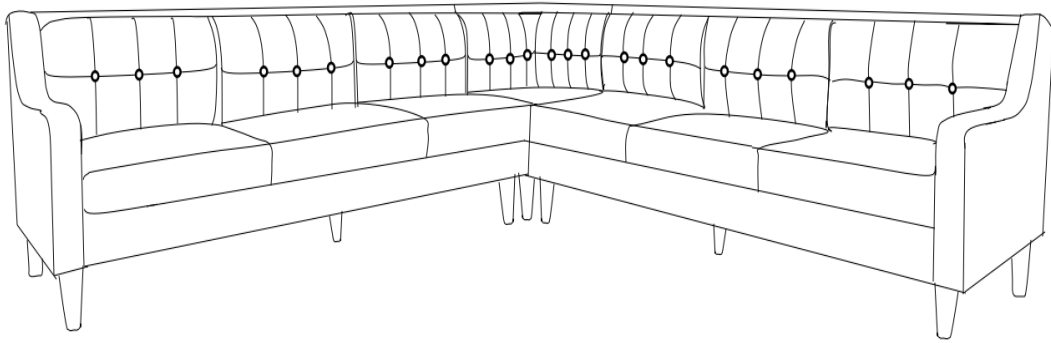

Caution: You must read this before you proceed





Please look in the small box for hardware packs and legs.

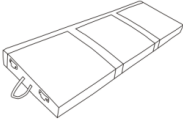
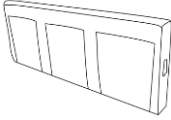
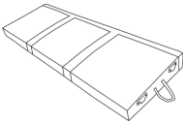
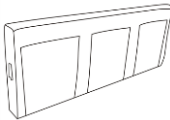

Sectional Sofa

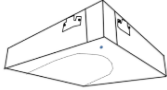

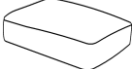

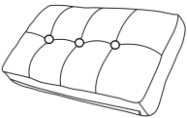
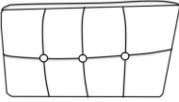
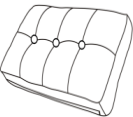

Parts List

Label	Picture	Description	QTY(pc)
A		Left Sofa Seat Base	1
B		Left Sofa Backrest	1
C		Right Sofa Seat Base	1
D		Right Sofa Backrest	1
E		Corner Right Backrest	1
F		Corner Left Backrest	1

G		Corner Seat Base	1
H		Sofa Seat Cushion	6
I		Corner Seat Cushion	1
J		Left Arm	1
K		Right Arm	1

L		Sofa Back Cushion	6
M		Corner Left Big Back Cushion	1
N		Corner Right Small Back Cushion	1
O		Wooden Leg with 1 Plastic Gasket	14

Hardware List

Label	Picture	Description	QTY
①		Plastic Gasket	20
②		Allen Wrench	2
③		Spring Ring	19
④		Flat Gasket	19
⑤		Bolt(M8*70mm)	19

Assembly Preparation

Before Beginning Assembly:

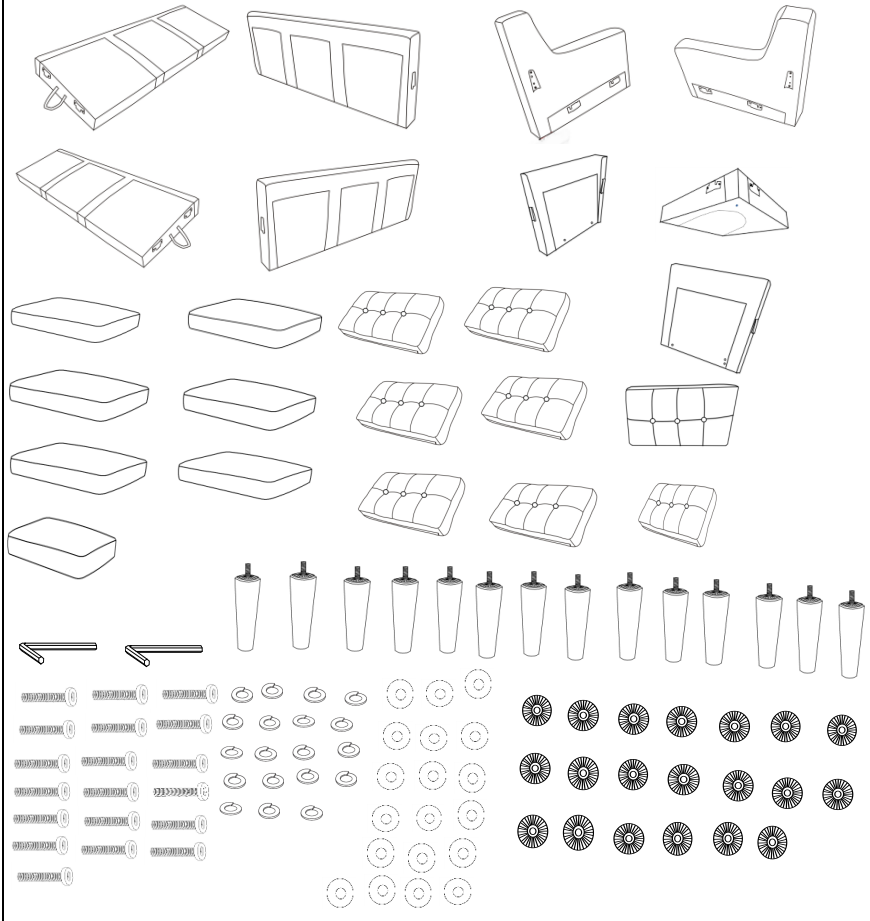

- Read instructions, cover to cover-



- Have 2 adults on hand for assembly-



- Do not assemble on flooring or carpet-



- Assemble on a clean non-marring surface (packing foam)-



- Save all packaging until finished-

Assembly Steps

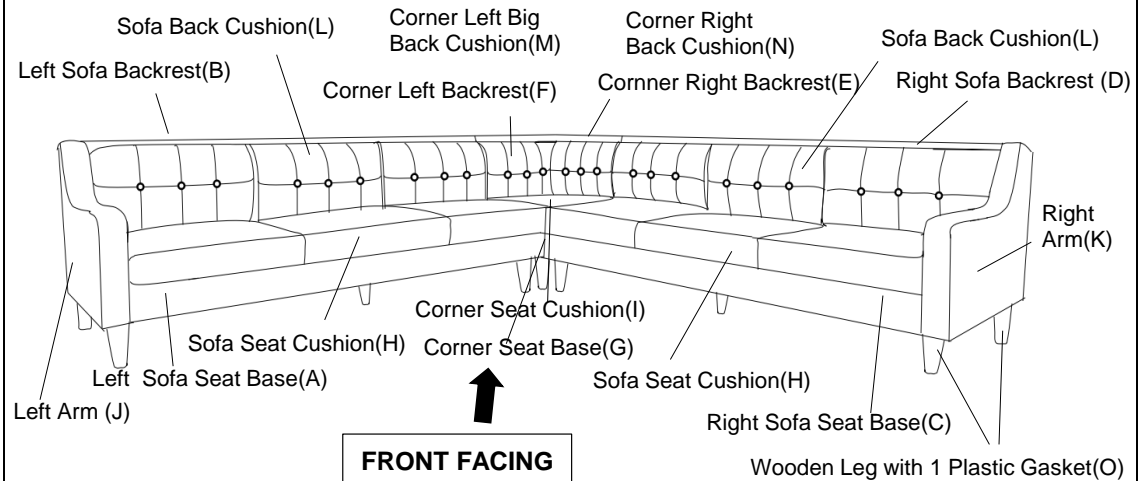

This Sofa has multiple parts and may require about 60 minutes to assemble. To give you an overview of the Sofa parts, the above picture is to help you put the various parts into perspective. Please read through the instructions below to familiarise yourself with the parts and steps before assembly.

Note: It is recommended that you have an adult partner to assist during the entire assembly process.

Step 1

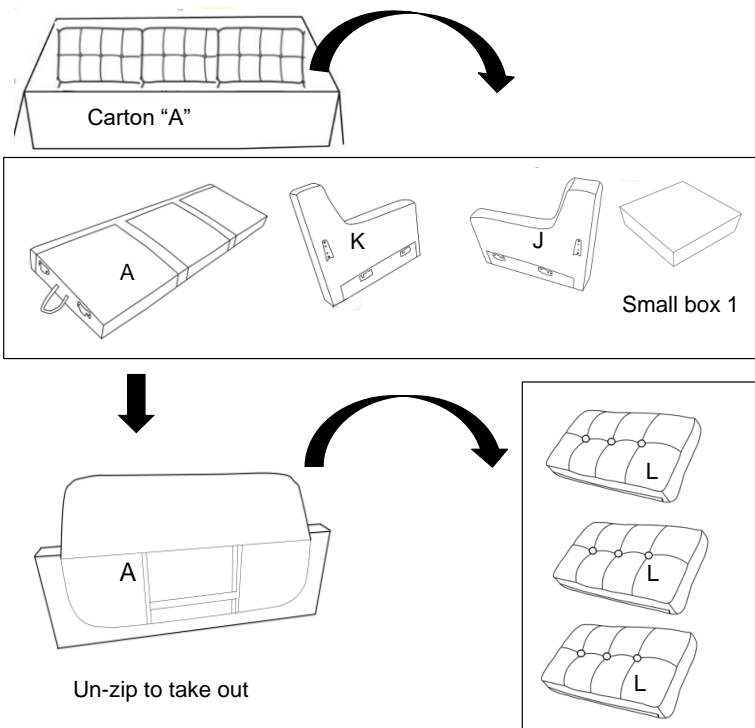

Open the Carton "A" to take out the Left Sofa Seat Base (A), Left Arm(J), Right Arm(K) and the small box 1 out, then un-zip the non-woven fabric under the Left Sofa Seat Base(A) to take out the three Sofa Back Cushions(L) and place them on a clean, non-marring surface.

Step 2

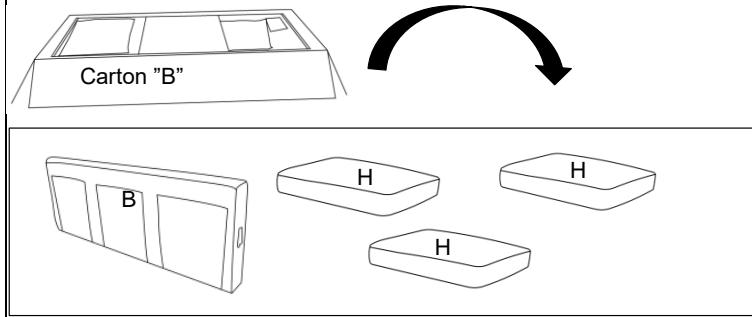

Open Carton "B" to take out the Left Sofa Backrest(B) and the three Sofa Seat Cushions(H) and place them on a clean, non-marring surface.

Step 3

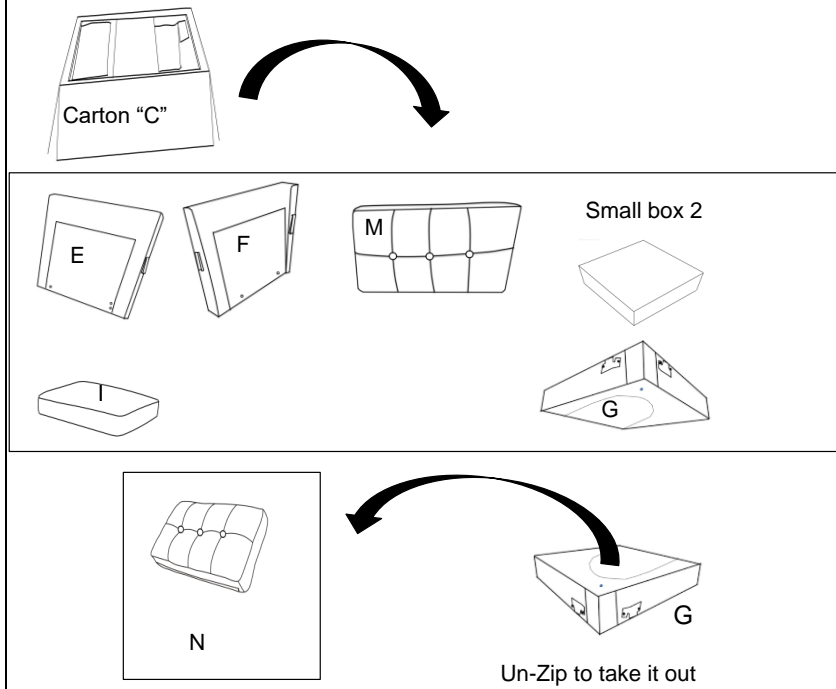

Open Carton "C" to take out the Corner Right Backrest(E), Corner Left Backrest (F), Corner Seat Base(G), Corner Seat Cushion(I), Corner Left Big Back Cushion(M) and the small box 2, then un-zip the non-woven fabric under the Corner Seat Base(G) to take out the Corner Right Small Back Cushion(N), place them on a clean, non-marring surface.

Step 4

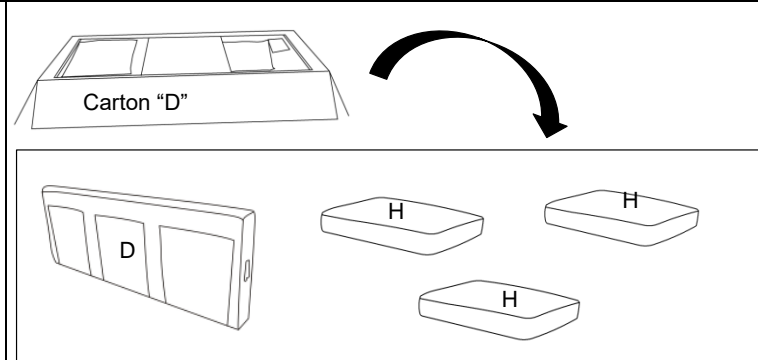

Open the Carton "D" to take out the Right Sofa Backrest(D) and the three Sofa Seat Cushions(H), and place them on a clean, non-marring surface.

Step 5

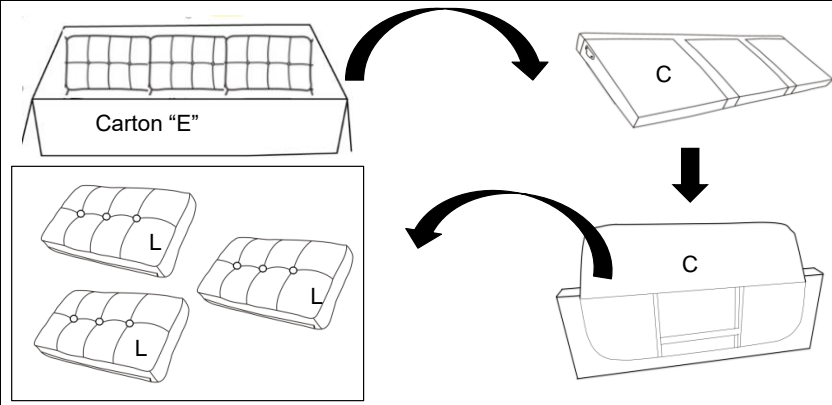

Open the Carton "E" to take out the Right Sofa Seat Base(C), then un-zip the non-woven fabric under Right Sofa Seat Base(C) to take out the three Sofa Back Cushions(L) and place them on a clean, non-marring surface.

Step 6

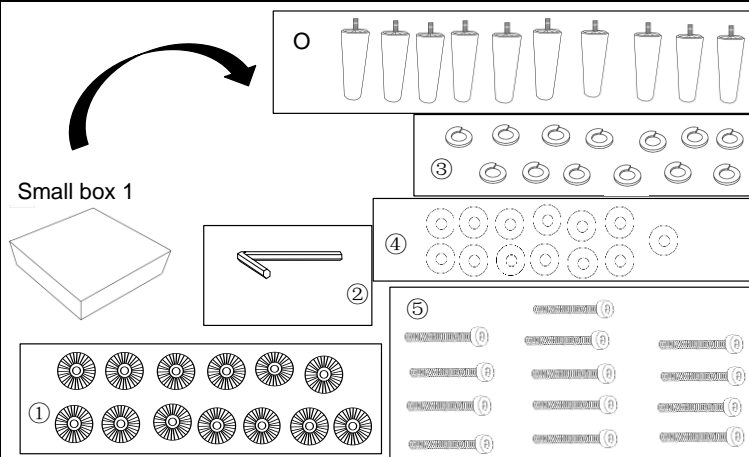

Open the Small Box 1 to take out the ten Wooden Legs(O) and Hardware.

Step 7

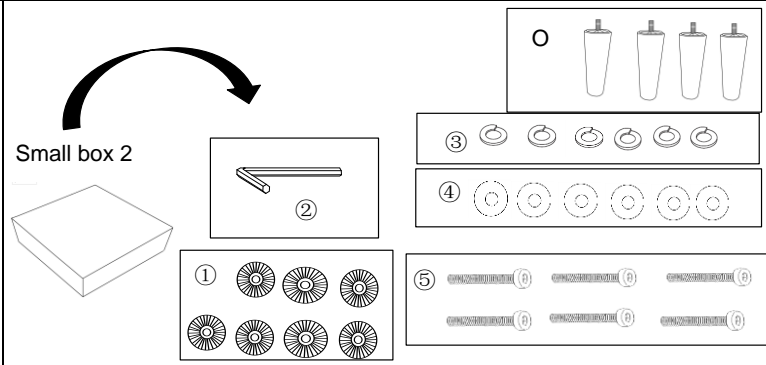

Open the Small Box 2 to take out the four Wooden Legs(O) and Hardware.

Step 8

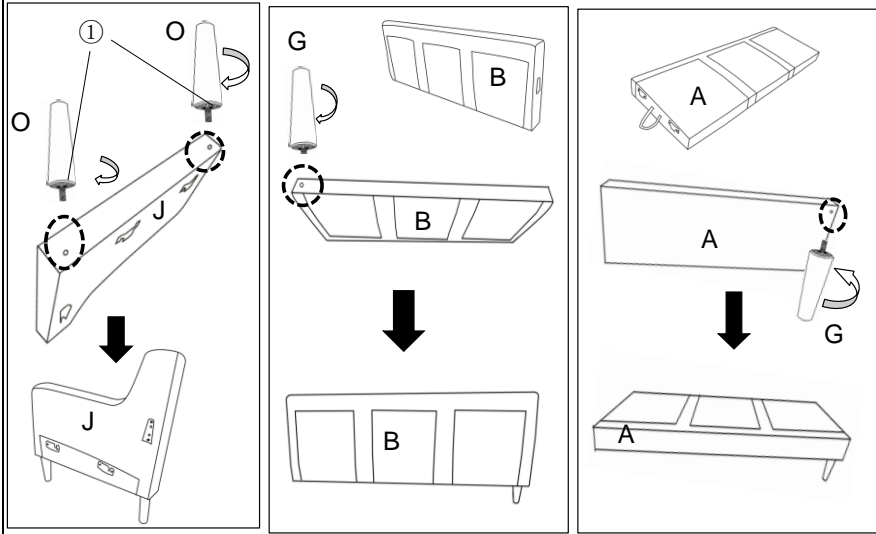

8.1 Carefully install the two Wooden Legs(O) at the bottom of the Left Arm(J).

8.2 Install one Wooden Leg(O) at the right side bottom of the Left Sofa Backrest(B).

8.3 And install one Wooden Leg(O) at the right front bottom of the Left Sofa Seat Base(A) as the pictured above.

Insert the threaded stem into the mounting position and tighten by turning clockwise.

Protect the shape of the Legs and ensure they are in the correct positions.

Note:The use of Plastic Gasket(①) are **OPTIONAL** and are especially useful to help alleviate slight wobbles. Some Legs may need more than one Plastic Gasket (①) while some legs may not need any.

Step 9

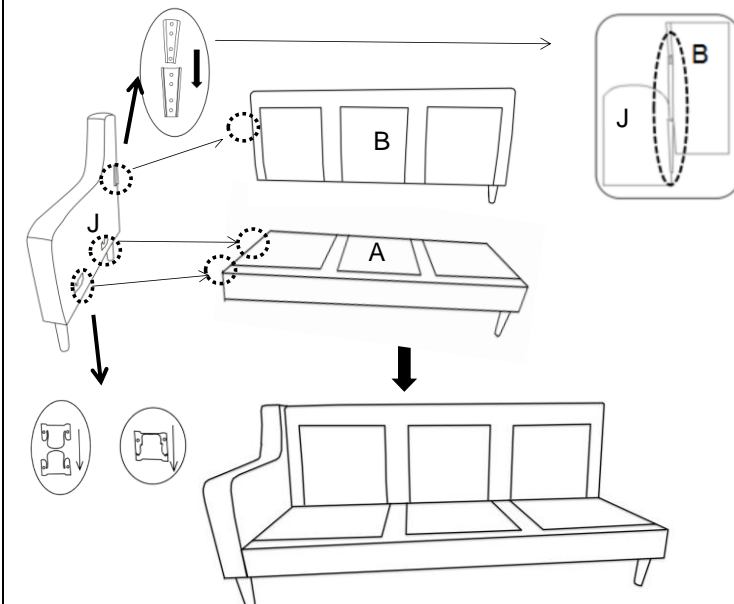

With the assistance from your adult partner:

9.1 Lift the Left Arm(J) up, make sure the Left Arm(J) is vertical and aligned to the Left Sofa Seat Base(A). Align the mounting brackets on the Left Arm(J) with those on the Left Sofa Seat Base(A).

9.2 Then align the mounting brackets on the left side of the Left Sofa Backrest(B) with those on the right top side of the Left Arm(J).

Your adult partner may need to push the Left Arm(J) inwards towards the Left Sofa Backrest(B) to allow for better alignment. Slip and Slide the Backrest in a gradual and balanced manner into the mounting brackets.

Note: Make sure the mounting brackets lock into the right positions .

Fully locked position: Check and assess that the Left Sofa Backrest(B) and the Left Sofa Seat Base(A) are aligned and level.

Step 10

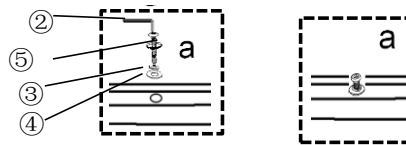
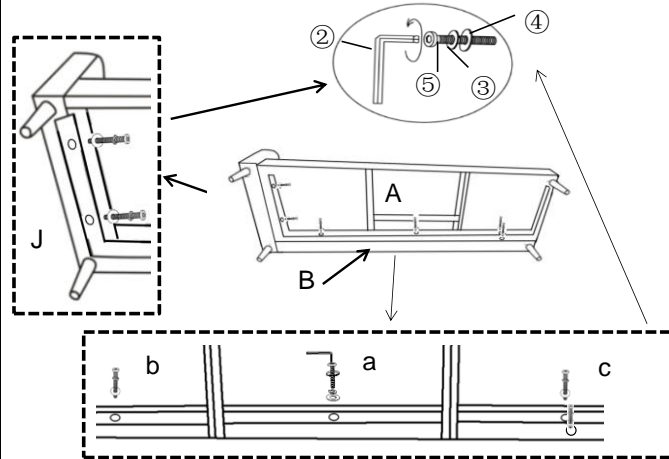

Insert the bolts(5) half-way starting at "a" then to "b" and "c". 

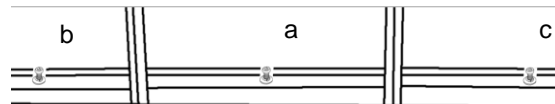

Then tighten the 7 Bolts with Allen Wrench(2)

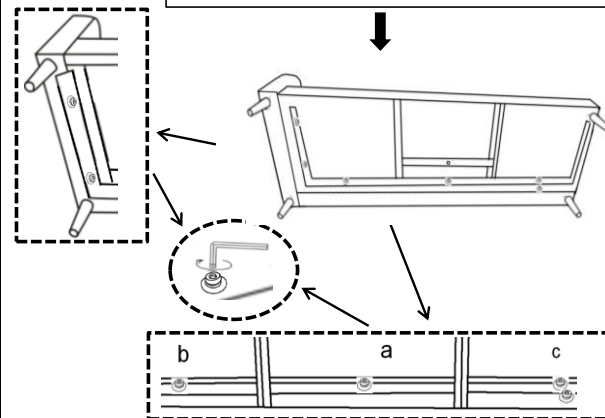

10.1 With assistance from your adult partner attach the Left Sofa Seat Base(A) to the Left Arm(J) & the Left Sofa Backrest(B) using the Bolts(Ⓞ), Spring Washers(Ⓝ)and Flat Gaskets(Ⓞ) with the Allen Wrench(Ⓜ).

10.2 Tighten the Bolts fully in a sequential manner.

DO NOT fully tighten a Bolt in one go and then move on to the next.

Rather, In a sequential Manner, Gradually tighten each Bolt little by little until all Bolts are evenly secured.

This methodology will ensure maximum evenness once all Bolts are fully tightened.

Make sure the bottoms of the Left Sofa Seat Base(A) and the Left Arm(J)& the Left Sofa Backrest(B) are level.

Assistance from an adult partner is needed for this assembly process.

Caution:Ensure that your fingers do not get caught or pinched in the assembly process.

Step 11

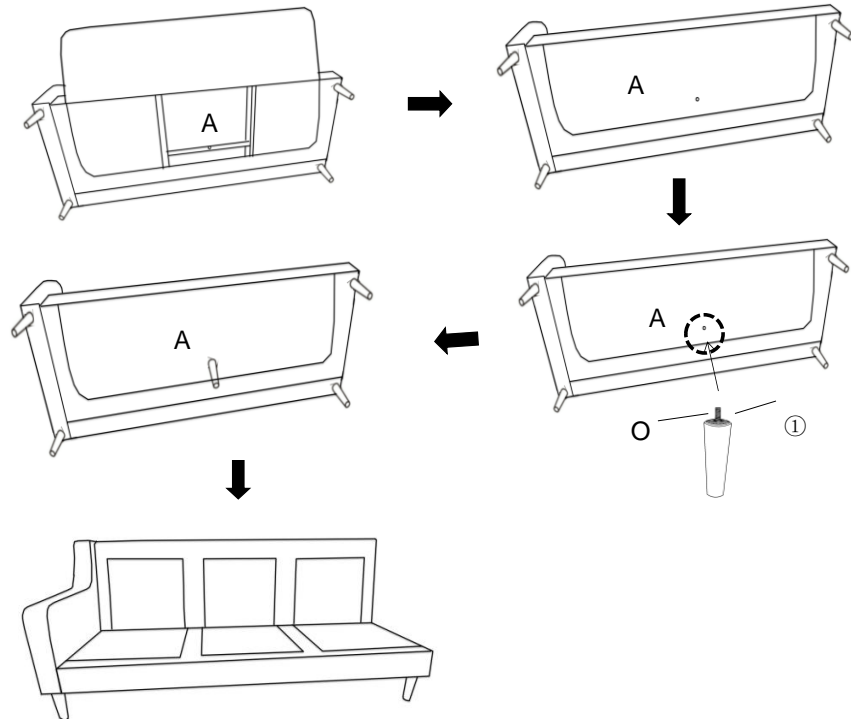

Un-Zip the non-woven fabric and you will see mounting position under the middle of the Left Sofa Seat Base(A). Carefully install the Wooden Leg(O) at the bottom of it.

Note:The use of Plastic Gasket(Ⓞ) are OPTIONAL and are especially useful to help alleviate slight wobbles. Some Legs may need more than one Plastic Gasket (Ⓞ) while some legs may not need any.

Step 12

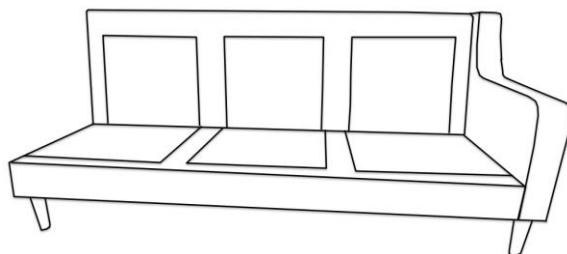

Do the same Steps(8 to12) as the Left Sofa Seat Base to assemble the Right Sofa Base as pictured above.

Now the Right Sofa Base is complete and ready for the other parts to be Assembled.

Step 13

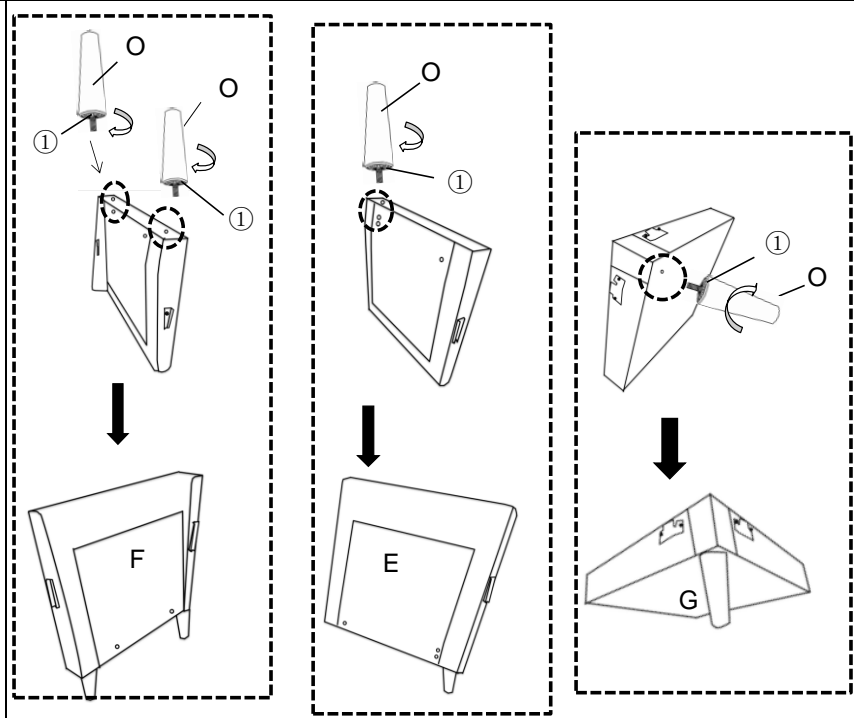

13.1 Carefully install the two Wooden Legs(O) at the bottom of the Corner Left Backrest (F).

13.2 Install one Wooden Leg(O) at the right side bottom of the Corner Right Backrest(E).

13.3 And install one Wooden Leg(O) at the front-Middle bottom of the Corner Seat Base(G) as pictured above.

Insert the threaded stem into the mounting position and tighten by turning clockwise.

Protect the shape of the Legs and ensure they are in the correct positions.

Note:The use of Plastic Gaskets(⓪) are **OPTIONAL** and are especially useful to help alleviate slight wobbles. Some Legs may need more than one Plastic Gasket (⓪) while some legs may not need any.

Step 14

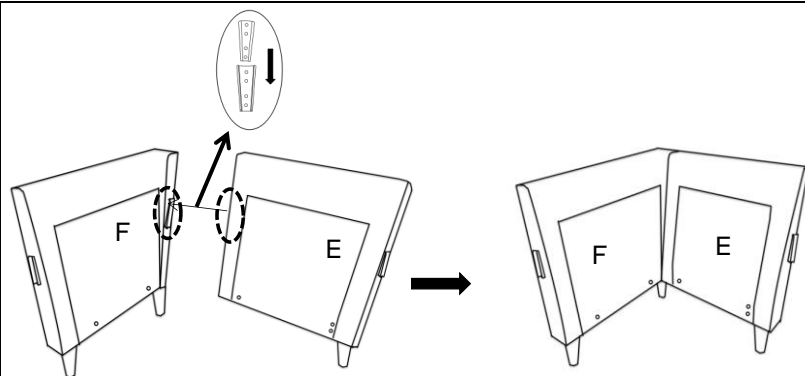

With assistance from your adult partner, align the mounting brackets on the Corner Right Backrest(E) with the one on the Corner Left Backrest(F), Then slide the Corner Right Backrest(E) downward to make sure it locks into place as pictured.

Step 15

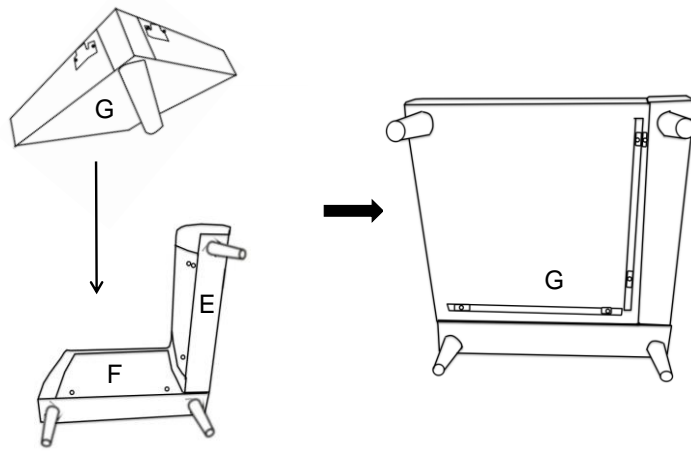

Place the Corner Seat Base(G) to the Front-bottom of the Corner Left Backrest(F) and the Corner Right Backrest(E) as pictured, align the mounting positions to the Corner Left Backrest(F) and the Corner Right Backrest(E).

Step 16

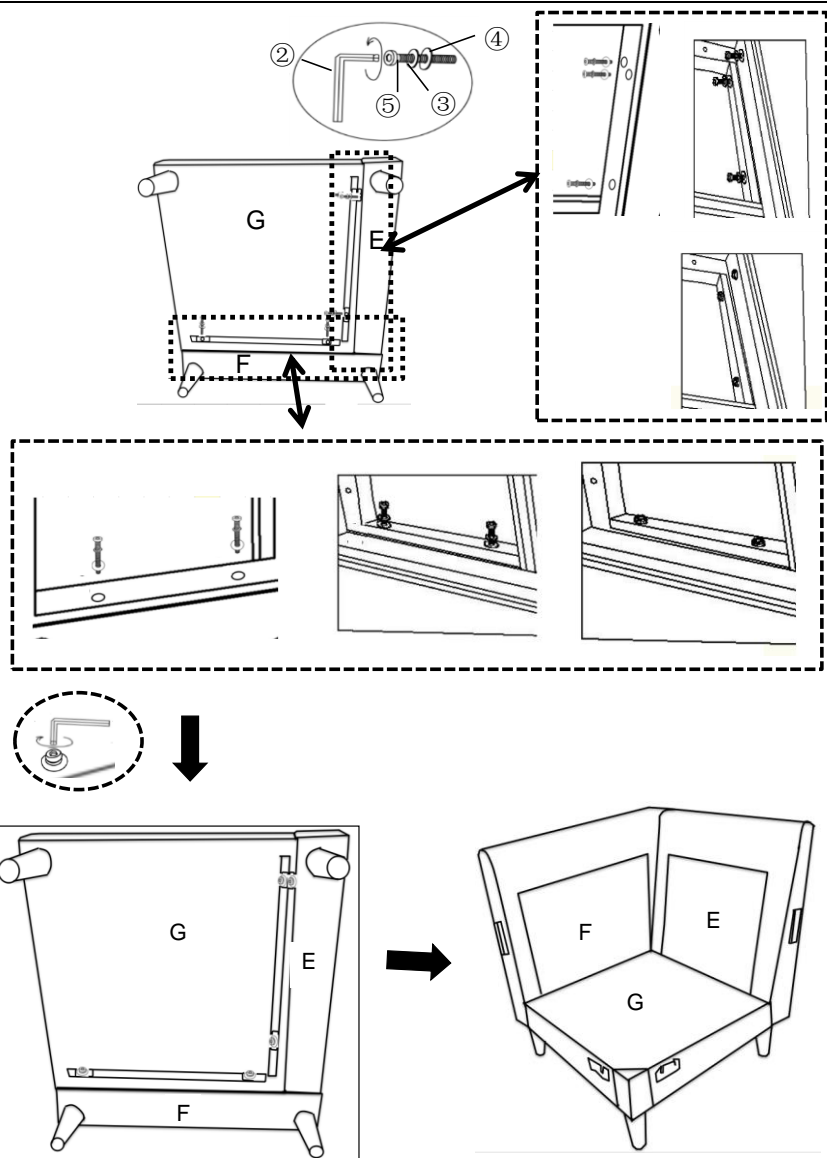

With the assistance from your partner, attach the Corner Seat Base(G) to the Corner Left Backrest(F) & Corner Right Backrest(E) using the Bolts(ⓐ), Spring Washers(ⓑ)and Flat Gaskets(ⓒ) with the Allen Wrench(ⓓ) as pictured above.

DO NOT fully tighten a Bolt in one go and then move on to the next.

Rather, In a sequential Manner, Gradually tighten each Bolt little by little until all Bolts are evenly secured.

This methodology will ensure maximum evenness once all Bolts are fully tightened.

Make sure the bottoms of the Corner Seat Base(G) and the Corner Left Backrest(F) & the Corner Right Backrest(E) are level.

Assistance from an adult partner is needed for this assembly process.

Caution:Ensure that your fingers do not get caught or pinched in the assembly process.

Step 17

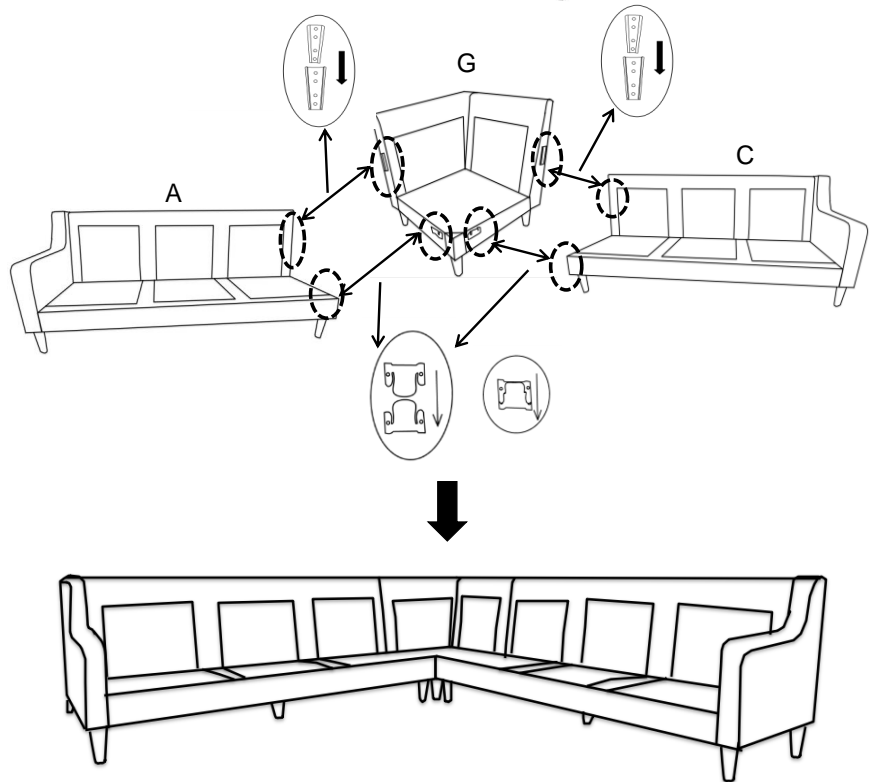

Connect the Left Sofa Seat Base(A), the Corner Seat Base(G) and the Right Sofa Seat Base(C) with the metal brackets as the pictures above.

Step 18

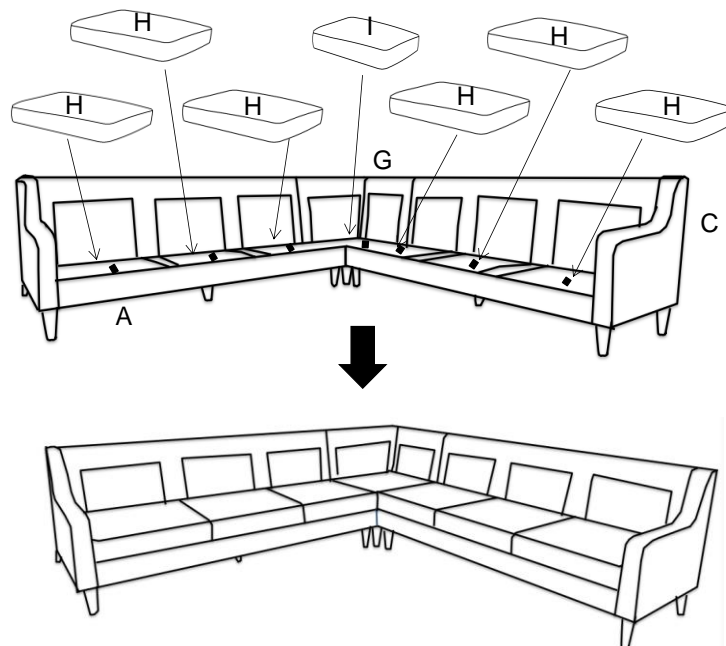

Place the Sofa Seat Cushions(H) on the Left Sofa Seat Base(A) and Right Sofa Seat Base(C) and place the Corner Seat Cushion(I) on the Corner Seat Base(G).
All the Seat Cushions need to be attached with Velcro.

Step 19

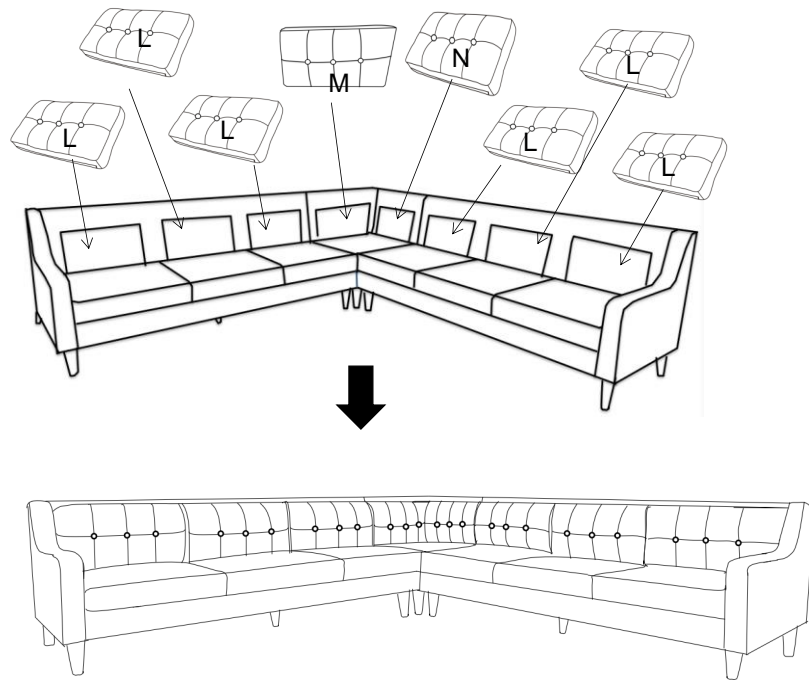

Place the Sofa Back Cushions(L) against the Left Sofa Backrest(B) and Right Sofa Backrest(D).
Then Place the Corner Left Big Back Cushion(M) against the Corner Left Backrest(F) and the
Corner Right Back Cushion(N), and the Corner Right Small Back Cushion(N) against the Corner
Right Backrest(E).

All the Back Cushions need to be attached with Velcro.

Please make sure all the parts are assembled to the right position and strongly connected.

Your Sectional Sofa is ready for use.

This Sectional Sofa can only be used on a flat, level surface.

Care & Maintenance

	<ul style="list-style-type: none">• Furniture may scratch floors. We recommend using furniture pads to protect your floors.
	<ul style="list-style-type: none">• Do not put hot items directly on furniture surface.
	<ul style="list-style-type: none">• Do not clean furniture with harsh cleansers or polish.
	<ul style="list-style-type: none">• Do not place furniture under direct sunlight.
	<ul style="list-style-type: none">• Do not place furniture near heating or cooling vents.
	<ul style="list-style-type: none">• Do not write on furniture without a padded barrier to protect the surface.
	<ul style="list-style-type: none">• Do not place furniture outside . For indoor use only.
	<ul style="list-style-type: none">• Not for commercial use. For residential use only.
	<ul style="list-style-type: none">• Stains may be removed with mild soap solution and damp cloth.
	<ul style="list-style-type: none">• Children should not climb or jump on the furniture.
	<ul style="list-style-type: none">• Dust and pick-up spills using a clean, non-colored, lint-free cloth.