

Assembly Instructions

Caution : You should read this carefully before you proceed

Please look in the third support leg for hardware packs

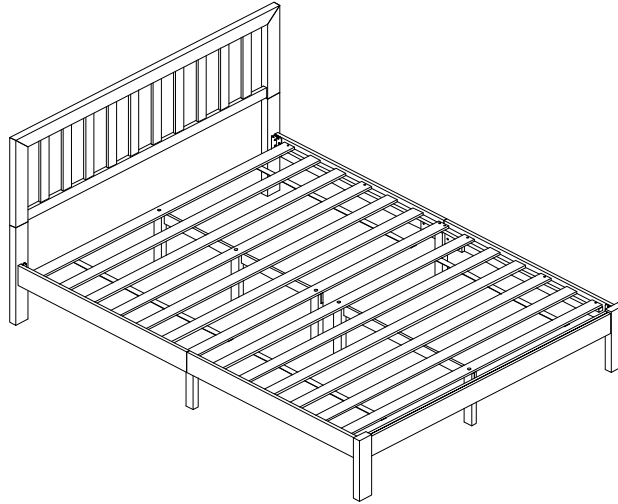



Bed

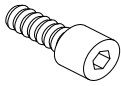
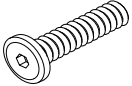
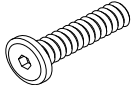

Parts List

| Label | Picture | Description | QTY |
|-------|---------|--------------------|-----|
| A | | Headboard | 1 |
| B | | Right Leg | 1 |
| C | | Left Leg | 1 |
| D | | Footboard | 1 |
| E | | First Side Rail | 2 |
| F | | Second Side Rail | 2 |
| G | | First Support Leg | 1 |
| H | | Second Support Leg | 1 |
| I | | Third Support Leg | 2 |
| J | | First Slat Frame | 1 |
| K | | Second Slat Frame | 1 |

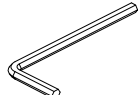
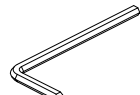
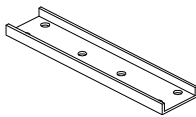
Hardware

| Label | Picture | Description | QTY |
|-------|---|----------------------------|-----|
| ① |  | Bolt (M6 x 10 mm) | 9 |
| ② |  | Bolt (M8 x 25 mm) | 13 |
| ③ |  | Bolt (M6 x 25 mm) | 18 |
| ④ |  | Screw (ϕ 4 x 25 mm) | 15 |
| ⑤ |  | Allen Key (K5) | 2 |
| ⑥ |  | Allen Key (K4) | 2 |
| ⑦ |  | Connection Metal | 2 |
| ⑧ |  | Screwdriver (not provided) | 1 |

Assembly Preparation

Before Beginning Assembly:

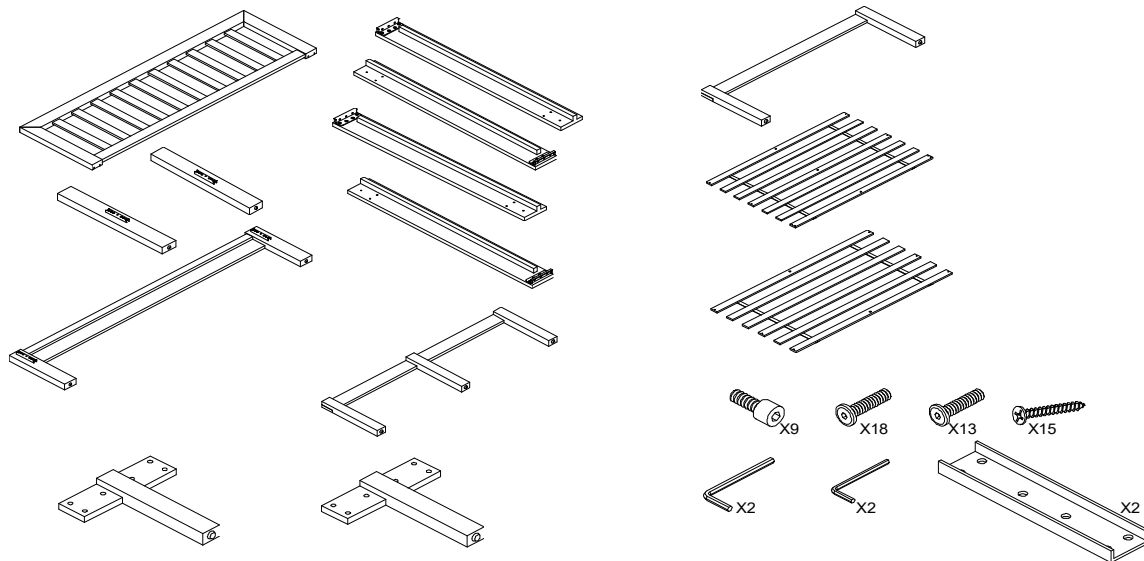

- Read instructions, cover to cover-



- Have 2 adults on hand for assembly-



- Do not assemble on flooring or carpet-



- Assemble on a clean non-marring surface (packing foam)-



- Save all packaging until finished-

Assembly Steps

OVERVIEW

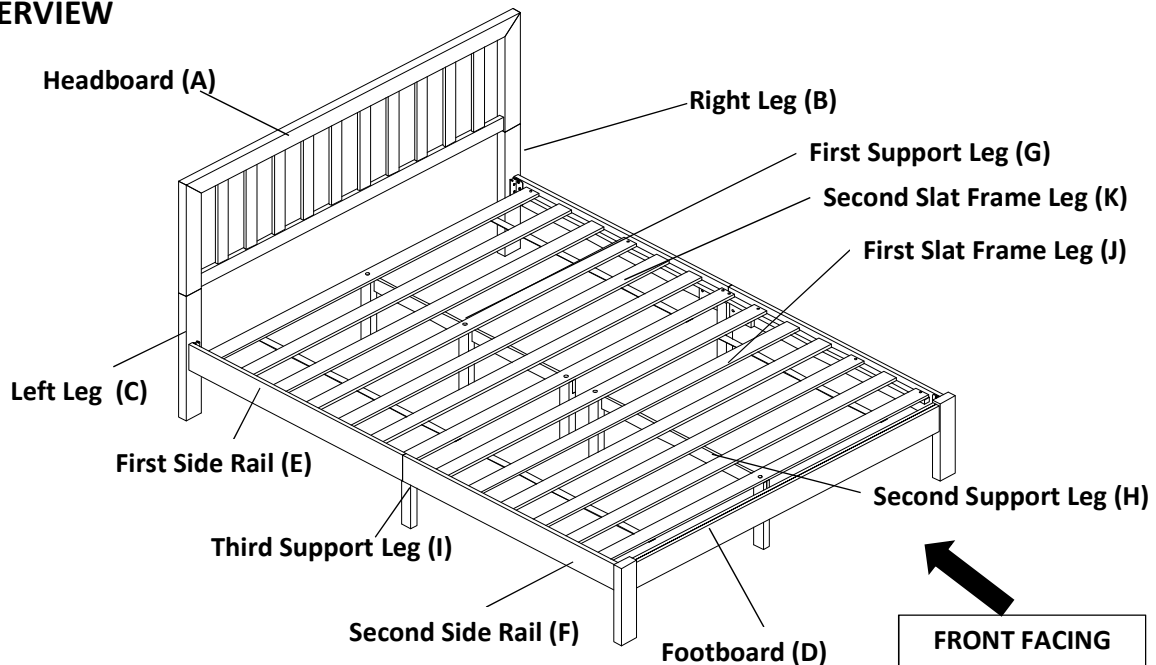

This Bed has multiple parts and may require up to some 30 minutes to assemble. To give you an overview of the Bed parts, the above picture is provided to help you put the various parts into perspective. Please read through the instructions below to familiarise yourself with the parts and steps before assembly.

Step 1:

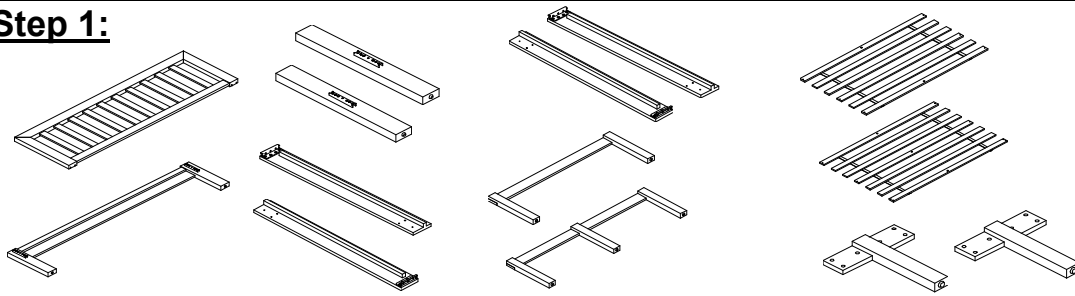

Unpack and place all parts on a clean, non-marring surface.

Step 2:

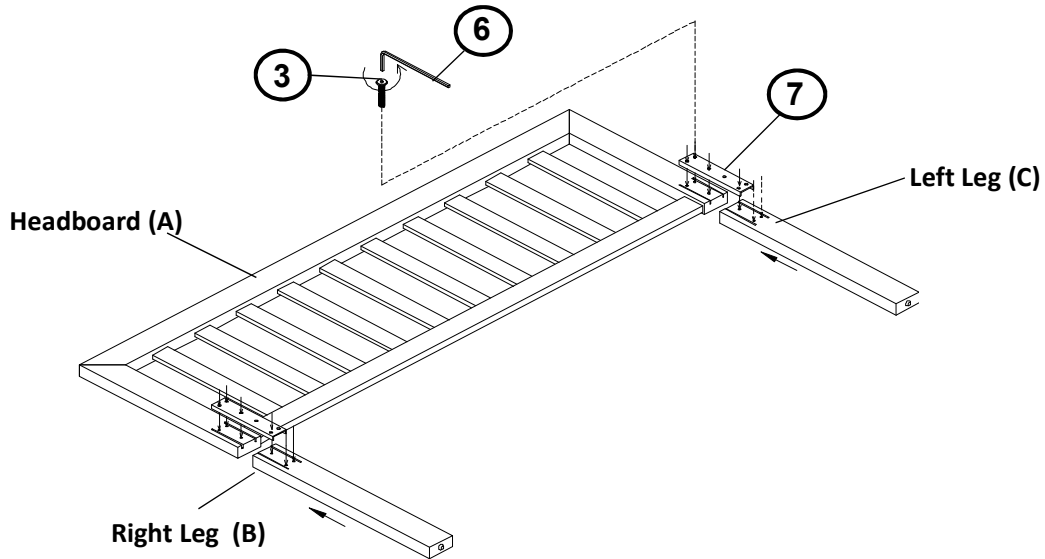

With assistance from your adult partner, carefully place the Headboard(A) facedown on a clean, non-marring surface as shown above.

Attach the Right Leg (B) and the Left Leg (C) to the Headboard (A), then place the Connection Metal (7) onto it as shown above. Secure it using Bolts (3) and the Allen Key (6).

Do not fully tighten the Bolts at this stage.

Step 3:

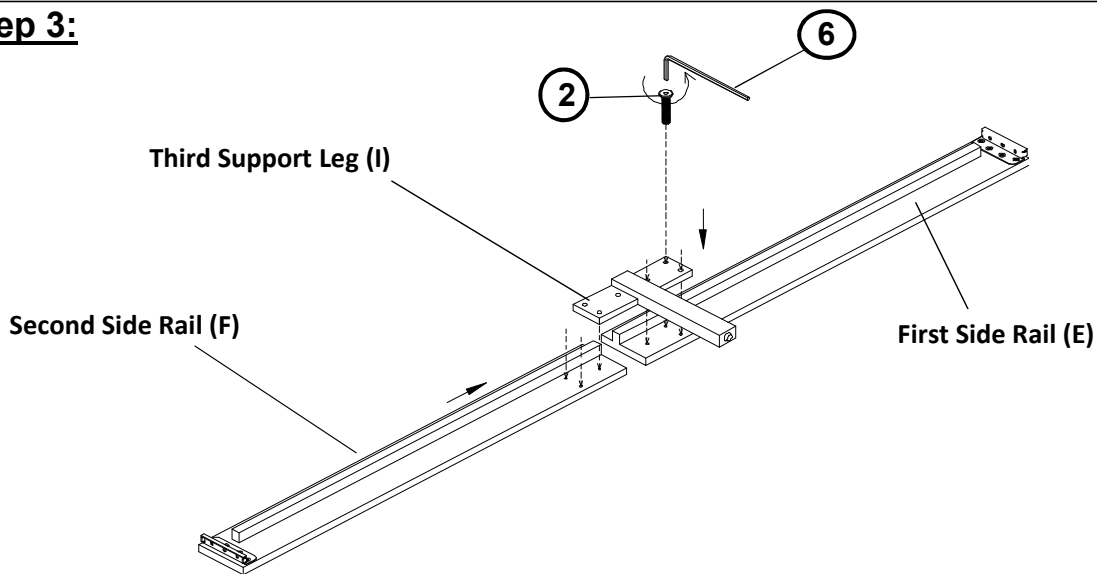

Connect the Third Support Leg (I) to the First Side Rail (E) and the Second Side Rail (F), then secure it using Bolts (2) and the Allen Key (6) as shown above.

Repeat the same process with the remaining First Side Rail (E) and the Second Side Rail (F).

Do not fully tighten the Bolts at this stage.

Step 4:

Headboard (A)

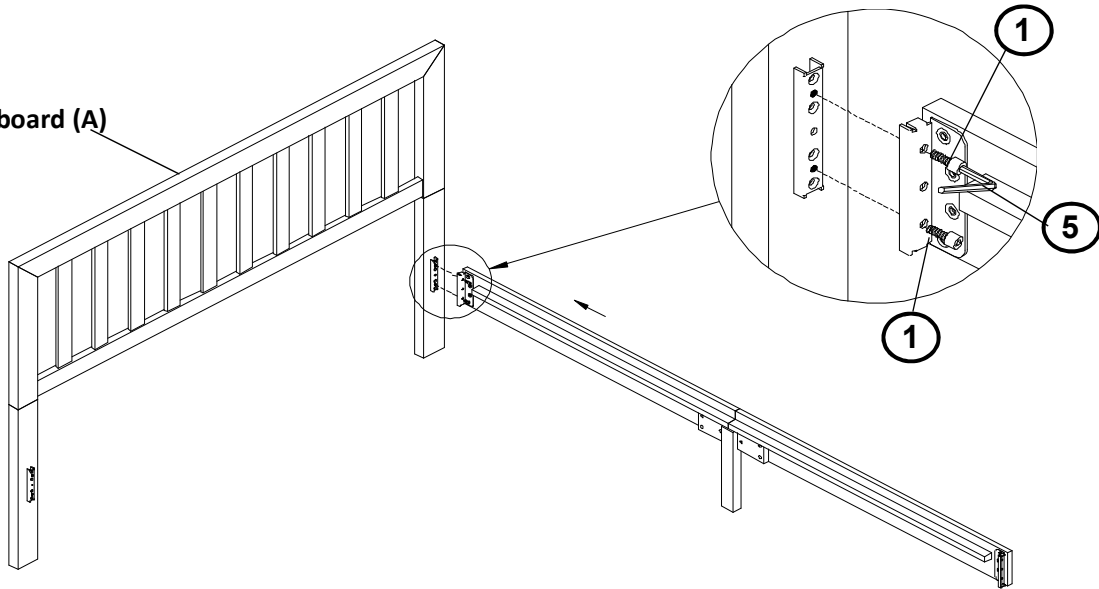

With the help of your adult partner, attach the frame from step 3 to the frame from step 2, then secure it using Bolts (1) and the Allen Key (5) as shown above.

Do not fully tighten the Bolts at this stage.

Step 5:

Headboard (A)

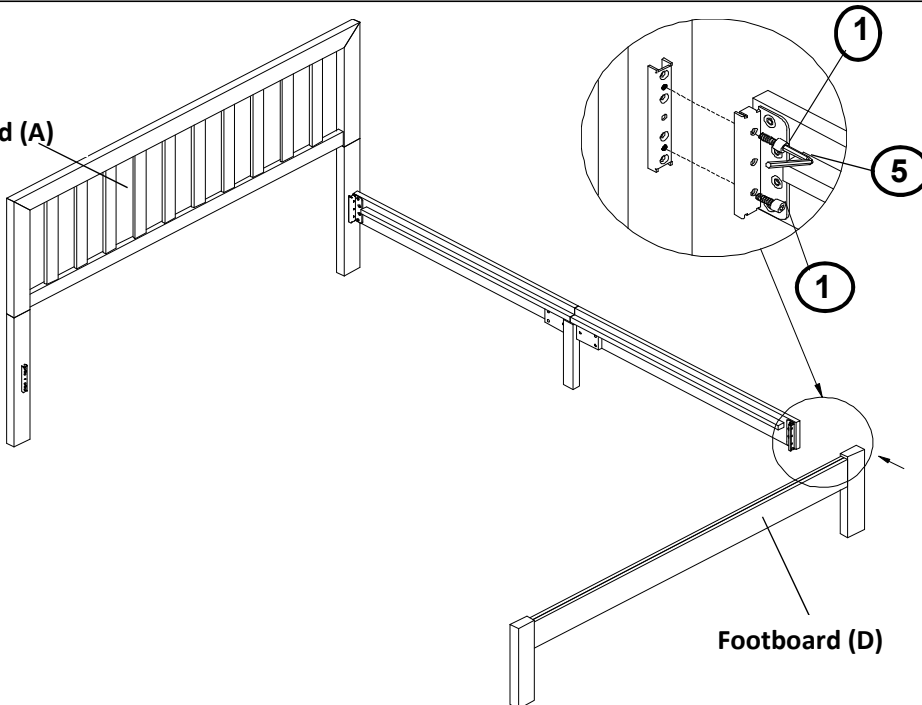

Footboard (D)

With the help of your adult partner, attach the Footboard (D) to the frame from step 4, then secure it using Bolts (1) and the Allen Key (5) as shown above.

Do not fully tighten the Bolts at this stage.

Step 6:

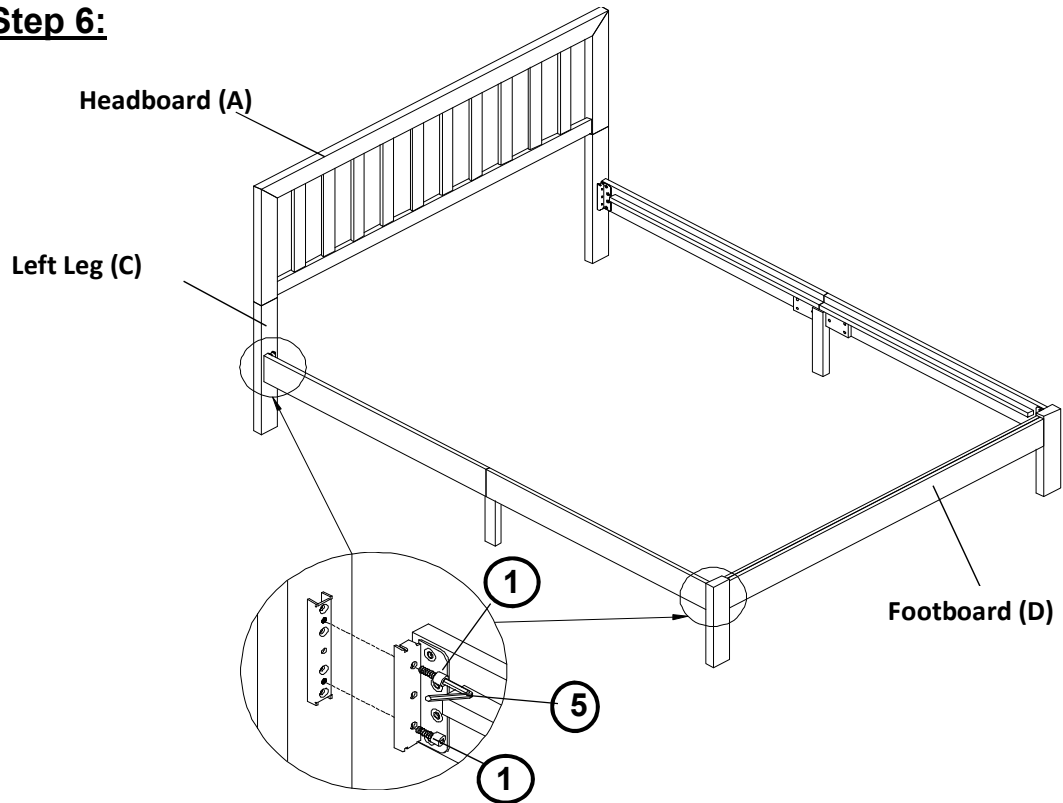

With the help of your adult partner, align the Left Leg (C) to the frame from step 3 and the Footboard (D). Secure it using Bolts (①) and the Allen Key (⑤) as shown above.

Do not fully tighten the Bolts at this stage.

Step 7:

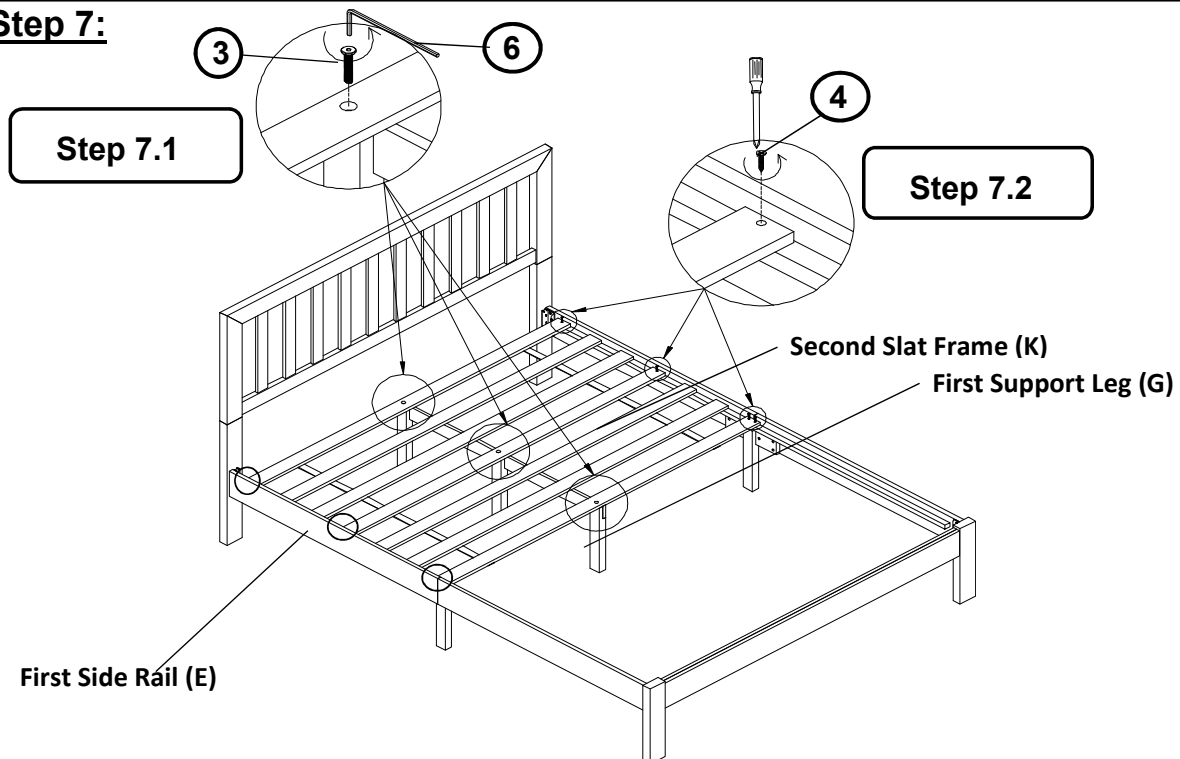

7.1 Secure the Second Slat Frame (K) to the First Support Leg (G) using Bolts (③) and the the Allen Key (⑥) as shown above.

7.2 Secure the Second Slat Frame (K) to the First Side Rail (E) using Screws (④) and a Screwdriver (not provided) as shown above.

Do not fully tighten the Bolts and screws at this stage.

Step 8:

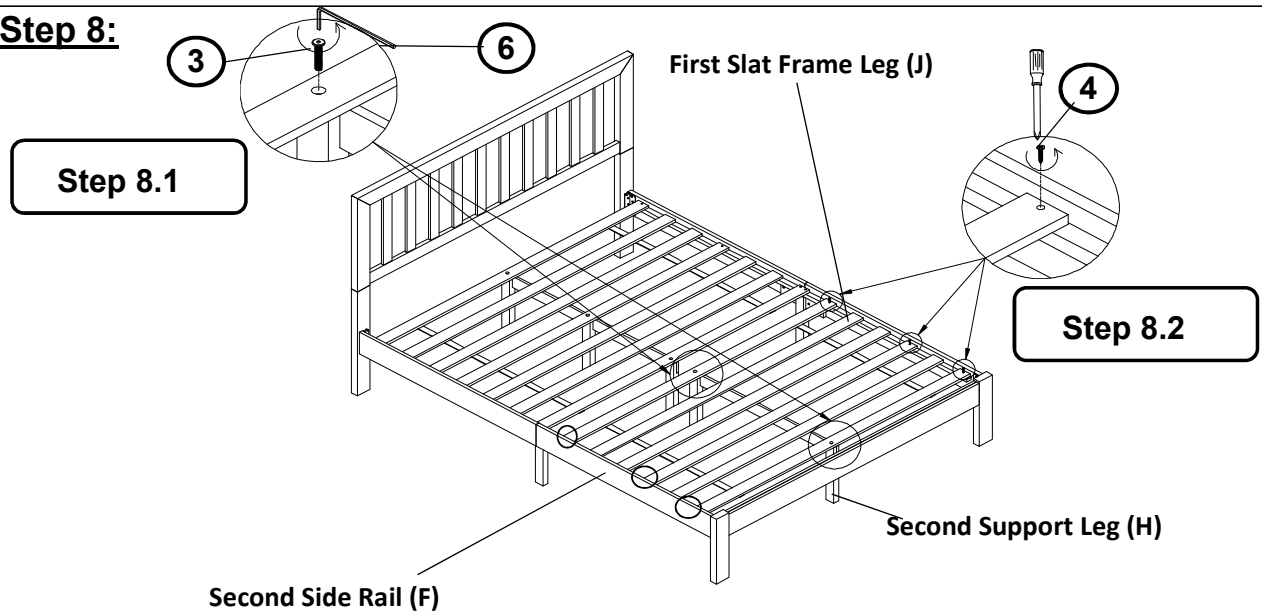

8.1 Secure the First Slat Frame (J) to the Second Support Leg (H) using Bolts (③) and the Allen Key (⑥) as shown above.

8.2 Secure the First Slat Frame (J) to the Second Side Rail (F) using Screws (④) and a Screwdriver (not provided) as shown above.

Do not fully tighten the Bolts and screws at this stage.

Step 9:

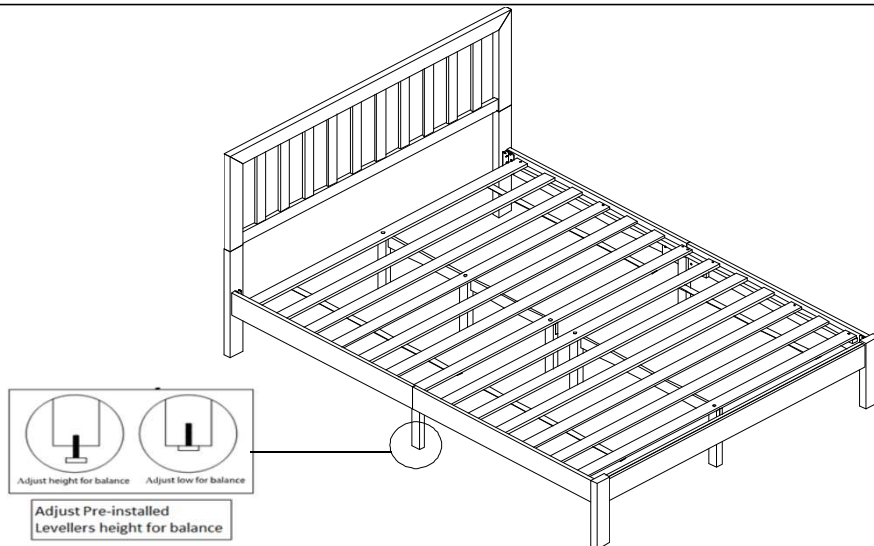

Check for wobbles.

If the bed does not wobble, in a sequential manner, gradually tighten all Bolts until evenly secured.

Inspect the Bed and make sure all parts are adequately connected.



















With assistance from your adult partner, adjust the levellers to the desired height to avoid wobbles.

To adjust the Levellers, get assistance from an adult partner to lift/lean and hold the Bed while you are working.

Your Bed is ready for use.

This Bed can only be used on a flat, level surface.

Care & Maintenance

-   ● Do not put hot items directly on furniture surface
 -   ● Do not clean furniture with harsh cleansers or polish.
 -   ● Do not place furniture under direct sunlight.
 -   ● Do not place furniture near heating or cooling vents.
 -   ● Do not write on furniture without a padded barrier to protect the surface.
 -   ● Do not place furniture outside . For indoor use only .
 -   ● Not for commercial use. For residential use only .
 -   ● Stains may be removed with mild soap solution and damp cloth.
 -   ● Children should not climb or jump on the furniture.
-
-   ● Dust and pick-up spills using a clean, non-colored, lint-free cloth .