

ASSEMBLY INSTRUCTION

NO	PARTLIST	QTY
1	HEADBOARD WITH LABEL "1"	2PCS
2	HEADBOARD WITH LABEL "2"	1PC
3	HEADBOARD LEG	2PCS
4	FOOTBOARD	1PC
5	FOOTBOARD LEG	2PCS
6	SIDE RAIL	2PCS
7	ROLL SLAT	2SETS
8	HEADBOARD SUPPORT (SHORT)	1PC
ITEM	HARDWARE	QTY
A	JCBB SCREW M8 x 20MM	8PCS
B	JCBB SCREW M8 x 35MM	9PCS
C	JCBC SCREW M6 x 100MM	2PCS
D	WOOD DOWEL M8 x 30MM	2PCS
E	SPRING WASHER M8 x 14MM	9PCS
F	FLAT WASHER M8 x 22MM	9PCS
G	SCREW M4 x 32MM	8PCS
H	PANHEAD SCREW M4 x 25MM	6PCS
I	L-KEY M5 x 65MM	1PC
J	L-KEY M4 x 100MM	1PC

STEP 1

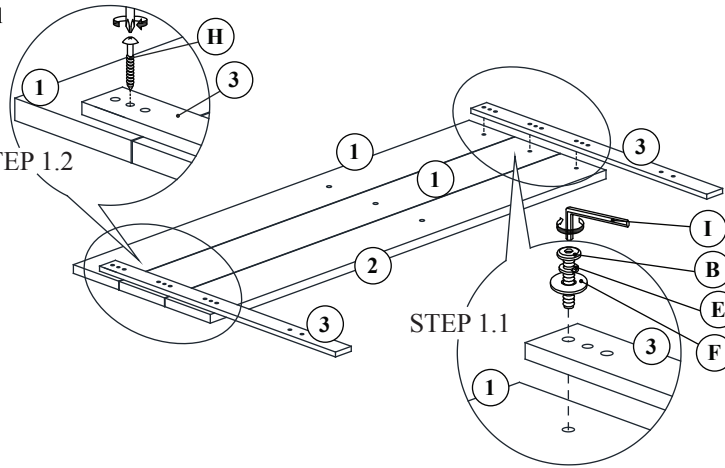

STEP 2

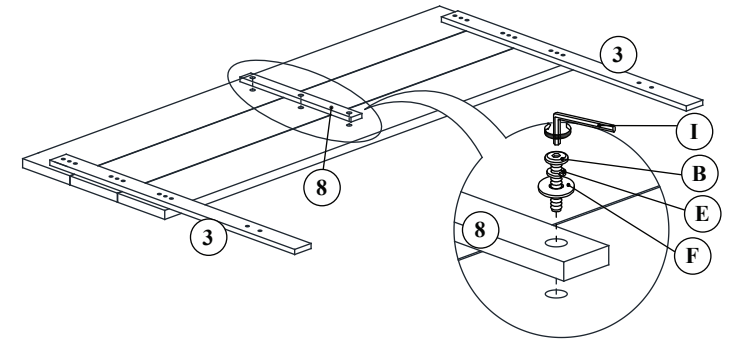

STEP 3

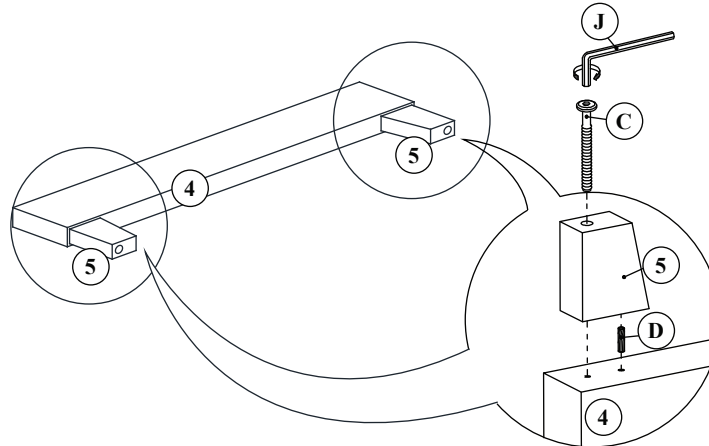

STEP 4

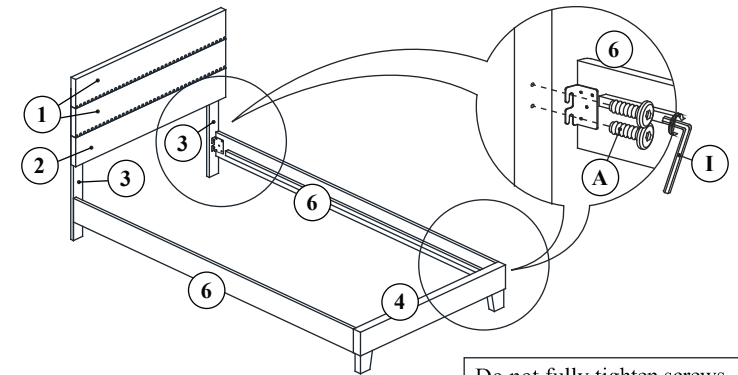

Do not fully tighten screws until assembly is complete and the bed is level.

STEP 5

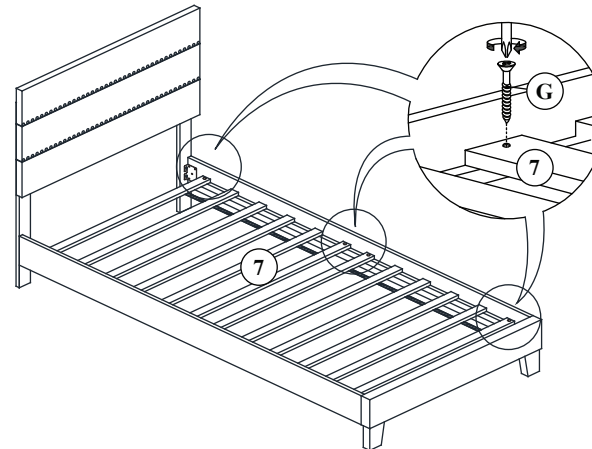

ASSEMBLY COMPLETED