

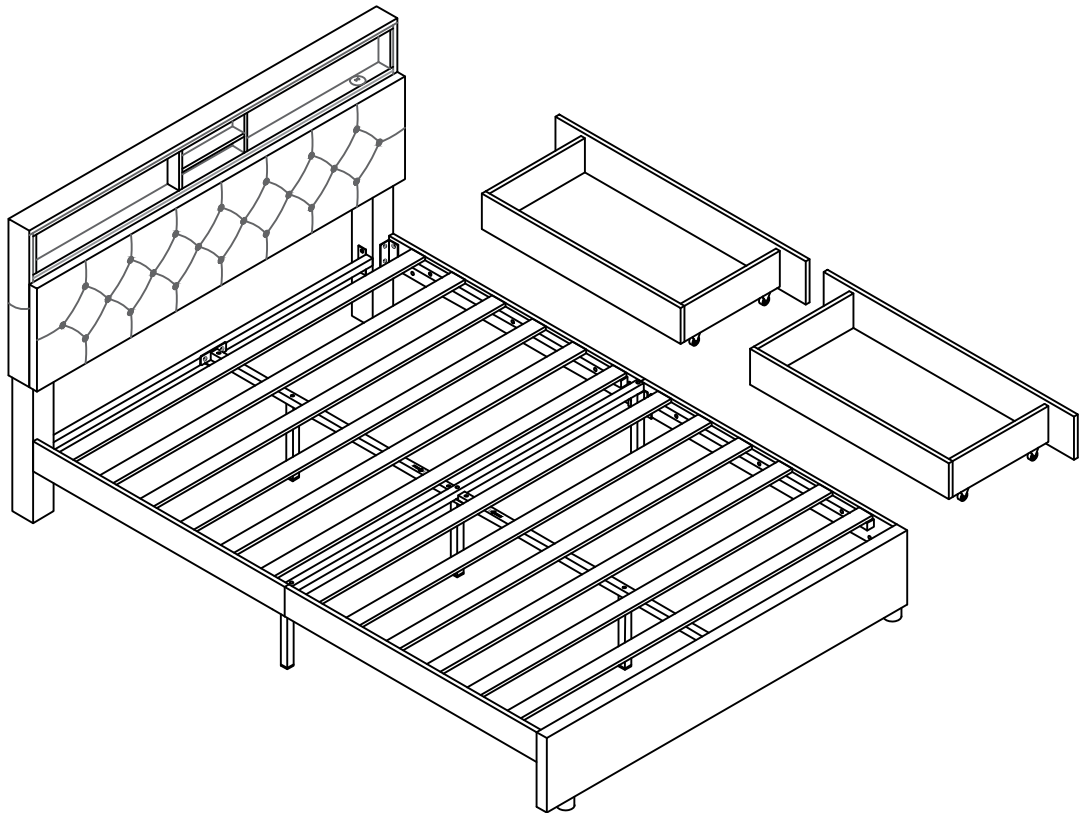

ASSEMBLY INSTRUCTION

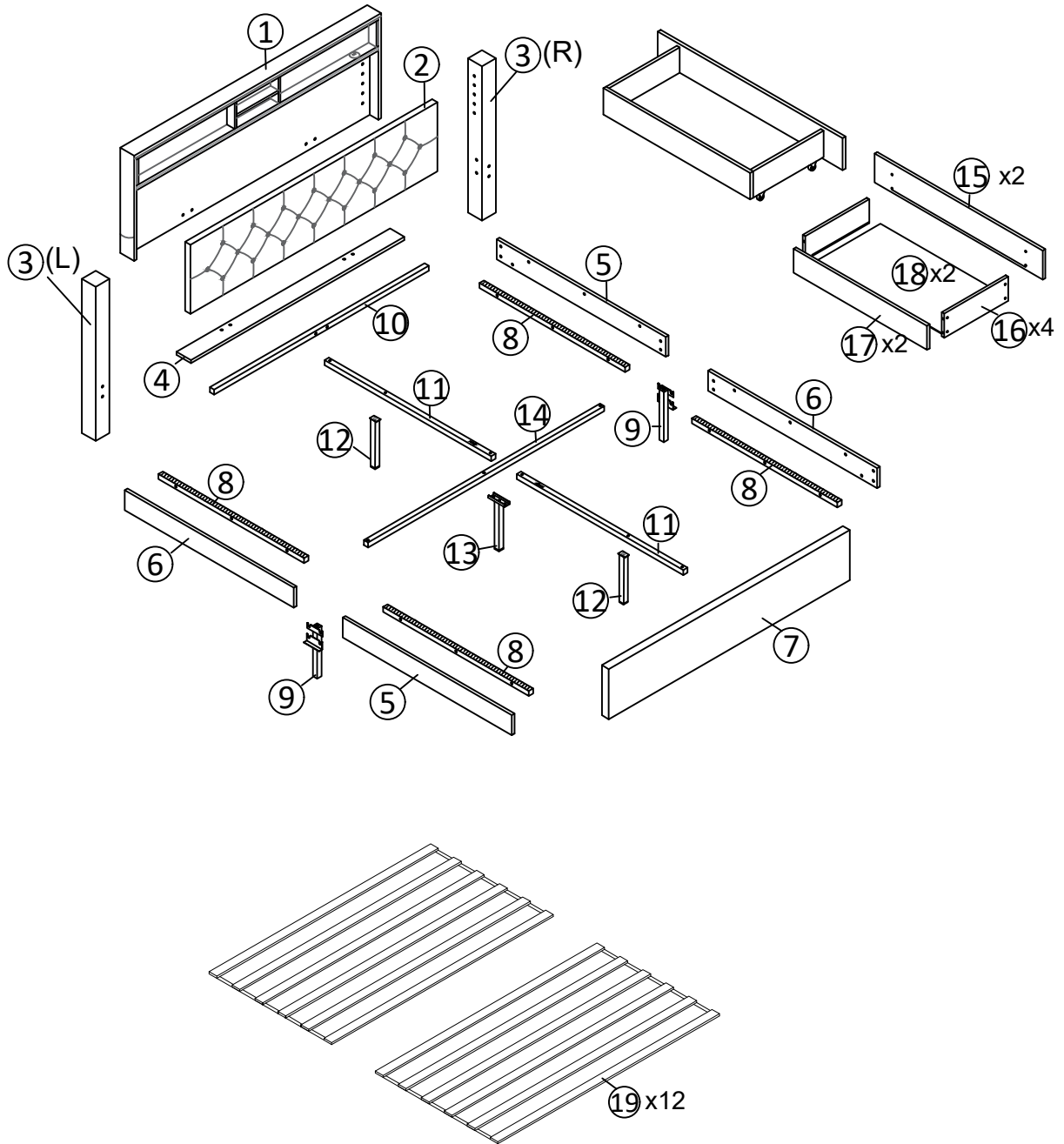





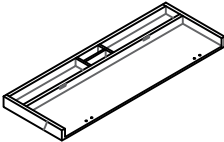

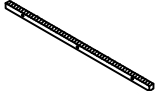
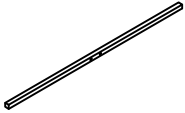
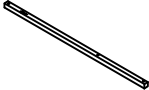
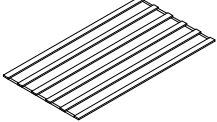
Detail View



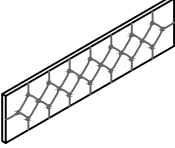
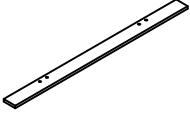
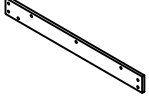
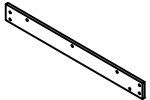
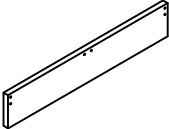



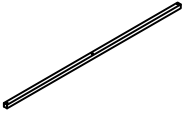

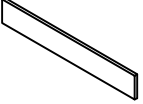
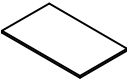





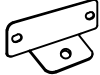

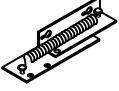
Part List

<p>1</p>  <p>Head board-1pc</p>	<p>3</p>  <p>Head board legs-2pcs</p>	<p>8</p>  <p>Side rails support bar-4pcs</p>
<p>10</p>  <p>Head board cross bar-1pc</p>	<p>11</p>  <p>Center support bar-2pcs</p>	<p>19</p>  <p>Slats-12pcs</p>

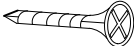
WF303736AAA / WF303736AAE
 WF303739AAA / WF303739AAE

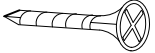
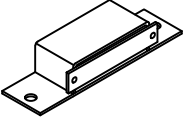

<p>2</p>  <p>Surface board-1pc</p>	<p>4</p>  <p>Bottom board-1pc</p>	<p>5</p>  <p>Siderails-2pcs</p>
<p>6</p>  <p>Siderails-2pcs</p>	<p>7</p>  <p>Foot board-1pc</p>	<p>9</p>  <p>Side rails support legs-2pcs</p>
<p>12</p>  <p>Middle support leg-2pcs</p>	<p>13</p>  <p>Connected support leg-1pc</p>	<p>14</p>  <p>Cross bar-1pc</p>
<p>15</p>  <p>Drawer outer board-2pcs</p>	<p>16</p>  <p>Drawer board-4pcs</p>	<p>17</p>  <p>Drawer board-2pcs</p>
<p>18</p>  <p>Drawer bottom board-2pcs</p>		

Hardware List

A  20*70mm	B  Ø8*40mm	C  28*32*86*2mm
Allen Key(2pcs) Bolts(27pcs) Center support bar fittings(4pcs)		
D  Ø8*18mm	E  77*33**33*3mm	F  148*42*32mm
Bolts(42pcs) "7" Connector(6pcs) Hinge(2pcs)		
G  Ø4*50mm	H  H:30mm	I 
Nails(2pcs) Bed legs(2pcs) Drawer fittings(16pcs)		
J 	K  Ø3*20mm	L 
Drawer fittings(16pcs) Nails(16pcs) Wheel(8pcs)		
M  50*25*2mm	N  Ø6*15mm	O 
Stopper(2pcs) Bolts(8pcs) Connecting line(1pc)		
P 	Q 	R  Ø3*16mm
Power adapter(1pc) Color controller(1pc) Nails(8pcs)		
S  Roller latch(2pcs)		

Remark: We recommend you assemble your bed in the flat ground.



Step 1 x2

A		B	 M8X40mm
		4PCS	

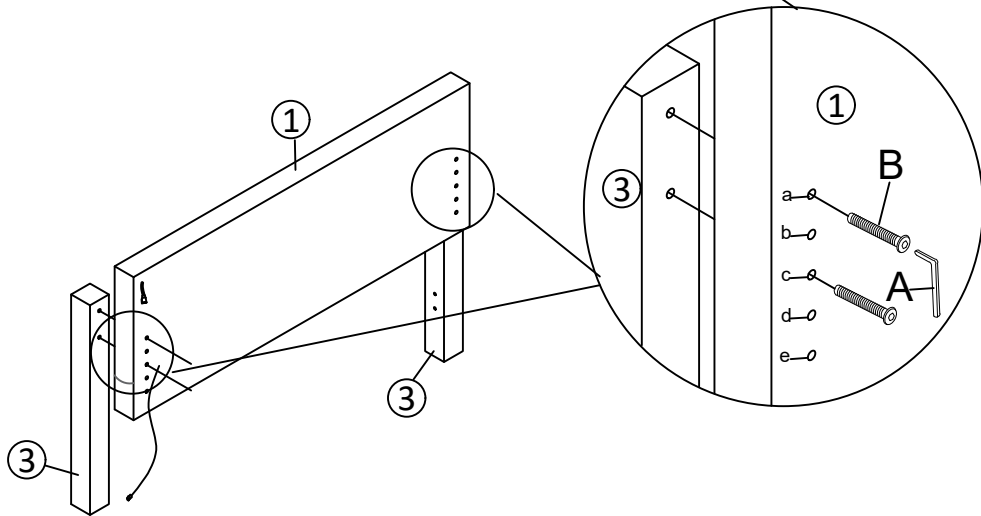
Attention:
You can chose the hole a
and c ,or b and d,or c and e.



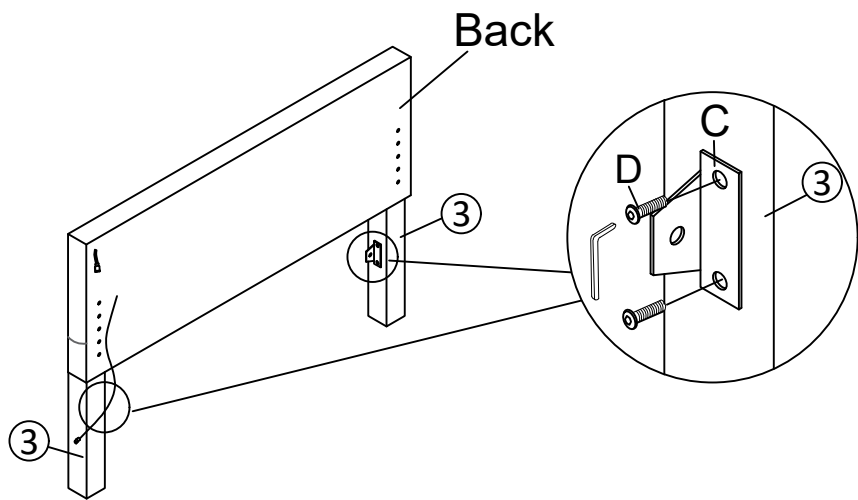

Step 2 x2

A		C		D	 M8X18mm
		2PCS		4PCS	



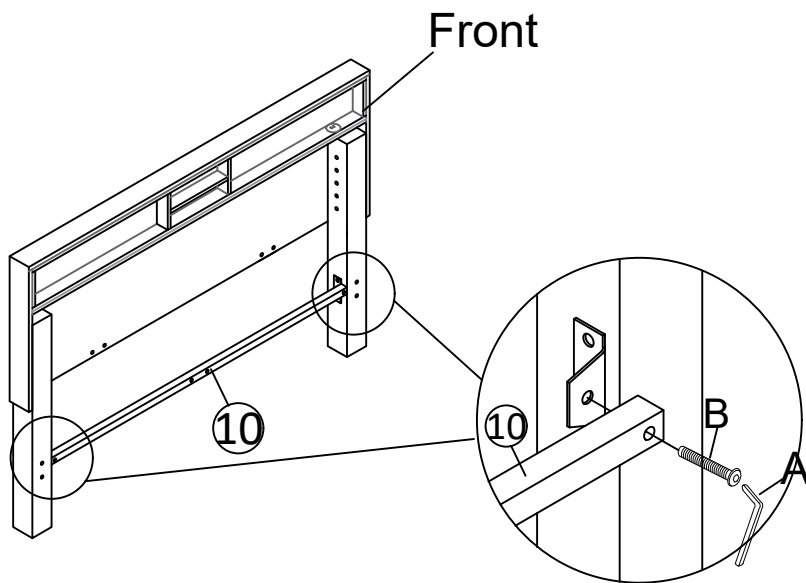

Step 3

<p>A</p> 	<p>B</p>  <p>M8X40mm</p> <p>2PCS</p>
---	--



Step 4

<p>A</p> 	<p>D</p>  <p>M8X18mm</p> <p>8PCS</p>	<p>E</p>  <p>2PCS</p>
--	--	---

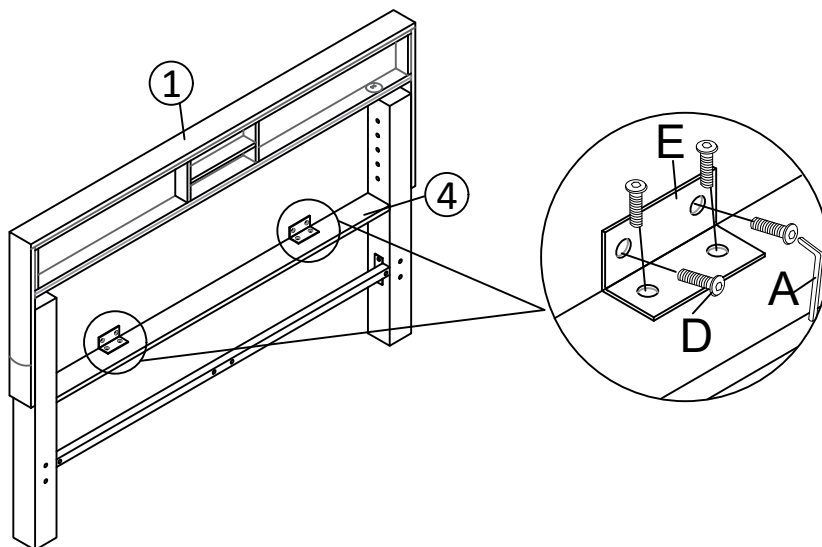

Step 5

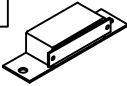
R	S
 M3X16mm	
8PCS	2PCS

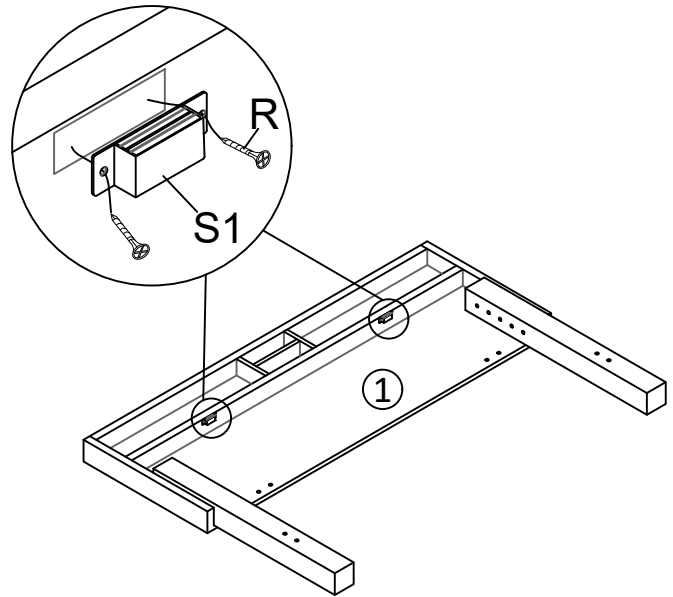
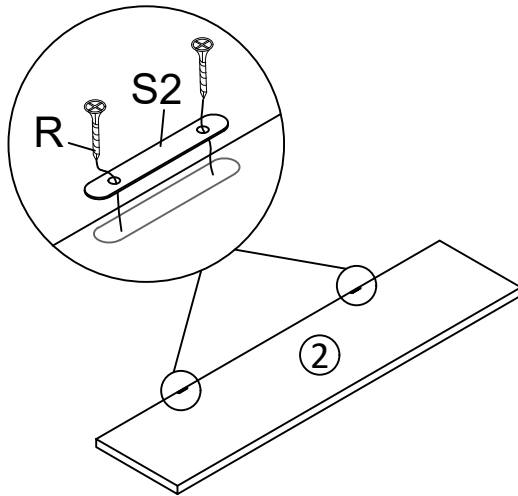
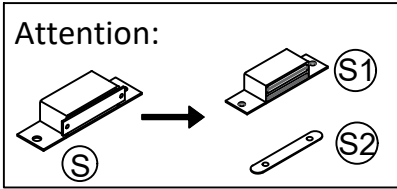

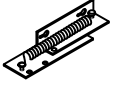

Step 6

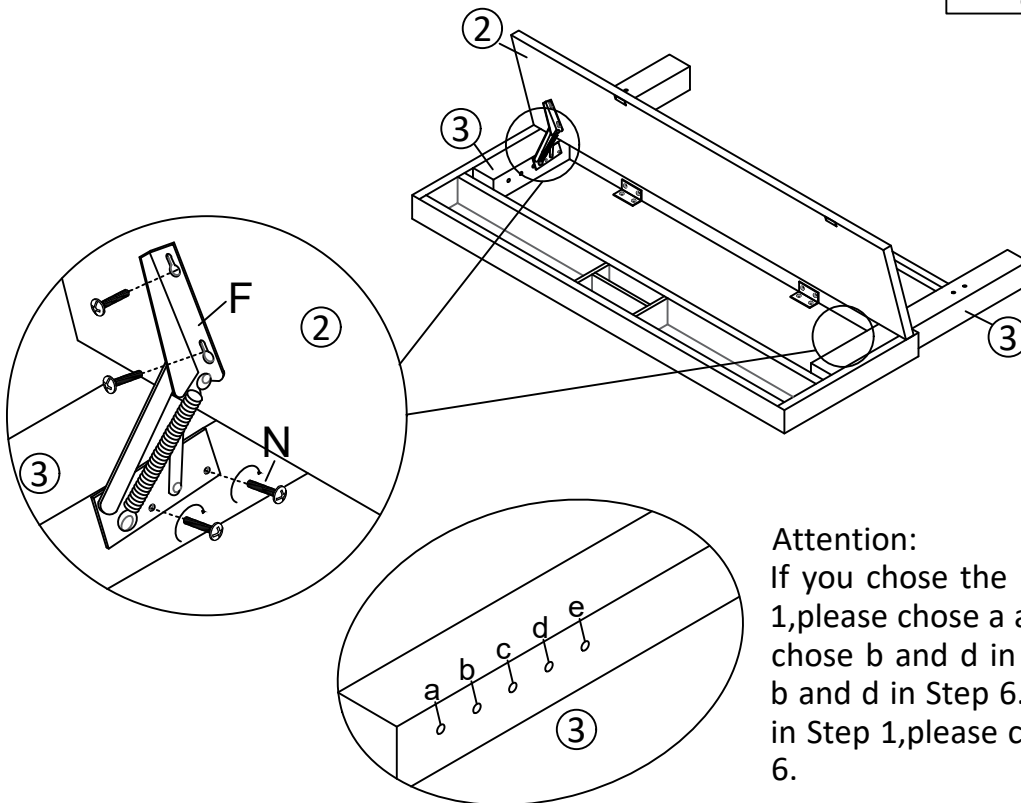
N	F
 M6X15mm	
8PCS	2PCS





Attention:
 If you chose the hole a and c in Step 1, please chose a and c in Step 6. If you chose b and d in Step 1, please chose b and d in Step 6. If you chose c and e in Step 1, please chose c and e in Step 6.

Step 7 x2

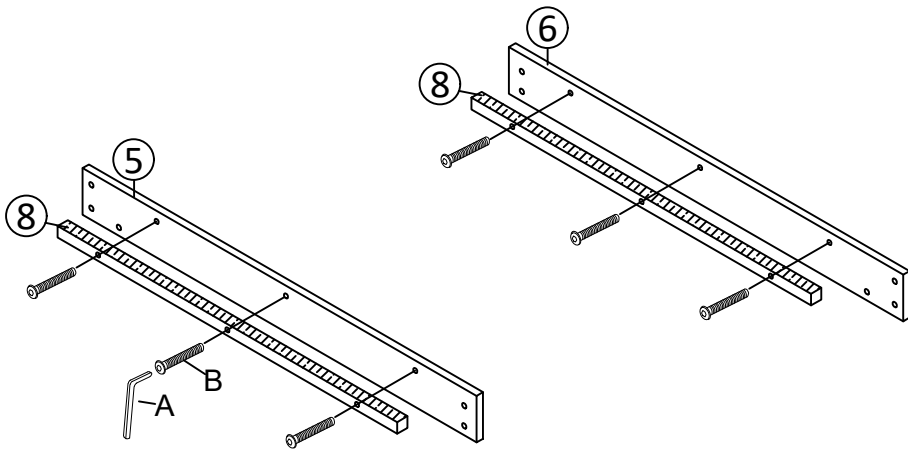
A 	B  M8X40mm 12PCS
---	---



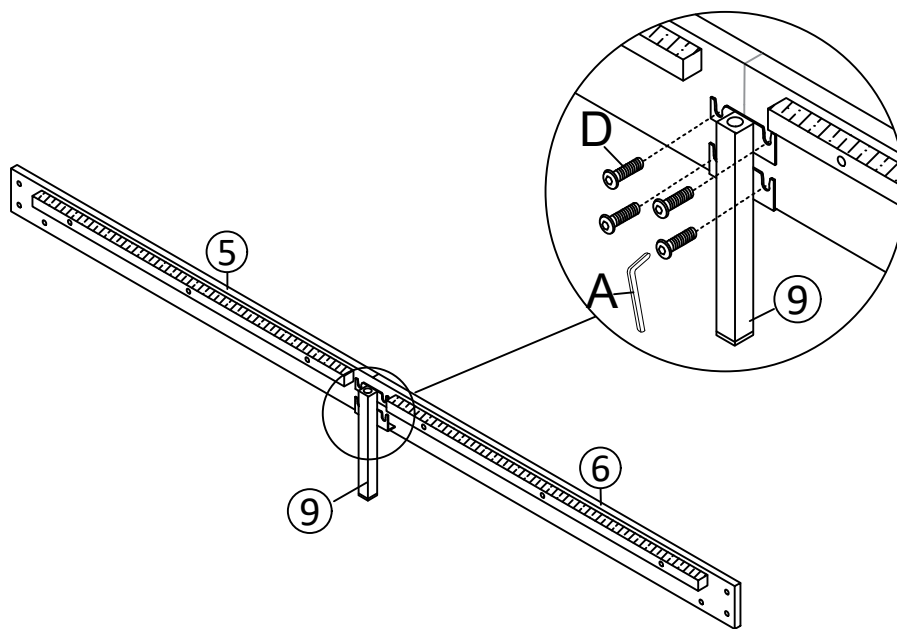

Step 8 x2

A 	D  M8X18mm 8PCS
---	--



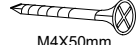

Step 9

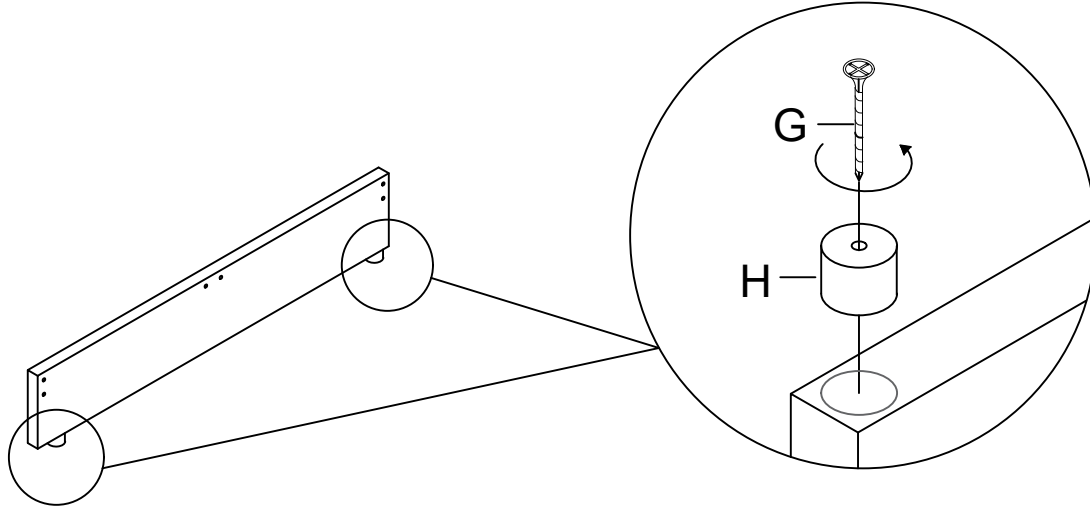
G  M4X50mm	H 
2PCS	2PCS



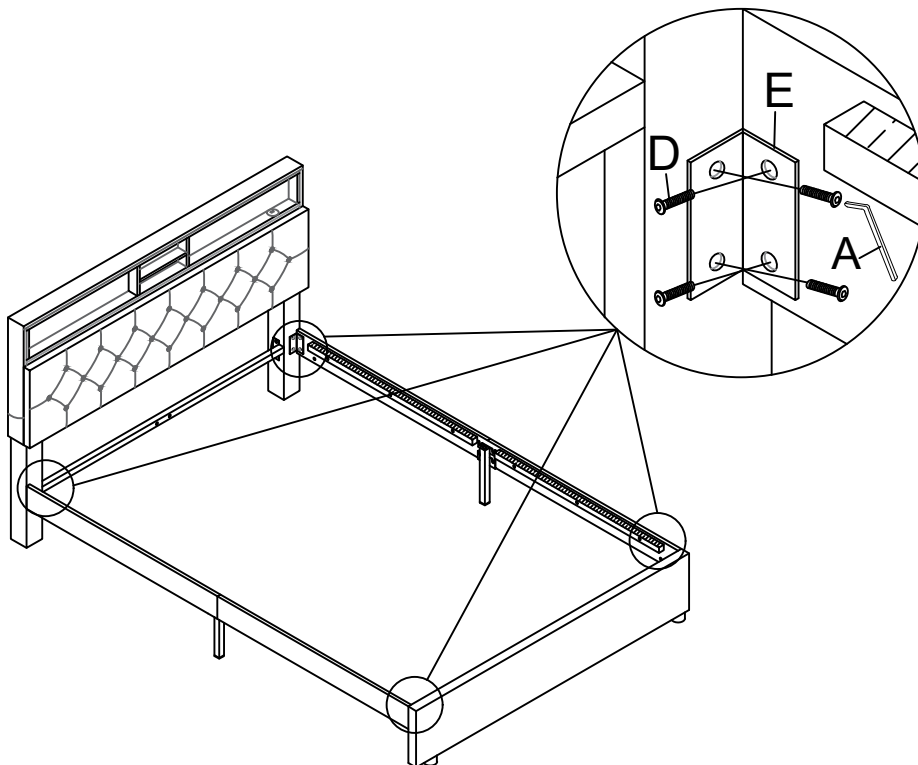

Step 10

A 	D  M8X18mm	E 
16PCS	16PCS	4PCS



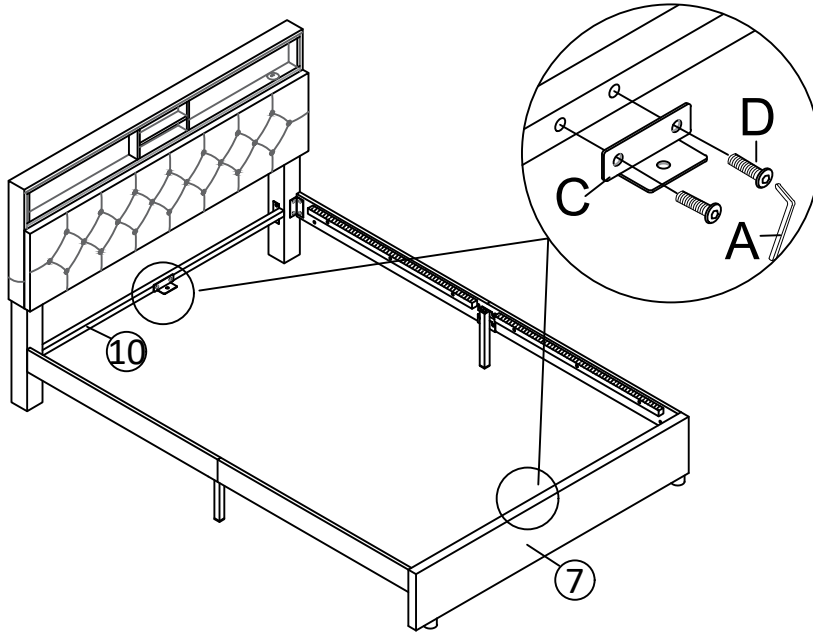

Step 11

A 	C  2PCS	D  M8X18mm 4PCS
--	---	--



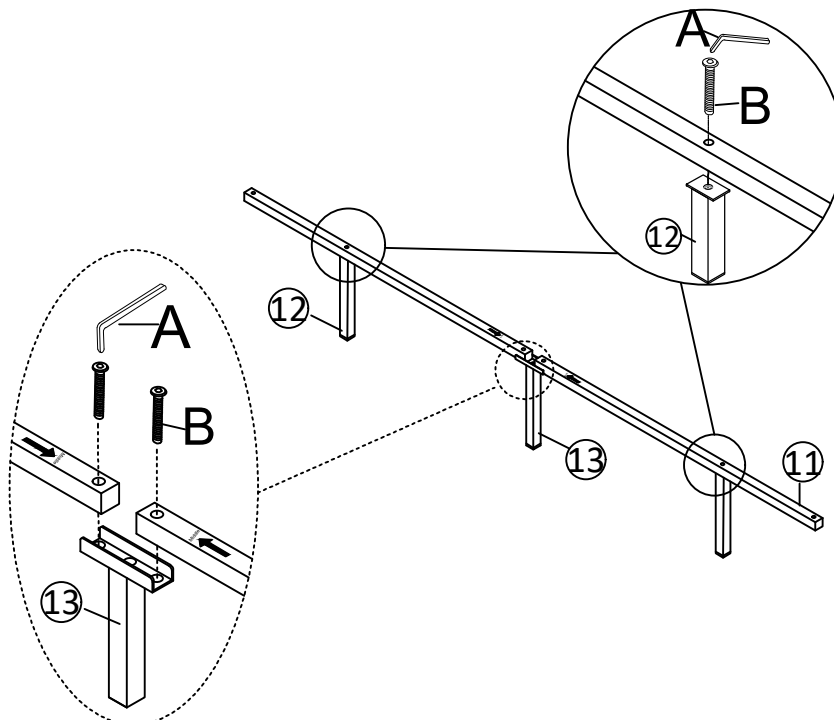

Step 12

A 	B  M8X40mm 4PCS
---	--



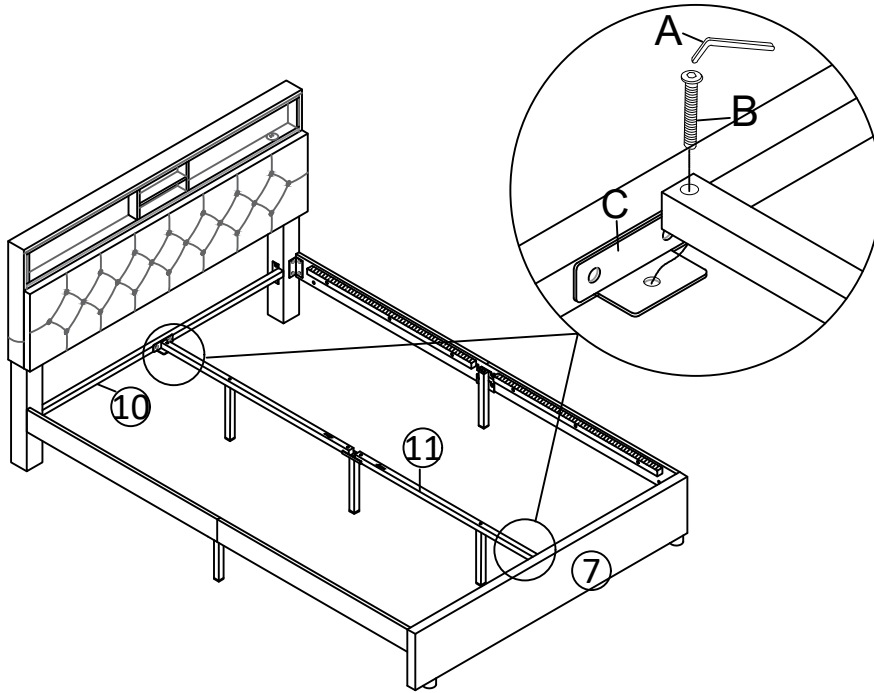

Step 13

A 	B  M8X40mm 2PCS
---	--



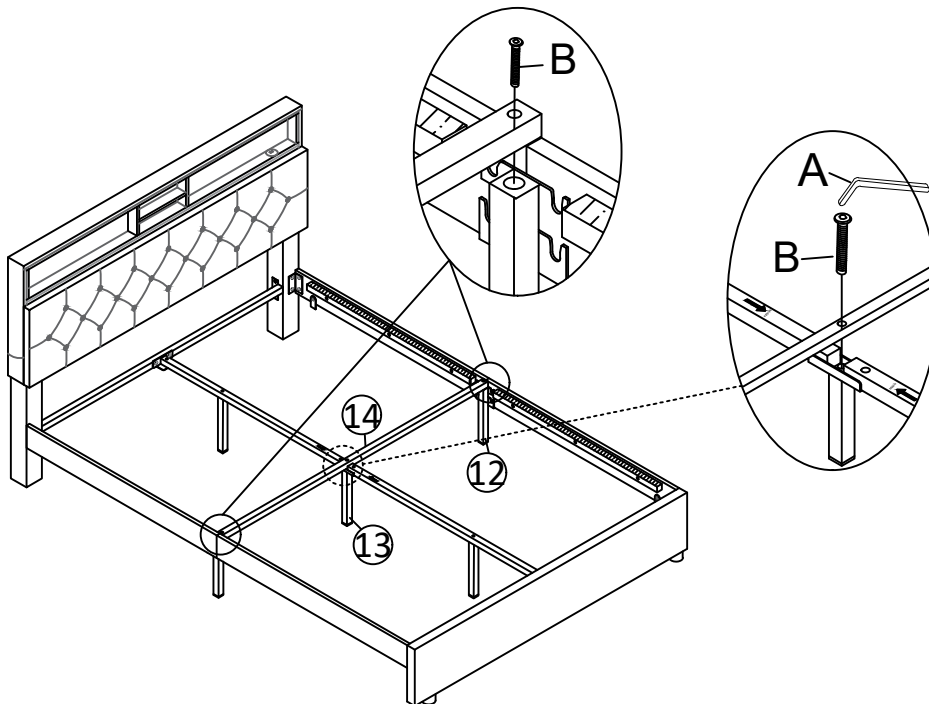

Step 14

A 	B  M8X40mm 3PCS
---	--



Step 15



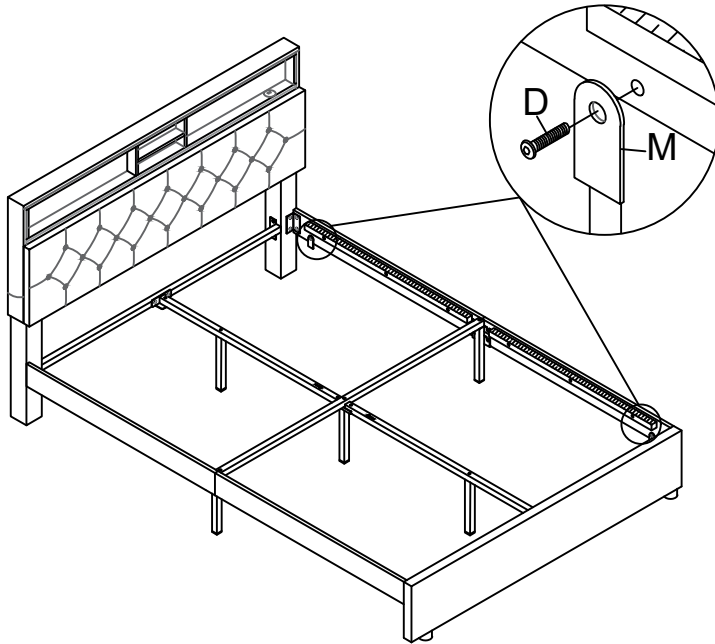

A 	D  M8X18mm 2PCS	M  2PCS
---	---	--

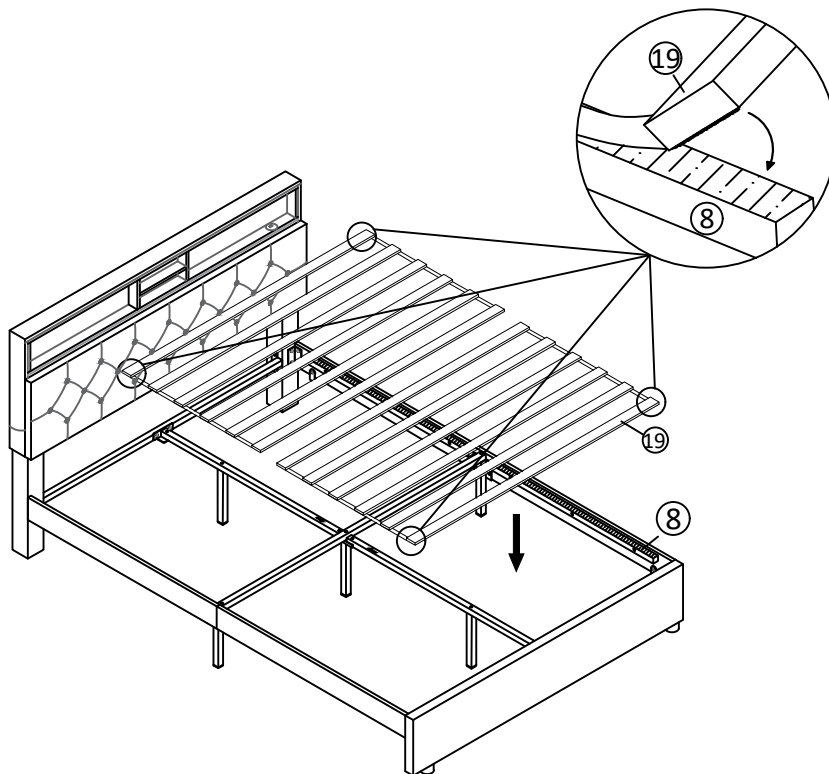

Step 16



Step 17

I  16PCS	J  16PCS	K  M3X20mm 16PCS	L  8PCS
--	---	---	---

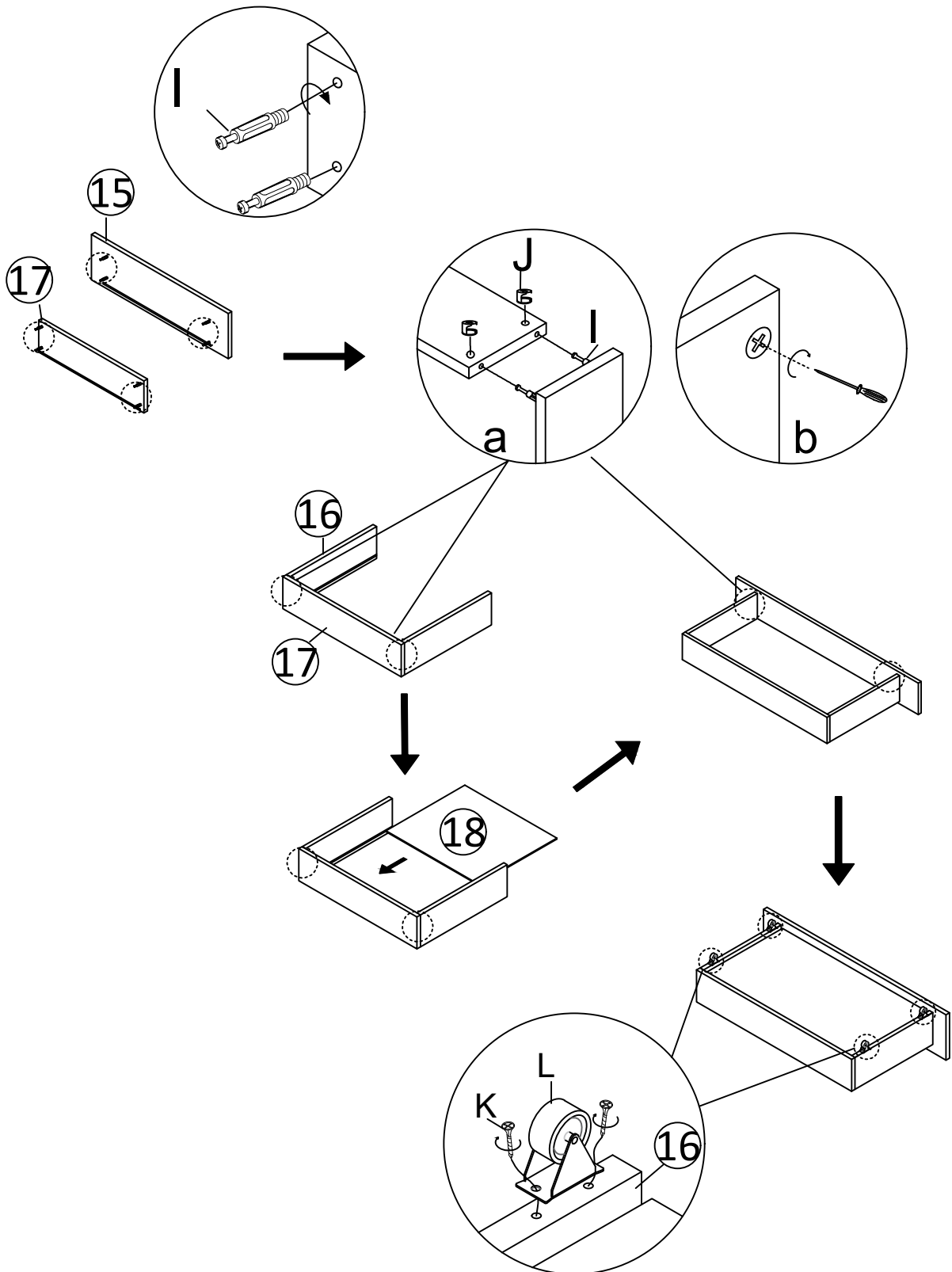

Step 18

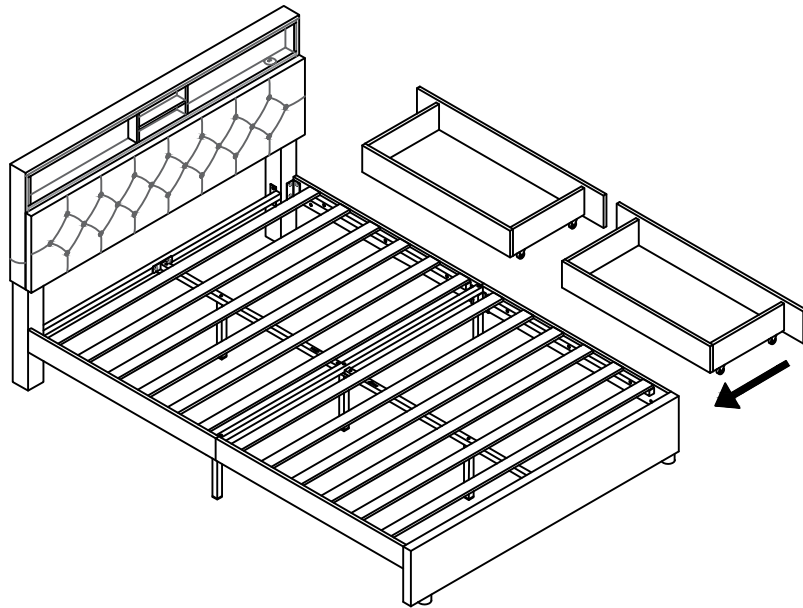

Step 19

O	P	Q
1PC	1PC	1PC

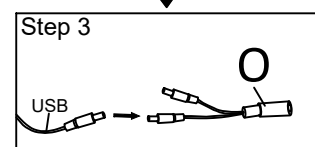
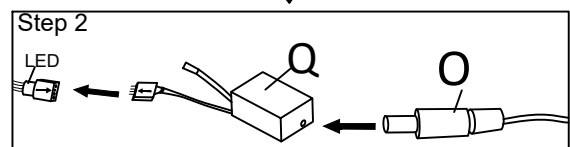
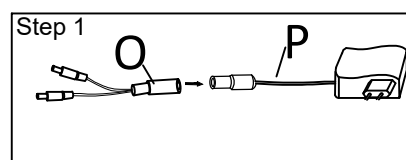
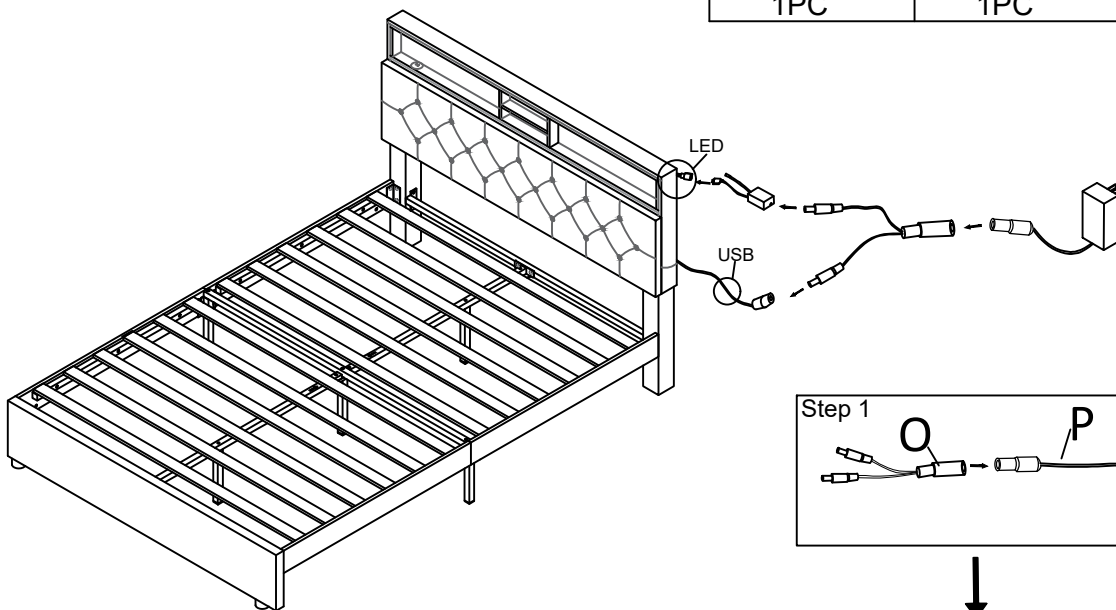

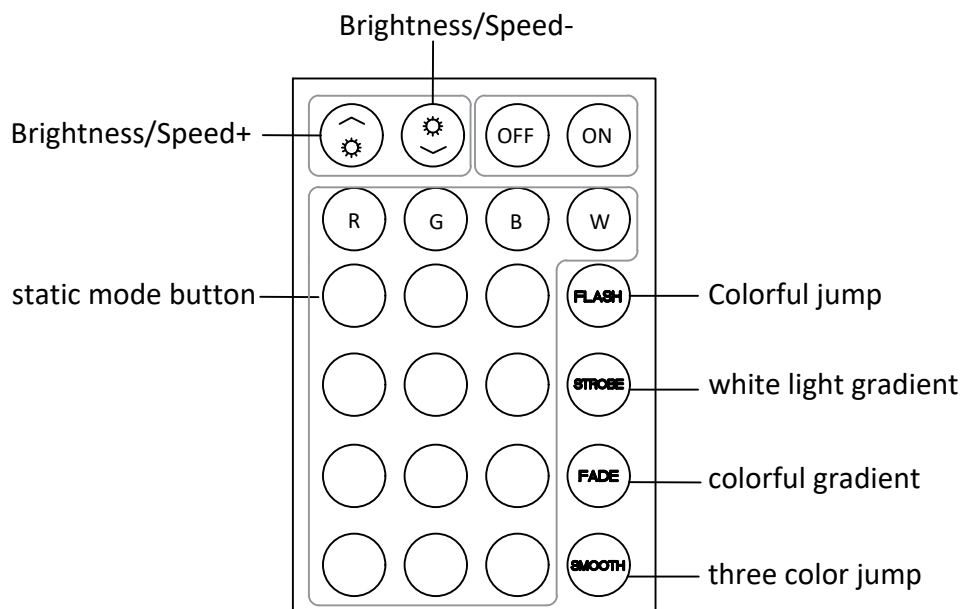

NOTICE:

When you use the remote control board to control the color of the light, Please remove the clear plastic card first, then please be sure to point the remote control at the color controller Q