

## 24" ADA-COMPLIANT SERIES WINE RESERVE

HA24WB-3 24" INDOOR MODEL



Glass Door Model



Solid Door Model

### GENERAL ADA-COMPLIANT SERIES FEATURES



- 32" height with leveling legs
- **Industry Exclusive** front-vented RAPIDcool forced-air refrigeration system provides best-in-class cooling performance
- Commercial-grade stainless steel interior and black vinyl clad exterior
- All models available with stainless steel or panel ready door. Panel ready doors come ready to accept customer-supplied overlay and handle
- **Industry Exclusive** full extension wine shelves provide easy access for stocking and retrieving product. Shelves glide smoothly in and out of cabinet on stainless steel ball bearing glides
- Zero-clearance hinging allows for abutment with surrounding cabinetry
- Interior lighting
- Low E, double pane UV-resistant glass provides exceptional insulation and protection from light
- Comprehensive Full Three Year Warranty plus additional three years on sealed system

### HA24WB FEATURES

- Available with stainless steel solid door, panel ready solid door, stainless steel glass door or panel ready glass door
- Includes four (4) full-extension wine shelves to accommodate 32 bottles plus room for additional storage on the floor of the unit
- Shelves are removable and adjustable to accommodate oversize (magnum) bottles
- Wine Reserve temperature 45° - 65°F

### ACCESSORIES

(L)	Factory Installed Lock
67164	6" Toe Kick Kit (includes riser) for HA24 models
66736	Caster Kit for HP24/HC24/HA24 models

Perlick accessories are available for purchase through an authorized Perlick dealer. For a full list of accessories and to find a dealer near you, visit [perlick.com/residential](http://perlick.com/residential)

## PRODUCT SPECIFICATIONS

Product Width	23-7/8" (606 mm.)
Product Height	32" (813 mm.)
Product Depth	24" (610 mm.)
Opening Width	24" (610 mm.)
Opening Height	32-1/4" (819 mm.)
Opening Depth**	24-7/8" (632 mm.)
Refrigerated Volume	4.8 cu. ft total
Door Swing Clearance	25" (635 mm.)
Electrical	115V, 60Hz., 1 Phase, 2.3 amps
Compressor	525 BTU, standard
Plumbing	None Required
Annual Energy Usage	N/A
Shipping Weight	181 lbs (82.27 kg)

\*\* Includes 7/8" plug clearance. To achieve 24" depth, you must recess the plug into the wall directly behind the unit.

## INDOOR MODELS

HA24WB-3-1L*	Stainless steel solid door, hinge left
HA24WB-3-2L*†	Panel ready solid door, hinge left
HA24WB-3-3L*	Stainless steel glass door, hinge left
HA24WB-3-4L*†	Panel ready glass door, hinge left

\* Also available hinge right (R)

† This unit comes ready to accept customer-provided overlay panel and handle

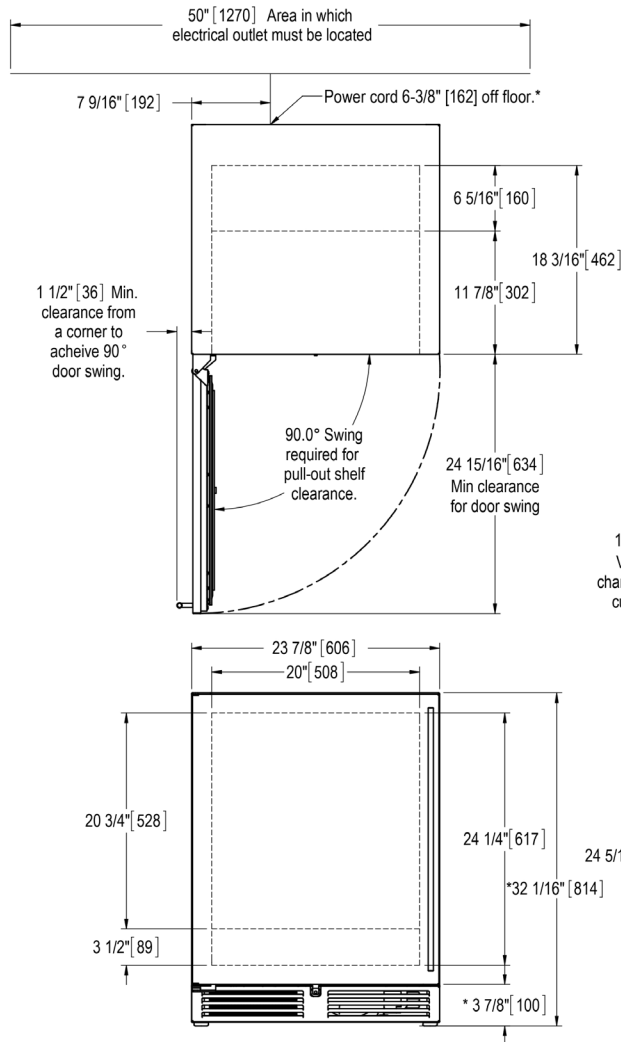

\* - Leg levelers can add 3/4" [19] to these dimensions when fully extended.

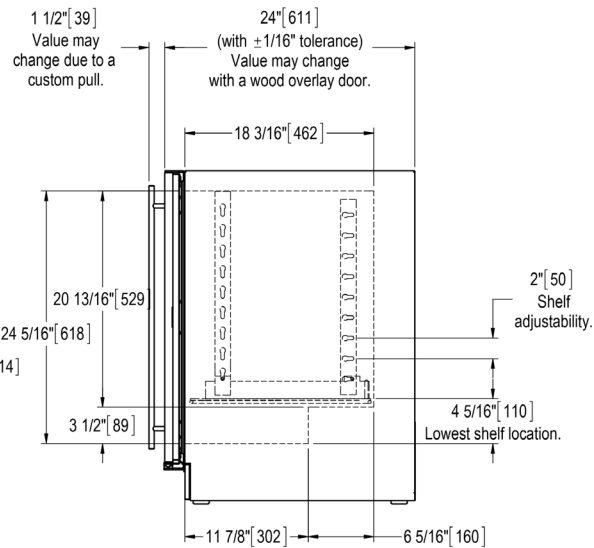

California Prop 65 Notice:

**WARNING:** The materials used in this product may contain chemicals known to the State of California to cause cancer and birth defects or other reproductive harm. For more information go to [www.P65Warnings.ca.gov](http://www.P65Warnings.ca.gov).

FORM NO. Z2525  
REV. B-03/20/2020