

# TP509 Small to Tall Swing Frame

Instructions for assembly, maintenance and safe use.  
Please retain for future reference.

We constantly strive to improve our assembly instructions. To see the most current version of this instruction for assembly, maintenance and safe use. Please visit the product page at [tptoys.com](http://tptoys.com)

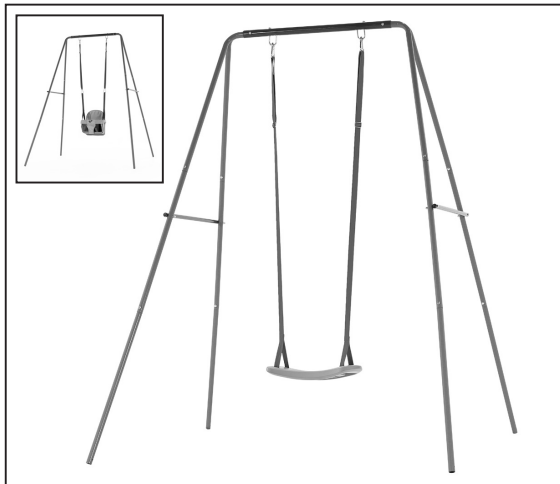

## WARNINGS!

THIS PRODUCT CONTAINS SMALL PARTS AND IS NOT SUITABLE FOR CHILDREN UNDER 36 MONTHS UNTIL FULLY ASSEMBLED.

ONLY FOR DOMESTIC USE. FOR OUTDOOR USE.  
TOY MUST BE ASSEMBLED BY AN ADULT BEFORE USE.  
ADULT SUPERVISION IS REQUIRED.

CHILDREN MUST NOT USE THE EQUIPMENT UNTIL PROPERLY INSTALLED.

REMOVE ALL PACKAGING BEFORE GIVING TO YOUR CHILDREN.

OWNERS SHALL BE RESPONSIBLE FOR MAINTAINING THE LEGIBILITY OF THE WARNING LABELS.

ANCHORS THAT ARE SUPPLIED WITH THIS PRODUCT MUST BE FITTED BEFORE USE.

### Swing Frame

**WARNING:** MAXIMUM USER WEIGHT 100KGS

### TP913 FoldAway Swing Seat

THIS PRODUCT IS INTENDED FOR USE BY CHILDREN FROM AGES 6+ MONTHS.

MAXIMUM USER WEIGHT 45KGS.

NOT SUITABLE FOR OVER 36 MONTHS DUE TO OVERALL SEAT SIZE.

### TP936 Rapide Swing Seat

THIS PRODUCT IS INTENDED FOR USE BY CHILDREN FROM AGES 3+ YEARS.

MAXIMUM USER WEIGHT 60KGS

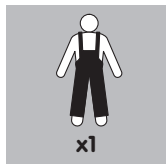

Robovision Ltd t/a TP Toys

Unit 11, Enterprise Way, Flitwick, Bedfordshire, MK45 5BX England

[www.tptoys.com](http://www.tptoys.com)

## EN WARNINGS!

THIS PRODUCT CONTAINS SMALL PARTS AND IS NOT SUITABLE FOR CHILDREN UNDER 36 MONTHS UNTIL FULLY ASSEMBLED. ONLY FOR DOMESTIC USE. FOR OUTDOOR USE. TOY MUST BE ASSEMBLED BY AN ADULT BEFORE USE. ADULT SUPERVISION IS REQUIRED.

CHILDREN MUST NOT USE THE EQUIPMENT UNTIL PROPERLY INSTALLED. REMOVE ALL PACKAGING BEFORE GIVING TO YOUR CHILDREN. OWNERS SHALL BE RESPONSIBLE FOR MAINTAINING THE LEGIBILITY OF THE WARNING LABELS. ANCHORS THAT ARE SUPPLIED WITH THIS PRODUCT MUST BE FITTED BEFORE USE.

**SWING FRAME**  
WARNING: MAXIMUM USER WEIGHT 100KGS

**TP913 FOLDAWAY SWING SEAT**  
THIS PRODUCT IS INTENDED FOR USE BY CHILDREN FROM AGES 6+ MONTHS.  
WARNING: MAXIMUM USER WEIGHT 45KGS.  
NOT SUITABLE FOR OVER 36 MONTHS DUE TO OVERALL SEAT SIZE.

**TP936 RAPIDE SWING SEAT**  
THIS PRODUCT IS INTENDED FOR USE BY CHILDREN FROM AGES 3+ YEARS.  
WARNING: MAXIMUM USER WEIGHT 60KGS

### Instructions for assembly, maintenance and safe use.

1. Toy must be assembled by an adult before use exactly in accordance with the instructions.
2. Children must not use this product until properly installed.
3. Check all parts are present before you start to assemble the product. Place small parts on a tray or similar to ensure they are not lost. The manufacturing process can vary occasionally result in sharp edges/waste material so please take care when assembling this product.
4. If any parts are missing do not use the product until the replacement parts are fitted.
5. Ensure your product is sited on level ground. Failure to do this may put additional stress on connections and joints and in time could cause them to fail.
6. Ensure your product is sited on a soft impact surface like grass. Never locate your product on a hard surface like concrete.
7. Anchors supplied with this product must be fitted before use.
8. In freezing weather, detachable plastic parts should be stored inside.
9. Please retain this information for future reference.
10. Avoid locating this product in full sun.
11. When fitting swinging toys it is vital that no parts have to meet contact.
12. Children should be instructed not to pass in front of or behind moving swings.
13. They should not twist or swing on an empty swing seat. Children should not get on or off a swinging toy when it is in motion.
14. Remove all packaging before giving to your children or allowing them to play with this product.
15. Equipment should be checked by an adult at the beginning of each season and at regular intervals during the usage season to ensure it is safe. Pay special attention to all connections and fastenings. If these checks are not carried out the activity toy could overturn or otherwise become a hazard.
16. Parts may need to be replaced if they show signs of wear and tear. Replace any defective parts in accordance with these instructions.
17. With swings, particular attention should be paid to suspensions systems, ropes and all fixings. Ropes/webbing degrade over time and should be replaced as required.
18. Any changes to this toy including changing or adding an accessory, must be done in accordance with our instructions. Failure to do this will render your guarantee null and void and may make your product unsafe.
19. Ensure children's clothing is appropriate for the play activity.
20. Never place toys near a fire.
21. Take care in wet weather. Toys can become slippery.
22. In high winds, ensure outdoor toys are moved to a sheltered position and/or securely staked down.
23. The age recommendation for this product is clearly stated on the packaging and in these instructions. Please adhere to it at all times. Adult supervision is required at all times to ensure children play safely.
24. When you dispose of this equipment please do so responsibly.

## FR AVERTISSEMENT!

CE PRODUIT CONTIENT DE PETITES PIÈCES ET NE CONVIENT PAS AUX ENFANTS DE MOINS DE 36 MOIS JUSQU'À ENSEMBLE. RÉSERVÉ À UN USAGE DOMESTIQUE. POUR UNE UTILISATION À L'EXTÉRIEUR. AVANT USAGE, LE JOUET DOIT ÊTRE ASSEMBLÉ PAR UN ADULTE CONFORMÉMENT AUX CONSIGNES. À UTILISER SOUS LA SURVEILLANCE D'UN ADULTE.

CE PRODUIT NE DOIT PAS ÊTRE UTILISÉ PAR DES ENFANTS TANT QU'IL N'EST PAS INSTALLÉ CORRECTEMENT. RETIRER TOUT L'EMBALLAGE AVANT DE DONNER CE PRODUIT À SON ENFANT OU AVANT DE L'AUTORISER À JOUER AVEC. CONSERVER L'EMBALLAGE POUR TOUTE RÉFÉRENCE ULTÉRIÈRE. LES PROPRIÉTAIRES SONT RESPONSABLES DE L'ENTRETIEN DE LA LISIBILITÉ DES ÉTIQUETTES D'AVERTISSEMENT. LES FIXATIONS FOURNIES AVEC CE PRODUIT DOIVENT ÊTRE ATTACHÉES AVANT USAGE.

**SWING FRAME**  
POIDS MAXIMUM DE L'UTILISATEUR 100KGS

**TP913 FOLDAWAY SWING SEAT**  
AVERTISSEMENT: CE PRODUIT EST CONÇU POUR LES ENFANTS ÂGÉS DE 6+ MOIS.  
AVERTISSEMENT: POIDS MAXIMUM DE L'UTILISATEUR : 45 KGS.  
PRODUIT DÉCONSEILLÉ POUR LES ENFANTS ÂGÉS DE PLUS DE 36 MOIS.

**TP936 RAPIDE SWING SEAT**  
AVERTISSEMENT: CE PRODUIT EST CONÇU POUR LES ENFANTS ÂGÉS DE 3+ ANS.  
AVERTISSEMENT: POIDS MAXIMUM DE L'UTILISATEUR : 60 KGS.

### Consignes d'assemblage, d'entretien et d'utilisation pour éviter le danger. Veuillez conserver ces informations afin de pouvoir vous y référer plus tard.

1. Les jeux doivent être assemblés par un adulte conformément aux consignes.
2. Ce produit ne doit pas être utilisé par des enfants tant qu'il n'est pas installé correctement.
3. Vérifier que toutes les pièces sont présentes avant de commencer à assembler le produit. Placer les petites pièces sur un plateau ou autre pour veiller à ne pas les perdre. Le processus de fabrication peut, en de très rares occasions, engendrer des rebords tranchants/déchets; il est donc nécessaire de faire attention au moment de l'assemblage de ce produit.
4. S'il manque une pièce, ne pas utiliser le produit jusqu'à l'installation de la pièce de substitution.
5. Veiller à installer le produit sur une surface plane. Sinon, cela risque d'exercer une pression trop importante sur les attaches et les jointures et de provoquer une chute au bout de quelque temps.
6. Veiller à ce que le produit soit situé sur une surface molle, comme de l'herbe. Ne jamais placer le produit sur des surfaces dures, comme du ciment.
7. Les fixations fournies avec ce produit doivent être attachées avant usage.
8. En cas de gel, les pièces amovibles en plastique doivent être remplacées et fixées correctement.
9. Éviter de placer ce produit en plein soleil.
10. Lorsque les jeux de balançoire sont attachés, il est essentiel qu'aucune pièce présente un contact métal contre métal.
11. Indiquer aux enfants de ne pas passer devant ou derrière une balançoire en mouvement.
12. Les enfants ne doivent pas s'enrouler ou se balancer sur un siège de balançoire vide. Les enfants ne doivent pas monter ou descendre d'un jeu qui se balance lorsque celui-ci est en mouvement.
13. Retirer tout l'emballage avant de donner ce produit à son enfant.
14. L'installation doit être vérifiée par un adulte au début de chaque saison et à un intervalle régulier au fur et à mesure de son utilisation pendant la saison pour garantir que son utilisation est sûre. Faire bien attention à toutes ces attaches et fixations.
15. En cas d'usure, certaines pièces pourraient avoir à être remplacées. Remplacer toute pièce défectueuse conformément à ces consignes.
16. Avec les balançoires, faire attention aux systèmes de suspension, aux cordes et à toutes les fixations. Les cordes s'abîment avec le temps et doivent être remplacées lorsque cela est nécessaire.
17. Toute modification apportée à ce jouet (changement ou ajout d'un accessoire, etc.) doit être effectuée conformément à nos consignes. Si ce point n'est pas respecté, cela pourrait entraîner la nullité de la garantie du produit et rendre le produit dangereux.
18. Veiller à ce que les vêtements de l'enfant soient appropriés pour jouer.
19. Ne jamais placer les jouets près d'un feu.
20. Faire attention lorsqu'il pleut. Les jeux peuvent devenir glissants.
21. Lorsqu'il y a du vent, veiller à ce que les jouets soient placés à l'abri ou bien attachés au sol.
22. L'âge recommandé pour utiliser ce produit est indiqué clairement sur l'emballage et dans ces consignes. Veiller à les respecter à tout moment. La surveillance d'un adulte est requise à tout moment pour garantir que les enfants jouent en toute sécurité.
23. Jeter cet équipement de manière responsable.

## DE WARNUNG!

DIESES PRODUKT ENHÄLT KLEINE TEILE UND IST FÜR KINDER UNTER 36 MONATEN BIS ZUR VOLLSTÄNDIGEN MONTAGE NICHT GEEIGNET. NUR FÜR DEN HÄUSLICHEN GEBRAUCH. FÜR DRAUßEN DAS SPIELZEUG MUSS VOR GEBRAUCH VON EINEM ERWACHSENEN GENAU NACH ANLEITUNG ZUSAMMENGEBAUT WERDEN. ALFIRSICHT DURCH EINEN ERWACHSENEN ERFORDERLICH. KINDER DÜRFEN DAS PRODUKT NICHT BENUTZEN, BEVOR ES

NICHT KORREKT AUFGEBAUT WÜRDE. ALLE VERPACKUNGEN ENTFERNEN, BEVOR IHRE KINDER DAS PRODUKT ERHALTEN UND DAMIT SPIELEN DÜRFEN. BITTE DIE VERPACKUNG FÜR ZUKÜNFTIGE VERWENDUNG AUFBEHALTEN. BESITZER TRAGEN DIE VERANTWORTUNG DAFÜR, DASS DIE WARNSCHILDER LESBAR BLEIBEN. DIE MITGELIEFERTEN ANKER MÜSSEN VOR DER VERWENDUNG DES PRODUKTS ANGEBRACHT WERDEN.

**SWING FRAME**  
WARNUNG: MAX. BENUTZERGEWICHT 100KGS

**TP913 FOLDAWAY SWING SEAT**  
WARNUNG: DIESES PRODUKT EIGNET SICH FÜR KINDER ZWISCHEN 6+ MONATEN.  
WARNUNG: MAXIMALES GEWICHT PRO BENUTZER X 45KGS.  
NICHT GEEIGNET FÜR KINDER ÄLTER ALS 36 MONATE.

**TP936 RAPIDE SWING SEAT**  
WARNUNG: DIESES PRODUKT EIGNET SICH FÜR KINDER ZWISCHEN 3+ JAHREN.  
WARNUNG: MAXIMALES GEWICHT PRO BENUTZER 60 KSG

### Zusammenbau-, Wartungs- und Gebrauchsanweisungen. Bitte diese Informationen zur späteren Bezugnahme aufbewahren.

1. Das Spielzeug muss vor Gebrauch von einem Erwachsenen genau nach Anleitung zusammengesetzt werden.
2. Kinder dürfen das Produkt nicht benutzen, bevor es nicht korrekt aufgebaut wurde.
3. Vor Zusammenbau des Produkts überprüfen, dass alle Teile vorhanden sind. Kleine Teile auf ein Tablett oder Ähnliches legen, damit sie nicht verloren gehen. Der Herstellungsprozess kann gelegentlich zu scharfen Kanten/Materialresten führen; seien Sie daher vorsichtig beim Zusammenbau dieses Produkts.
4. Sollten irgendwelche Teile fehlen, das Produkt nicht verwenden, bis Ersatzteile angebracht wurden.
5. Sicherstellen, dass das Produkt auf ebenem Untergrund steht. Bei Nichtbeachtung können die Verbindungsstelle und Gelenke zusätzlicher Belastung ausgesetzt werden und versagen.
6. Sicherstellen, dass Ihr Produkt auf weichem Boden wie Gras steht. Das Produkt niemals auf hartem Boden wie Beton aufstellen.
7. Die mitgelieferten Anker müssen vor der Verwendung des Produkts angebracht werden.
8. Bei Frostwetter sollten die abnehmbaren Kunststoffteile drinnen verstaut werden.
9. Diese Produkt nicht in der vollen Sonne aufstellen.
10. Beim Zusammenbau von Schaukelspielzeug unbedingt darauf achten, dass bei keinen Teilen Metall auf Metall trifft.
11. Kinder sollten darauf hingewiesen werden, nicht vor oder hinter Schaukeln vorbeizulaufen.
12. Sie sollten einen leeren Schaukelstuhl nicht hin- und herschwingen oder verdrehen. Kinder sollten Schaukelspielzeug nicht besteigen oder davon absteigen, während es in Bewegung ist.
13. Alle Verpackungen entfernen, bevor Ihre Kinder das Produkt erhalten und damit spielen dürfen.
14. Geräte sollte zu Beginn jeder Saison sowie regelmäßig während der Gebrauchssaison von einem Erwachsenen überprüft werden, um ihre Sicherheit zu gewährleisten. Besonders auf alle Verbindungen und Befestigungen achten.
15. Teile müssen bei Abnutzungserscheinungen u. U. ersetzt werden. Alle fehlerhaften Teile gemäß diesen Anleitungen ersetzen.
16. Bei Schaukeln sollten vor allem die Aufhängesysteme, Seile und Befestigungselemente überprüft werden. Die Seile nutzen mit der Zeit ab und müssen bei Bedarf ersetzt werden.
17. Bei allen Änderungen des Spielzeugs, z. B. Auswechsell oder Hinzufügen von Zubehör, unsere Anleitungen befolgen. Nichtbeachtung führt zum Erlöschen Ihrer Garantie und kann bedeuten, dass Ihr Produkt nicht länger sicher ist.
18. Für die Spielaktivität geeignete Kinderkleidung wählen.
19. Niemals Spielzeug in der Nähe von Feuer aufstellen.
20. Vorsicht bei schlechtem Wetter. Spielzeug kann rutschig werden.
21. Bei starkem Wind sicherstellen, dass Spielzeug für draußen an eine geschützte Position verlegt wird und/oder fest verankert ist.
22. Das empfohlene Alter für dieses Produkt ist deutlich auf der Verpackung und in diesen Anleitungen angegeben. Bitte sich stets daran halten. Aufsicht durch Erwachsene ist stets erforderlich, um die Sicherheit von Kindern beim Spielen zu gewährleisten.
23. Bitte dieses Gerät verantwortungsvoll entsorgen.

## ES AVISO!

ESTE PRODUCTO CONTIENE PIEZAS PEQUEÑAS Y NO ES APTO PARA NIÑOS MENORES DE 36 MESES. HASTA TOTALMENTE MONTADO.  
SOLO ES APTO PARA USO DOMÉSTICO. PARA USO EN EXTERIORES EL JUGUETE DEBE MONTARLO UN ADULTO ANTES DE SU USO, SIGUIENDO LAS INSTRUCCIONES AL PIE DE LA LETRA.

ES NECESARIA LA SUPERVISIÓN DE UN ADULTO. LOS NIÑOS NO DEBEN UTILIZAR ESTE PRODUCTO HASTA QUE ESTÉ CORRECTAMENTE INSTALADO.  
RETIRAR TODO EL EMBALAJE ANTES DE ENTREGAR ESTE JUGUETE AL NIÑO O PERMITIR QUE JUEGUE CON ESTE PRODUCTO. GUARDAR ESTE EMBALAJE PARA FUTURAS CONSULTAS.  
EL PROPIETARIO SERÁ RESPONSABLE DE MANTENER LEGIBLES LAS ETIQUETAS Y CHADAS DE ADVERTENCIA.  
ANTES DE UTILIZAR EL PRODUCTO DEBEN INSTALARSE LOS ANCLAJES PROVISTOS.

**SWING FRAME**  
AVISO: ALTURA MÁX. DEL USUARIO 100KGS  
**TP913 FOLDAWAY SWING SEAT**  
AVISO: ESTE PRODUCTO ESTÁ DESTINADO PARA SER UTILIZADO POR NIÑOS DE ENTRE 4-6 MESES.  
AVISO: PESO MÁXIMO DE UN SOLO USUARIO: 45 KG  
NO DEBE SER UTILIZADO POR NIÑOS MAYORES DE 36 MESES.  
**TP936 RAPIDE SWING SEAT**  
AVISO: ESTE PRODUCTO ESTÁ DESTINADO A SER UTILIZADO POR NIÑOS DE ENTRE 3+ AÑOS DE EDAD. AVISO: PESO MÁXIMO DE UN SOLO USUARIO: 60 KG

### Instrucciones de montaje, mantenimiento y uso seguro.

1. El juguete debe montarlo un adulto antes de su uso, siguiendo las instrucciones al pie de la letra.
2. Los niños no deben utilizar este producto hasta que esté correctamente instalado.
3. Compruebe que estén todas las piezas antes de empezar a montar el product. Ponga las piezas pequeñas en una bandeja o similar para evitar que se pierdan. El proceso de fabricación puede resultar a veces en bordes o material de desecho cortantes, por lo que se debe llevar cuidado al montar este producto.
4. Si falta alguna pieza, no utilizar el producto hasta que se hayan conseguido e instalado los repuestos correspondientes.
5. Asegúrese de situar el producto sobre un suelo nivelado. De lo contrario las conexiones y las juntas se someterán a una tensión excesiva y podrán fallar pasado un tiempo.
6. Asegúrese de situar el producto sobre una superficie que absorba los impactos, como el césped. No colocar nunca el producto sobre superficies duras como el hormigón.
7. Antes de utilizar el producto deben instalarse los anclajes provistos.
8. Si hay heladas, las piezas de plástico separables se

- deben guardar en el interior.
- Evite colocar este producto a pleno sol.
10. No deben retorcer un columpio vacío ni colgarse de las piezas de metal no hagan contacto con otras piezas de metal.
11. Se debe enseñar a los niños a no pasar por delante ni por detrás de columpios en movimiento.
12. No deben retorcer un columpio vacío ni colgarse del asiento. Los niños no deben subirse ni bajarse del columpio mientras esté en movimiento.
13. Retirar todo el embalaje antes de entregar este juguete al niño o permitir que juegue con este producto.
14. El equipo deberá ser examinado por un adulto al principio de cada temporada, y a intervalos regulares durante la temporada de uso, para cerciorarse de que sea seguro. Prestar atención especialmente a todas las conexiones y fijaciones.
15. Es posible que haya que cambiar las piezas si muestran indicios de desgaste. Sustituir las piezas que estén dañadas o defectuosas de acuerdo con estas instrucciones.
16. Con los columpios se debe prestar especial atención

- a los sistemas de suspensión, las cuerdas y todos los elementos de fijación. Las cuerdas se deterioran con el tiempo y habrá que reemplazarlas cuando sea necesario.
17. Todos los cambios efectuados a este producto (p. ej. añadir un accesorio), deben llevarse a cabo de acuerdo con nuestras instrucciones. De lo contrario, la garantía quedará invalidada y es posible que no resulte seguro utilizar el producto.
18. Asegúrese de que los niños lleven ropa adecuada a la actividad.
19. No colocar nunca los juguetes cerca de hogueras o llamas.
20. Llevar cuidado cuando llueva. Los juguetes pueden estar resbaladizos.
21. Si hace mucho viento, traslade los juguetes de jardín a un sitio resguardado y/o sútelos al suelo.
22. La edad recomendada para este producto se indica claramente en el embalaje y en estas instrucciones. Observe esta recomendación en todo momento. Es necesario la supervisión de un adulto en todo momento para garantizar que los niños jueguen de forma segura.
23. Retire y desheche el embalaje no deseado.

## IT AVVERTENZA!

QUESTO PRODOTTO CONTIENE PICCOLE PARTI E NON È ADATTO AI BAMBINI INFERIORI A 36 MESI FINO AD ASSEMBLARE COMPLETAMENTE.  
SOLO PER USO IN AMBIENTI DOMESTICI. PER USO IN AMBIENTI ESTERNI.  
IL GIOCATTOLO DEVE ESSERE MONTATO DA UN ADULTO PRIMA DELL'USO SEGUENDO ALLA LETTERA LE ISTRUZIONI.  
SI RICHIEDE LA SORVEGLIANZA DI UN ADULTO.

I BAMBINI POSSONO UTILIZZARE QUESTO PRODOTTO SOLO A INSTALLAZIONE AVVENUTA.  
ELIMINARE LA CONFEZIONE PRIMA DI DARE IL GIOCATTOLO AI BAMBINI O PERMETTERE LORO DI UTILIZZARLO.  
CONSERVARE LA CONFEZIONE PER FUTURA CONSULTAZIONE.  
IL PROPRIETARIO SARÀ RESPONSABILE DI MANTENERE LEGIBILI IN HET LEESSAAR HOUDEN VAN DE WAARSCHUWINGSLABELS.  
I PERNI DI FISSAGGIO FORNITI CON QUESTO PRODOTTO DEVONO ESSERE MONTATI PRIMA DELL'USO.

**SWING FRAME**  
AVVERTENZA: PESO MASSIMO DELL'UTENTE: 100KGS

**TP913 FOLDAWAY SWING SEAT**  
AVVERTENZA: QUESTO PRODOTTO È DESTINATO A BAMBINI DI ETÀ COMPRESA TRA I 4+ MESI.  
AVVERTENZA: PESO MASSIMO DELL'UTENTE SINGOLO: 45 KG.  
È VIETATO L'UTILIZZO DA PARTE DI BAMBINI MAGGIORI DI 36 MESI.

**TP936 RAPIDE SWING SEAT**  
AVVERTENZA: QUESTO PRODOTTO È DESTINATO A BAMBINI DI ETÀ COMPRESA TRA 3+ ANNI.  
AVVERTENZA: PESO MASSIMO DELL'UTENTE SINGOLO: 60 KG

### Istruzioni per il montaggio, la manutenzione e l'utilizzo sicuro. Conservare queste informazioni per consultazioni future.

1. I bambini possono utilizzare questo prodotto solo a installazione avvenuta.
2. Verificare che tutte le parti siano presenti prima di iniziare a montare il prodotto. Posizionare le parti piccole su un vassoio o simile affinché non vengano perse.
3. Durante il processo di produzione possono crearsi a volte bordi taglienti/materiali di scarto per cui si raccomanda di prestare la massima attenzione quando si monta il prodotto.
4. In caso di parti mancanti, non utilizzare il prodotto finché non vengano montate le parti di ricambio.
5. Assicurarsi che il prodotto sia posizionato in piano, altrimenti si rischia di provocare ulteriore pressione sui collegamenti e le articolazioni, che col tempo potrebbero cedere.
6. Assicurarsi che il prodotto sia posizionato su una superficie di impatto morbida, come l'erba. Non posizionare mai il prodotto su superfici dure, come il cemento.
7. I perni di fissaggio forniti con questo prodotto devono essere montati prima dell'uso.

8. In condizioni di gelo, le parti in plastica staccabili devono essere riposte al chiuso.
9. Evitare di posizionare questo prodotto in pieno sole.
10. Durante il montaggio delle altalene, è essenziale che le parti di metallo non siano in contatto tra loro.
11. Dire ai bambini di non passare davanti o dietro alle altalene in movimento.
12. Non arrocciare o far oscillare il sedile vuoto dell'altalena. I bambini non devono salire o scendere dall'altalena in movimento.
13. Eliminare la confezione prima di dare il giocattolo ai bambini o permettere loro di utilizzarlo.
14. L'infelicitazione deve essere ispezionata da un adulto all'inizio di ogni stagione e a intervalli regolari durante la stagione d'uso per garantirne la sicurezza. Prestare particolare attenzione a tutti i collegamenti e gli agganci.
15. Potrebbe essere necessario sostituire le parti se presentano segni di usura. Sostituire eventuali parti difettose in conformità a queste istruzioni.
16. In caso delle altalene, è necessario prestare particolare attenzione ai sistemi di sospensione, ai cavi e a tutti gli

- attacchi. I cavi si rovinano col tempo e dovranno essere sostituiti se necessario.
17. Ogni modifica a questo giocattolo (ad es. la sostituzione o aggiunta di un accessorio) deve essere fatta in base alle nostre istruzioni. La mancata osservanza di queste istruzioni renderà nulla la garanzia e potrebbe compromettere la sicurezza del prodotto.
18. Assicurarsi che i bambini indossino abiti consoni al gioco.
19. Non posizionare mai i giocattoli vicino al fuoco.
20. Prestare attenzione in caso di pioggia. I giocattoli possono diventare scivolosi.
21. In caso di forte vento, assicurarsi che i giocattoli siano in una posizione riparata e/o fissati al terreno in modo sicuro.
22. L'età raccomandata per questo prodotto è indicata chiaramente sulla confezione e in queste istruzioni. Rispettare sempre le indicazioni fornite. Si ricorda che è sempre la supervisione di un adulto per accertarsi che i bambini giochino in modo sicuro.
23. Smaltire il prodotto in modo responsabile.

## NL WAARSCHUWING!

DIT PRODUCT KAN KLEINE ONDERDELEN BEVATTEN EN IS NIET GESCHIKT VOOR KINDEREN JONGER DAN 36 MAANDEN TOT HET BIJELAAN IS GEMONTREED.  
ALLEEN VOOR HUISHOUDELIJK GEBRUIK. VOOR GEBRUIK BIJTELSHUIS.  
HET SPEELGOED MOET DOOR EEN VOLWASSEN WORDEN GEMONTREED EN PRODUCT DEBET VERANKERINGEN MOETEN VOÓR GEBRUIK WORDEN GEPLAATST.

TOEZICHT DOOR EEN VOLWASSEN IS VEREIST.  
KINDEREN MOGEN DIT PRODUCT NIET GEBRUIKEN VOORDAT HET JUIST IS GEMONTREED.  
VERWIJDER ALLE VERPAKKINGSMATERIAAL VOORDAT U HET PRODUCT AAN KINDEREN GEEFT OF ZE MET HET PRODUCT LAAT SPELEN.  
BEWAAR DE VERPAKKING OM DEZE LATER TE KUNNEN RAADPLEGEN.  
DE EIGENAAR IS VERANTWOORDELIJK VOOR HET ONDERHOUD EN HET LEESSAAR HOUDEN VAN DE WAARSCHUWINGSLABELS.  
KINDEREN MOETEN DE VERANKERINGEN MOETEN VOÓR GEBRUIK WORDEN GEPLAATST.

**SWING FRAME**  
WAARSCHUWING: MAX. GEWICHT GEBRUIKER 100KGS  
**TP913 FOLDAWAY SWING SEAT**  
WAARSCHUWING: DIT PRODUCT IS BEDEELD VOOR GEBRUIK DOOR KINDEREN VAN 4+ MAANDEN.  
WAARSCHUWING: MAXIMAAL GEWICHT GEBRUIKER 45 KG. NIET GESCHIKT VOOR KINDEREN OUDER DAN 36 MAANDEN.  
**TP936 RAPIDE SWING SEAT**  
WAARSCHUWING: DIT PRODUCT IS BEDEELD VOOR GEBRUIK DOOR KINDEREN VAN 3+ JAAR.  
WAARSCHUWING: MAXIMAAL GEWICHT GEBRUIKER 60 KG

### Instructies voor montage, onderhoud en een veilig gebruik. Berg deze aanwijzingen goed op, mocht u ze later willen raadplegen.

1. Het speelgoed moet door een volwassene worden gemonteerd in overeenstemming met de instructies voordat het mag worden gebruikt.
2. Kinderen mogen dit product niet gebruiken voordat het juist is geïnstalleerd.
3. Controleer of alle onderdelen aanwezig zijn voordat u begint met het monteren van het product. Plaats kleine onderdelen op een dienblad of vergelijkbaar oppervlak zodat ze niet kwijtraan. Het vervaardigingsproces kan er soms toe leiden dat er een scherp randje of afvalmateriaal achterblijft. Wees voorzichtig bij het monteren van dit product.
4. Als er onderdelen ontbreken, gebruik het product dan niet tot vervangende onderdelen zijn geplaatst.
5. Controleer of het product op een vlakke ondergrond is geplaatst. Als dit niet gebeurt, kunnen verbindingen of scharnierstukken onder meer druk komen te staan, waardoor ze in de loop der tijd kapot kunnen gaan.
6. Controleer of het product op een ondergrond met lage impact staat, zoals gras. Plaats het product nooit op een harde ondergrond als beton.
7. De bij dit product geleverde verankeringen moeten vóór gebruik worden geplaatst.

8. Bij koud weer moeten afneembare kunststof onderdelen binnen worden bewaard.
9. Plaats dit product niet in de volle zon.
10. Bij het plaatsen van schommels is het van essentieel belang dat er geen sprake is van metaal-op-metaal-contact tussen onderdelen.
11. Kinderen moeten worden geïnstrueerd om niet vlak voor of achter een bewegende schommel langs te lopen.
12. Ze mogen een schommel waar niemand op zit, niet rondraaien of los laten schommelen. Kinderen mogen niet op een schommel gaan zitten of eraf komen wanneer deze in beweging is.
13. Verwijder alle verpakkingsmateriaal voordat u het product aan kinderen geeft of ze met het product laat spelen.
14. De apparatuur moet ook aan het begin van elk seizoen en periodiek tijdens gebruiksmomenten worden geïnspecteerd om te waarborgen dat deze veilig is. Besteed extra aandacht aan alle verbindingen en bevestigingen.
15. Als onderdelen tekenen van slijtage vertonen, kan het nodig zijn deze te vervangen. Vervang defecte onderdelen in overeenstemming met deze handleiding.
16. Bij schommels moet extra aandacht worden besteed

- aan ophangsystemen, touwen en alle bevestigingen. De touwen gaan in de loop der tijd achteruit en moeten indien nodig worden vervangen.
17. Erige wijziging aan dit speelgoed zoals het veranderen of toevoegen van toebehoren, moet worden uitgevoerd in overeenstemming met onze handleiding. Als dit niet gebeurt, komt de garantie te vervallen en kan het product onveilig worden.
18. Controleer of de kleding van kinderen geschikt is voor de spelactiviteit.
19. Plaats speelgoed nooit in de buurt van open vuur.
20. Wees voorzichtig bij nat weer. Speelgoed kan glad worden.
21. Zorg er bij harde wind voor dat speelgoed dat buiten staat opgesteld, op een beschermde locatie wordt geplaatst en/of veilig wordt verankerd.
22. De leeftijdsaanbeveling voor dit product staat duidelijk aangegeven op de verpakking en in deze handleiding. Houd u hier te allen tijde aan. Toezicht door volwassene(n) is te allen tijde vereist om te waarborgen dat kinderen veilig spelen.
23. Wanneer u deze apparatuur weggooit, doe dit dan op verantwoorde wijze.





## Warnings

THIS PRODUCT CONTAINS SMALL PARTS AND IS NOT SUITABLE FOR CHILDREN UNDER 36 MONTHS UNTIL FULLY ASSEMBLED. ONLY FOR DOMESTIC USE. FOR OUTDOOR USE. TOY MUST BE ASSEMBLED BY AN ADULT BEFORE USE. ADULT SUPERVISION IS REQUIRED. CHILDREN MUST NOT USE THE EQUIPMENT UNTIL PROPERLY INSTALLED. REMOVE ALL PACKAGING BEFORE GIVING TO YOUR CHILDREN. OWNERS SHALL BE RESPONSIBLE FOR MAINTAINING THE LEGIBILITY OF THE WARNING LABELS. ANCHORS THAT ARE SUPPLIED WITH THIS PRODUCT MUST BE FITTED BEFORE USE.

### SWING FRAME

**WARNING:** MAXIMUM USER WEIGHT 100KGS

### TP913 FOLDAWAY SWING SEAT

**WARNING:** THIS PRODUCT IS INTENDED FOR USE BY CHILDREN FROM AGES 6 MONTHS TO 3 YEARS.

**WARNING:** MAXIMUM USER WEIGHT 45KGS NOT SUITABLE FOR OVER 36 MONTHS DUE TO OVERALL SEAT SIZE.

### TP936 RAPIDE SWING SEAT

**WARNING:** THIS PRODUCT IS INTENDED FOR USE BY CHILDREN FROM AGES 3 YEARS TO 10 YEARS.

**WARNING:** MAXIMUM USER WEIGHT 60KGS



## WARNING:

ADULT ASSEMBLY REQUIRED



### Important advice for assembly, maintenance and safe use

1. Toy must be assembled by an adult before use exactly in accordance with the instructions.
2. Children must not use this product until properly installed.
3. Check all parts are present before you start to assemble the product. Place small parts on a tray or similar to ensure they are not lost. The manufacturing process can very occasionally result in sharp edges/ waste material so please take care when assembling this product.
4. If any parts are missing do not use the product until the replacement parts are fitted.
5. Ensure your product is sited on level ground. Failure to do this may put additional stress on connections and joints and in time could cause them to fail.
6. Ensure your product is located on a soft impact surface like grass. Never locate your product on a hard surfaces like concrete.
7. Anchors supplied with this product must be fitted before use.
8. In freezing weather, detachable plastic parts should be stored inside.
9. Avoid locating this product in full sun.
10. When fitting swinging toys it is vital that no parts have metal to metal contact.
11. Children should be instructed not to pass in front of or behind moving swings.
12. They should not twist or swing on an empty swing seat. Children should not get on or off a swinging toy when it is in motion.

### Safe play free space area

The Safe Play Area refers to the zone extending 200cm beyond the toy on all sides, including the space above the toy. The Safe Play Area must be free from all structures, landscaping, trees and branches, rocks, wires, sprinkler heads and other similar obstacles to safe play. Children can be seriously injured running or colliding into such obstacles.

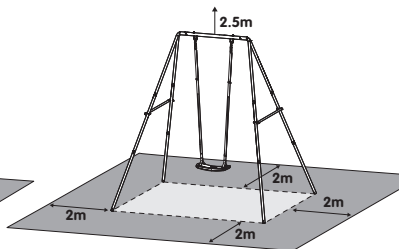
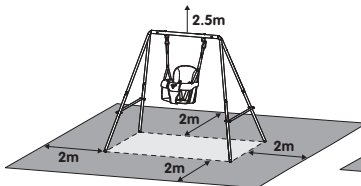

13. Remove all packaging before giving to your children or allowing them to play with this product.
14. Equipment should be checked by an adult at the beginning of each season and at regular intervals during the usage season to ensure it is safe. Pay special attention to all connections and fastenings.
15. Parts may need to be replaced if they show signs of wear and tear. Replace any defective parts in accordance with these instructions.
16. With swings, particular attention should be paid to suspensions systems, ropes and all fixings. Ropes degrade over time and should be replaced as required.
17. Any changes to this toy including changing or adding an accessory, must be done in accordance with our instructions. Failure to do this will render your guarantee null and void and may make your product unsafe.
18. Never add extra length to chain or rope. The chains or ropes provided are the maximum length designed for the swinging element(s).
19. Ensure children's clothing is appropriate for the play activity.
20. Never place toys near a fire.
21. Take care in wet weather. Toys can become slippery.
22. In high winds, ensure outdoor toys are moved to a sheltered position and/or securely staked down.
23. The age recommendation for this product is clearly stated on the packaging and in these instructions. Please adhere to it at all times. Adult supervision is required at all times to ensure children play safely.
24. When you dispose of this equipment please do so responsibly.



### CONSUMER INFORMATION SHEET FOR PLAYGROUND SURFACING MATERIALS

The U.S. Consumer Product Safety Commission (CPSC) estimates that about 100 000 playground equipment related injuries resulting from falls to the ground surface are treated annually in U.S. hospital emergency rooms. Injuries involving this hazard pattern tend to be among the most serious of all playground injuries, and have the potential to be fatal, particularly when the injury is to the head. The surface under and around playground equipment can be a major factor in determining the injury-causing potential of a fall. It is self evident that a fall onto a shock absorbing surface is less likely to cause a serious injury than a fall onto a hard surface.

Playground equipment should never be placed on hard surfaces such as concrete or asphalt and while grass may appear to be acceptable it may quickly turn to hard packed earth in areas of high traffic. Shredded bark mulch, wood chips, fine sand or fine gravel are considered to be

acceptable shock absorbing surfaces when installed and maintained at a sufficient depth under and around playground equipment.

**X3.1 Select Protective Surfacing** - One of the most important things you can do to reduce the likelihood of serious head injuries is to install shock-absorbing protective surfacing under and around your play equipment. The protective surfacing should be applied to a depth that is suitable for the equipment height in accordance with ASTM Specification F 1292. There are different types of surfacing to choose from; whichever product you select, follow these guidelines:

#### X3.1.1 Loose-Fill Materials:

**X3.1.1.1** Maintain a minimum depth of 9 inches of loose fill materials such as wood mulch/chips, engineered wood fiber (EWF), or shredded/ recycled rubber mulch for equipment up to 8 feet high; and 9 inches of sand or pea gravel for equipment up to 5 feet high. NOTE: An initial fill level of 12 inches will compress to about a 9-inch depth of surfacing over time. The surfacing will also compact, displace, and settle, and should be periodically refilled to maintain at least a 9-inch depth.

**X3.1.2** Use a minimum of 6 inches of protective surfacing for play equipment less than 4 feet in height. If maintained properly, this should be adequate. (At depths less than 6 inches, the protective material is too easily displaced or compacted.)

**NOTE:** Do not install home playground equipment over concrete, asphalt, or any other hard surface. A fall onto a hard surface can result in serious injury to the equipment user. Grass and dirt are not considered protective surfacing because wear and environmental factors can reduce their shock absorbing effectiveness. Carpeting and thin mats are generally not adequate protective surfacing. Ground level equipment – such as a sandbox, activity wall, playhouse or other equipment that has no elevated play surface – does not need any protective surfacing.

**X3.1.3** Use containment, such as digging out around the perimeter and/or lining the perimeter with landscape edging. Don't forget to account for water drainage.

**X3.1.3.1** Check and maintain the depth of the loose-fill surfacing material. To maintain the right amount of loose-fill materials, mark the correct level on play equipment support posts. That way you can easily see when to replenish and/or redistribute the surfacing.

**X3.1.3.2** Do not install loose fill surfacing over hard surfaces such as concrete or asphalt.

**X3.1.4** Poured-In-Place Surfaces or Pre-Manufactured Rubber Tiles - You may be interested in using surfacing other than loose-fill materials – like rubber tiles or poured-in-place surfaces.

**X3.1.4.1** Installations of these surfaces generally require a professional and are not "do-it-yourself" projects.

**X3.1.4.2** Review surface specifications before purchasing this type of surfacing. Ask the installer/manufacturer for a report showing that the product has been tested to the following safety standard: ASTM F 1292 Standard Specification for Impact Attenuation of Surfacing Materials within the Use Zone of Playground Equipment. This report should show the specific height for which the surface is intended to protect against serious head injury. This height should be equal to or greater than the fall height – vertical distance between a designated play surface (elevated surface for standing, sitting, or climbing) and the protective surfacing below – of your play equipment.

**X3.1.4.3** Check the protective surfacing frequently for wear.

**X3.1.5** Placement - Proper placement and maintenance of protective surfacing is essential. Be sure to:

**X3.1.5.1** Extend surfacing at least 6 feet from the equipment in all directions.

**X3.2 Table X3.1** lists the maximum height from which a child would not be expected to sustain a life-threatening head injury in a fall onto four different loose-fill surfacing materials if they are installed and maintained at depths of 6, 9, and 12 in. However, it should be recognized that all injuries due to falls cannot be prevented no matter what surfacing material is used.

**X3.3** It is recommended that a shock absorbing material should extend a minimum of 6 ft in all directions from the perimeter of stationary equipment such as climbers and slides. However, because children may deliberately jump from a moving swing, the shock absorbing material should extend in the front and rear of a swing a minimum distance of 2 times the height of the pivot point measured from a point directly beneath the pivot on the supporting structure.

**X3.4** This information is intended to assist in comparing the relative shock-absorbing properties of various materials. No particular material is recommended over another. However, each material is only effective when properly maintained. Materials should be checked periodically and replenished to maintain correct depth as determined necessary for your equipment. The choice of a material depends on the type and height of the playground equipment, the availability of the material in your area, and its cost.

**9** This information has been extracted from the CPSC publications "Playground Surfacing - Technical Information Guide" and "Handbook for Public Playground Safety." Copies of these reports can be obtained by sending a postcard to the: Office of Public Affairs, U.S. Consumer Product Safety Commission, Washington, D.C., 20207 or call the toll-free hotline: 1-800-638-2772.

**TABLE X3.1**

**Fall Height in Feet From Which a Life Threatening Head Injury Would Not Be Expected**

Type of Material	6 inch. depth	9 inch. depth	12 inch. depth
Double Shredded Bark Mulch	6	10	11
Wood Chips	6	7	12
Fine Sand	5	5	9
Fine Gravel	6	7	10

## Warning

Please instruct children not to use the equipment in a manner other than intended.

### Installation Instructions and Information -

Place the equipment on level ground, not less than 6ft (1.8m) from any structure or obstruction such as a fence, Garage, house, overhanging branches, laundry lines, or electrical wires.

Do not install home playground equipment over concrete, asphalt, packed earth, or any other hard surface. A fall onto a hard surface can result in serious injury to the equipment user.

### Operating Instructions -

Observing the following statements and warnings reduces the likelihood of serious or fatal injury.

We recommend on-site adult supervision for children of all ages Instruct children not to walk close to, in front of, behind, or between moving items.

Instruct children not to twist swing chains or ropes or loop them over the top support bar since this may reduce the strength of the chain or rope. Instruct children to avoid swinging empty seats.

Teach children to sit in the center of the swings with their full weight on the seats.

Instruct children not to use the equipment in a manner other than intended.

Instruct children not to get off equipment while it is in motion.

Parent to dress children appropriately (examples would include the use of well-fitting shoes and the avoidance of ponchos, scarfs, and other loose-fitting clothing that is potentially hazardous while using equipment).

Instruct children not to climb when the equipment is wet.

Check the openings between rollers and sliding surfaces of roller slides for foreign materials that could be potentially hazardous to users.

Verify that suspended climbing ropes, chain, or cable cannot be looped back on itself.

Instruct children not to attach items to the playground equipment that are not specifically designed for use with the equipment, such as, but not limited to, jump ropes, clothesline, pet leashes, cables and chain as they may cause a strangulation hazard.

**Warning!** the buyer to instruct children to remove their bike or other sports helmet before playing on the playground equipment.

**WARNING:** Lawn swings are designed for use by children two years of age and older. The use by children under the age of two can result in entrapment between the seat and back rest because the child's body may pass through the opening, causing entrapment of the child's head. Such entrapment may result in strangulation. **NEVER** place children in a rearward facing position or with legs between the seat and backrest.

## Maintenance Instructions -

### At the beginning of each play season:

Tighten all hardware. Lubricate all metallic moving parts per manufacturer's instructions.

Check all protective coverings on bolts, pipes, edges, and corners. Replace if they are loose, cracked, or missing. Check all moving parts including swing seats, ropes, cables, and chains for wear, rust, or other deterioration. Replace as needed. Check metal parts for rust. If found, sand and repaint using a non lead-based paint meeting the requirements of 16 CFR 1303.

Check all wood members for deterioration and splinters. Sand down splinters and replace deteriorating wood members. Reinstall any plastic parts, such as swing seats or any other items that were removed for the cold season. Rake and check depth of loose fill protective surfacing materials to prevent compaction and to maintain appropriate depth. Replace as necessary.

### Twice a month during play season:

Tighten all hardware. Check all protective coverings on bolts, pipes, edges, and corners. Replace if they are loose, cracked, or missing. Rake and check depth of loose fill protective surfacing materials to prevent compaction and to maintain appropriate depth. Replace as necessary.

### Once a month during play season:

Lubricate all metallic moving parts per manufacturer's instructions.

Check all moving parts including swing seats, ropes, cables, and chains for wear, rust, or other deterioration. Replace as needed.

At the end of each play season or when the temperature drops below 40°F (4°C). Remove plastic swing seats and other items as specified by the manufacturer and take indoors or do not use. Rake and check depth of loose fill protective surfacing materials to prevent compaction and to maintain appropriate depth. Replace as necessary.



FC0124 **x2**

FC0125 **x4**

FC0127 **x4**

FC0130 **x1**

FC0129 **x2**

FC0123 **x2**

PM1903 **x2**

PR9662 **x4**

**SP9908**

M8 x 83mm FA8057 **x2**

30mm FA2825 **x2**

M6 x 42mm FA5199 **x2**

M6 x 50mm FA5155 **x4**

M6 x 32mm FA7250 **x12**

M6 FA5192 **x2**

M6 FA9023 **x16**

M6 FA9764 **x18**

10 & 13mm **x1**

5mm FA8414 **x1**

TP936 **x1**

TP913 **x1**

FC9908 **x2**

WF9787 **x2**

FB9030 **x2**

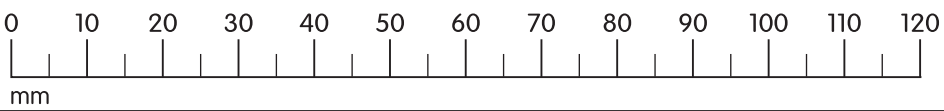

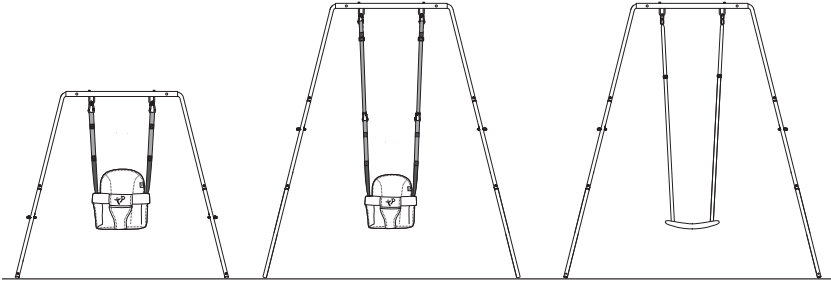

**1**

**Low Height Frame Assembly**

**Full Height Frame Assembly**

FC0130 **x1**



PM1903 **x2**



**2**

**Low Height Frame Assembly**

**Full Height Frame Assembly**



M6 x 42mm  
FA5199 **x2**



M6  
FA5192 **x2**



M6  
FA9764 **x2**

FC0124 **x2**

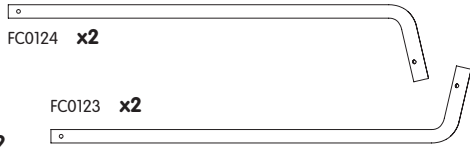

FC0123 **x2**

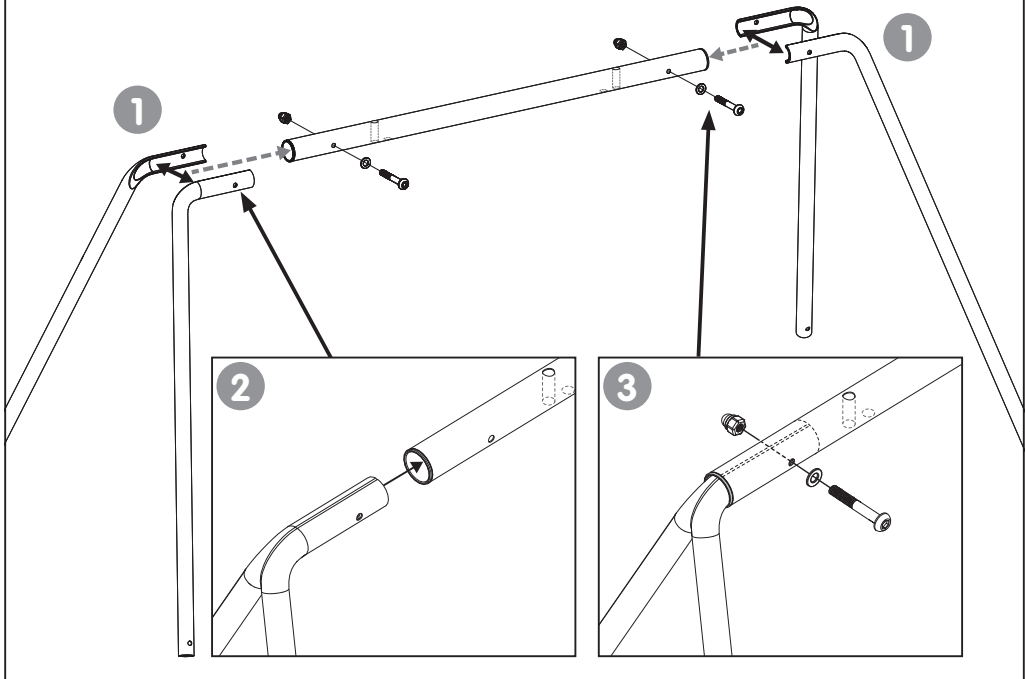
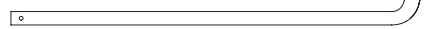

**8**

TP509 Small to Tall Swing Frame

3

Low Height Frame Assembly

Full Height Frame Assembly

FC0127 x4

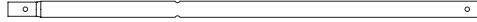

M6 x 32mm  
FA7250 x4



M6  
FA9764 x4



M6  
FA9023 x4

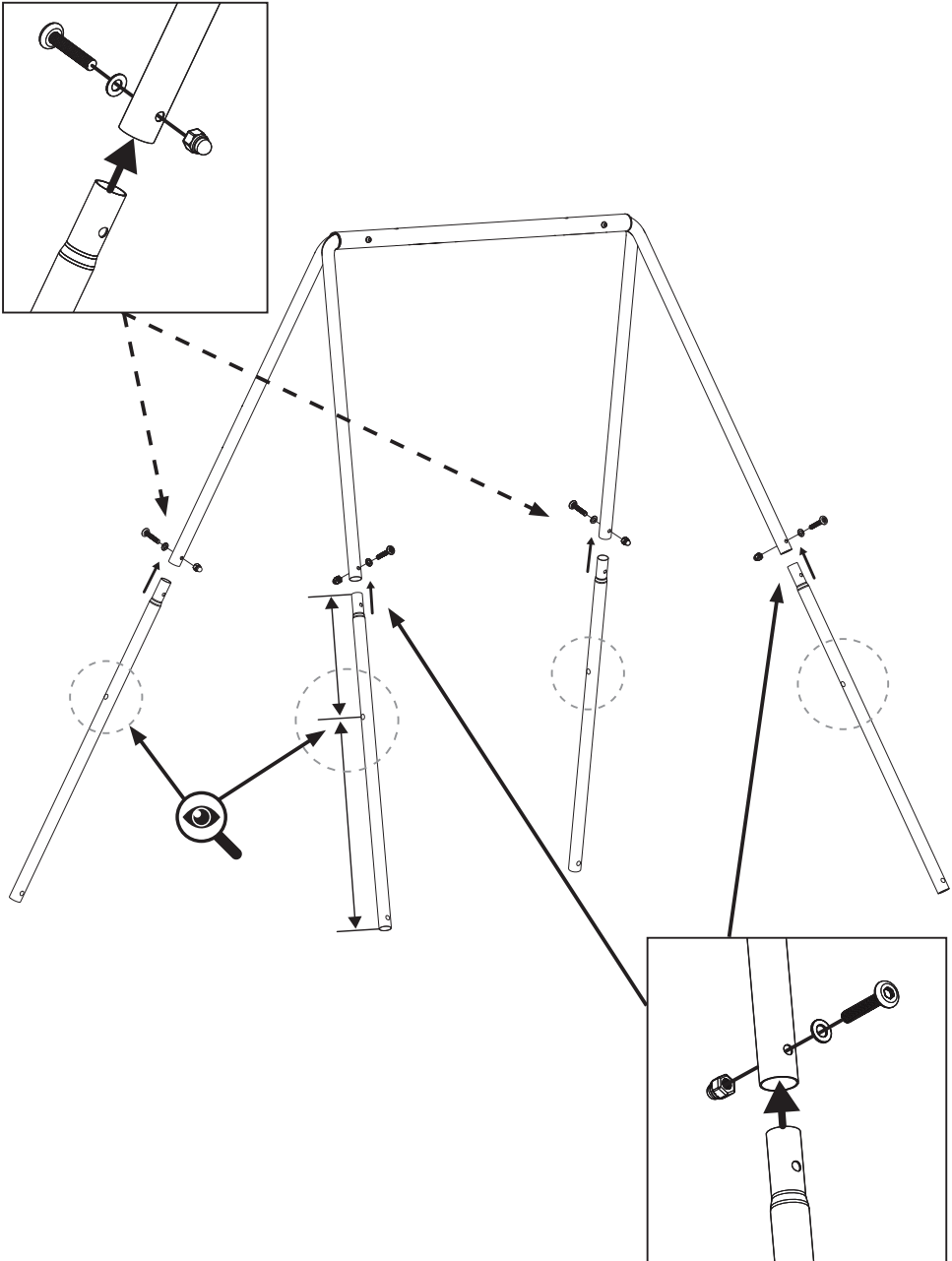

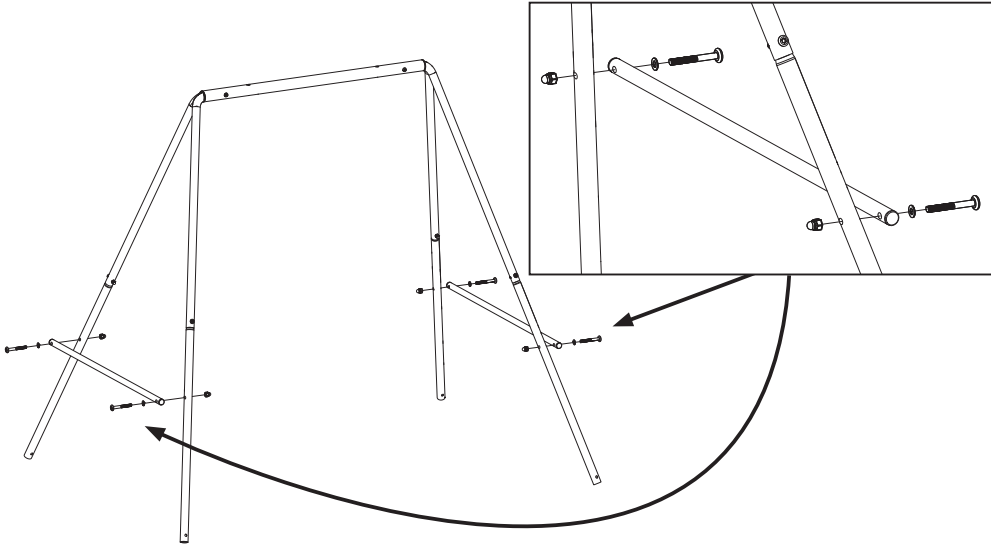
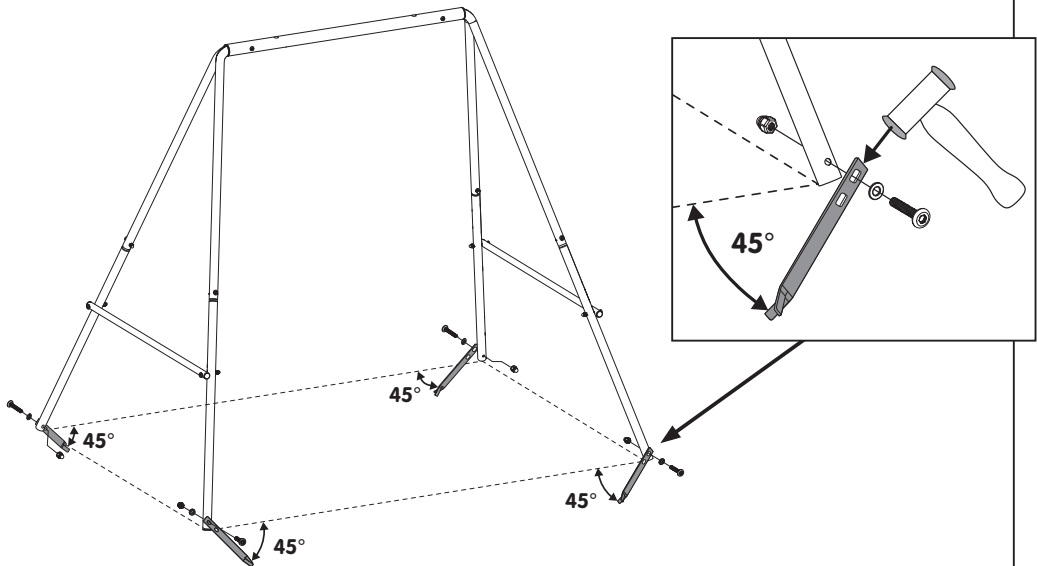
**4****Low Height Frame Assembly****Full Height Frame Assembly**FC0129 **x2**M6 x50mm  
FA5155 **x4**M6  
FA9764 **x4**M6  
FA9023 **x4****5****Low Height Frame Assembly**PR9662 **x4**M6 x 32mm  
FA7250 **x4**M6  
FA9764 **x4**M6  
FA9023 **x4**

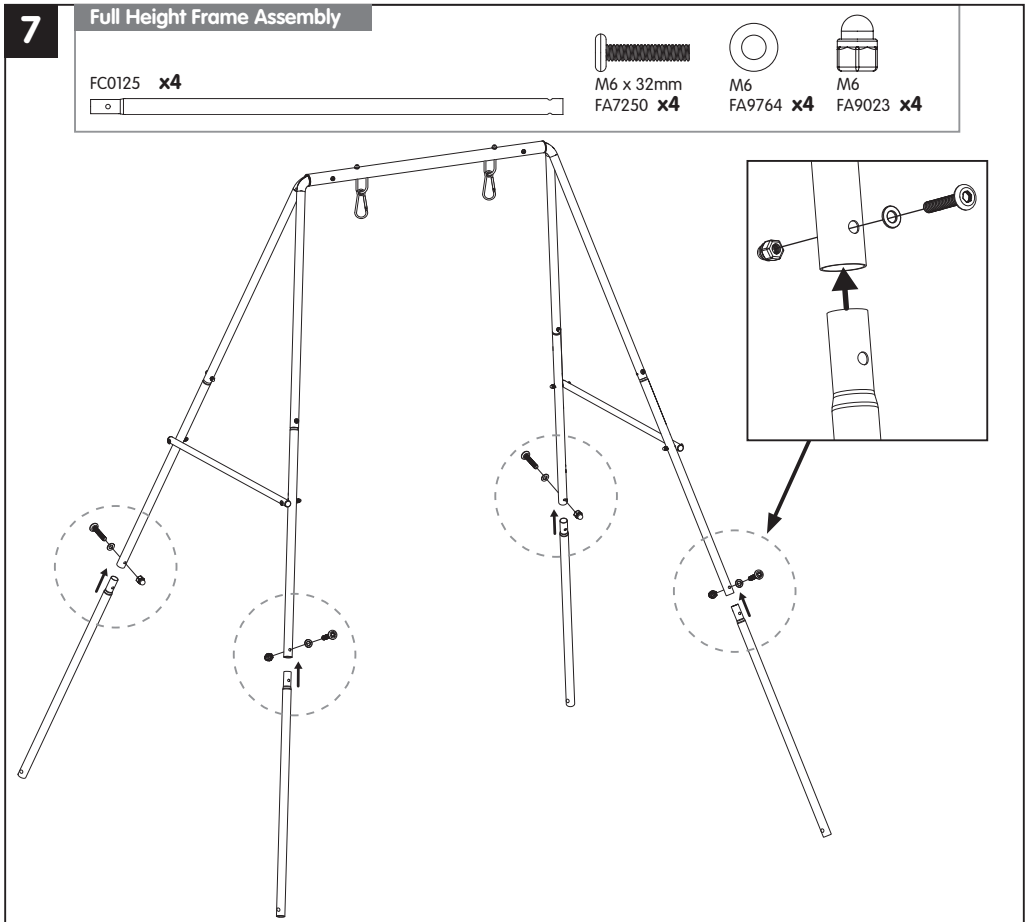
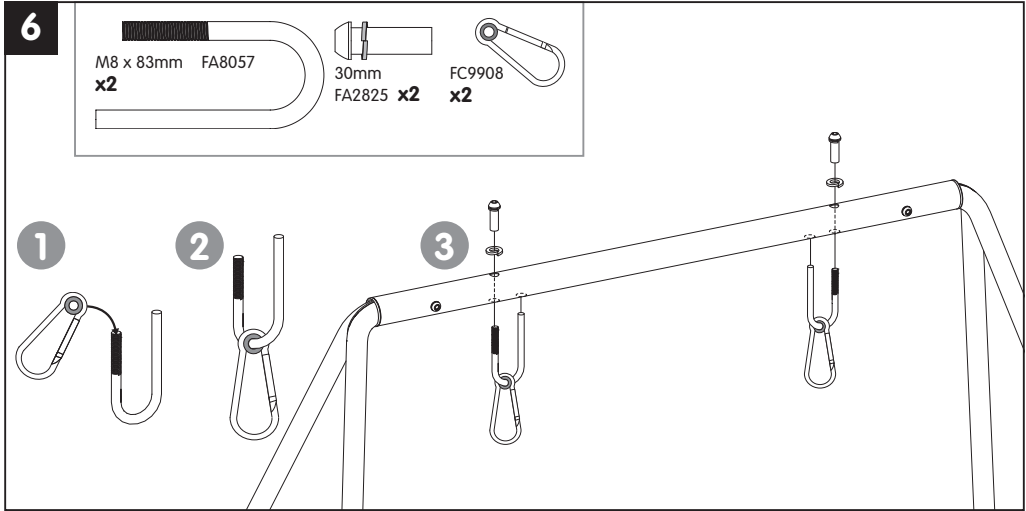

8

Full Height Frame Assembly - Completed

PR9662 x4

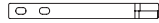

M6 x 32mm  
FA7250 x4



M6  
FA9764 x4



M6  
FA9023 x4

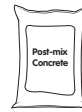

Post mix concrete  
Béton  
Beton  
Hormigón  
Calcestruzzo  
Concrete  
الخرسانة

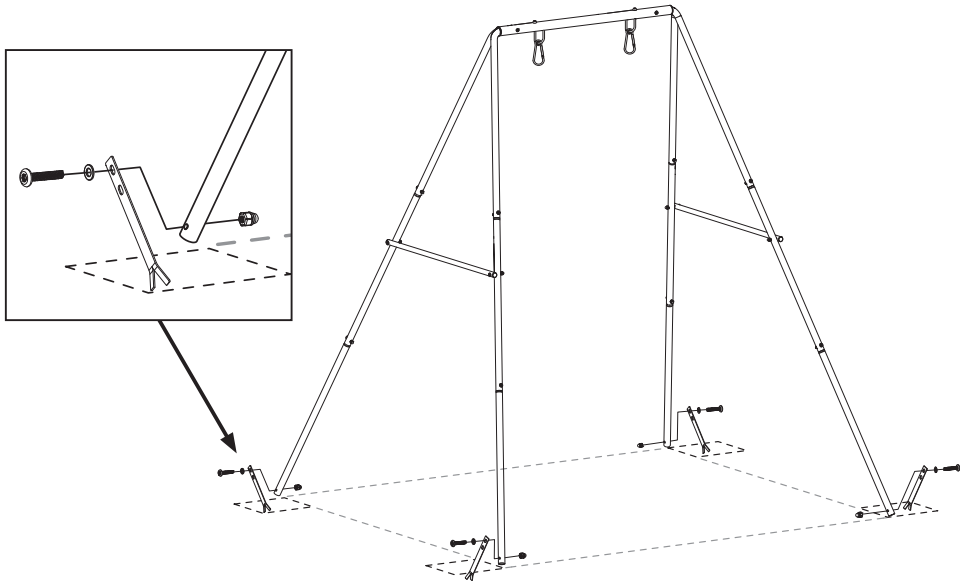
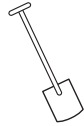

1

x4



2

300mm

300mm

300mm

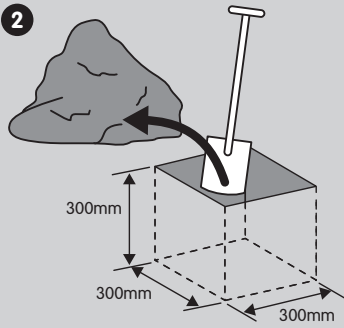

3

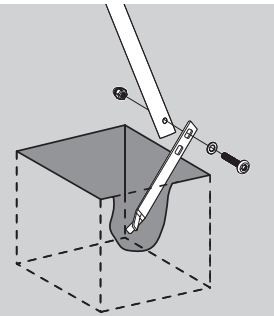

5

Not Supplied.

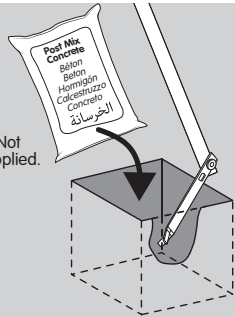

6

x4

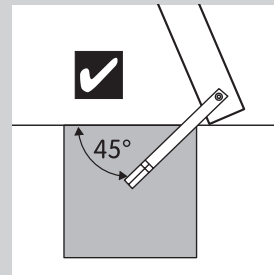
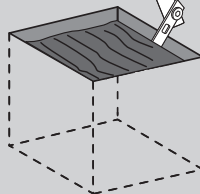

12

TP509 Small to Tall Swing Frame

### TP913 FoldAway Swing Seat

**EN** The TP FoldAway Swing Seat can be used at both low and full height.

Before you use your TP FoldAway Swing Seat please read the safety information carefully and follow its advice at all times.

**FR** Ce siège de balançoire peut être utilisé en position basse ou en position haute.

Avant d'utiliser votre siège de balançoire, veuillez lire attentivement les informations de sécurité et suivre à tout moment les conseils.

**DE** Dieser Schaukelsitz kann bei niedriger und voller Höhe benutzt werden.

Bitte lesen Sie sich vor der Benutzung des Schaukelsitzes sorgfältig die Sicherheitsinformationen durch und befolgen sie die darin enthaltenen Hinweise zu jeder Zeit.

**ES** Este asiento de columpio puede utilizarse tanto con el armazón bajo como alto.

Antes de utilizar el asiento del columpio, lea detenidamente las instrucciones de seguridad y siga sus consejos en todo momento.

**IT** Questo sedile per altalena può essere montato all'altezza massima o a un'altezza più bassa.

Prima di utilizzare il sedile per altalena, leggere attentamente le istruzioni di sicurezza e attenersi sempre a quanto indicato.

**NL** Deze schommel kan zowel op lage als volledige hoogte worden gebruikt.

Lees de veiligheidsinformatie zorgvuldig door voordat u de schommel gebruikt en volg de adviezen te allen tijde op.

**PT** Este assento de balanço pode ser utilizado a meia-altura ou a altura completa.

Antes de utilizar o assento de balanço, leia com atenção as informações de segurança e siga sempre as instruções.

**PL** Siedzisko huśtawki może być używane zarówno w pozycji najniższej, jak i na maksymalnej wysokości.

Przed użyciem siedzenia huśtawki należy dokładnie zapoznać się z informacjami dotyczącymi bezpieczeństwa i zawsze stosować się do zawartych w nich zaleceń.

**AR** يمكن استخدام مقعد التآرجح هذا على ارتفاع منخفض وكامل على حد سواء. قبل استخدام مقعد التآرجح، يرجى قراءة معلومات السلامة بعناية واتبع نصائحها في جميع الأوقات.

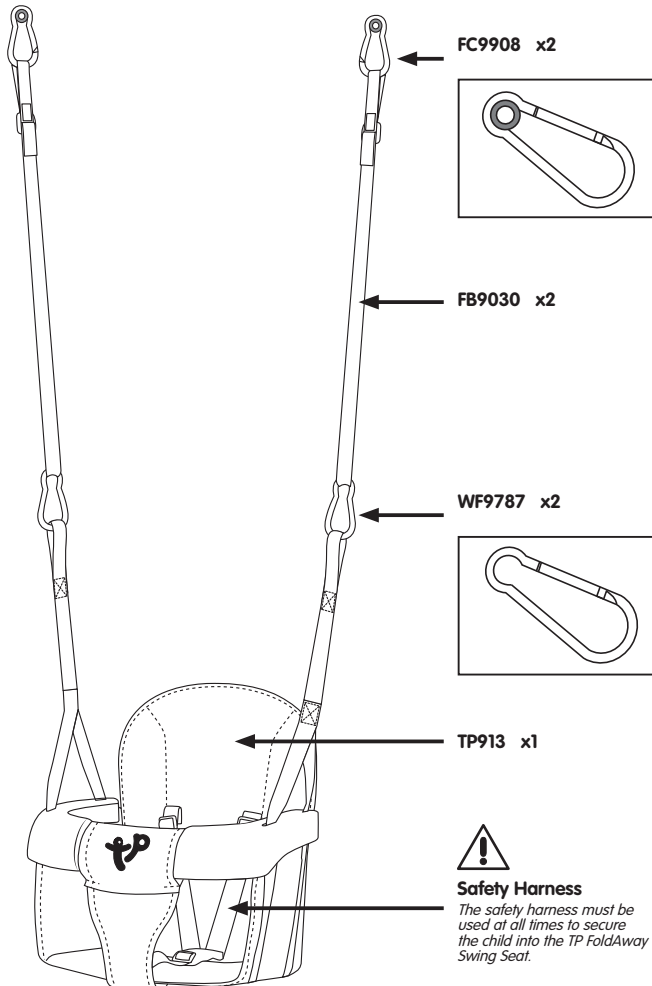



# 11 Attaching your Swing Seat to the frame

## Unfolding the Swing Seat

Déplier le siège de balançoire.  
 Auseinanderfallen des Schaukelsitzes.  
 Para desplegar el asiento del columpio.  
 Come aprire il sedile per altalena.

De schommel uitklappen.  
 Desdobrar o assento de balanço.  
 Rozkładanie siedzenia huśtawki.

حجراتنا ودعم طرب

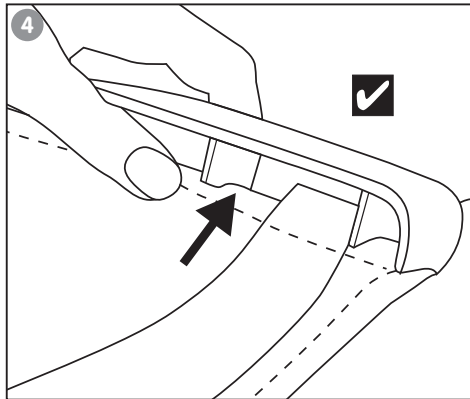
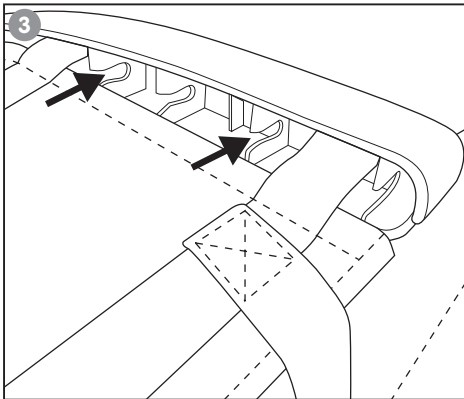
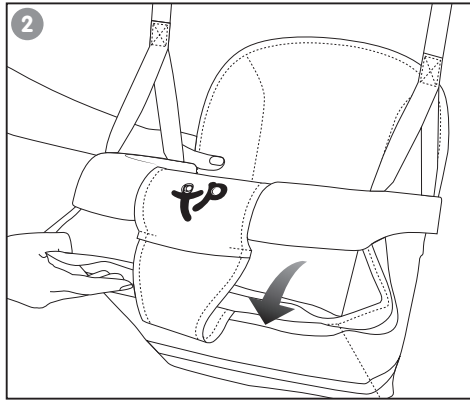
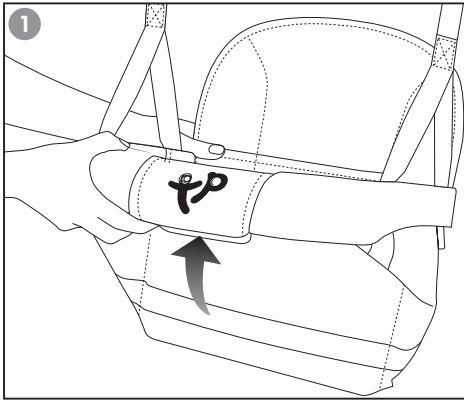

## Folding away the Swing Seat (after use)

Plier le siège de balançoire (après usage).  
 Zusammenfallen des Schaukelsitzes (nach der Benutzung).  
 Para plegar el asiento del columpio (después de usarlo).

Come ripiegare il sedile per altalena (dopo l'uso).  
 De schommel (na gebruik) inklappen.  
 Dobrar o assento de balanço (no final da utilização).  
 Składanie siedzenia huśtawki (po użyciu).

طى بعد التارح (بعد الاستخدام)

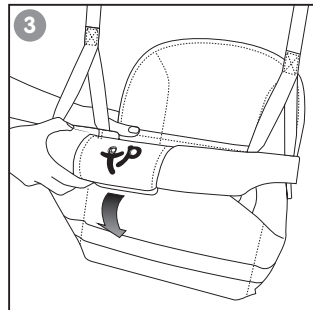
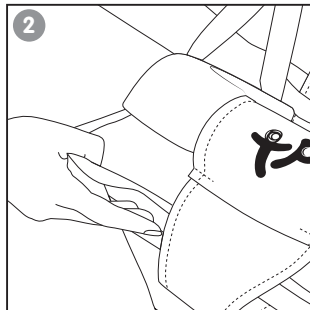
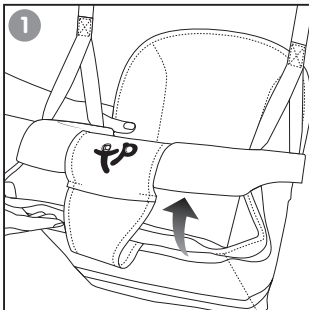

12

Seat assembly to Low Height Frame

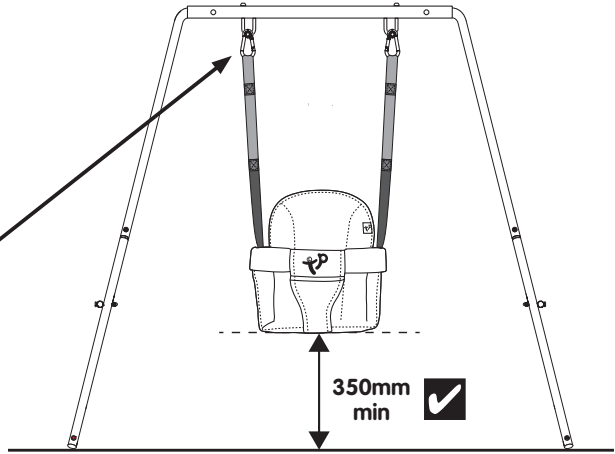
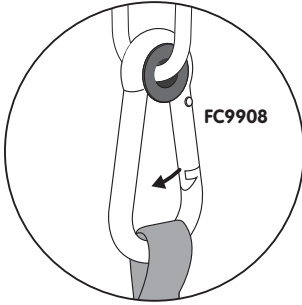
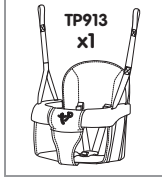

13

Seat assembly to Full Height Frame

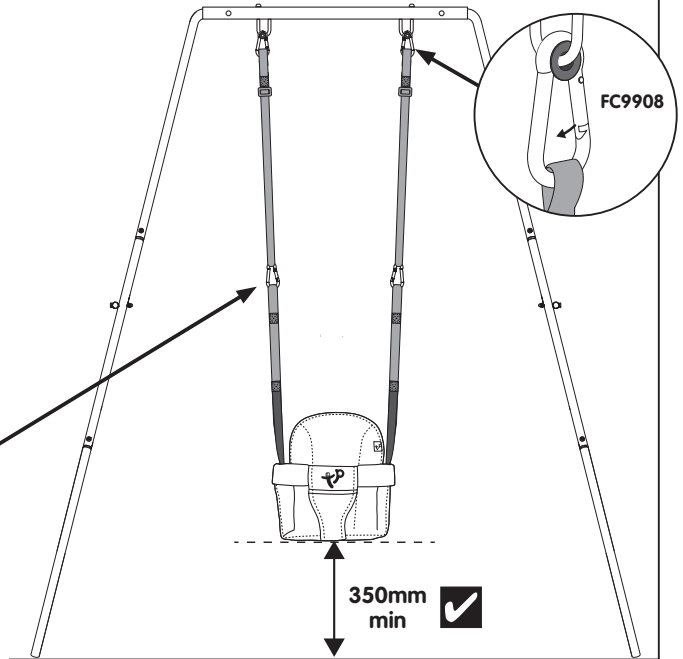
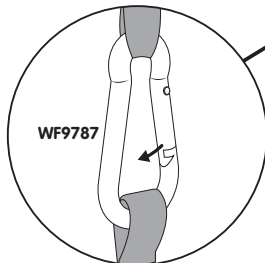
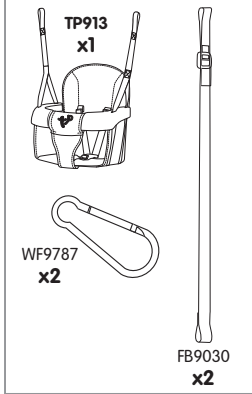

14

Seat assembly to Full Height Frame

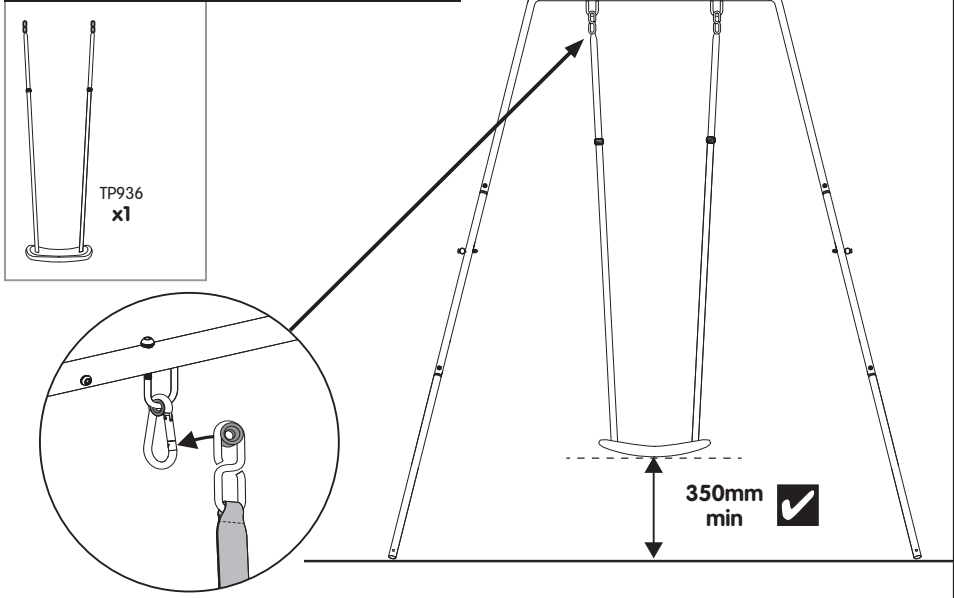

15

How to adjust the height of your Swing Seats

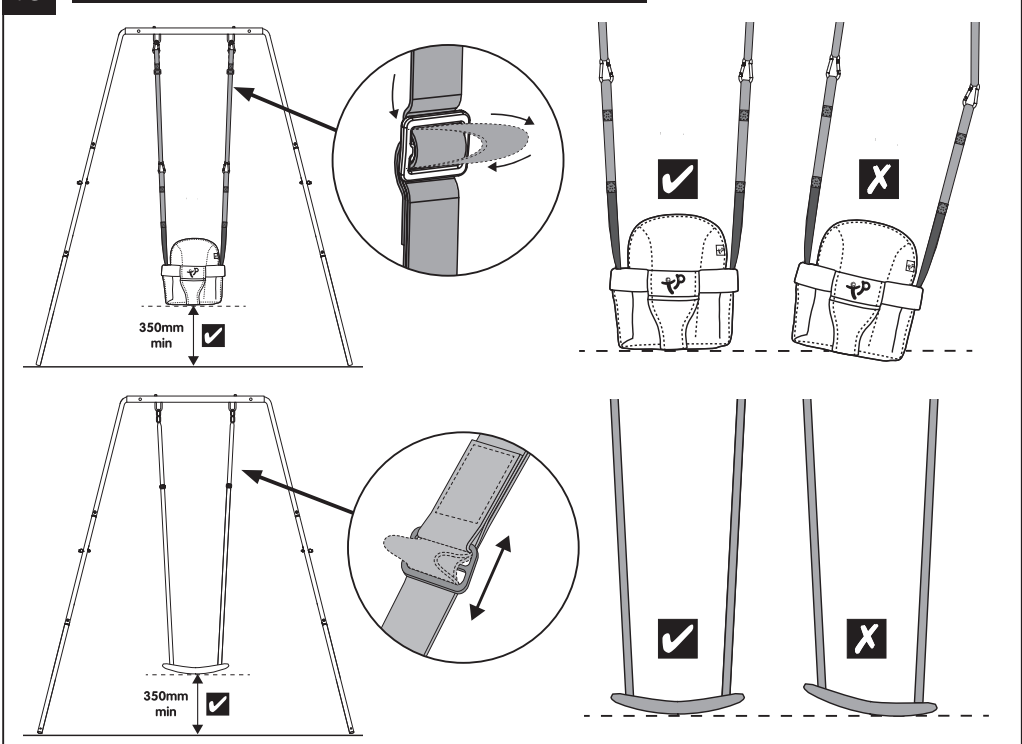

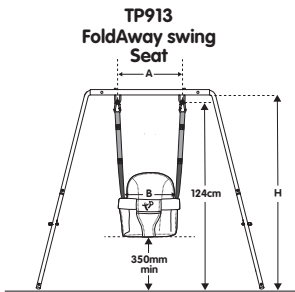

Low Height Swing Frame

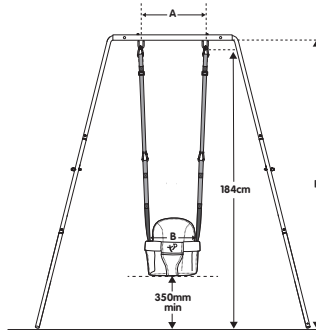

Full Height Swing Frame

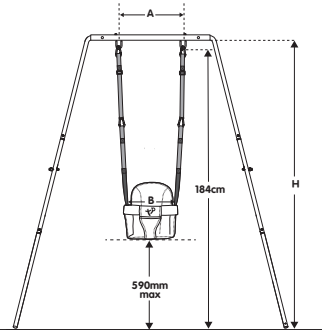

### TP936 Rapide Swing Seat

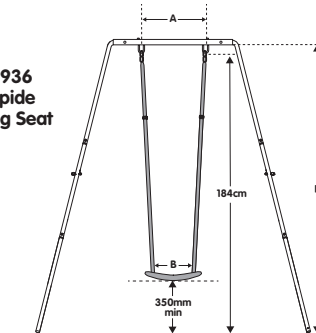

Full Height Swing Frame

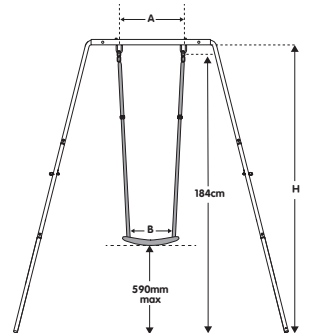

#### EN How to locate your Swing seats correctly on your swing frame.

The maximum height of the swing frame shall not exceed 2500mm.  
The maximum fall height for the swing can be determined by measuring the distance between the pivot points and the ground.

The minimum distance between the suspension points is calculated as follows:  $A = 0,04 h + B$  where

- A is the distance between suspension points along the crossbeam.
- B is the distance between the junction points of the swing element and the means of suspension.
- H is the distance from the ground to the lower side of the crossbeam.

#### FR Comment placer vos sièges de balançoire correctement sur votre structure.

La hauteur maximale du cadre de la balançoire ne devrait pas excéder 2500 mm.  
La hauteur de tombée maximale de la balançoire peut être déterminée en mesurant la distance entre les points pivot et le sol.

La distance minimale entre les points de suspension se calcule de la manière suivante :  $A = 0,04 h + B$  où

- A est la distance entre les points de suspension le long de la traverse
- B est la distance entre les points de jonction de l'élément de la balançoire et les moyens de suspension
- H est la distance entre le sol et le côté le plus bas de la traverse

#### DE Richtiges Positionieren der Schaukelstühle am Schaukelrahmen.

Das Schaukelgestell darf eine maximale Höhe von 2500 mm haben.  
Sie ermitteln die maximale Fallhöhe der Schaukel, indem Sie den Abstand zwischen den Drehpunkten und dem Boden messen.

Der Mindestabstand zwischen den Aufhängepunkten wird wie folgt berechnet:  $A = 0,04 h + B$  Hierbei gilt:

- A ist der Abstand zwischen den Aufhängepunkten am Querbalken.
- B ist der Abstand zwischen den Verbindungspunkten des Schaukelelements und der Aufhängung.
- H ist der Abstand vom Boden bis zur Unterseite des Querbalkens.

#### ES Cómo colocar los asientos correctamente en el armazón del columpio.

La altura del armazón del columpio no debe exceder los 2500 cm como máximo.  
La altura de caída máxima del columpio puede calcularse midiendo la distancia entre los puntos pivotantes y el suelo.

La distancia mínima entre los puntos de suspensión se calcula de la siguiente manera:  $A = 0,04 h + B$ , donde

- A es la distancia entre los puntos de suspensión a lo largo del larguero
- B es la distancia entre los puntos de unión del elemento suspendido (el columpio) y el medio de suspensión
- H es la distancia desde el suelo al lado inferior del larguero

#### PT Como posicionar os assentos de balanço corretamente na estrutura.

A altura máxima da estrutura de balanço não deve ser superior a 2500 mm.  
A altura de queda máxima do balanço pode ser determinada medindo a distância entre os pontos de articulação e o chão.

A distância mínima entre os pontos de suspensão é calculada da seguinte forma:  $A = 0,04 h + B$  em que

- A é a distância entre os pontos de suspensão ao longo da travessa.
- B é a distância entre os pontos de união do elemento de balanço e os meios de suspensão.
- H é a distância do chão até a parte inferior da travessa.

#### IT Come posizionare correttamente i sedili sulla struttura dell'altalena.

L'altezza massima della struttura oscillante non deve essere superiore ai 2500mm.  
L'altezza massima di caduta per l'oscillazione può essere determinata misurando la distanza tra i punti di snodo e il suolo.

La distanza minima tra i punti di sospensione è calcolata come segue:  $A = 0,04 h + B$  dove

- A è la distanza tra i punti di sospensione lungo la traversa
- B è la distanza tra i punti di giunzione dell'elemento oscillante e i mezzi di sospensione
- H è la distanza dal suolo al lato inferiore della traversa

#### PL Jak prawidłowo zamocować siedzenia huśtawki na ramie huśtawki.

Maksymalna wysokość ramy huśtawki nie powinna przekraczać 2500 mm.  
Minimalna odległość między siedzeniem a sąsiednimi strukturami musi wynosić co najmniej 300 mm.  
Maksymalna wysokość upadku może zostać określona przez pomiar odległości między punktem obrotu a podłożem.

Minimalna odległość między punktami zawieszenia obliczana jest następująco:  $A = 0,04 h + B$ , gdzie

- A to odległość między punktami zawieszenia na belce poprzecznej.
- B to odległość między punktami skrzyżowania elementu huśtawki z mocowaniem zawieszenia
- H to odległość od podłoża do niższej części belki poprzecznej.

#### NL Het juist op het schommelframe plaatsen van de schommelzittingen.

De maximale hoogte van het schommelframe mag niet meer bedragen dan 2,5 m.

De minimale ruimte tussen de zitting en omliggende structuren moet minstens 30 cm bedragen.  
De maximale valhoogte voor de schommel kan worden bepaald door de afstand tussen de draaipunten en de grond te meten.

De minimale afstand tussen de ophangpunten wordt als volgt berekend:  $A = 0,04 h + B$  waarbij

- A de afstand tussen de ophangpunten over een dwarsbalk
- B de afstand tussen de knooppunten van het schommel-element en de wijze van ophanging
- H de afstand van de grond tot de onderkant van de dwarsbalk

#### AR كيفية وضع مقاعد التلّحج بشكل صحيح على إطار التلّحج الحاصي بك

لا يجوز أن يتجاوز الارتفاع الأقصى لإطار الأجرعة 2500 ملم.  
يمكن تحديد ارتفاع السقوط الأقصى للأجرعة عن طريق قياس المسافة بين نقاط الدوران والأرض.

تحتسب المسافة الدنيا بين نقاط التعليق كالآتي:  $A = 0,04 h + B$  حيث

- A هي المسافة بين نقاط التعليق على العارضة المتقاطعة
- B هي المسافة بين نقاط التقاطع لبعض الأجرعة ووسيلة التعليق
- R هي المسافة من الأرض إلى الجانب الأسفل من العارضة المتقاطعة

# 17

## Care and Maintenance of your Swing Seat

- EN** **Care and Maintenance of your swing Seat**  
The TP Folding swing seat is designed with maximum comfort for your child. Due to the soft materials, we do not recommend leaving it outside for long periods. Please look after it by taking it inside when not in use.
- FR** **Entretien et maintenance de votre siège de balançoire**  
Le siège de balançoire pliant TP est conçu pour garantir un maximum de confort à votre enfant. Fabriqué en matériaux doux, ce siège ne devrait pas être laissé dehors pendant une période prolongée. Prendre soin de ce produit en le plaçant à l'intérieur lorsqu'il n'est pas utilisé.
- DE** **Pflege und Instandhaltung Ihres Schaukelsitzes**  
Der zusammenfaltbare TP-Schaukelsitz bietet Ihrem Kind den maximalen Komfort. Aufgrund der weichen Materialien sollte er nicht für längere Zeit draußen bleiben. Schonen Sie ihn und nehmen Sie ihn bei Nichtgebrauch mit ins Haus.
- ES** **Cuidado y mantenimiento del asiento del columpio**  
El asiento plegable para columpio de TP ha sido diseñado pensando en el máximo confort de su hijo. Al estar hecho de materiales blandos, no recomendamos dejarlo en el exterior durante periodos prolongados. Cuidelo bien guardándolo en el interior cuando no se vaya a utilizar.
- IT** **Cura e manutenzione del sedile per altalena**  
Il sedile pieghevole per altalena di TP è pensato per il massimo comfort del bambino. Data la natura dei materiali di cui è composto, non raccomandiamo di lasciarlo all'aperto per lunghi periodi. Per mantenerlo in buone condizioni, riparlo in un luogo chiuso quando non in uso.

- NL** **Zorg voor en onderhoud van de schommel**  
De inklapbare schommelzitting van TP is gemaakt voor maximaal comfort voor uw kind. Door de zachte materialen wordt het niet aanbevolen de schommelzitting gedurende langere tijd buiten te laten liggen. Zorg ervoor dat de schommelzitting binnen wordt bewaard wanneer deze niet wordt gebruikt.
- PT** **Cuidados e manutenção a ter com o assento de balanço**  
O assento de balanço dobrável da TP foi concebido para proporcionar o máximo conforto à criança. Devido aos materiais macios, não recomendamos que este produto seja deixado no exterior durante longos períodos de tempo. Tenha o cuidado de o guardar num espaço interior quando não estiver a ser utilizado.
- PL** **Konserwacja i czyszczenie siedzenia huśtawki**  
Składane siedzenie huśtawki firmy TP zostało zaprojektowane z myślą o maksymalnym komforcie Twojego dziecka. Ze względu na miękkie materiały zastosowane w tym produkcie nie zaleca się pozostawiania go na zewnątrz zbyt długo. Prosimy składać i zabierać huśtawkę do środka, gdy nie jest używana.
- AR** **العناية بمقعد التآرجح لديك وصيانته**  
تم تصميم مقعد التآرجح TP القابل للطي مع ضمان الراحة القصوى لطفلك. ولأنه مصنوع من مواد ناعمة لا توصي بتركه في الخارج لفترات طويلة. يرجى الاعتناء به بوضعه في الداخل في حالة عدم استخدامه.

# 18

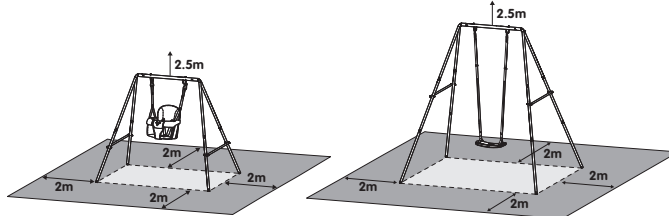

- EN** The safe play area refers to the zone extending 200cm around the toys on all sides and 250 cm above the toy. The safe play area must be free from all obstacles.
- FR** L'espace de sécurité se rapporte à la zone de 200 cm qui s'étend de tous les côtés autour des jeux et à la zone de 250 cm qui s'étend au-dessus du jeu. L'espace de sécurité doit être libre.
- DE** Der sichere Spielbereich bezieht sich auf eine Zone von 200 cm rund um das Spielzeug sowie 250 cm oberhalb des Spielzeugs. Der sichere Spielbereich muss frei von allen Hindernissen sein.
- ES** El término zona segura de juego hace referencia a la zona que abarca un radio de 200 cm en torno al juguete y 250 cm por encima del juguete. La zona segura de juego debe estar despejada y libre de todo obstáculo.
- IT** L'area di gioco sicura si riferisce alla zona che si estende per 200 cm su tutti i lati attorno all'insieme da gioco e per 250 cm sopra l'apparato. L'area di gioco sicura deve essere priva di ostacoli.
- NL** Het veilige speelgebied betreft de zone die zich 2 meter aan alle zijden rond de speelobjecten bevindt en 2,5 meter boven het speelobject. Het veilige speelgebied moet vrij zijn van enig obstakel.
- PT** A área de segurança refere-se à zona que se estende 200 cm para todos os lados para além do brinquedo e 250 cm acima do brinquedo. A área livre não deve conter qualquer obstáculo.
- PL** Wolna przestrzeń bezpiecznej zabawy to strefa 200 cm wokół zabawki oraz 250 cm nad zabawką. W wolnej przestrzeni bezpiecznej zabawy nie powinno być żadnych przeszkód.
- AR** تشير منطقة اللعب الآمن إلى المنطقة التي تمتد 200 سم حول الألعاب من جميع الجوانب و250 سم فوق الألعاب. يجب أن تكون منطقة اللعب الآمن خالية من أي عوائق.

# 19

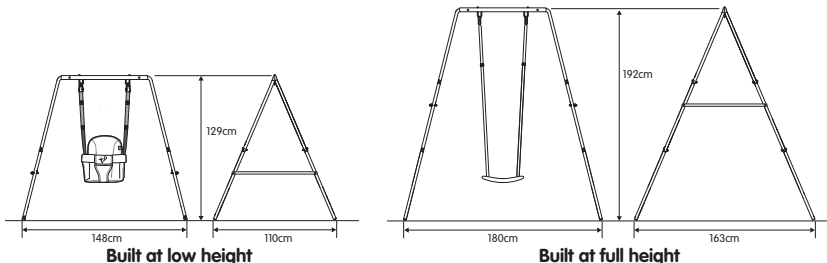



## Thank you

Thank you for purchasing this product.

Please register your new product on line at [tptoys.com](http://tptoys.com)

[www.tptoys.com/customer/productregistration](http://www.tptoys.com/customer/productregistration)

Find out about the guarantee for this product,

visit [www.tptoys.com/customer/pages/guaranteeinformation](http://www.tptoys.com/customer/pages/guaranteeinformation)

For customer services and help with your product,

visit [www.tptoys.com/customer/help](http://www.tptoys.com/customer/help)

- EN** *Robovision Ltd /a TP Toys protects their unique designs worldwide with patents and design registrations. For full information on the intellectual property relating to TP products please visit [www.tptoys.com/intellectualproperty](http://www.tptoys.com/intellectualproperty)*
- FR** *Robovision Ltd protège ses designs uniques au monde avec des marques, brevets et dépôts de dessins. Pour plus d'informations concernant la propriété intellectuelle de Robovision, veuillez vous rendre sur [www.tptoys.com/intellectualproperty](http://www.tptoys.com/intellectualproperty)*
- IT** *Robovision Ltd tutela i propri progetti e modelli esclusivi a livello mondiale attraverso la registrazioni di marchi, brevetti e disegni industriali. Per informazioni complete relative alla proprietà intellettuale Robovision consultare [www.tptoys.com/intellectualproperty](http://www.tptoys.com/intellectualproperty)*
- ES** *Robovision Ltd protege sus diseños exclusivos mediante marcas registradas, patentes, y el registro de dibujos y modelos. Para ampliar información sobre la propiedad intelectual de Robovision vaya a [www.tptoys.com/intellectualproperty](http://www.tptoys.com/intellectualproperty)*
- DE** *Robovision Ltd schützt seine einzigartigen Designs weltweit durch Markenzeichen, Patente und Design-Eintragungen. Umfassende Informationen über das geistige Eigentum von Robovision finden Sie unter [www.tptoys.com/intellectualproperty](http://www.tptoys.com/intellectualproperty)*
- NL** *Robovision Ltd beschermt hun unieke ontwerpen wereldwijd met octrooien, handelsmerken en het registreren van ontwerpen. Voor meer informatie over het intellectueel eigendom van Robovision Ltd gaat u naar [www.tptoys.com/intellectualproperty](http://www.tptoys.com/intellectualproperty)*
- PT** *Os designs exclusivos da Robovision Ltd estão protegidos por marcas registadas, patentes e registos de design. Para mais informações relativas à propriedade intelectual da Robovision, consulte [www.tptoys.com/intellectualproperty](http://www.tptoys.com/intellectualproperty)*
- PL** *Spółka Robovision Ltd chroni swoje unikatowe wzornictwo na całym świecie przez patenty, znaki towarowe i rejestrację wzorów. Więcej informacji o prawach własności intelektualnej spółki Robovision Ltd można znaleźć na [www.tptoys.com/intellectualproperty](http://www.tptoys.com/intellectualproperty)*

تقوم شركة (Robovision Ltd) بحماية تصاميمها الفريدة على مستوى العالم بتسجيل العلامات التجارية، وبراءات الاختراع، والتصاميم. للاطلاع على المعلومات الكاملة المتعلقة بالملكية الفكرية التابعة لشركة (Robovision) يرجى مراجعة [www.tptoys.com/intellectualproperty](http://www.tptoys.com/intellectualproperty) **AR**

### Your TP Guarantee Number/Product Batch No is