

# Assembly Instructions

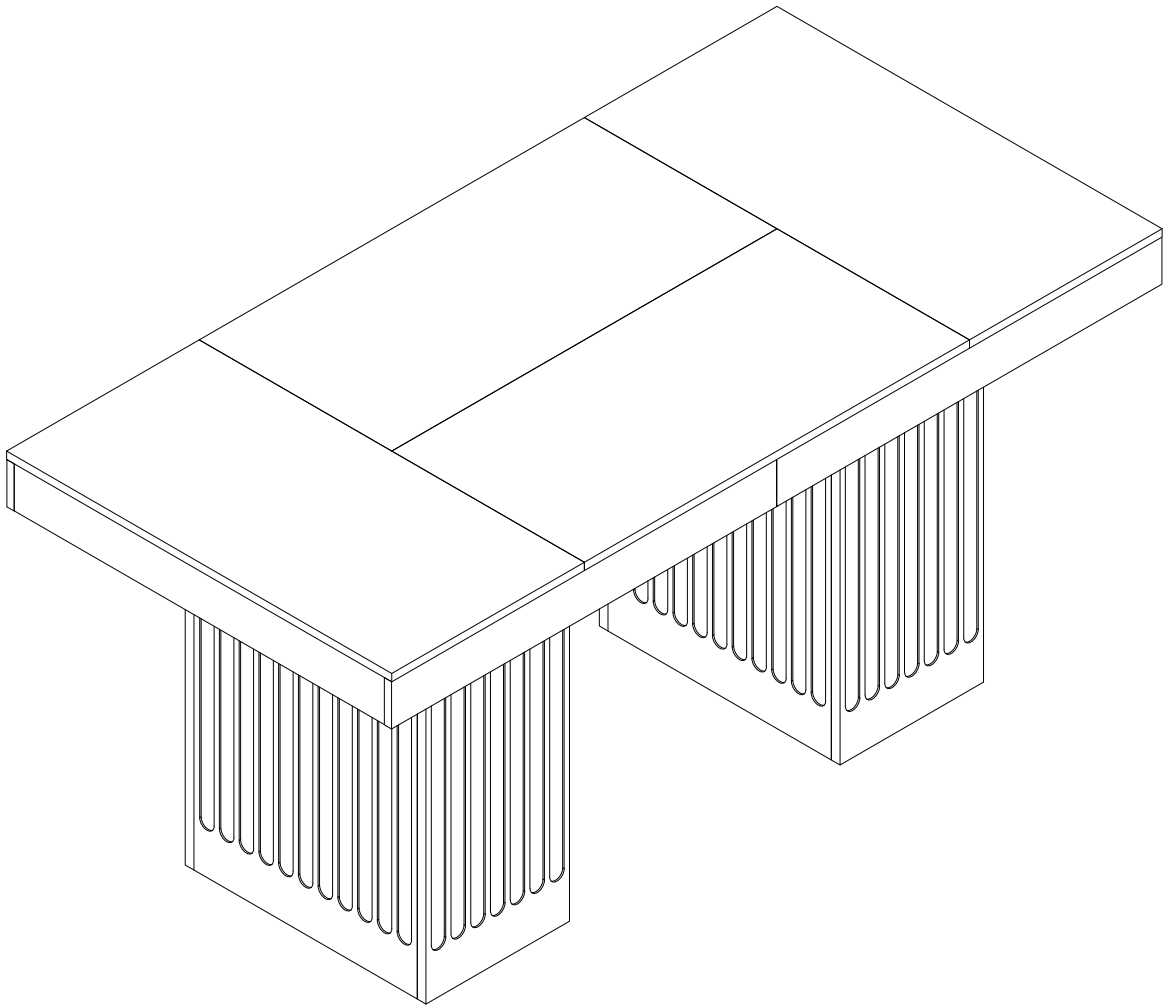

---

**Rectangular Table**

Model No.  
**HOGA-F2381**

---

# Contact Us

## We're here to help you.



Your satisfaction is our top priority. If you encounter any issues with this product, such as missing or damaged parts, we're here to help. Please retain the original packaging and take photos of the packaging and the product, then contact us as soon as possible.

### Warm Tips

1. Carefully read these instructions and keep them for future reference.
2. Check the parts list and confirm everything's there before starting assembly.
3. When assembling, put all parts on a soft, smooth surface like a carpet to avoid scratches.
4. Don't fully tighten screws until all parts are confirmed in place to avoid misalignment.

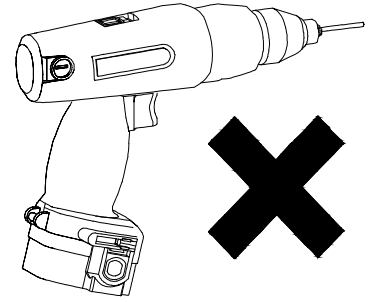
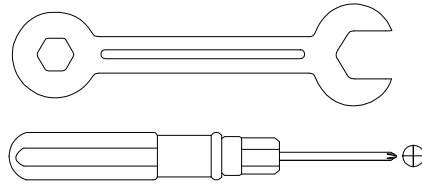
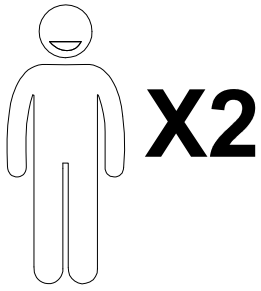

We recommend using hand tools for assembly.

If an electric screwdriver is used, reduce power and torque to avoid damage to the product.

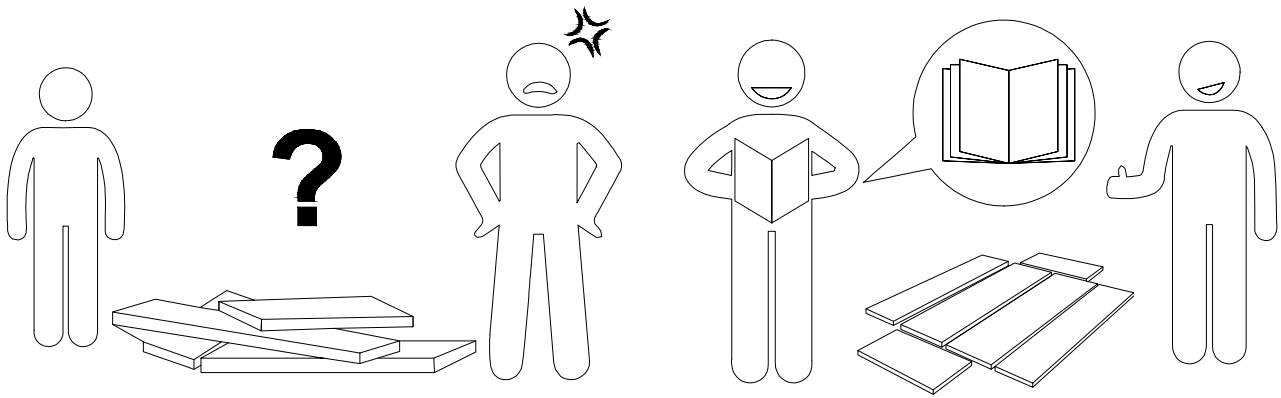

## AVOID SCRATCHES

In order to avoid scratching, this furniture should be assembled on a soft surface, such as a rug.

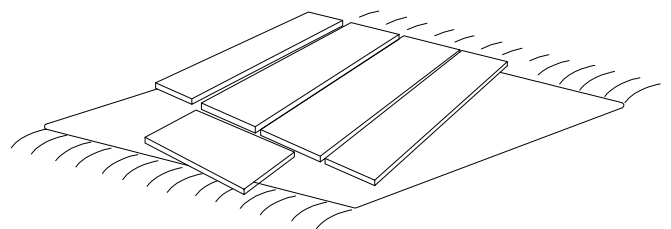
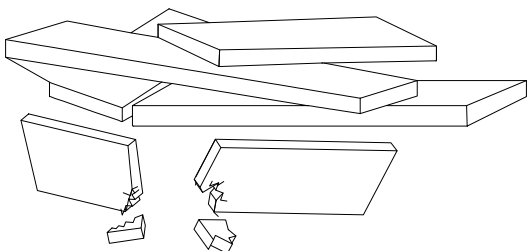

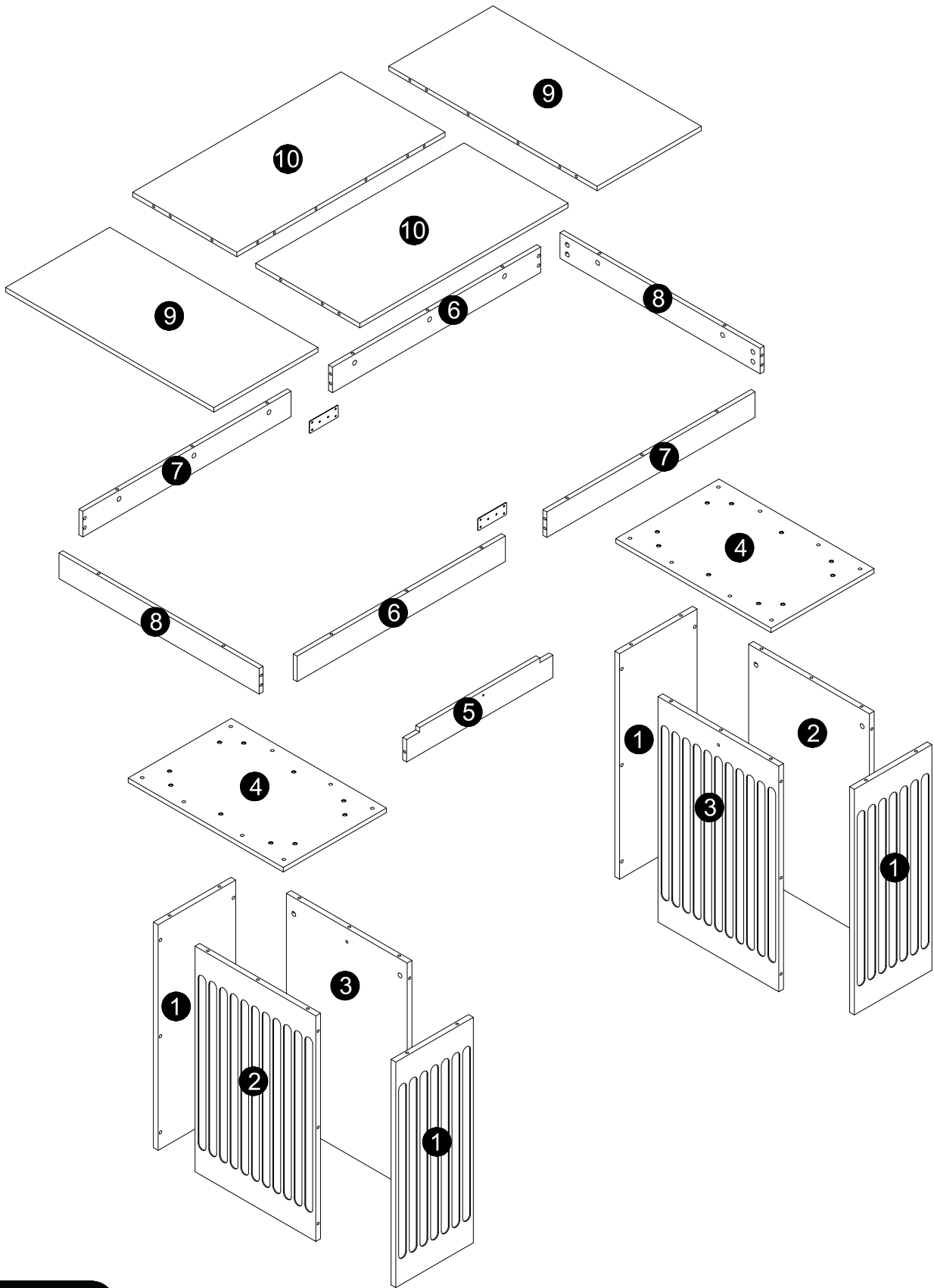



 **Caution**

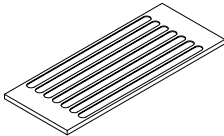
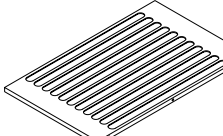
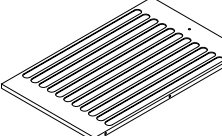
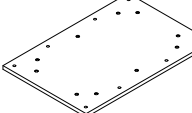
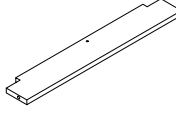
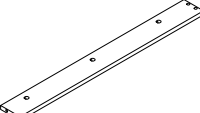
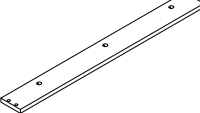
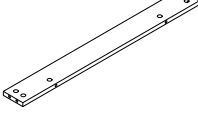
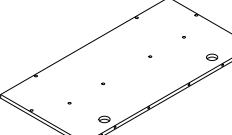
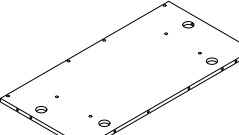

Make sure all parts are included. Most board parts are labeled or stamped on the raw edge. Contact us for a free replacement if you encounter any damaged or missing parts.

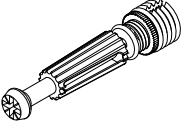
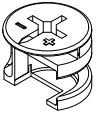
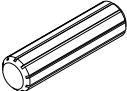

# Parts List

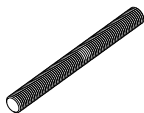
<p>①</p>  <p>4 pcs</p>	<p>②</p>  <p>2pcs</p>	<p>③</p>  <p>2pcs</p>	<p>④</p>  <p>2pcs</p>	<p>⑤</p>  <p>1 pc</p>
<p>⑥</p>  <p>2 pcs</p>	<p>⑦</p>  <p>2 pcs</p>	<p>⑧</p>  <p>2 pcs</p>	<p>⑨</p>  <p>2 pcs</p>	<p>⑩</p>  <p>2 pcs</p>

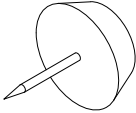
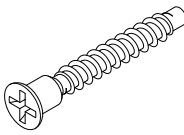
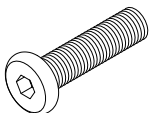
# Hardware List

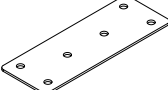
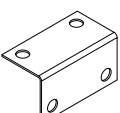
A	B	C	D		E
			D1	D2	
					
M6x35mm	Ø15x12mm	Ø8x30mm		M6	Ø6x95mm
48 pcs	48 pcs	16 pcs	12 pcs	12 pcs	6 pcs

F	G	H	I	J	K
					
	Ø7x38mm	M6x25mm	Ø3.5x14mm		20x20mm
12 pcs	22 pcs	16 pcs	16 pcs	2 pcs	1 pc

L					
					
M6		M4			
2 pcs	1 pc	1 pc			

## Installation of Cams and Pins



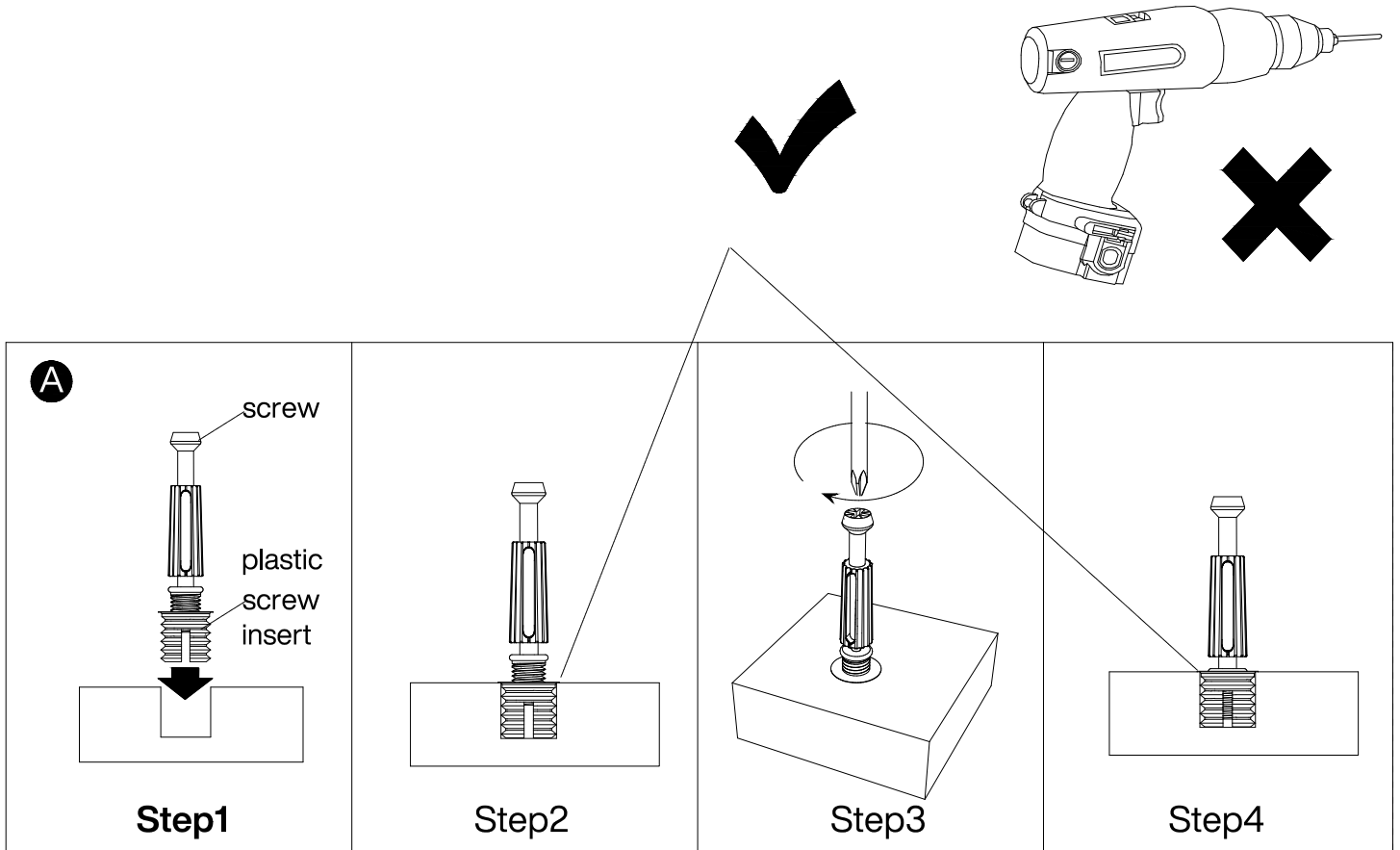

Step 1-2: Align the plastic part with the mounting hole and press it in. If you can't press it in, loosen the screw counter clockwise or completely remove the screw from the plastic part and try again.  
Step 3-4: After pressing the plastic part into place, use a screwdriver to tighten the screw clockwise.

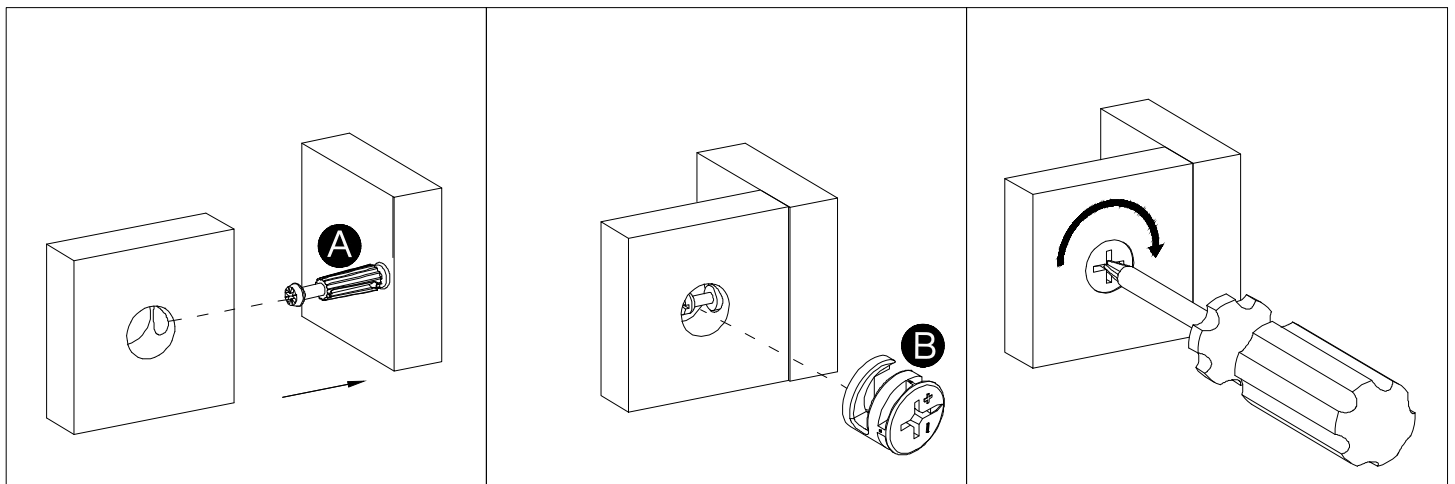

Screw the pin into the hole. Set the cams correctly by aligning the head of the cams with the lock pins. Lock the cam by turning the cam head with a screwdriver until it is tightened. Please do not use an electric screwdriver to assemble the unit.

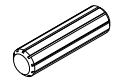



# 1

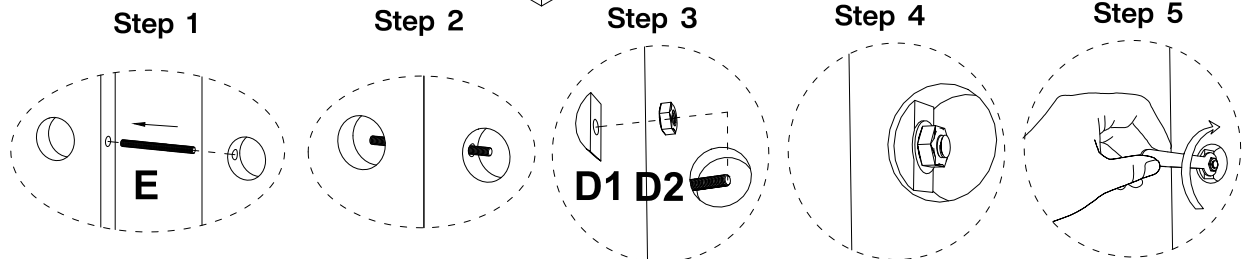
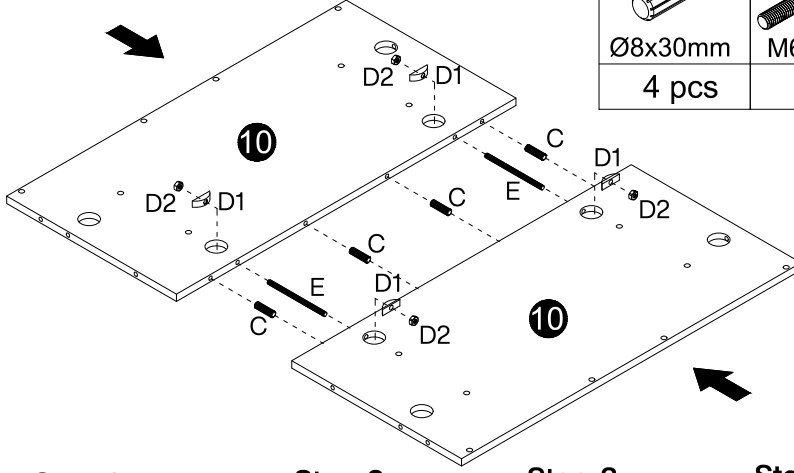

C	E	D1	D2
			
∅8x30mm	M6x95mm		M6
4 pcs	2 pcs	4 pcs	4 pcs

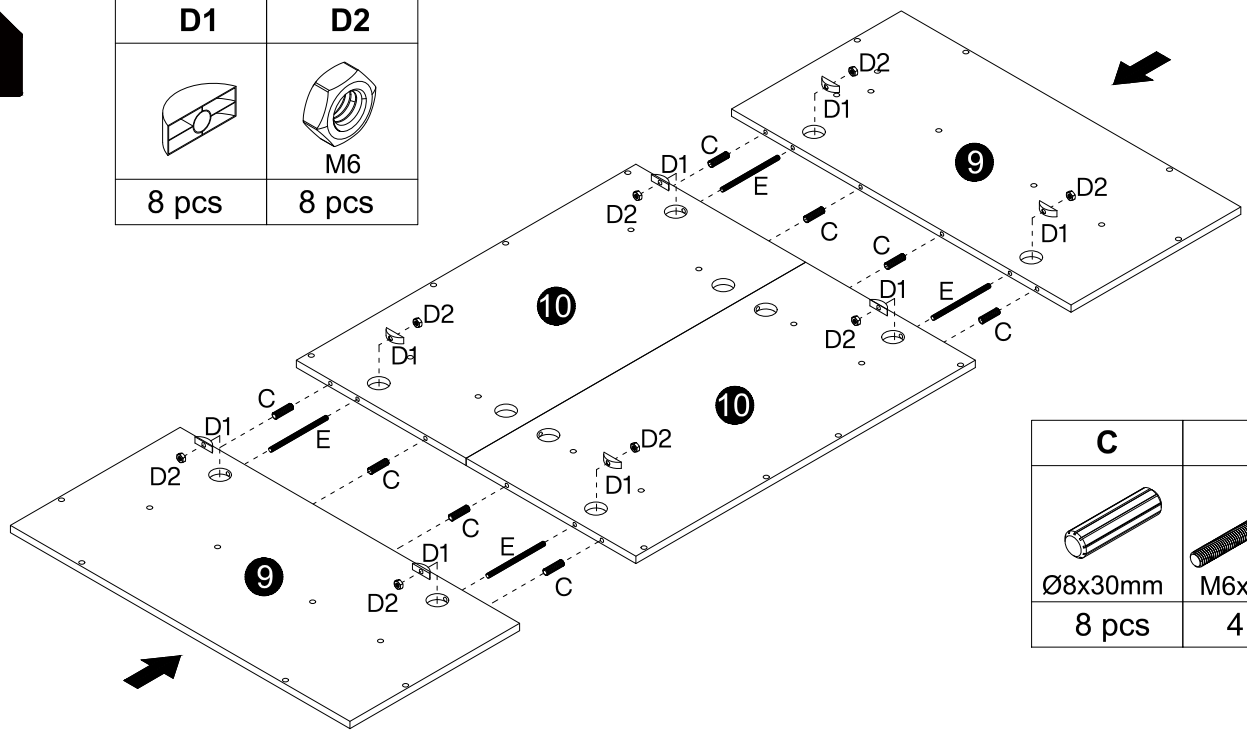

# 2

D1	D2
	
	M6
8 pcs	8 pcs

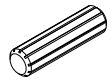

C	E
	
∅8x30mm	M6x95mm
8 pcs	4 pcs

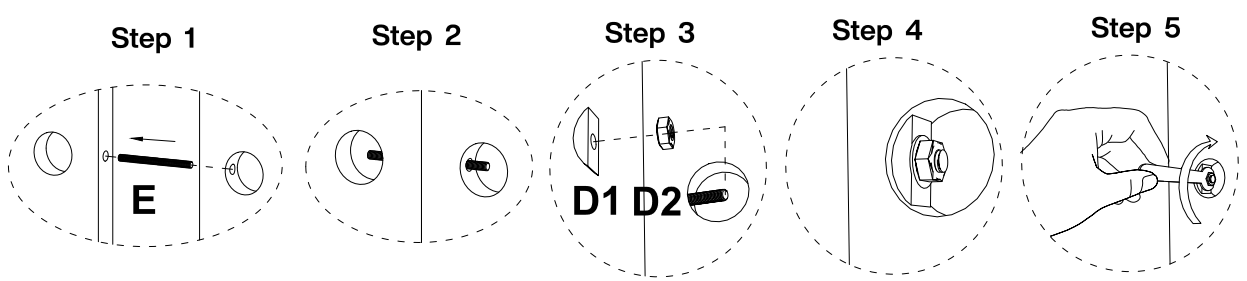

3

C

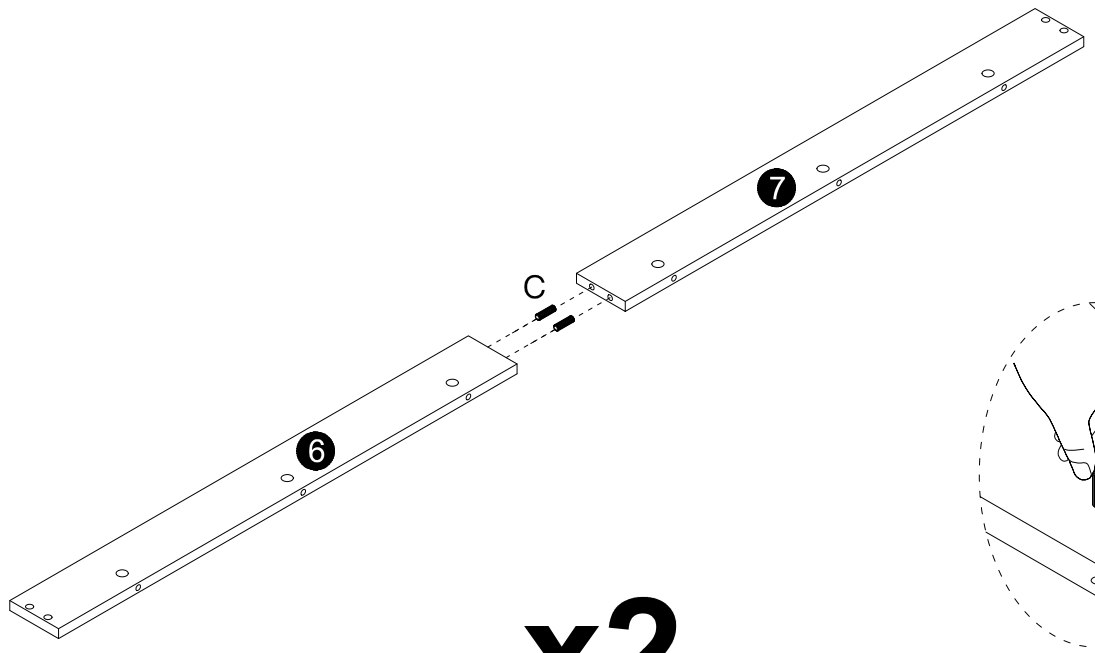
Ø8x30mm
4 pcs

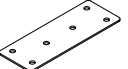

x2

4

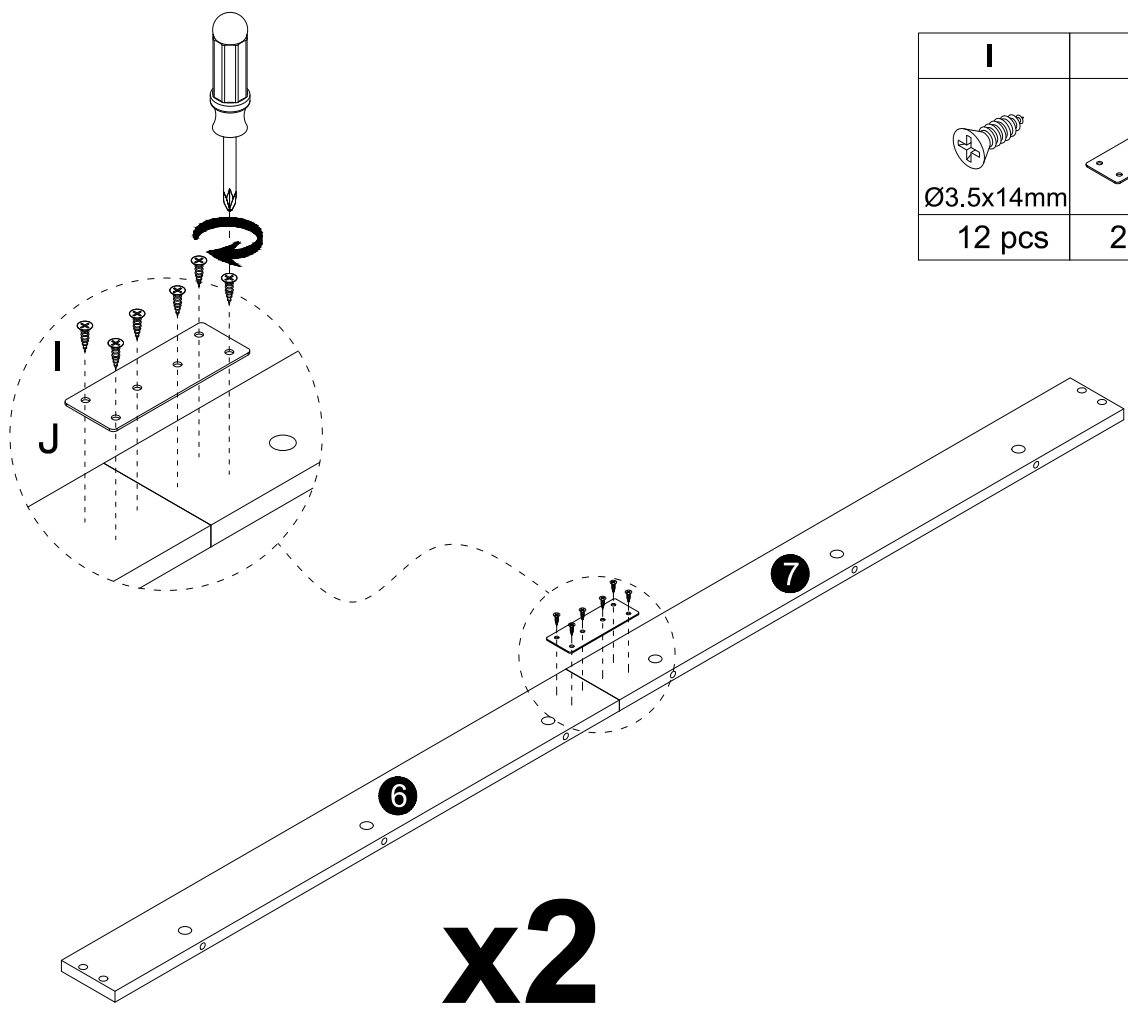
I	J
	
Ø3.5x14mm	
12 pcs	2 pcs



x2

5

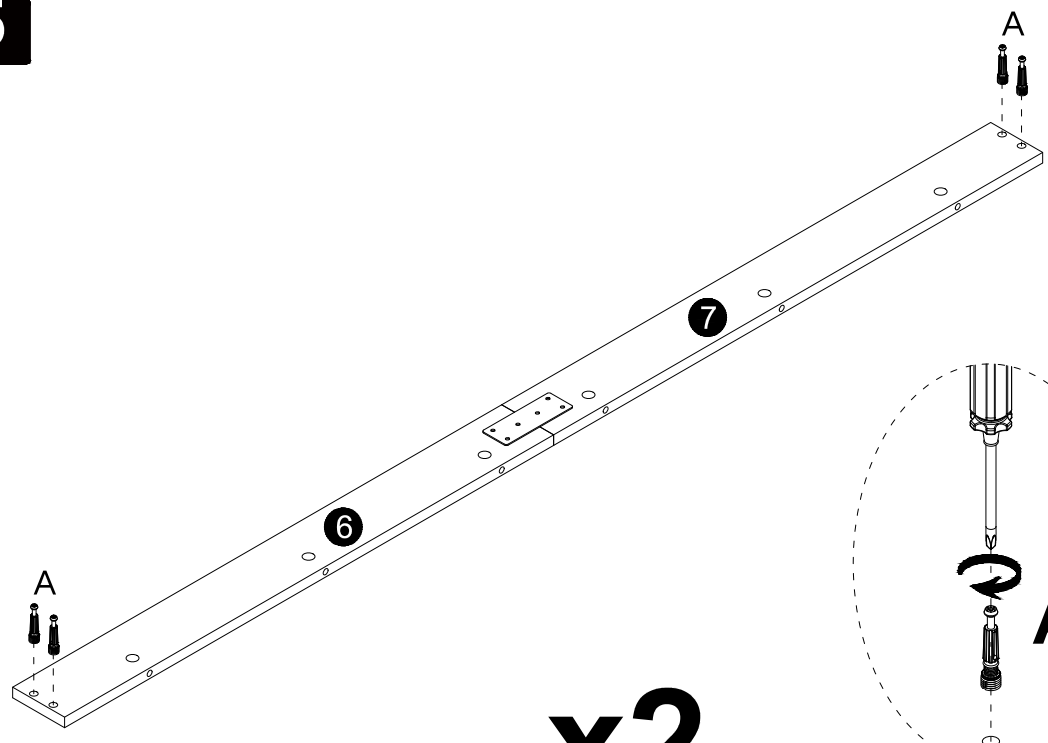

x2

<b>A</b>

M6x35mm
8pcs

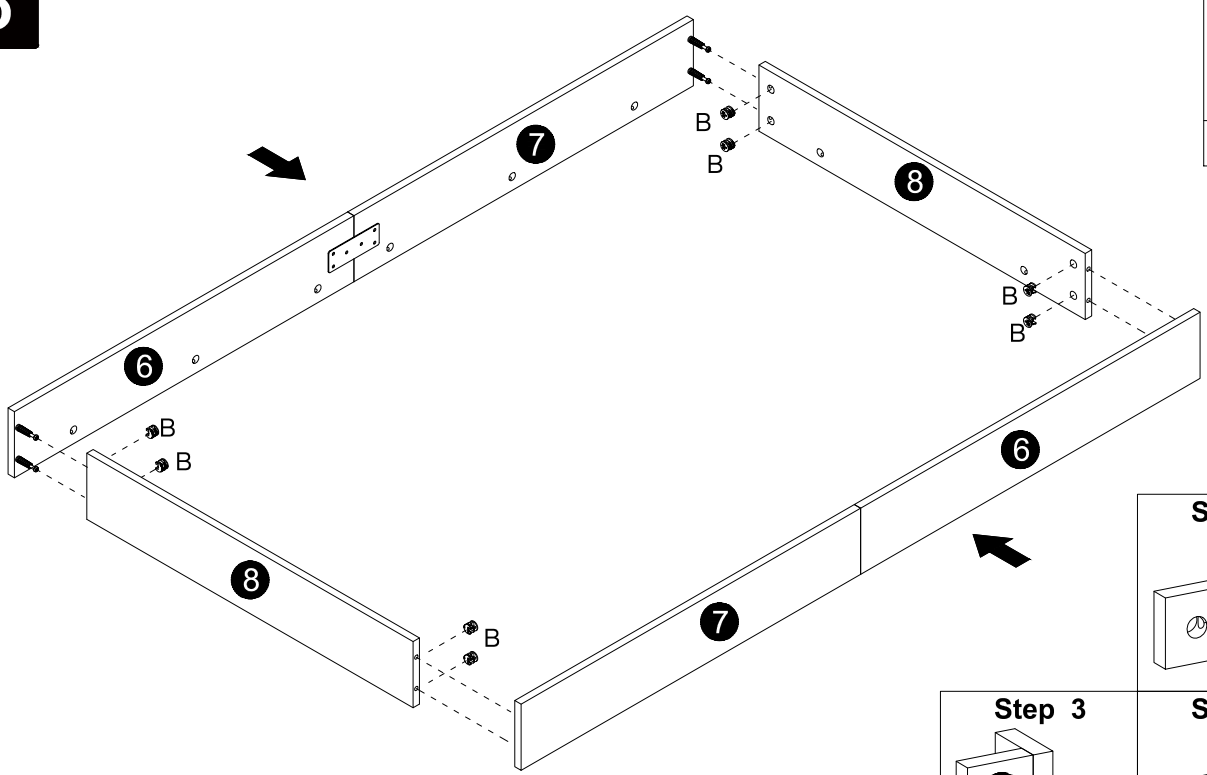
6

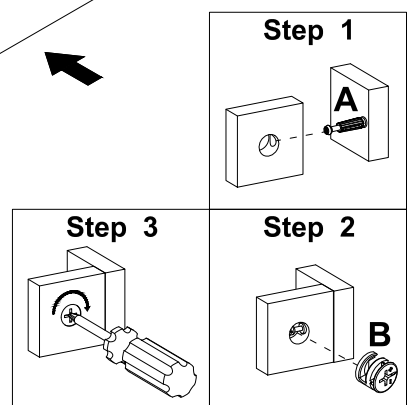

<b>B</b>

8 pcs

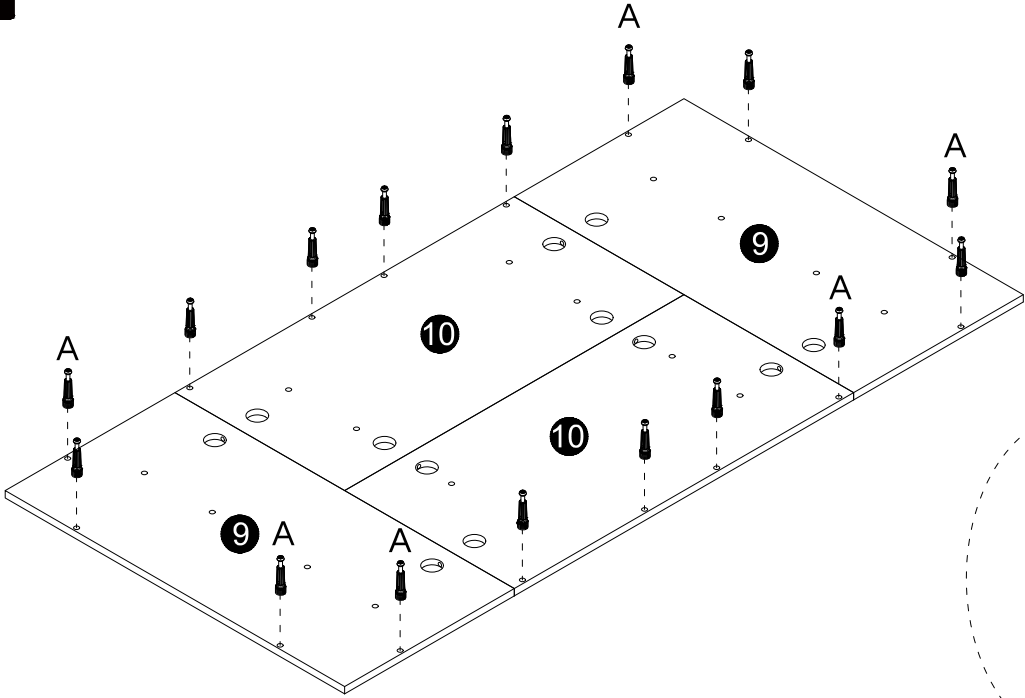

7

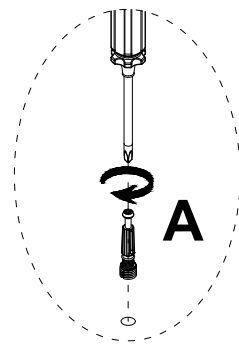

<b>A</b>

M6x35mm
16 pcs

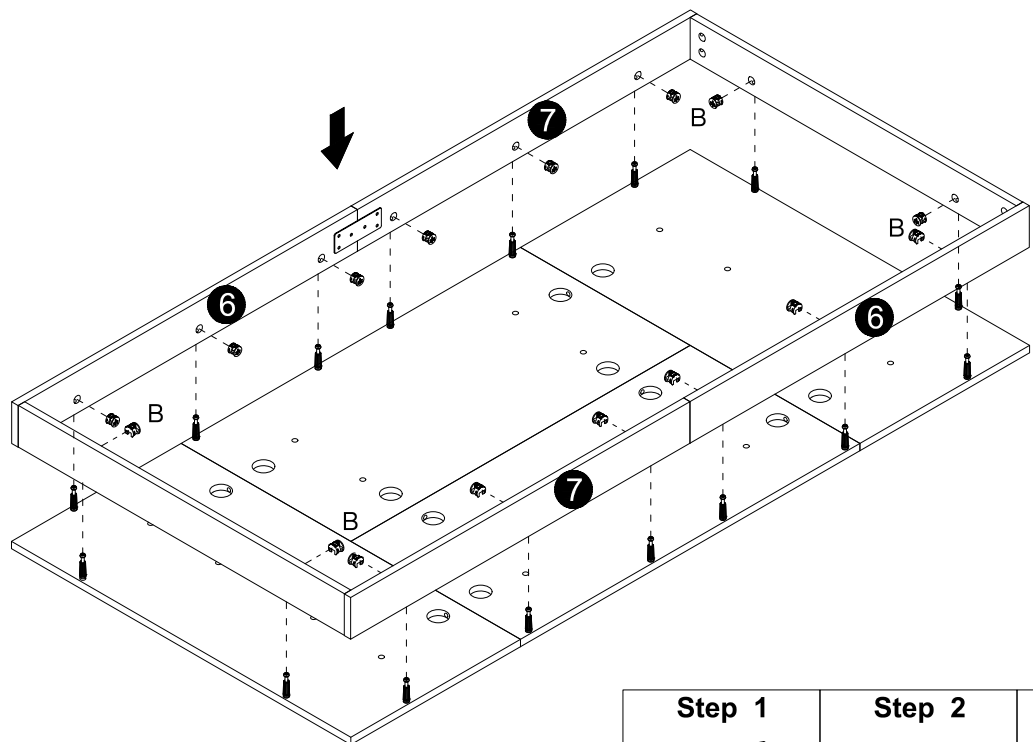

8

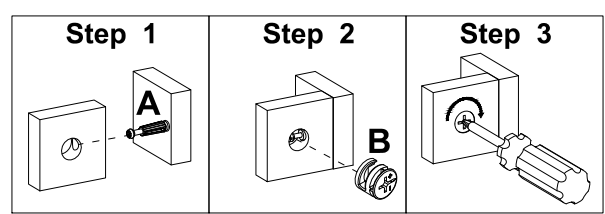

<b>B</b>

16 pcs

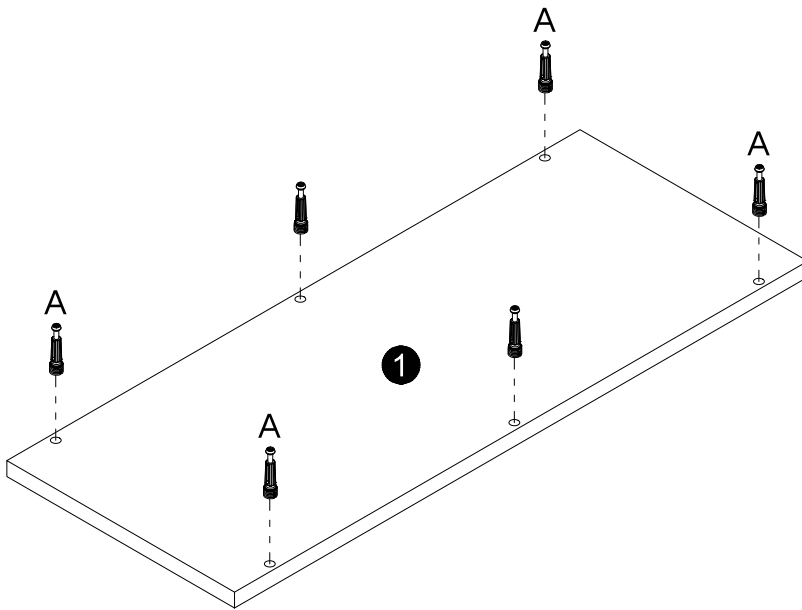

9



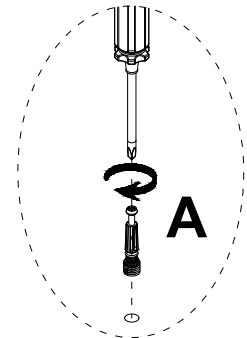

<b>A</b>

M6x35mm
24 pcs

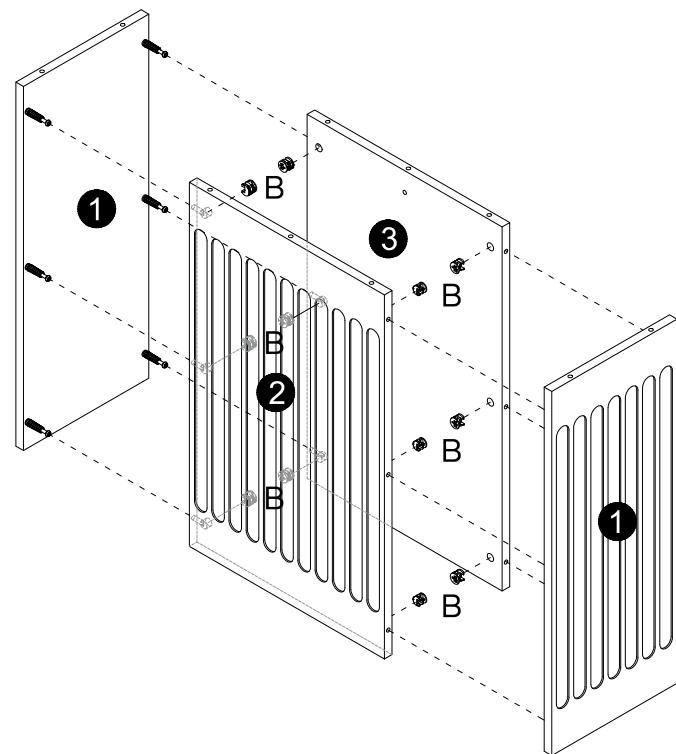
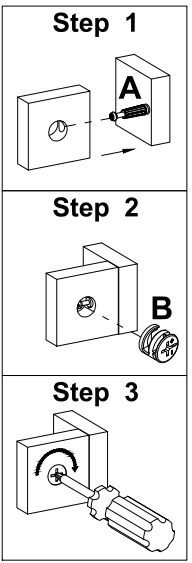

x4

10



<b>B</b>

24 pcs

x2

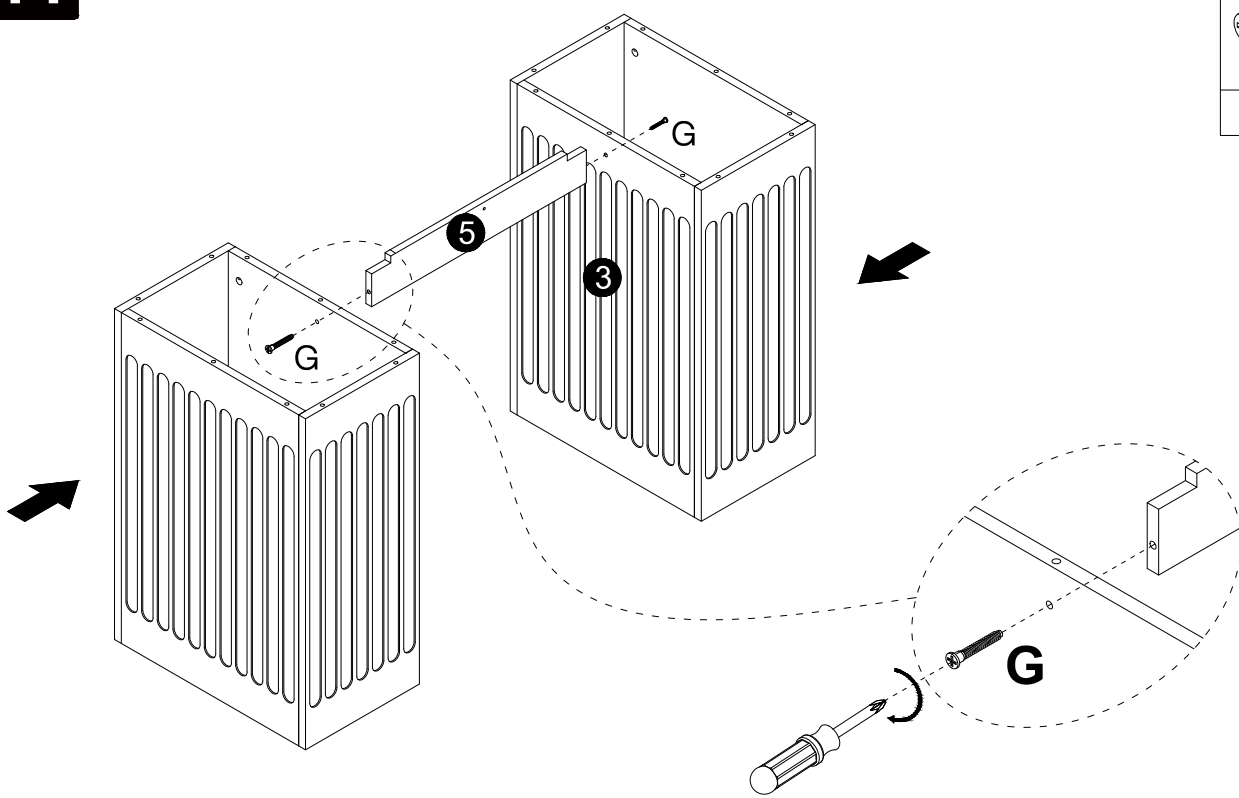
11

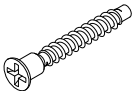

<b>G</b>

Ø7x38mm
2 pcs

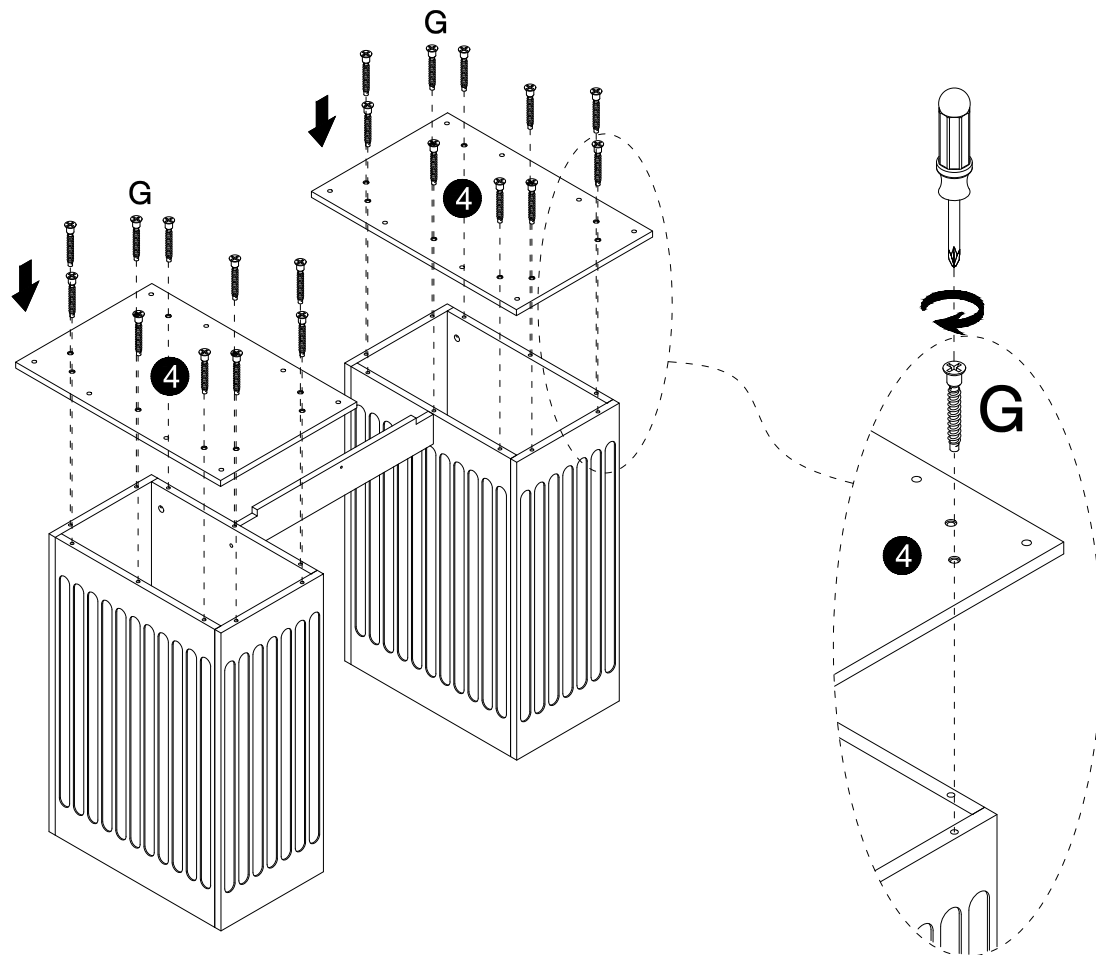
12

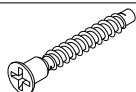

<b>G</b>

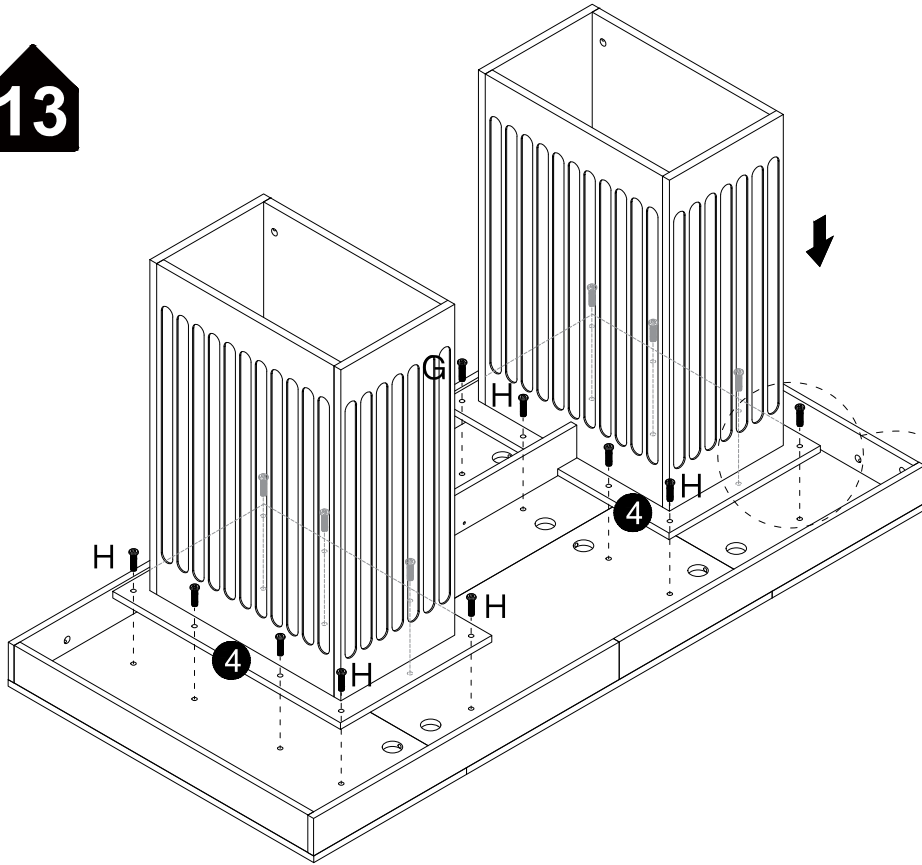
Ø7x38mm
20 pcs

13



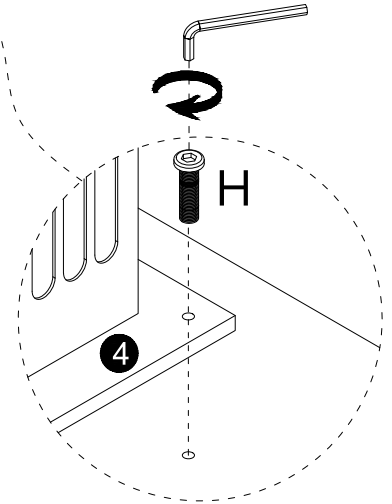

<b>H</b>

M6x25mm
16 pcs

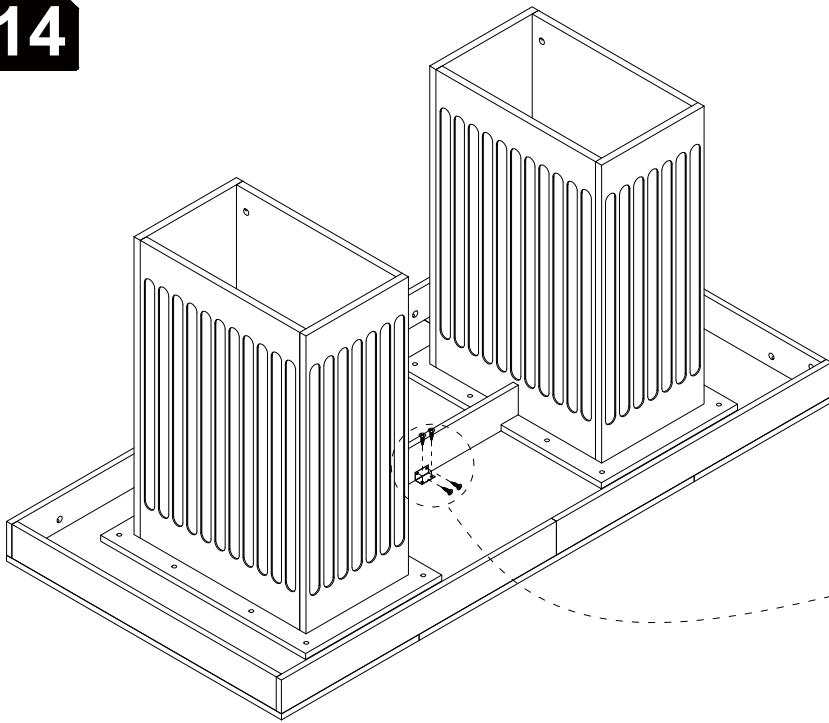

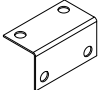
14

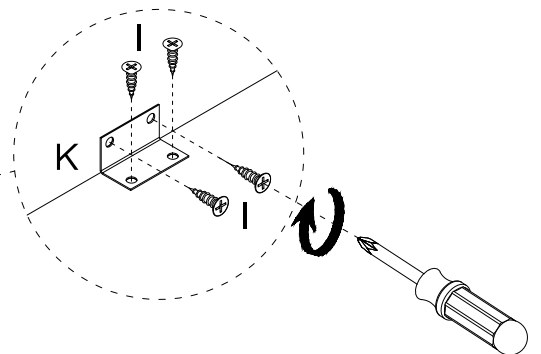

<b>K</b>	<b>I</b>
	
20x20mm	Ø3.5x14mm
1 pc	4 pcs



15

F

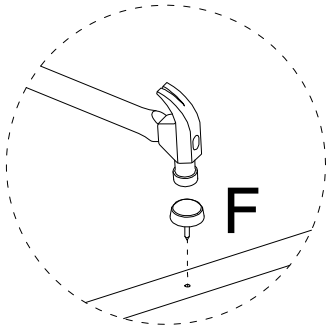
12 pcs

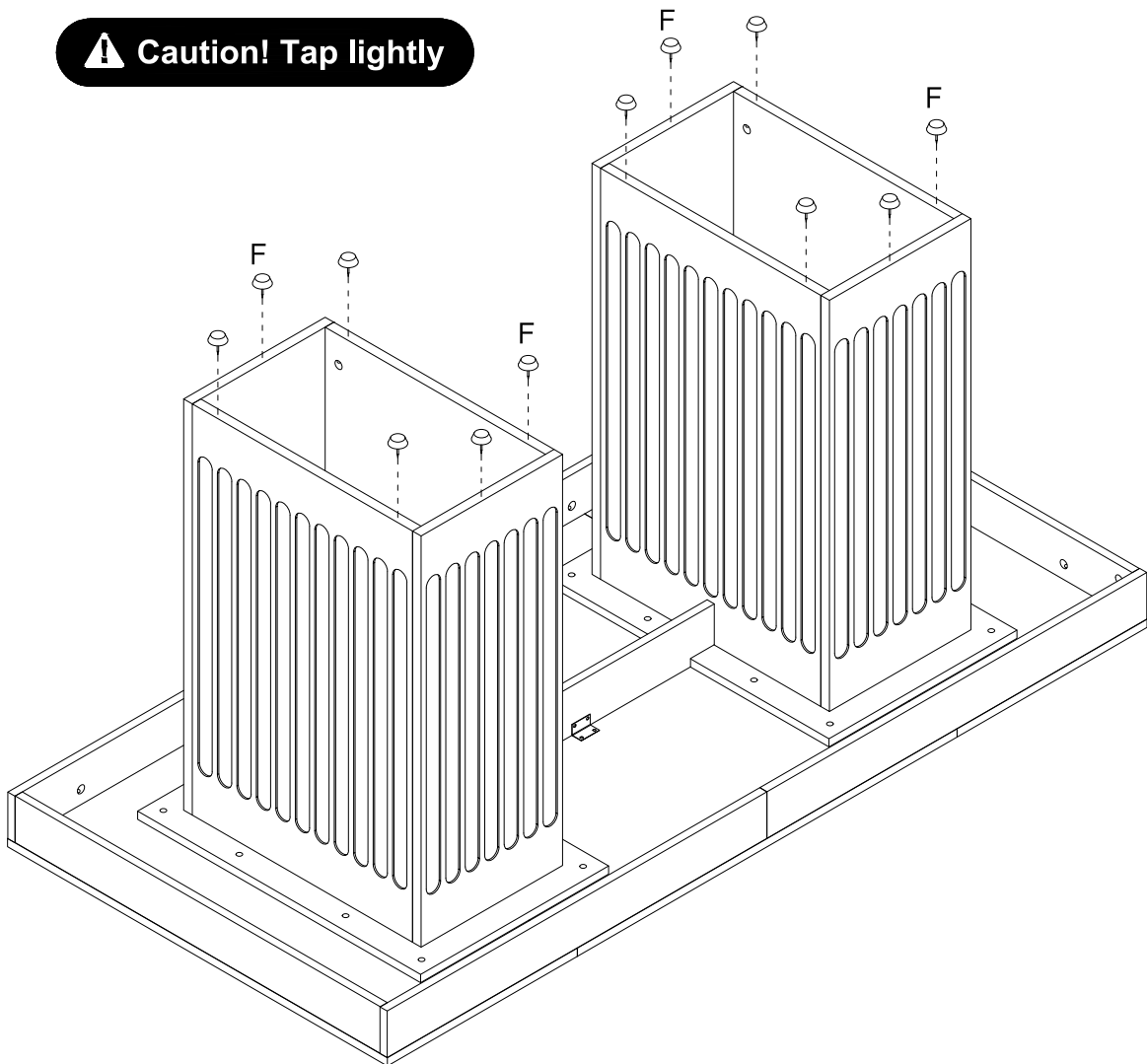

**⚠ Caution! Tap lightly**



**Thank you for your support !**

