

ASSEMBLY INSTRUCTIONS

INSTRUCTIONS DE MONTAGE

TWIN/TWIN BUNK BED WITH DESK, STAIRS

LIT SUPERPOSÉ TWIN/TWIN AVEC BUREAU, ESCALIER

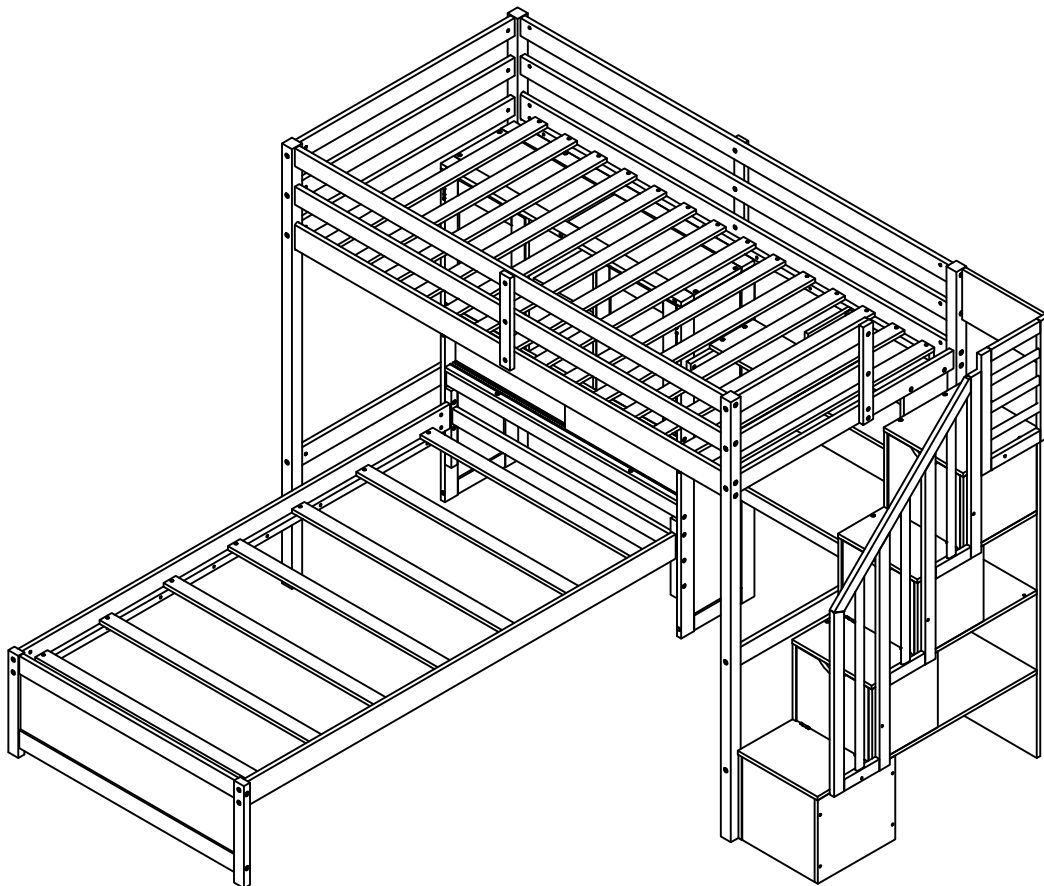

SAFETY WARNINGS AND GENERAL NOTES:

Follow the information on the warnings on the bunk bed end structure and on the carton. Do not remove the warning label from the bed. Always use the recommended size mattress on mattress support, or both, to help prevent the likelihood of entrapment or falls.

The top surface of the mattress must be at least 5*inch (127mm) below the upper edge of the guardrail.

Do not allow children under 6 years of age to use the upper bunk.

Periodically check and ensure the guardrail, ladder and other components are in their proper position, free from damage, and all connectors are tight.

Do not allow horseplay on or under beds.

Always prohibit jumping on the bed.

Prohibit more than one person on upper bunk.

Always use the ladder for entering and leaving the upper bunk.

Do not use substitute parts. Contact the manufacturer or dealer for replacement parts.

Use of a night-light may provide added safety precaution for a child using the upper bunk.

Always use guardrails on both long sides of the upper bunk.

If the bunk bed will be placed next to a wall, the guardrail that runs the full length of the bed should be placed against the wall to prevent entrapment between the bed and the wall.

The use of water or sleep flotation mattresses is prohibited.

STRANGULATION HAZARD-Never attach or hang items to any part of the bunk bed that are not designed for use with the bed.

Keep these instructions for future reference.

We recommend assembling your bunk bed on the shipping carton to protect your floor or carpet.

Be certain all staples are out of the box before beginning assembly on the shipping carton.

THIS BED IS DESIGNED TO USE A TWIN MATTRESSES 38 1/2" WIDE X 74"-75" LONG WITH THE TOTAL THICKNESS NOT EXCEEDING 6" FOR UPPER BUNK, FOR THE LOWER TWINL-SIZE SHOULD BE 38 1/2" WIDE X 74"-75" LONG, WIDE WITH 6" THICKNESS.

SURFACE OF MATTRESS MUST BE AT LEAST 5" (127MM) BELOW THE UPPER EDGE OF GUARDRAILS.

Replacement Parts:

Replacement Parts, including additional guardrails, may be obtained from any of our dealers.

AVERTISSEMENTS DE SÉCURITÉ ET REMARQUES GÉNÉRALES :

Suivez les informations sur les avertissements figurant sur la structure d'extrémité du lit superposé et sur le carton. Ne retirez pas l'étiquette d'avertissement du lit. Utilisez toujours le matelas de taille recommandée sur le support de matelas, ou les deux, pour éviter tout risque de coincement ou de chute.

La surface supérieure du matelas doit être à au moins 5*poûces (127 mm) sous le bord supérieur du garde-corps.

Ne laissez pas les enfants de moins de 6 ans utiliser le lit supérieur.

Vérifiez périodiquement et assurez-vous que le garde-corps, l'échelle et les autres composants sont dans leur bonne position, exempts de dommages et que tous les connecteurs sont bien serrés.

Ne permettez pas les chahuts sur ou sous les lits.

Interdisez toujours de sauter sur le lit.

Interdire plus d'une personne sur la couchette supérieure.

Utilisez toujours l'échelle pour entrer et sortir du lit supérieur.

N'utilisez pas de pièces de rechange. Contactez le fabricant ou le revendeur pour obtenir des pièces de rechange.

L'utilisation d'une veilleuse peut fournir une précaution supplémentaire en matière de sécurité pour un enfant utilisant le lit supérieur.

Utilisez toujours des garde-corps sur les deux côtés longs du lit supérieur.

Si le lit superposé doit être placé à côté d'un mur, le garde-corps qui s'étend sur toute la longueur du lit doit être placé contre le mur pour éviter tout coincement entre le lit et le mur.

L'utilisation de matelas flottants à eau ou de sommeil est interdite.

RISQUE D'ÉTRANGULATION - N'attachez ou ne suspendez jamais d'objets à une partie du lit superposé qui ne sont pas conçus pour être utilisés avec le lit.

Conservez ces instructions pour référence future.

Nous vous recommandons d'assembler votre lit superposé sur le carton d'expédition pour protéger votre sol ou votre tapis.

Assurez-vous que toutes les agrafes sont sorties de la boîte avant de commencer l'assemblage sur le carton d'expédition.

CE LIT EST CONÇU POUR UTILISER UN MATELAS JUMEAUX DE 38 1/2" DE LARGE X 74" - 75" DE LONG AVEC L'ÉPAISSEUR TOTALE NE DÉPASSANT PAS 6" POUR LE COUCHE SUPÉRIEUR, POUR LE JUMEL INFÉRIEUR, LA TAILLE DOIT ÊTRE DE 38 1/2" DE LARGE X 74 "-75" DE LONG, LARGE AVEC 6" D'ÉPAISSEUR.

LA SURFACE DU MATELAS DOIT ÊTRE AU MOINS 5" (127 MM) EN DESSOUS DU BORD SUPÉRIEUR DES GARDE-CORPS.

Pièces de rechange :

Les pièces de rechange, y compris les garde-corps supplémentaires, peuvent être obtenues auprès de l'un de nos revendeurs





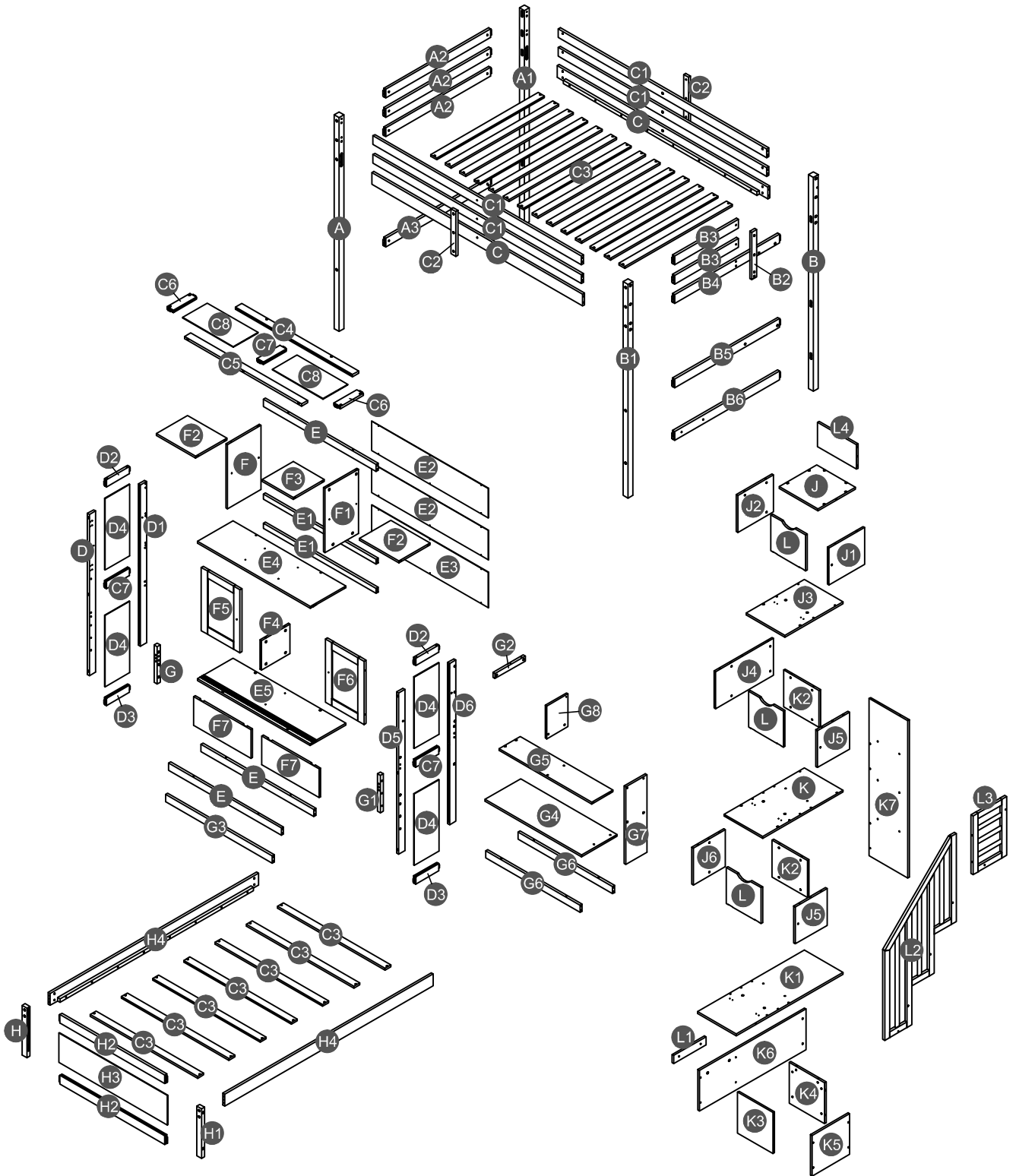





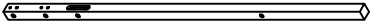
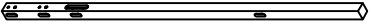
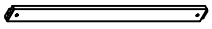

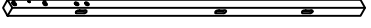
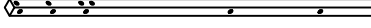
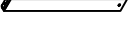
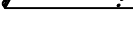
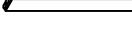
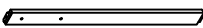
Detail View

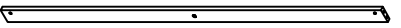
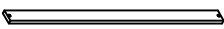
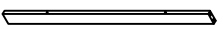
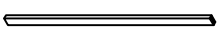
Vue Détaillée



Part List











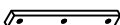
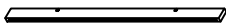





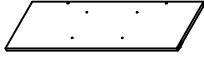

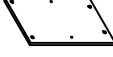
Liste des Pièces

<p>A</p>  <p>Leg (Left Front) - 1pc Pied (Avant gauche)</p>	<p>A1</p>  <p>Leg (Left Back) - 1pc Pied (Arrière gauche)</p>	<p>A2</p>  <p>Upper horizontal bar HB - 3pcs Barre horizontale supérieure HB</p>
<p>A3</p>  <p>Lower horizontal bar HB - 1pc Barre horizontale inférieure HB</p>	<p>B</p>  <p>Leg (Right Back) - 1pc Pied (arrière droit)</p>	<p>B1</p>  <p>Leg (Right Front) - 1pc Pied (Avant droit)</p>
<p>B3</p>  <p>Upper horizontal bar FB - 2pcs Barre horizontale supérieure FB</p>	<p>B4</p>  <p>Divider horizontal bar FB - 1pc Barre de séparation horizontale FB</p>	<p>B5</p>  <p>Lower horizontal bar FB - 1pc Barre horizontale inférieure FB</p>
<p>B6</p>  <p>Lower horizontal bar FB - 1pc Barre horizontale inférieure FB</p>	<p>C</p>  <p>Upper side rail - 2pcs Rail latéral supérieur</p>	<p>C1</p>  <p>Long guard rail - 4pcs Garde-corps long</p>
<p>C3</p>  <p>Slats - 10pcs Latte</p>	<p>E</p>  <p>Horizontal bar - 3pcs Barre horizontale</p>	<p>E1</p>  <p>Horizontal bar - 2pcs Barre horizontale</p>
<p>G</p>  <p>Support (left) - 1pc Support (gauche)</p>	<p>G1</p>  <p>Support (right) - 1pc Support (droite)</p>	<p>G2</p>  <p>Support - 1pc Support</p>
<p>G6</p>  <p>Horizontal bar - 2pcs Barre horizontale</p>	<p>H</p>  <p>Leg FB (Left) - 1pc Pied FB (gauche)</p>	<p>H1</p>  <p>Leg FB (Right) - 1pc Pied FB (droite)</p>
<p>H2</p>  <p>Horizontal bar FB - 2pcs Barre horizontale FB</p>	<p>H4</p>  <p>Lower side rail - 2pcs Rail latéral inférieur</p>	

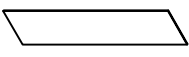
Part List



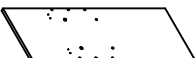
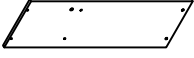
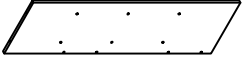













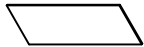
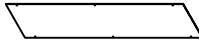
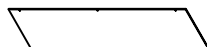
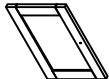
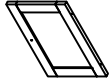



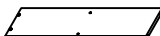





Liste des Pièces

Hardware inside / Matériel à l'intérieur

<p>B2</p>  <p>Vertical guard rail FB - 1pc Garde-corps vertical FB</p>	<p>C2</p>  <p>Vertical guard rail - 2pcs Garde-corps vertical</p>	<p>C4</p>  <p>Upper horizontal bar (Back) - 1pc Barre horizontale supérieure (Arrière)</p>
<p>C5</p>  <p>Upper horizontal bar (Front) - 1pc Barre horizontale supérieure (Avant)</p>	<p>D</p>  <p>Vertical bar (Left Front)- 1pc Barre verticale (Avant gauche)</p>	<p>D1</p>  <p>Vertical bar (Left back)- 1pc Barre verticale (Arrière gauche)</p>
<p>D5</p>  <p>Vertical bar (Right Front)- 1pc Barre verticale (Avant droit)</p>	<p>D6</p>  <p>Vertical bar (Right back)- 1pc Barre verticale (arrière droit)</p>	<p>E4</p>  <p>Upper shelf panel - 1pc Panneau d'étagère supérieur</p>
<p>E5</p>  <p>Lower shelf panel - 1pc Panneau d'étagère inférieure</p>	<p>F</p>  <p>Divider panel (left) - 1pc Panneau séparateur (gauche)</p>	<p>F1</p>  <p>Divider panel (right) - 1pc Panneau séparateur (droite)</p>
<p>F2</p>  <p>Shelf panel - 2pcs Panneau d'étagère</p>	<p>F3</p>  <p>Divider shelf panel - 1pc Panneau d'étagère séparateur</p>	<p>F4</p>  <p>Lower divider panel - 1pc Panneau de séparation inférieur</p>
<p>H3</p>  <p>Side panel FB - 1pc Panneau latéral FB</p>	<p>J</p>  <p>Upper step ladder panel -1pc Panneau d'échelle supérieur</p>	<p>J3</p>  <p>Upper center step ladder panel -1pc Panneau d'échelle central supérieur</p>
<p>K</p>  <p>Center step ladder panel -1pc Panneau d'échelle à marchepied central</p>	<p>K1</p>  <p>Lower step ladder panel -1pc Panneau d'échelle inférieure</p>	<p>K6</p>  <p>Lower left side panel - 1pc Panneau latéral inférieur gauche</p>
<p>K7</p>  <p>Back panel - 1pc Panneau arrière</p>	<p>L4</p>  <p>Upper back panel - 1pc Panneau arrière supérieur</p>	

Part List

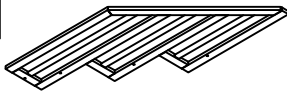



Liste des Pièces

<p>C3</p>  <p>Slats - 11pcs Latte</p>	<p>C6</p>  <p>Upper horizontal bar - 2pcs Barre horizontale supérieure</p>	<p>C7</p>  <p>Divider horizontal bar - 3pcs Barre de séparation horizontale</p>
<p>C8</p>  <p>Top panel - 2pcs Panneau du haut</p>	<p>D2</p>  <p>Upper horizontal bar - 2pcs Barre horizontale supérieure</p>	<p>D3</p>  <p>Lower horizontal bar - 2pcs Barre horizontale inférieure</p>
<p>D4</p>  <p>Side panel - 4pcs Panneau latéral</p>	<p>E2</p>  <p>Upper back panel - 2pcs Panneau arrière supérieur</p>	<p>E3</p>  <p>Lower back panel - 1pc Panneau arrière inférieure</p>
<p>F5</p>  <p>Door (left) - 1pc Porte (gauche)</p>	<p>F6</p>  <p>Door (right) - 1pc Porte (droite)</p>	<p>F7</p>  <p>Door sliding - 2pcs Porte coulissante</p>
<p>G3</p>  <p>Lower horizontal bar - 1pc Barre horizontale inférieure</p>	<p>G4</p>  <p>Top table - 1pc Table haute</p>	<p>G5</p>  <p>Shelf panel - 1pc Panneau d'étagère</p>
<p>G7</p>  <p>Side panel (right) - 1pc Panneau latéral (droite)</p>	<p>G8</p>  <p>Divider panel - 1pc Panneau séparateur</p>	<p>J1</p>  <p>Upper right side panel - 1pc Panneau latéral supérieur droit</p>
<p>J2</p>  <p>Upper left side panel - 1pc Panneau latéral supérieur gauche</p>	<p>J4</p>  <p>Upper center left side panel - 1pc Panneau latéral supérieur central gauche</p>	<p>J5</p>  <p>Center right side panel - 2pcs Panneau latéral droit central</p>
<p>J6</p>  <p>Center left side panel - 1pc Panneau latéral central gauche</p>	<p>K2</p>  <p>Center panel - 2pcs Panneau central</p>	<p>K3</p>  <p>Lower front panel - 1pc Panneau avant inférieur</p>
<p>K4</p>  <p>Lower center panel - 1pc Panneau central inférieur</p>	<p>K5</p>  <p>Lower right side panel - 1pc Panneau latéral inférieur droit</p>	<p>L</p>  <p>Upper front panel - 3pcs Panneau avant supérieur</p>
<p>L1</p>  <p>Support - 1pc Support</p>	<p>L2</p>  <p>Guard rail (Front) - 1pc Garde-corps (Avant)</p>	<p>L3</p>  <p>Guard rail (Back) - 1pc Garde-corps (arrière)</p>

Hardware List

Liste des Accessoires

1	 Ø10*40mm	2	 Ø8*30mm	3	 (Ø15)1/4"*100mm
Wood dowel (8pcs) Cheville en bois		Wood dowel (46pcs) Cheville en bois		Hex-Head bolts (16pcs) Boulons à tête hexagonale	
4	 (Ø15)1/4"*80mm	5	 (Ø12)1/4"*60mm	6	 (Ø12)1/4"*40mm
Hex-Head bolts (31pcs) Boulons à tête hexagonale		Hex-Head bolts (69pcs) Boulons à tête hexagonale		Hex-Head bolts (8pcs) Boulons à tête hexagonale	
7	 (Ø12)1/4"*30mm	8	 1/4"*15 (9.5mm)	9	 (Ø12)1/4"*65mm
Hex-Head bolts (17pcs) Boulons à tête hexagonale		Horizontal-Hole bolts(114pcs) Boulons à trou horizontal		Hex-Head bolts (18pcs) Boulons à tête hexagonale	
10	 (Ø12)1/4"*40mm	11	 Ø4*30mm	12	 Ø3.5*15mm
Hex-Head bolts (16pcs) Boulons à tête hexagonale		Wood screws (42pcs) Vis		Wood screws (106pcs) Vis	
13	 Ø3.5*15mm	14	 66*39*28mm (135°)	15	 42*12*1mm
Wood screws (18pcs) Vis		Metal bracket (4pcs) Support métallique		Metal magnet (5pcs) Aimant en métal	
16	 45*17*13mm	17	 Ø38*31mm	18	 3/16"*25mm
Door catch (5pcs) Loquet de porte		Pine Knob (2pcs) Poignée pin		Ph zinc(Knob) (2pcs) Boulons (Poignée)	
19	 Ø7"*35mm	20	 Ø14*9mm	21	 L58*51*12mm
Cam lock (28pcs) Serrure à came		Cam lock (28pcs) Serrure à came		Sliding wheel (4pcs) Roue coulissante	



22  L58*51*12mm Sliding wheel (4pcs) Roue coulissante	23  50*24*24*2mm Metal bracket (1pc) Support métallique	24  40*17*17*1.6mm Metal bracket (2pcs) Support métallique
25  28*28*24*2mm Metal bracket (1pc) Support métallique	26  (1/4")4.5*58mm Allen key (1pc) Clé Allen	

ASSEMBLY TOOLS REQUIRED (NOT INCLUDED)
OUTILS D'ASSEMBLAGE REQUIS (NON INCLUS)



PLEASE BE CAREFUL DO NOT DAMAGE THE HOLE POSITION WHEN YOU USE POWER TOOLS !
NE PAS UTILISEZ DES OUTILS ÉLECTRIQUES POUR ASSEMBLER CE PRODUIT !

STEP 1:
ÉTAPE

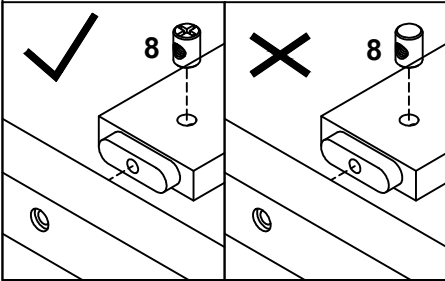
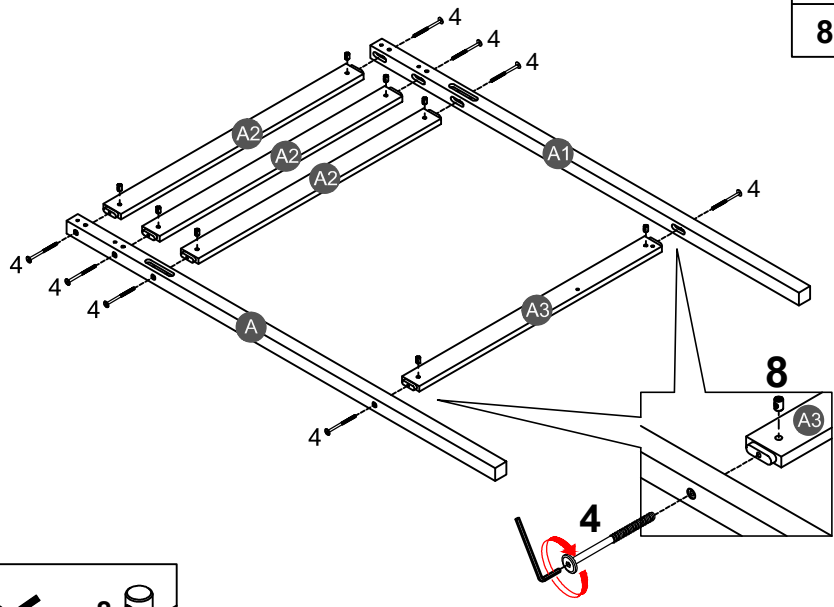

4		8	
8PCS		8PCS	



Note: Part 8 will face up with the "x" mark on it, otherwise it cannot be tightened

Remarque: La pièce 8 sera face vers le haut avec la marque "x", sinon elle ne peut pas être serrée.

STEP 2:
ÉTAPE

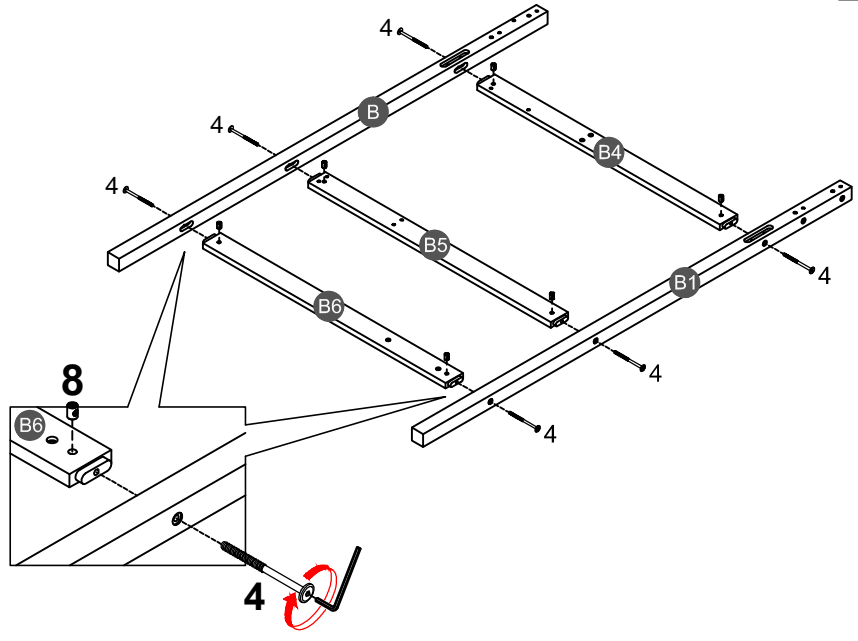

4		8	
6PCS		6PCS	

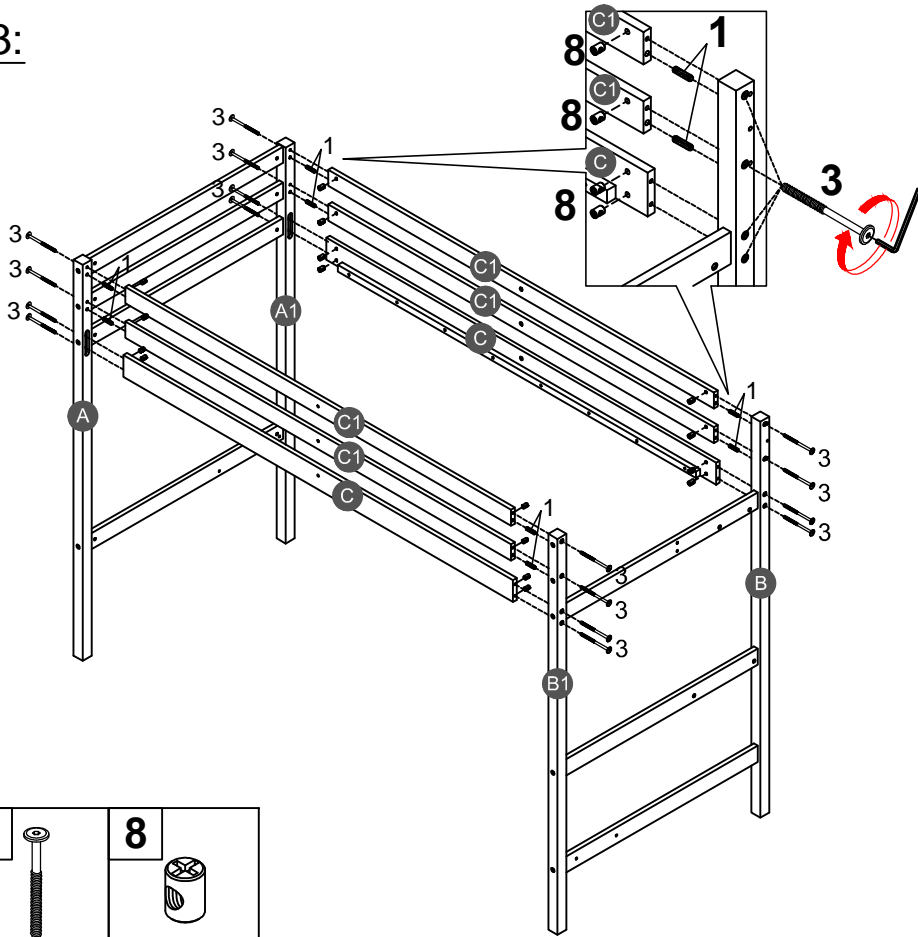

STEP 3:

ÉTAPE



1		3		8	
8PCS		16PCS		16PCS	

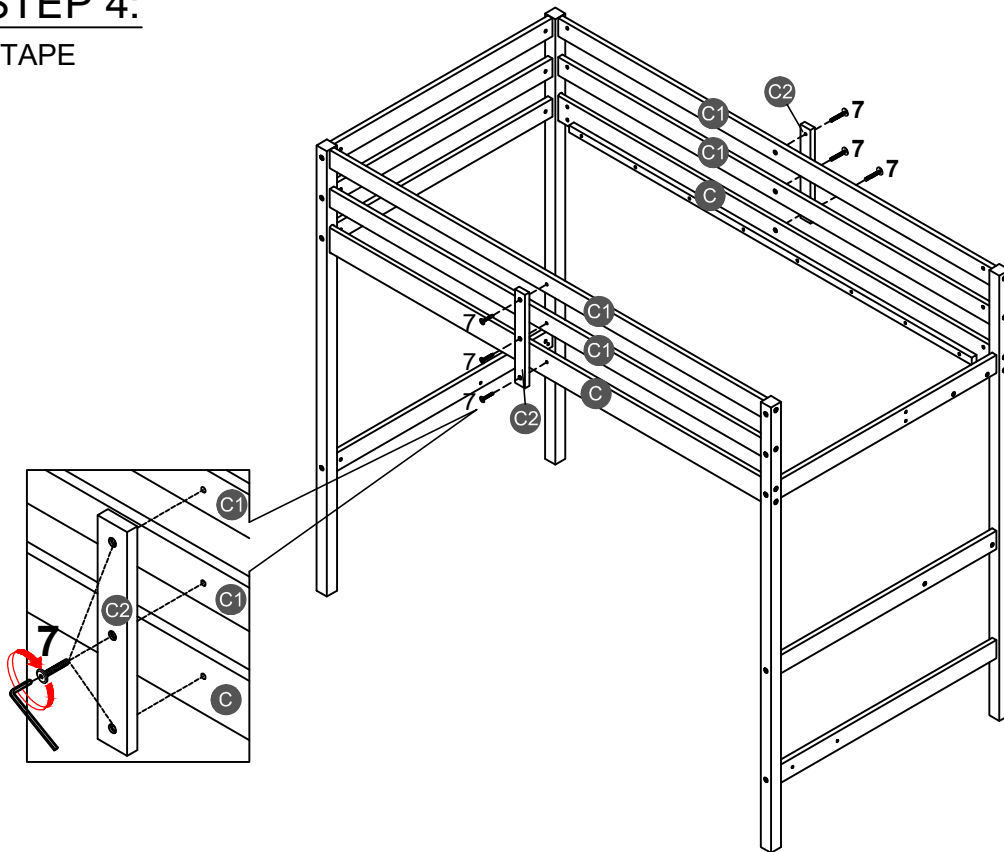

STEP 4:

ÉTAPE



7	
6PCS	

STEP 5:
ÉTAPE

4		7		8	
2PCS		4PCS		2PCS	

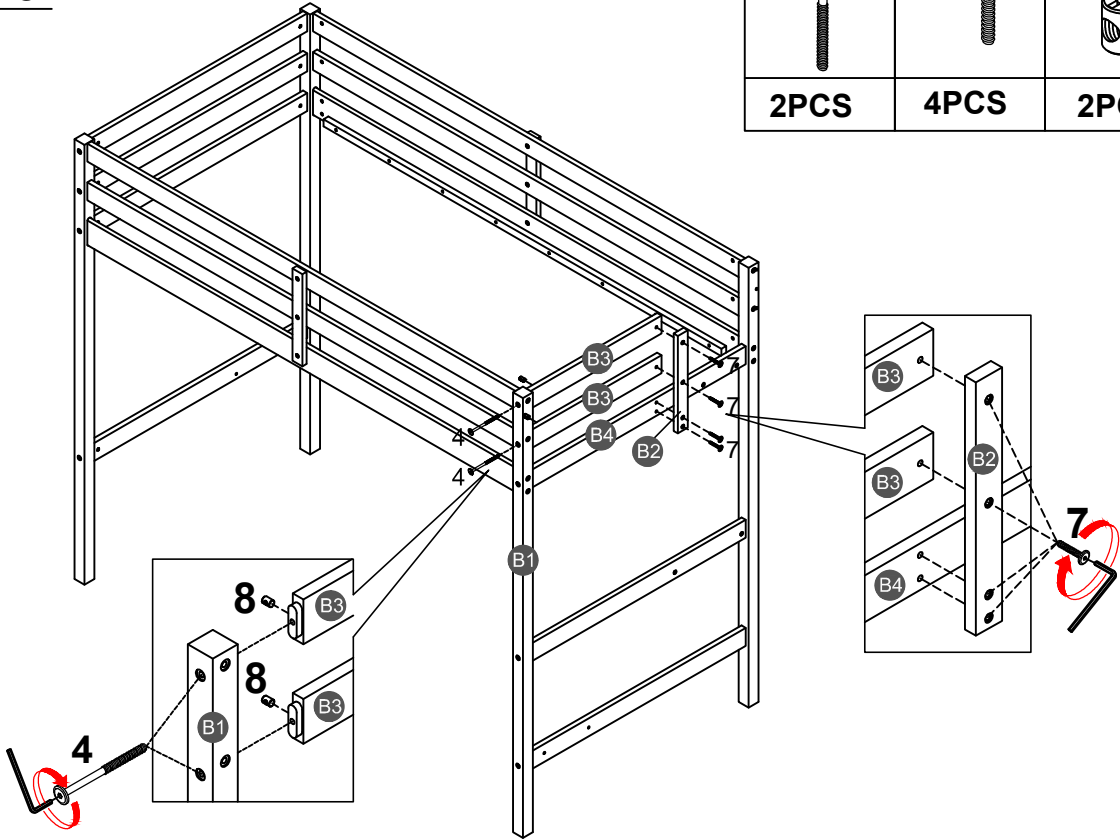

STEP 6:
ÉTAPE

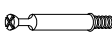
19	
8PCS	

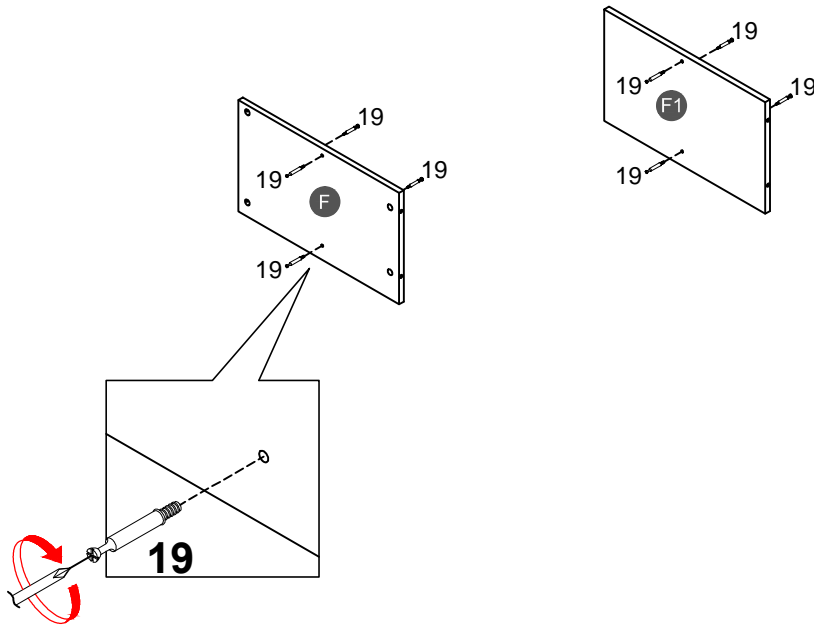

STEP 7:
ÉTAPE

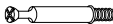
19

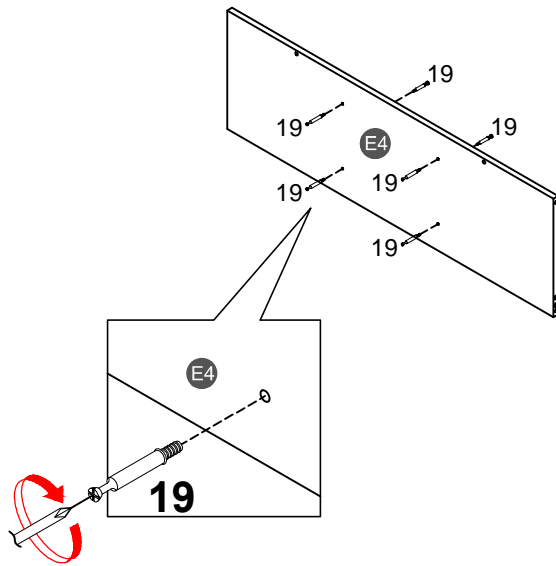
6PCS

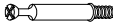

STEP 8:
ÉTAPE

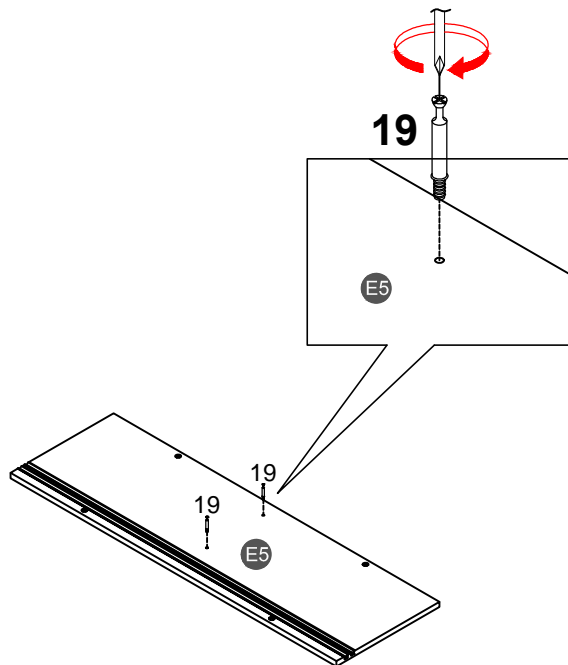
19

2PCS



STEP 9:

ÉTAPE

20



4PCS

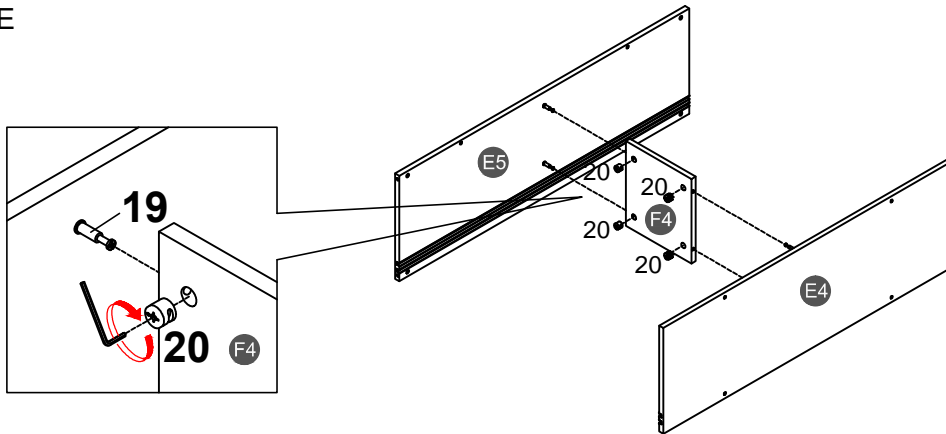

Note: Place hardware #20 with the "X" face outward, and make sure that the arrowhead is upward. Then, place hardware #20 into the hole of hardware #19 and tighten it clockwise with a hand screwdriver. (Please do NOT use an electric screwdriver.)

Remarque : placez la quincaillerie #20 avec la face « X » vers l'extérieur, et assurez-vous que la pointe de la flèche est vers le haut. Ensuite, placez le matériel #20 dans le trou de la quincaillerie #19 et serrez-le dans le sens des aiguilles d'une montre avec un tournevis à main. (Veuillez ne PAS utiliser de tournevis électrique.)

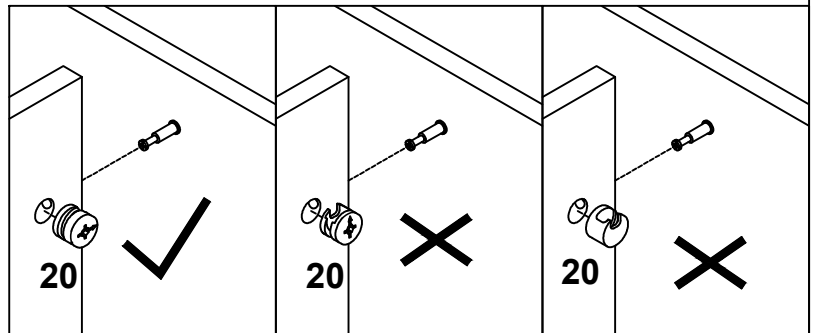

STEP 10:

ÉTAPE

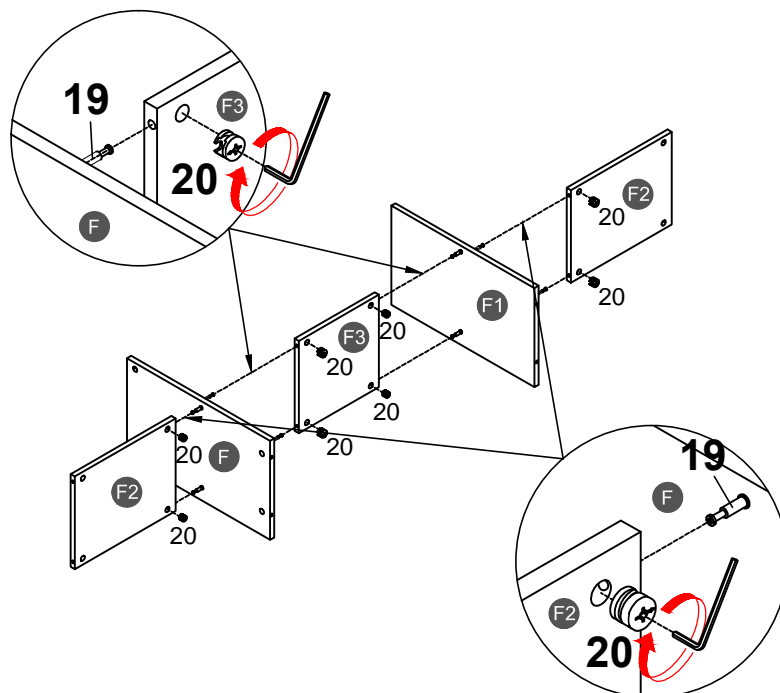

20



8PCS

STEP 11:
ÉTAPE

20



4PCS

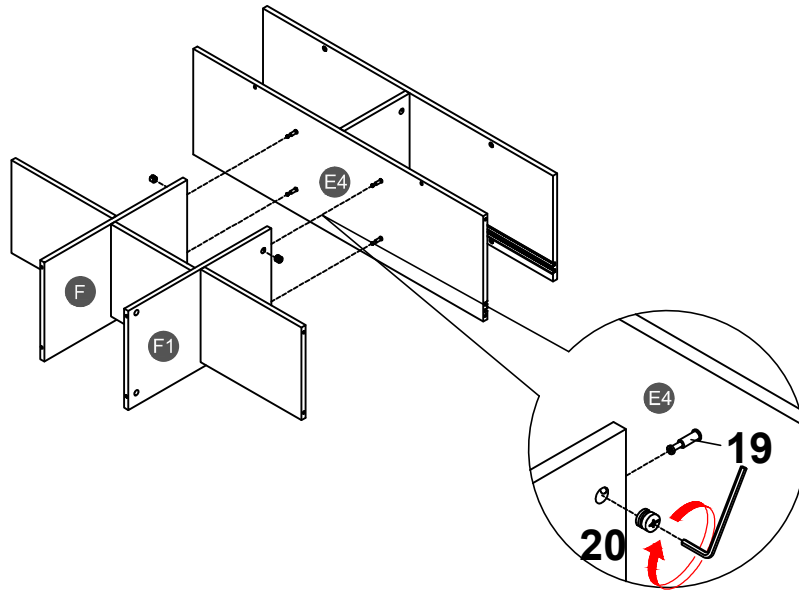

STEP 12:
ÉTAPE

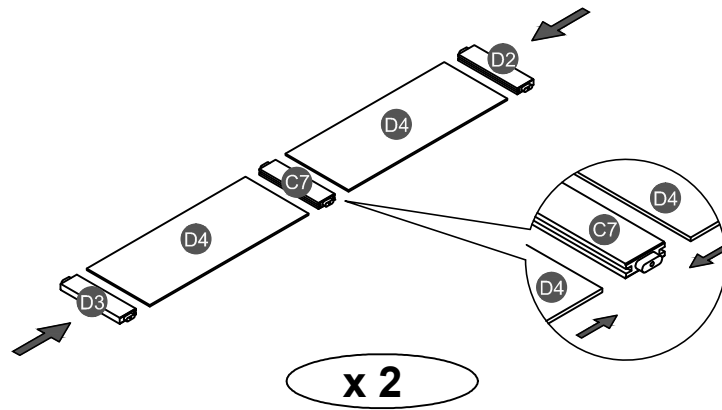

STEP 13:
ÉTAPE

9



12PCS

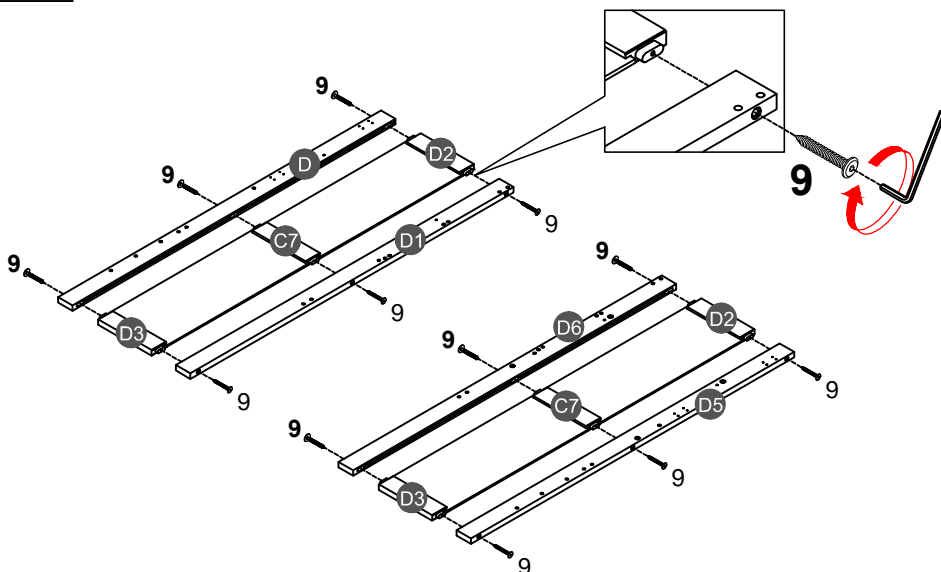

STEP 14:

ÉTAPE

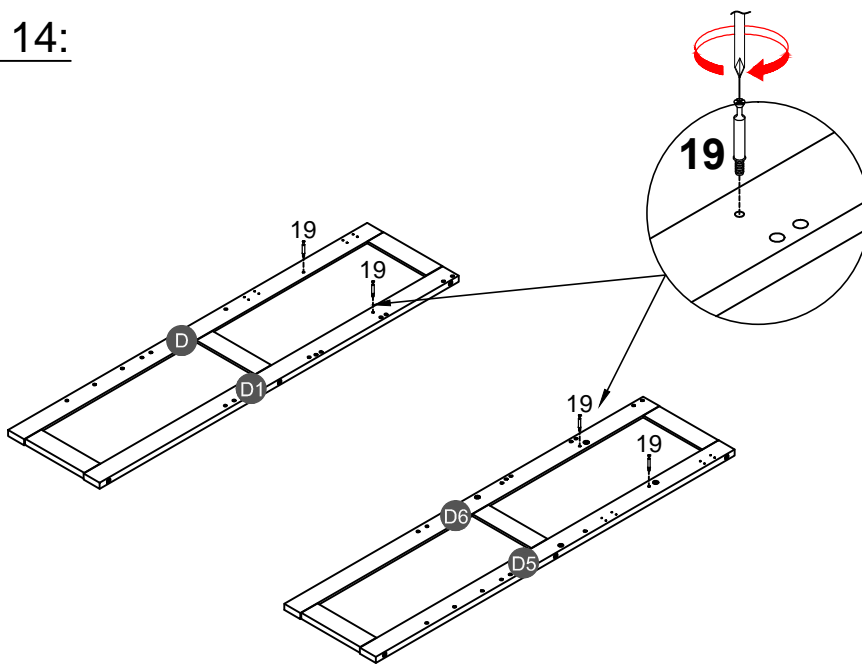

19

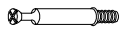

4PCS

STEP 15:

ÉTAPE

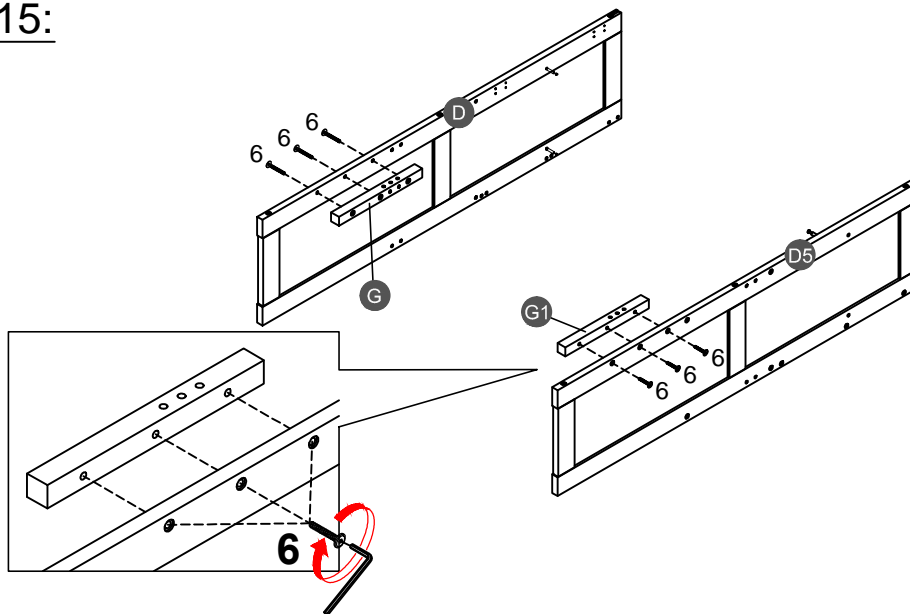

6



6PCS

STEP 16:

ÉTAPE

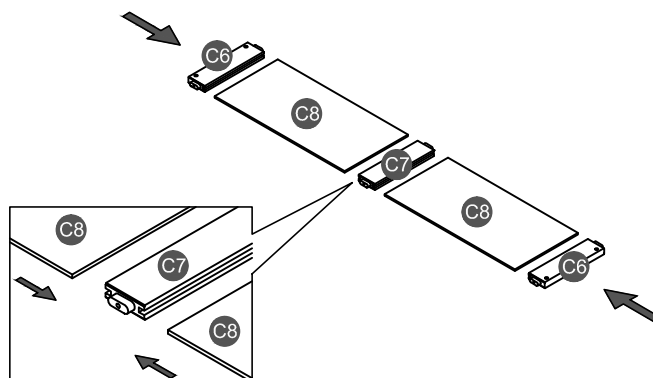

STEP 17:

ÉTAPE

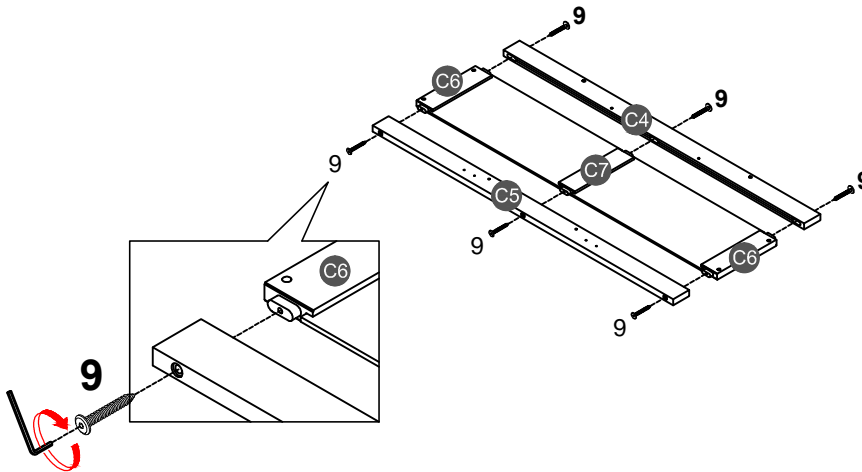

9



6PCS

STEP 18:

ÉTAPE

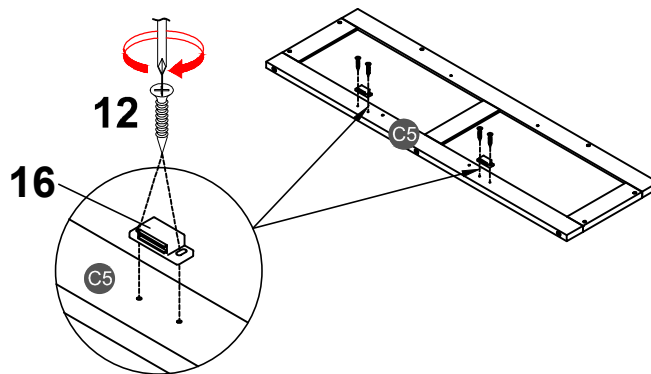

12



4PCS

16

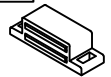

2PCS

STEP 19:

ÉTAPE

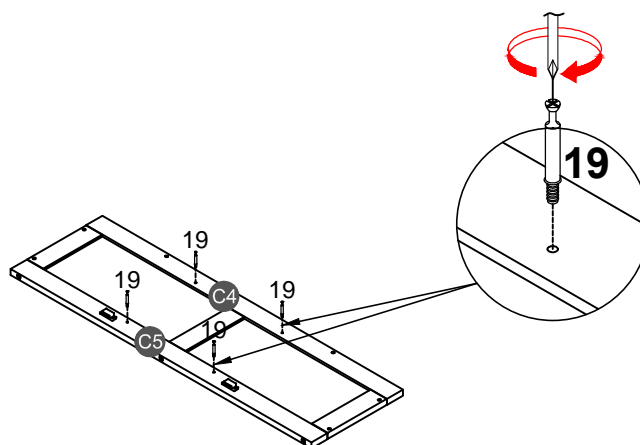

19

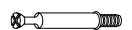

4PCS

STEP 20:

ÉTAPE

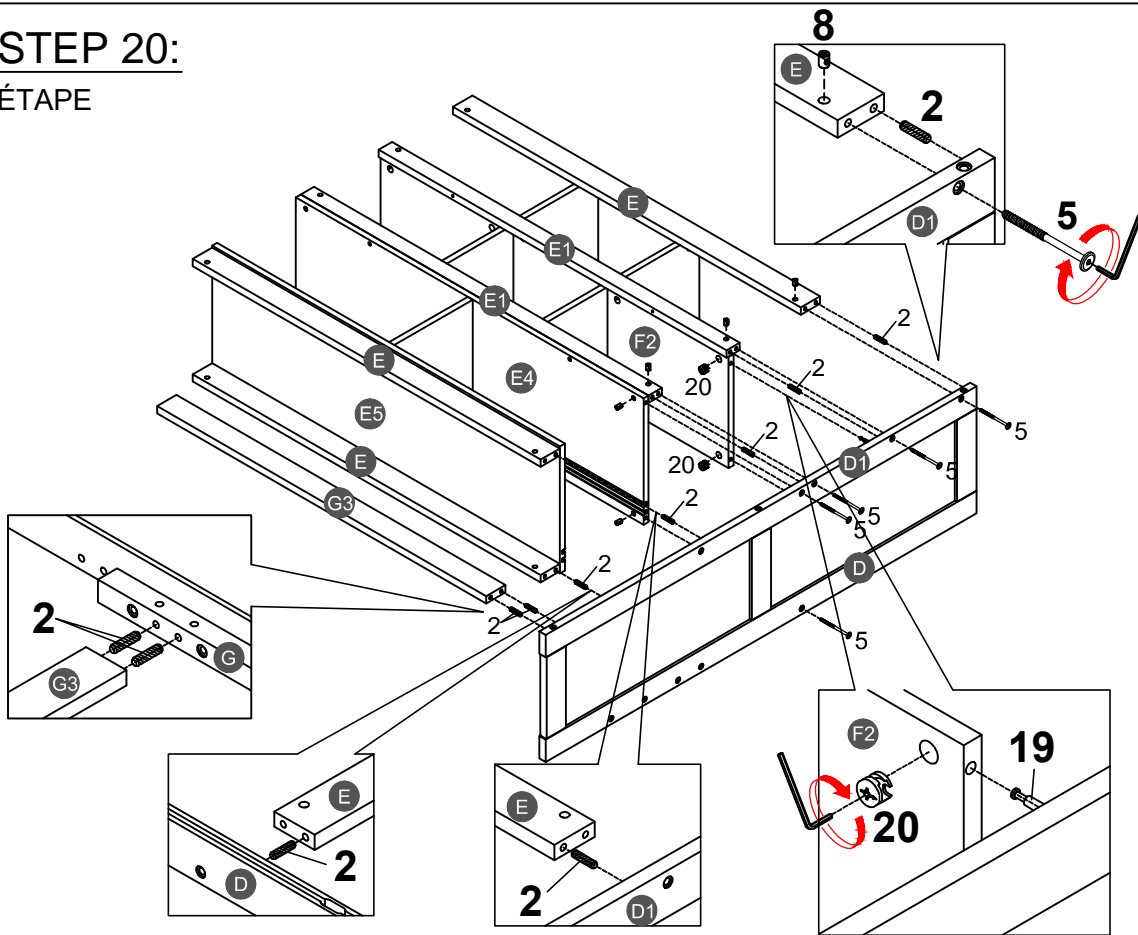

2		7PCS
5		5PCS
8		5PCS
20		2PCS

STEP 21:

ÉTAPE

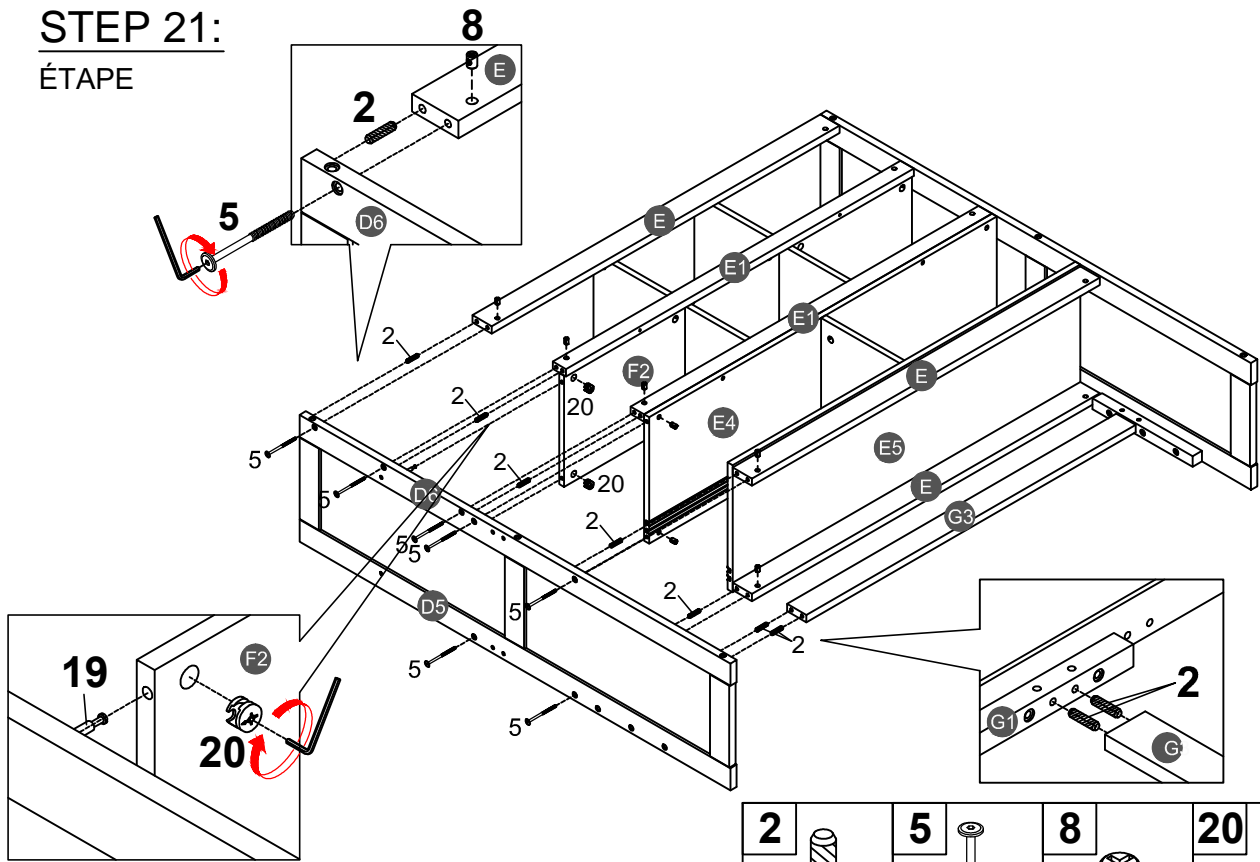



2		5		8		20	
7PCS		7PCS		7PCS		2PCS	

STEP 22:

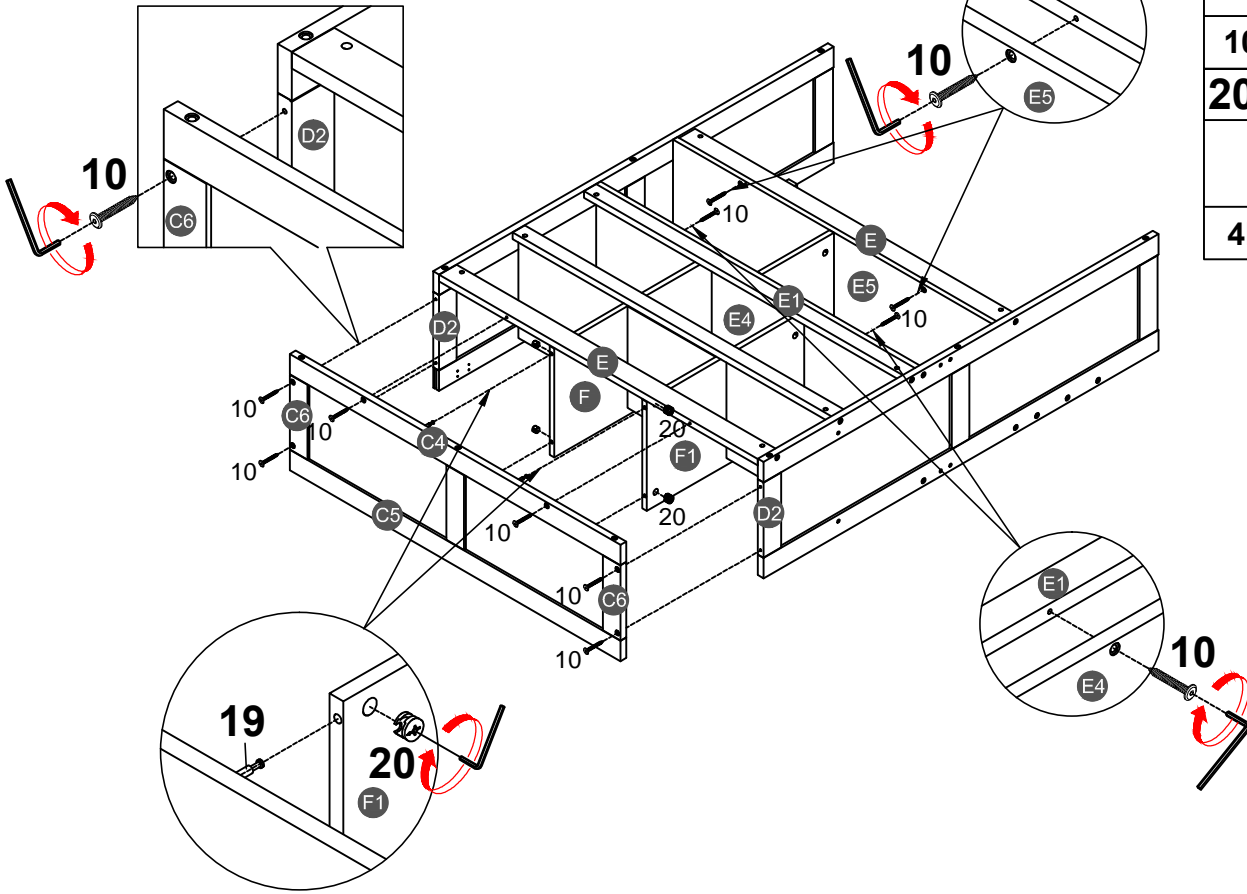
ÉTAPE



- 10 
- 10PCS
- 20 
- 4PCS

STEP 23:

ÉTAPE

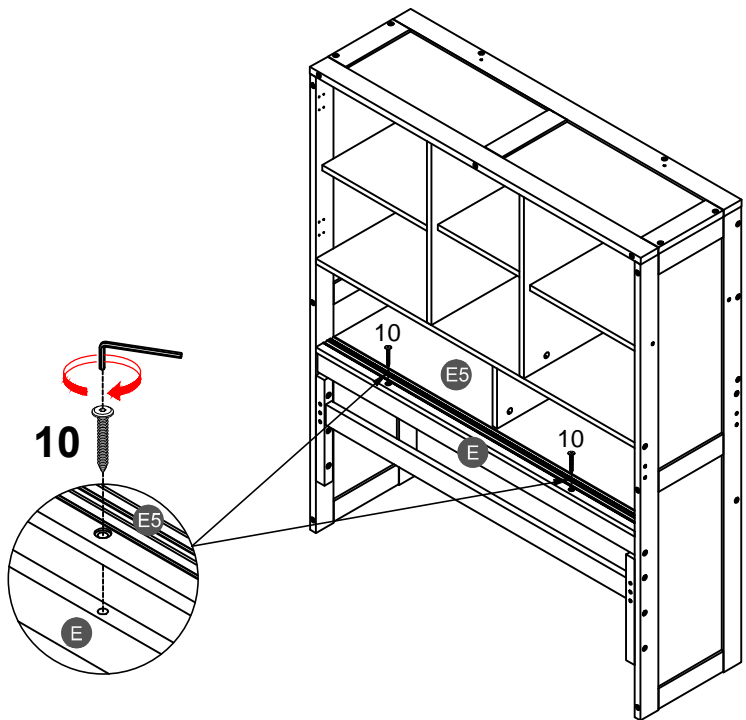

- 10 
- 2PCS

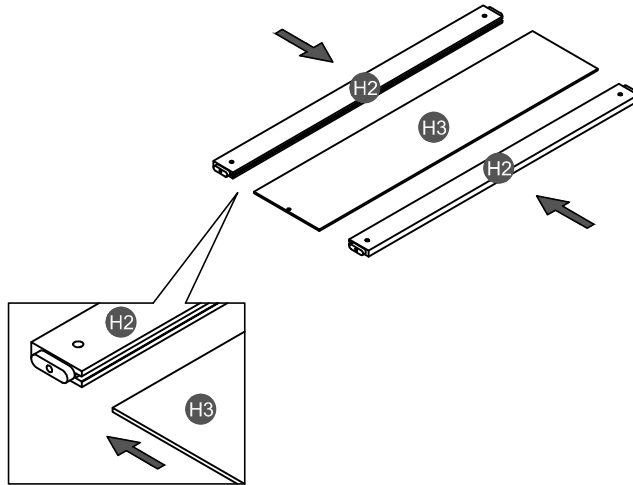

STEP 24:

ÉTAPE



STEP 25:

ÉTAPE

4	8
	
4PCS	4PCS

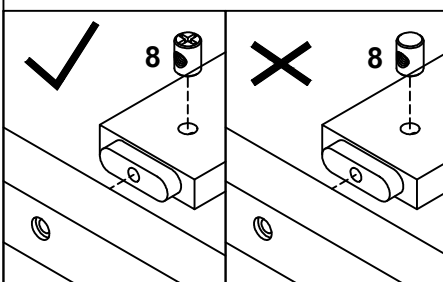
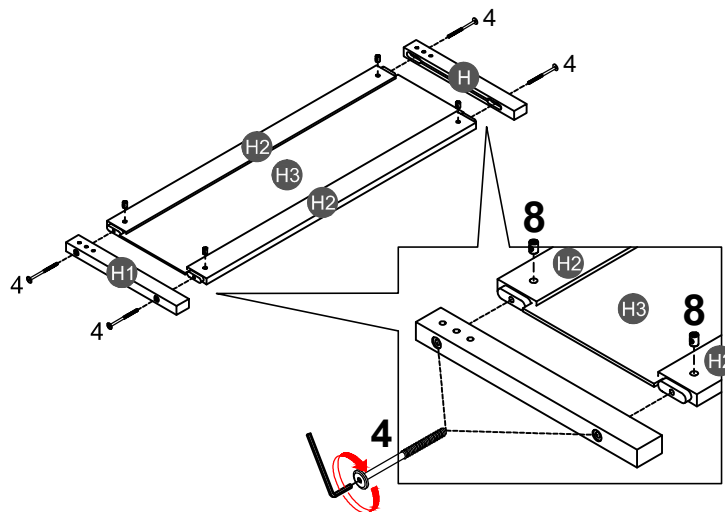

Note: Part 8 will face up with the "x" mark on it, otherwise it cannot be tightened

Remarque: La pièce 8 sera face vers le haut avec la marque "x", sinon elle ne peut pas être serrée.

STEP 26:

ÉTAPE

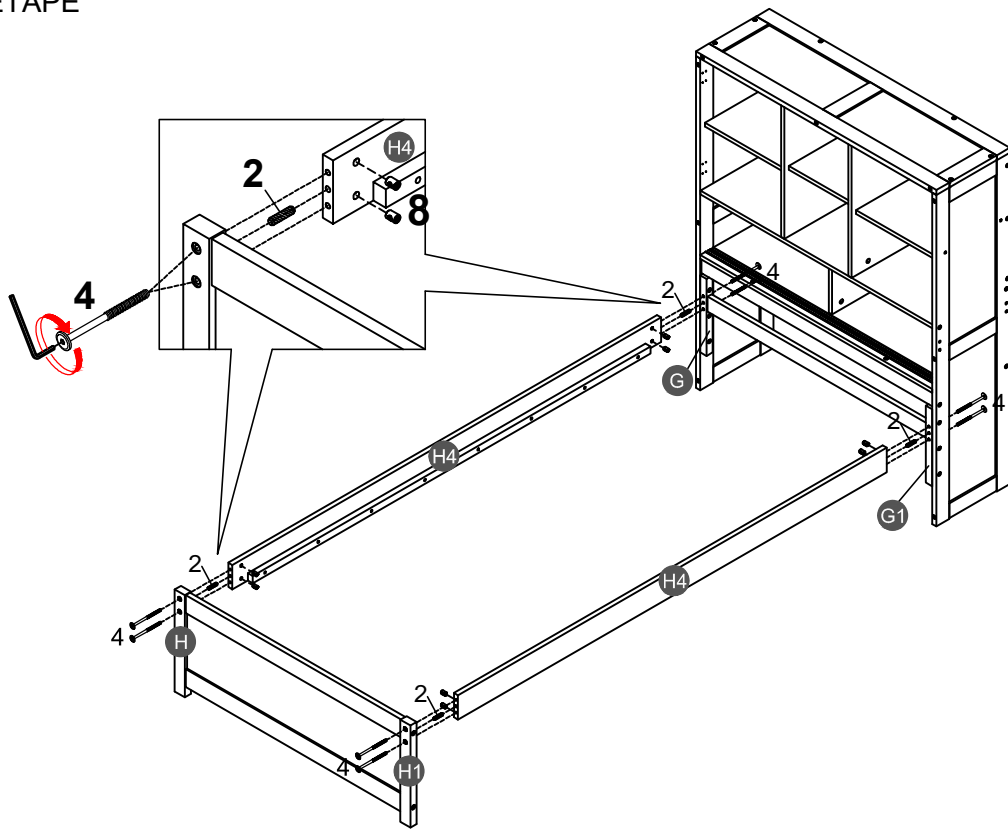

2



4PCS

4



8PCS

8



8PCS

STEP 27:

ÉTAPE

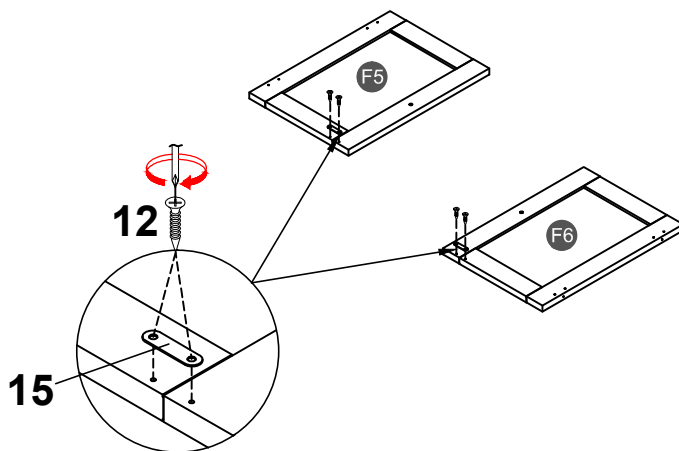

12



4PCS



15



2PCS

STEP 28:

ÉTAPE

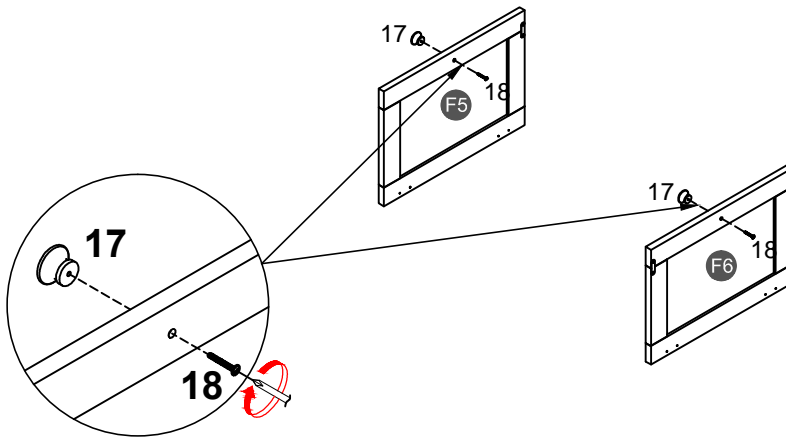

17		18	
2PCS		2PCS	

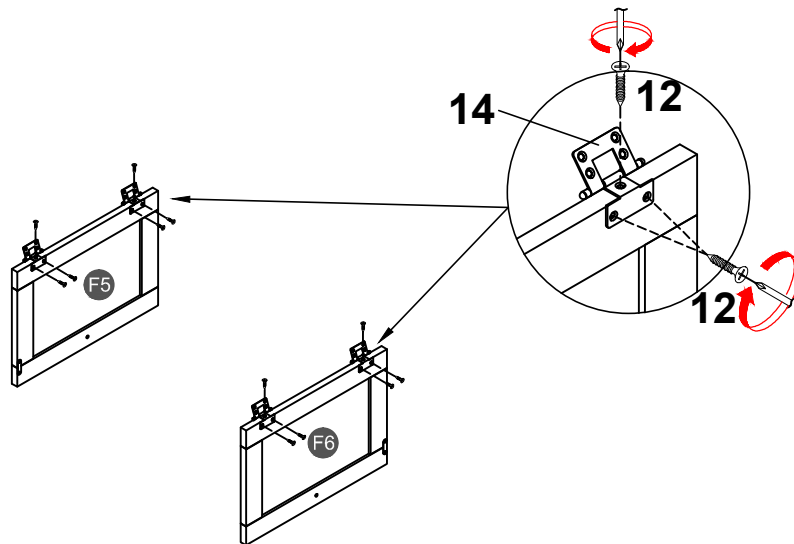

STEP 29:

ÉTAPE





12		14	
12PCS		4PCS	

STEP 30:

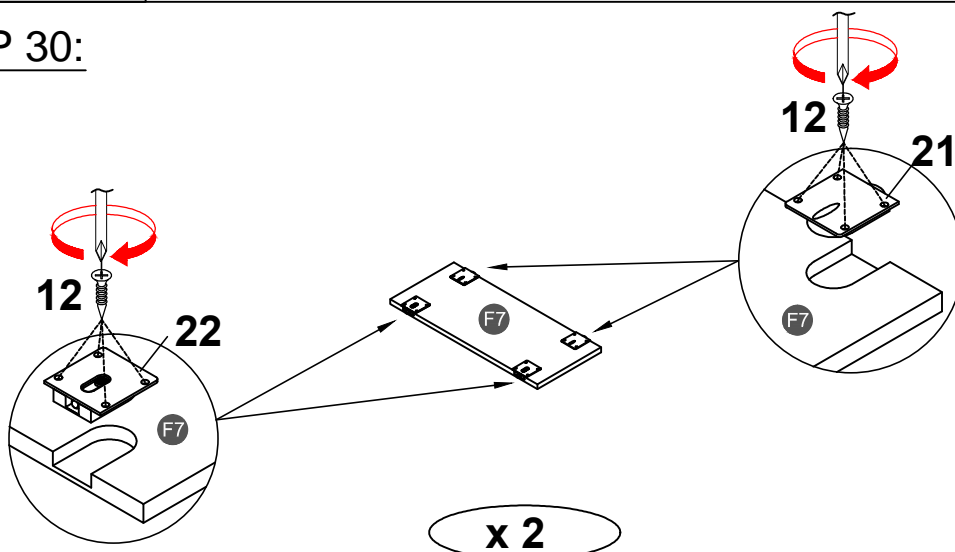
ÉTAPE



12		32PCS
21		4PCS
22		4PCS

STEP 31:

ÉTAPE

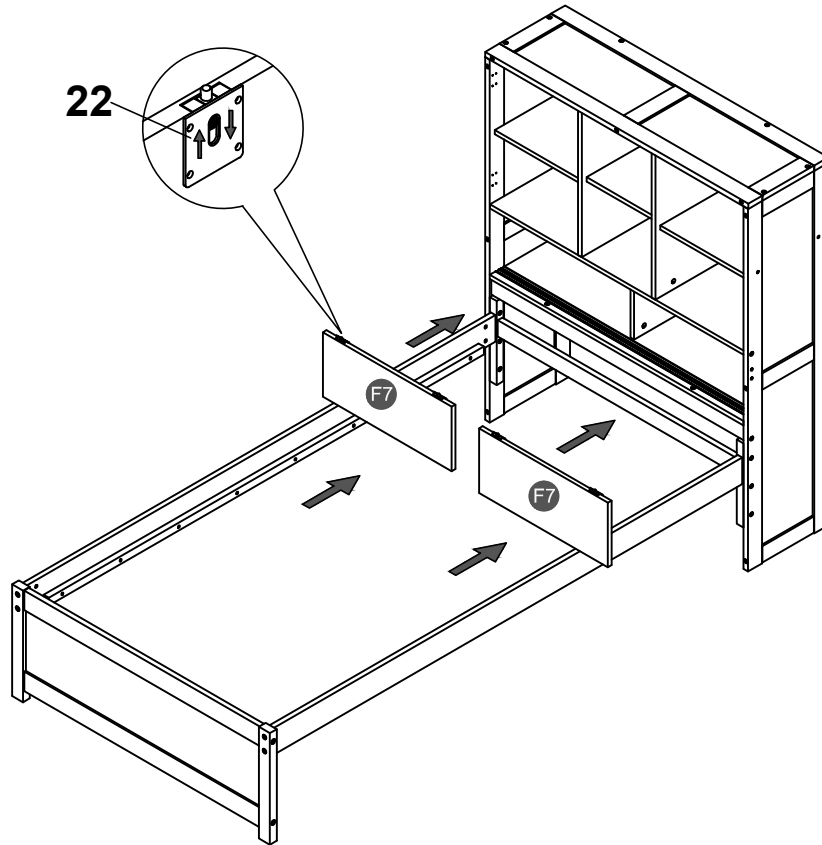

STEP 32:

ÉTAPE

12 
16PCS

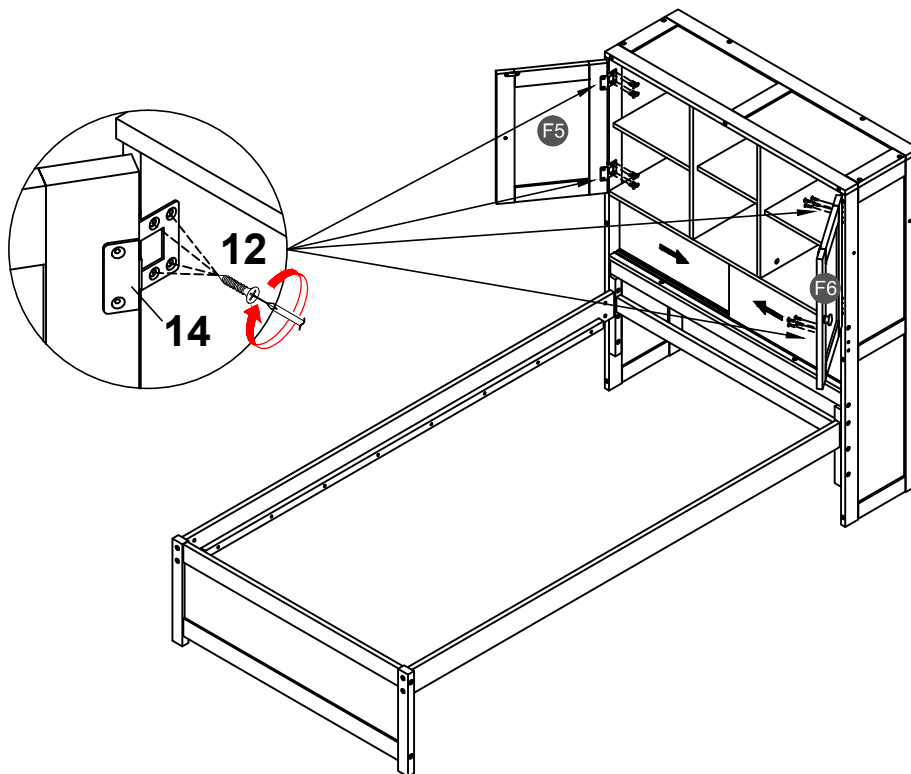

STEP 33:

ÉTAPE

7



2PCS

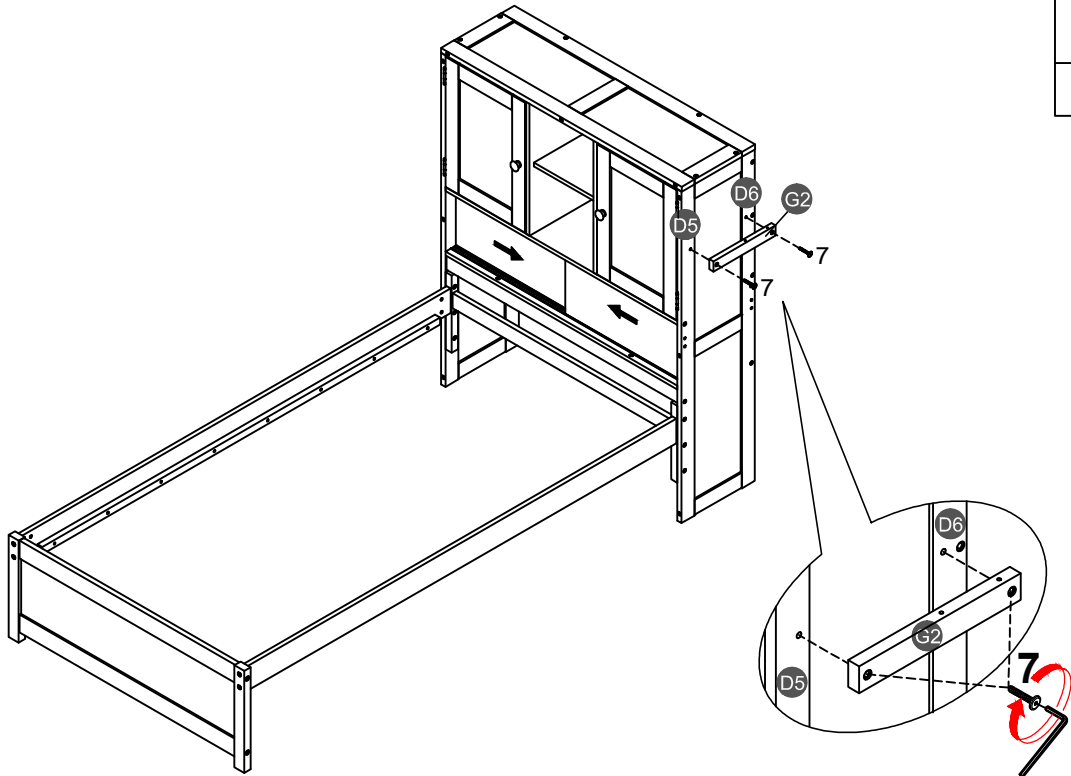

STEP 34:

ÉTAPE

4



2PCS

8



2PCS

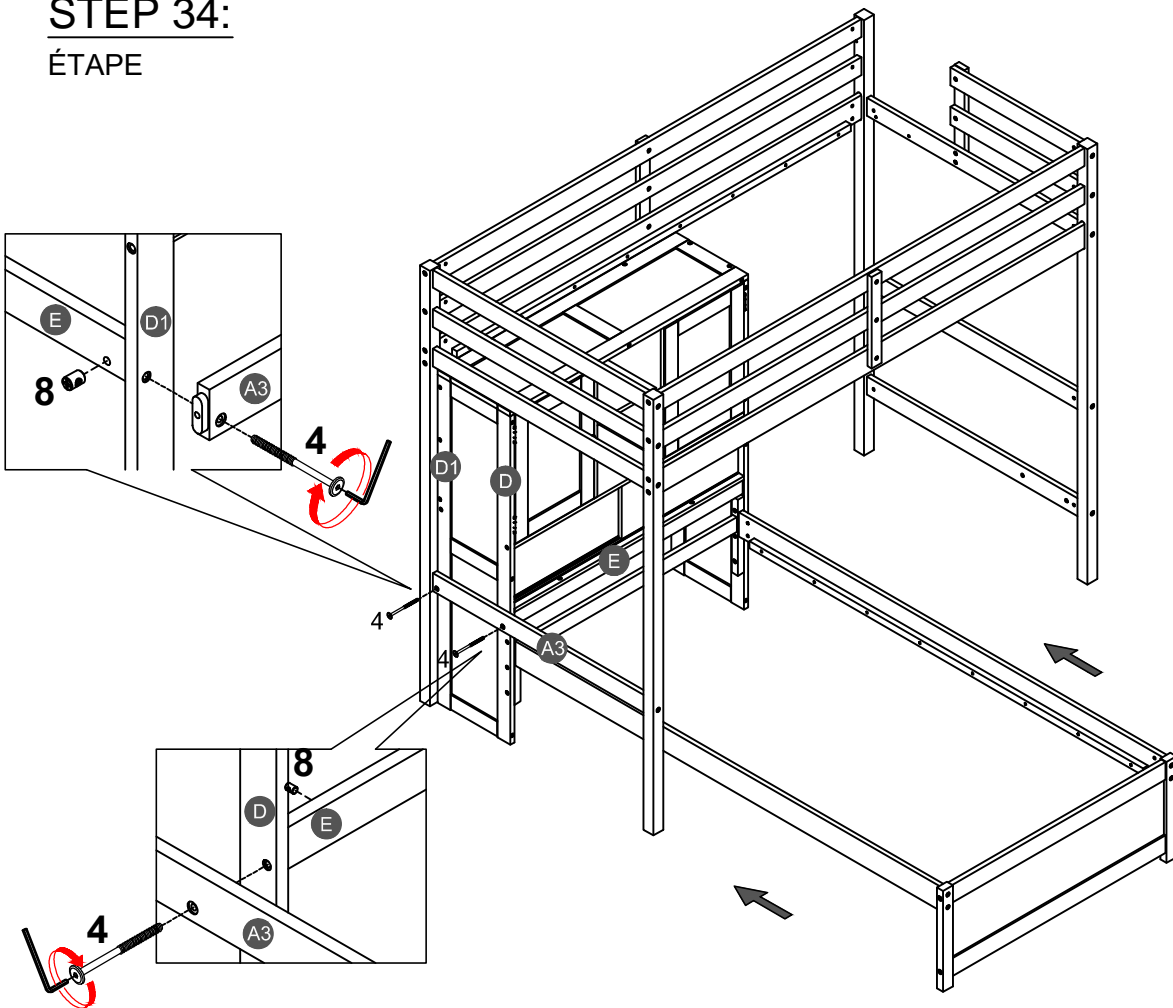

STEP 35:

ÉTAPE

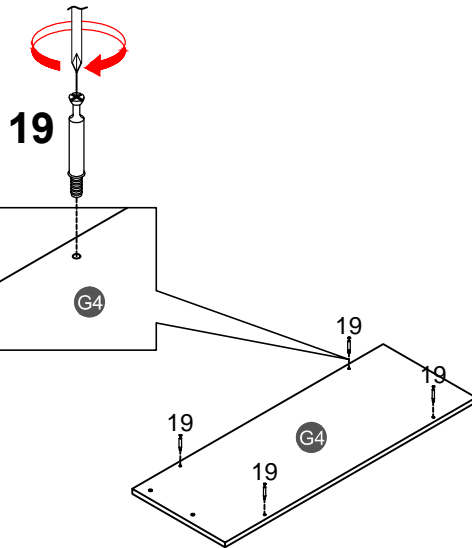

19

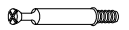

4PCS

STEP 36:

ÉTAPE

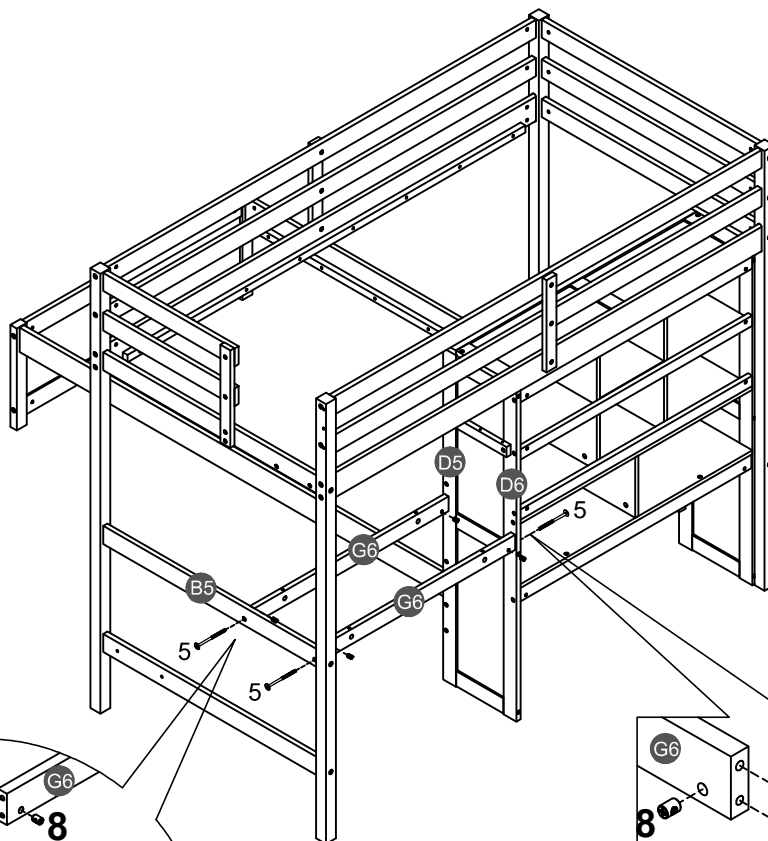

2



4PCS

5



4PCS

8



4PCS

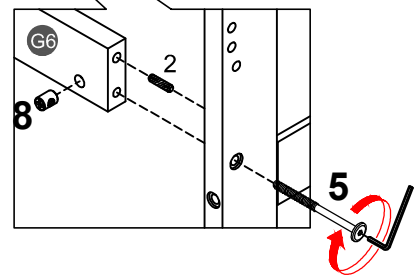
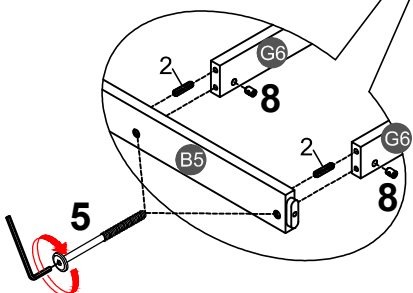

STEP 37:

ÉTAPE

20



4PCS

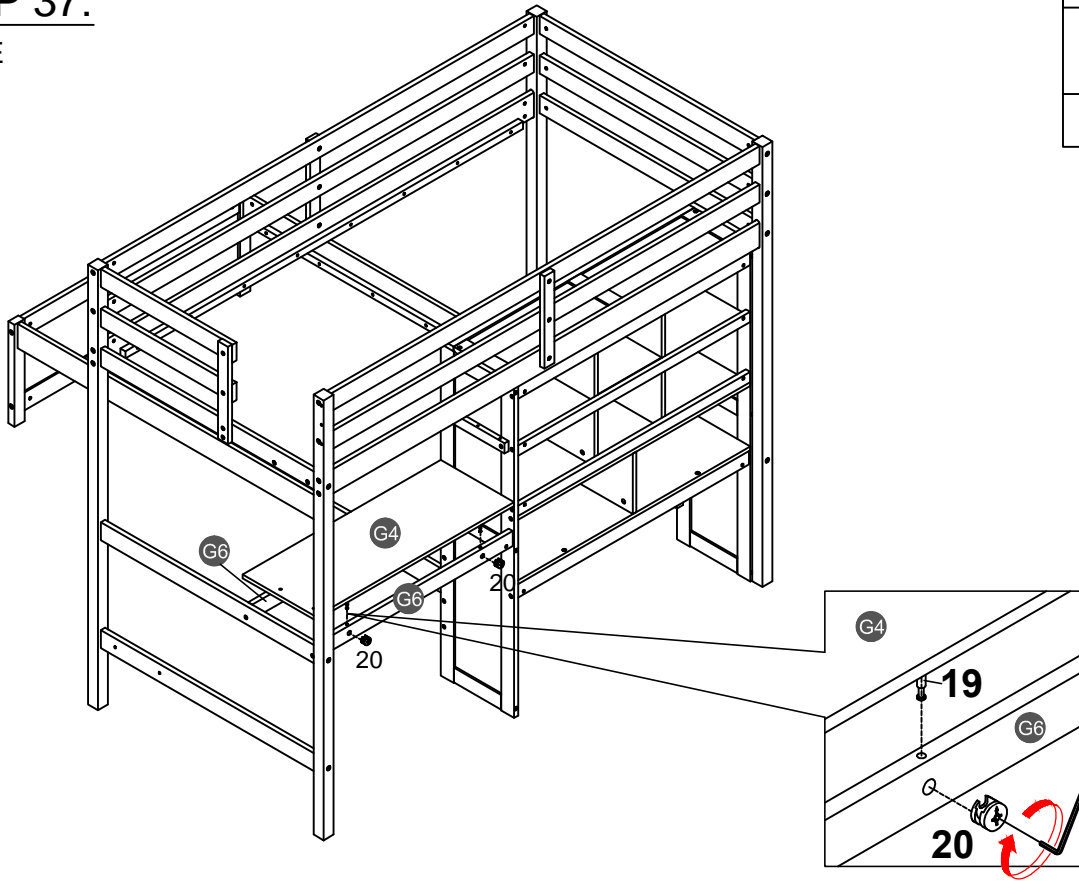

STEP 38:

ÉTAPE

5



2PCS

7



2PCS

8



2PCS

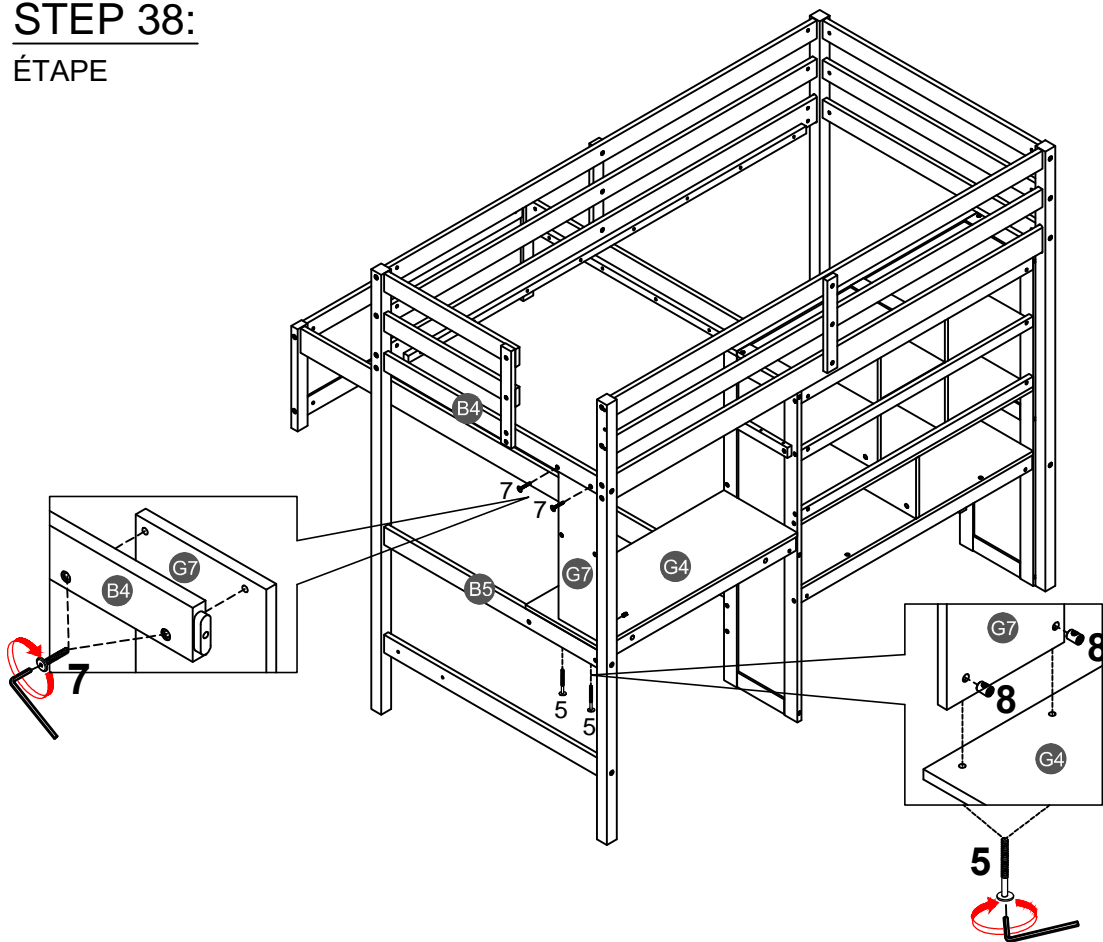

STEP 39:

ÉTAPE

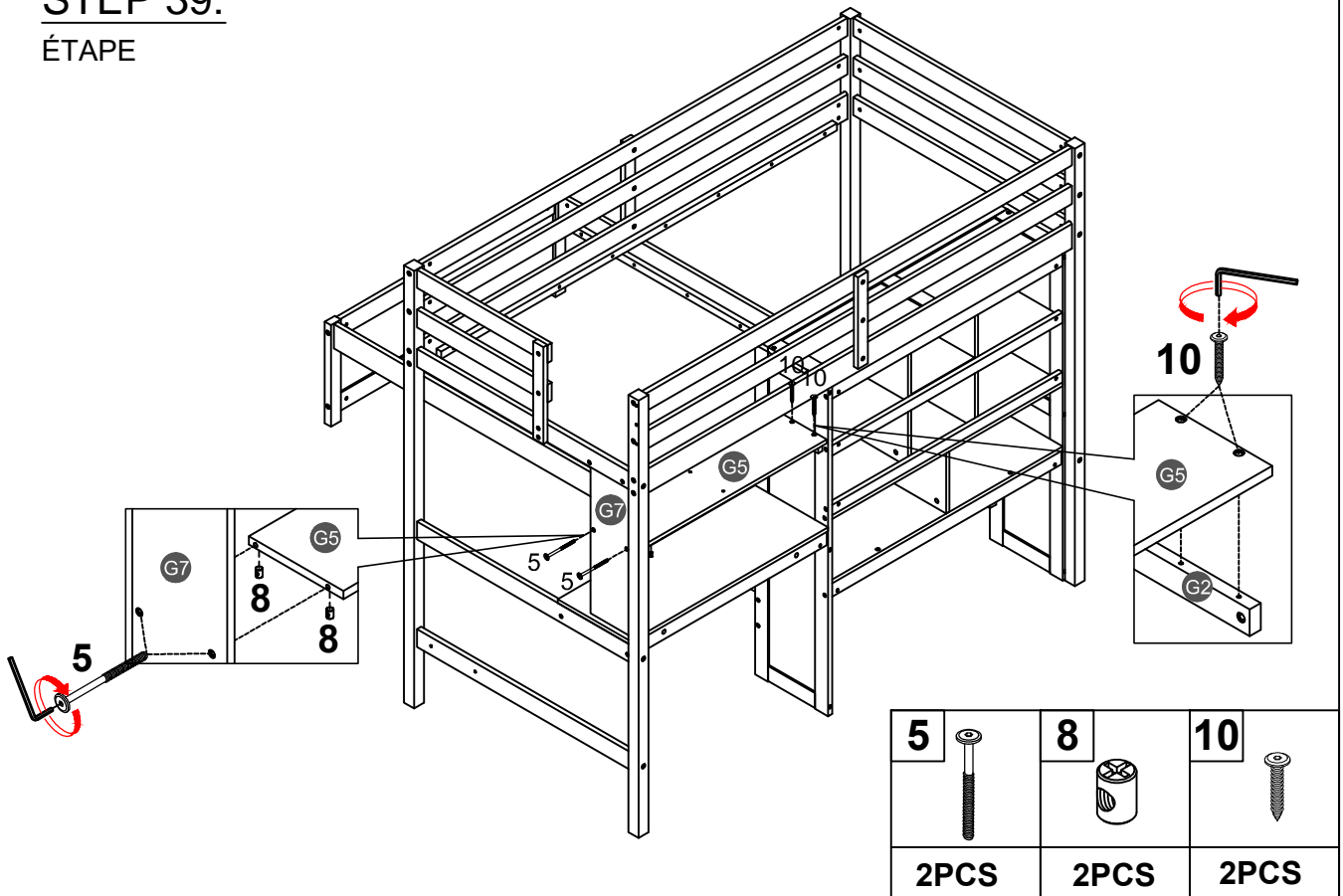

STEP 40:

ÉTAPE

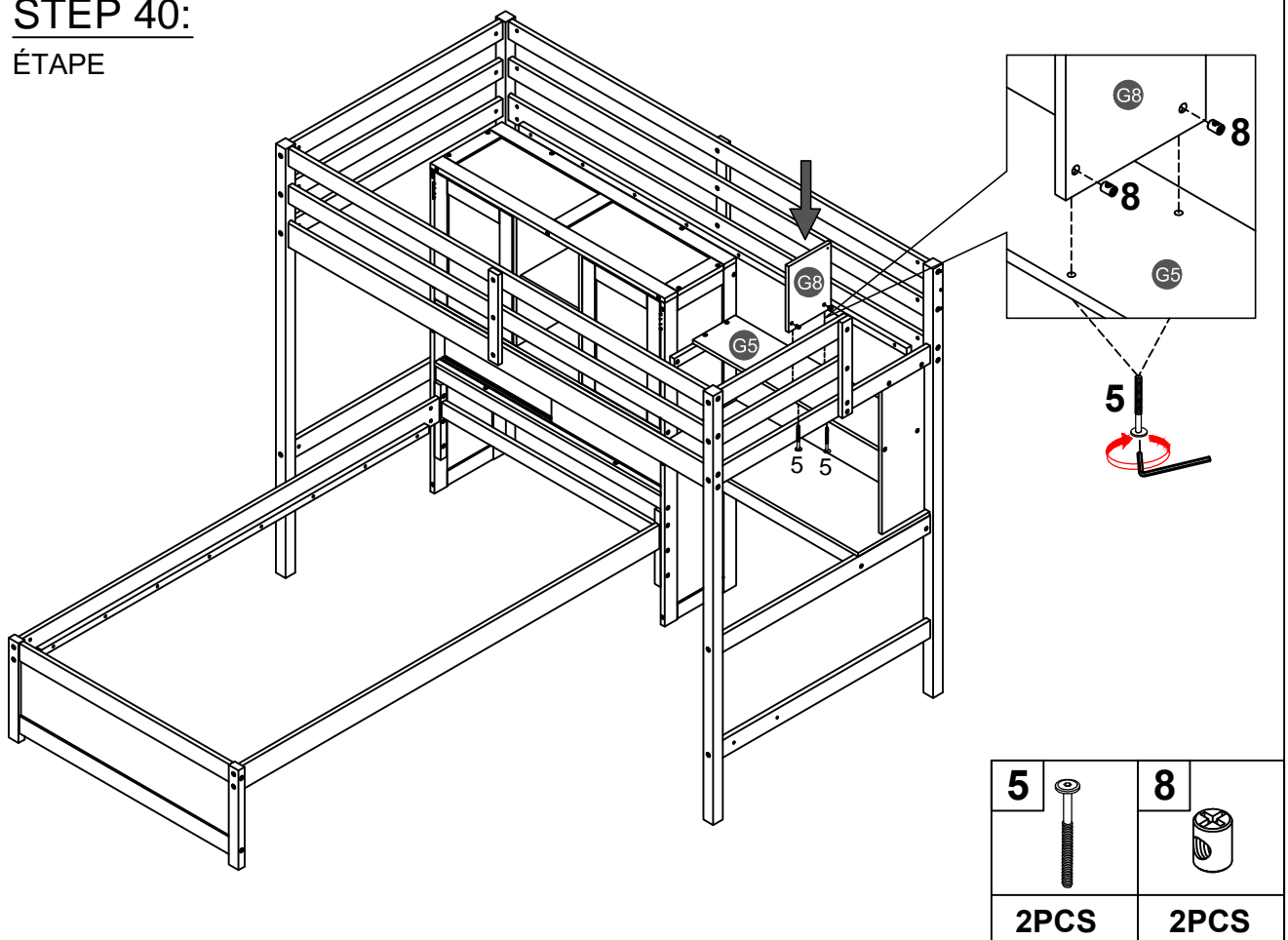

STEP 41:

ÉTAPE

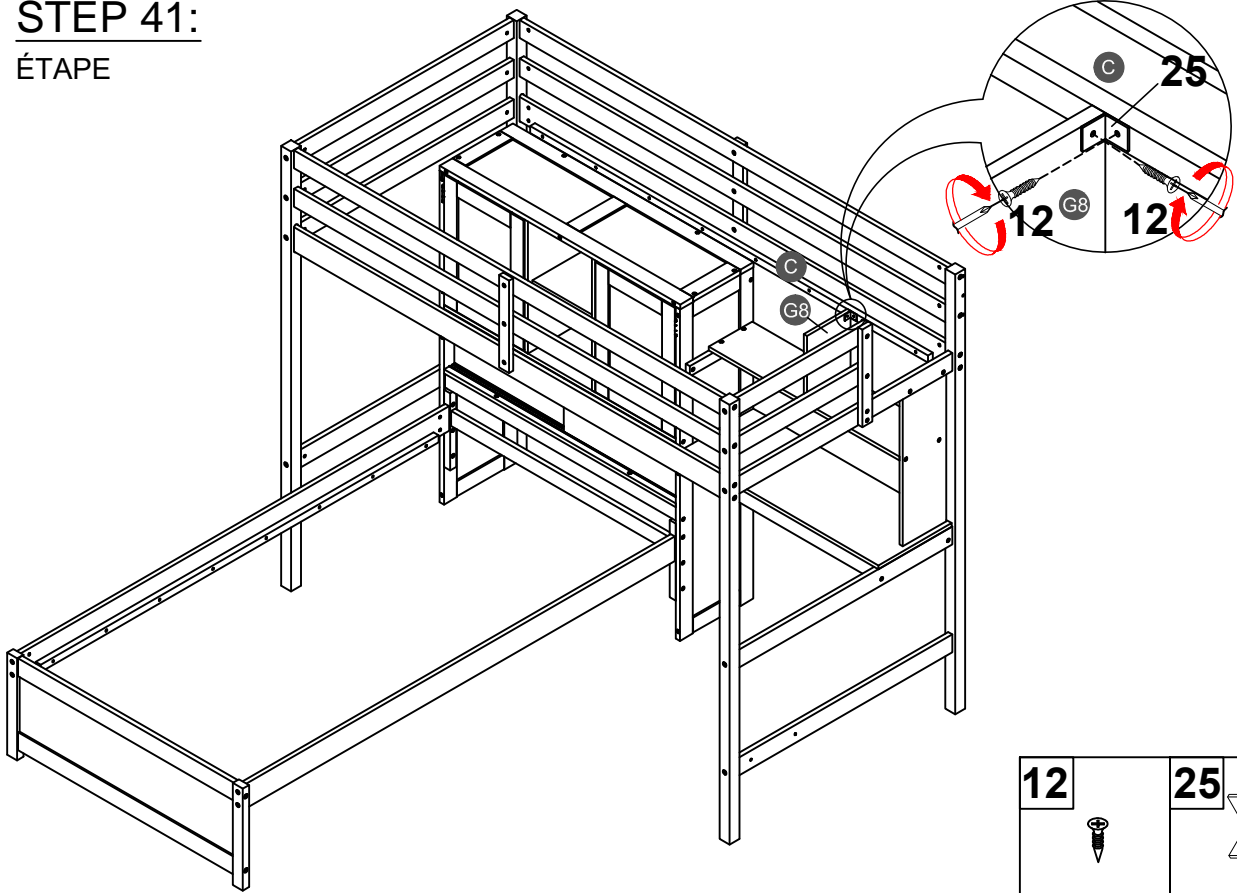

12 🔩	25 📐
2PCS	1PC

STEP 42:

ÉTAPE

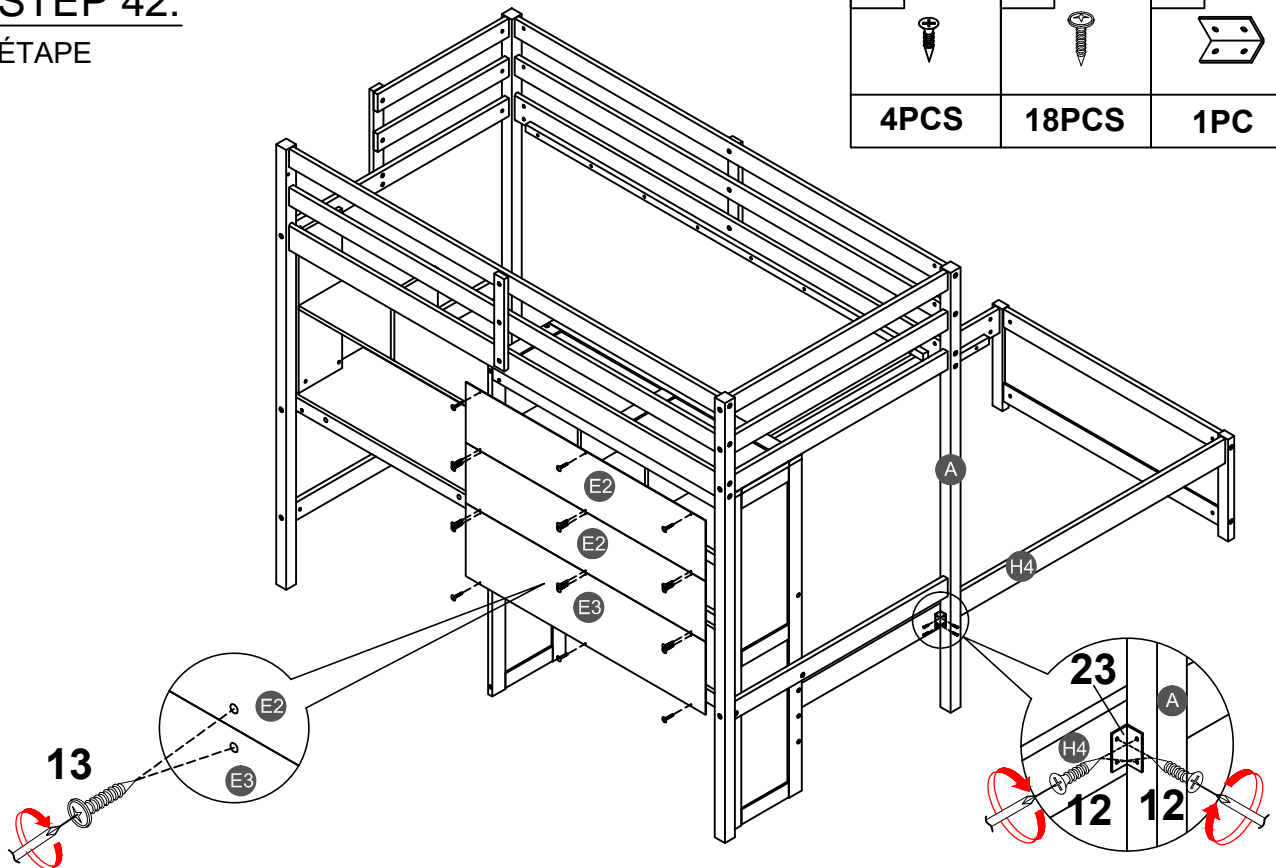

12 🔩	13 🔩	23 📐
4PCS	18PCS	1PC

Detail View

Vue Détaillée

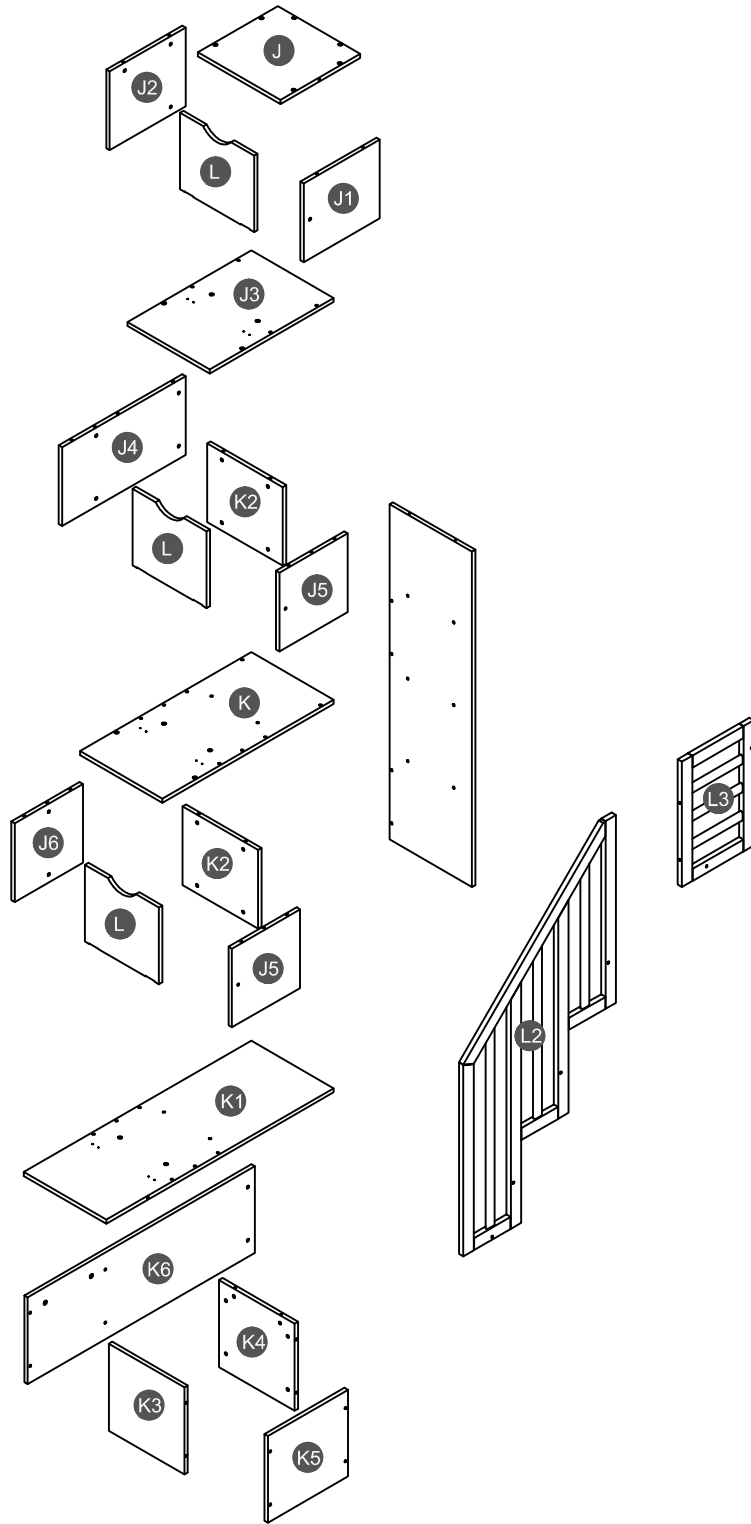

STEP 43:

ÉTAPE

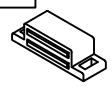
12		16	
2PCS		1PC	

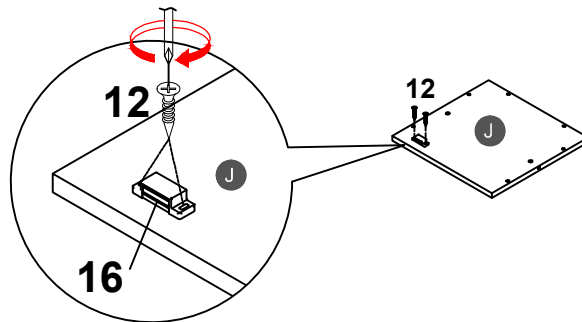

STEP 44:

ÉTAPE

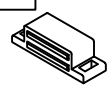
12		16	
2PCS		1PC	

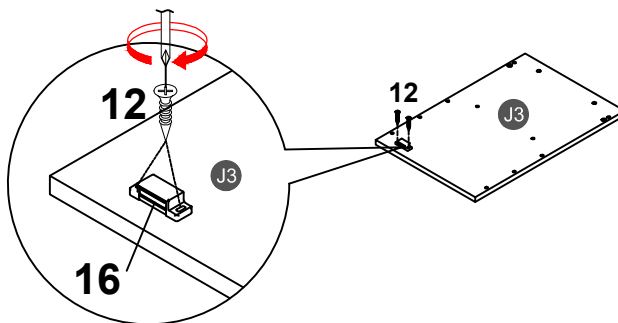

STEP 45:

ÉTAPE

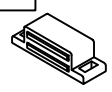

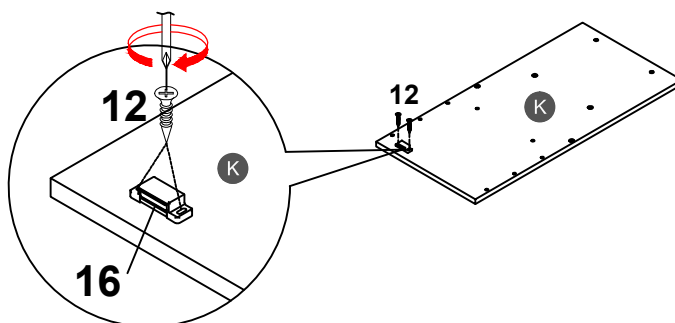
12		16	
2PCS		1PC	

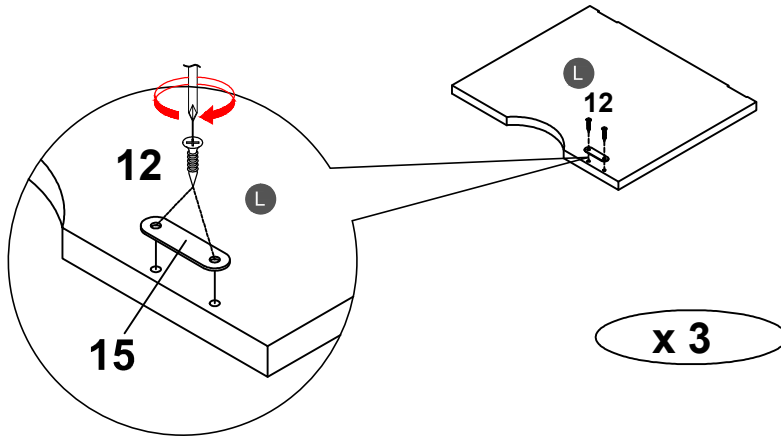

STEP 46:

ÉTAPE





12		15	
6PCS		3PCS	

STEP 47:

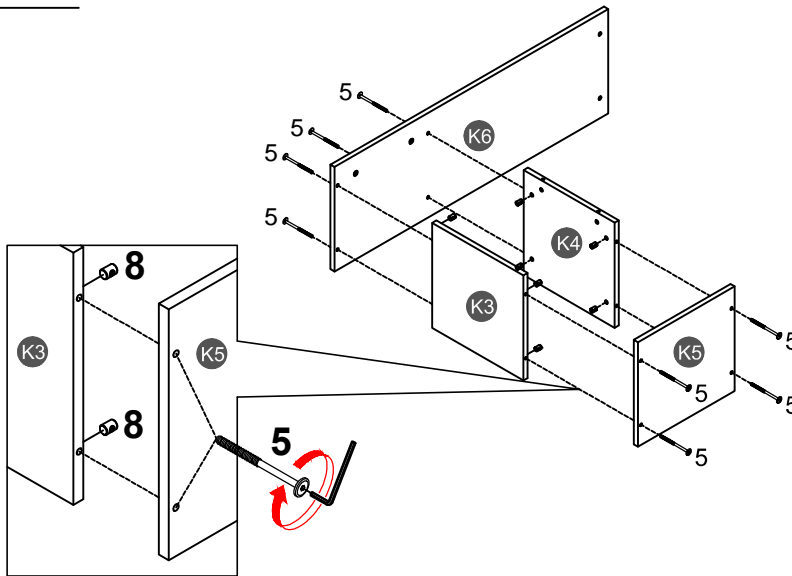
ÉTAPE





5		8	
8PCS		8PCS	

STEP 48:

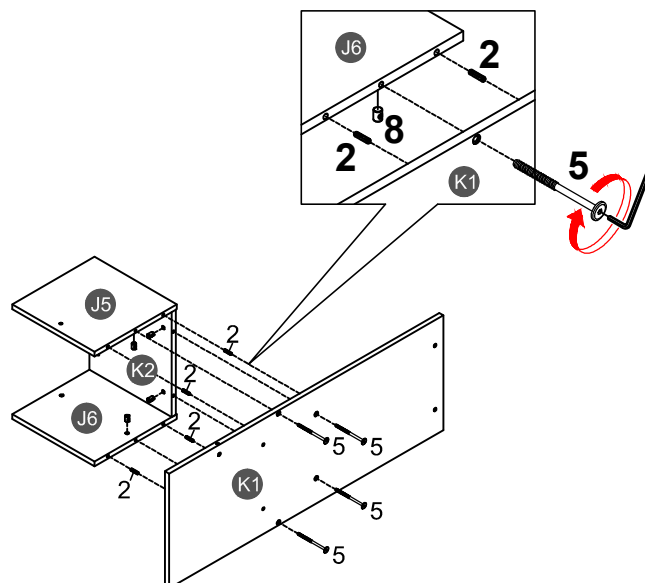
ÉTAPE





2	
4PCS	
5	
4PCS	
8	
4PCS	

STEP 49:

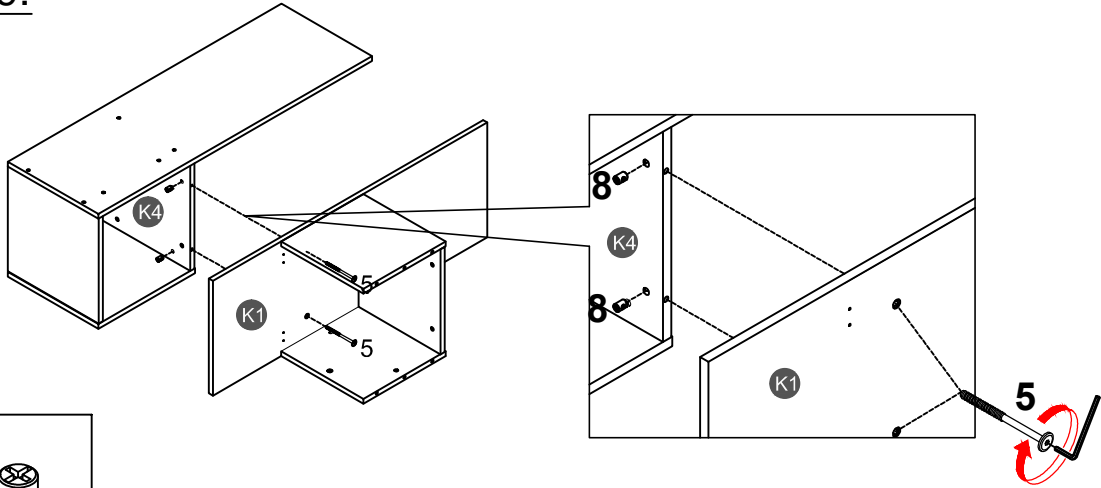
ÉTAPE





5		8	
2PCS		2PCS	

STEP 50:

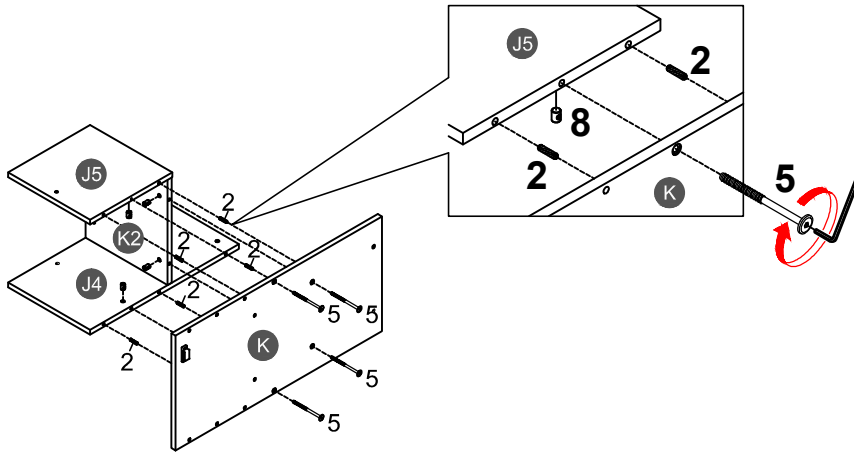
ÉTAPE





2	
5PCS	
5	
4PCS	
8	
4PCS	

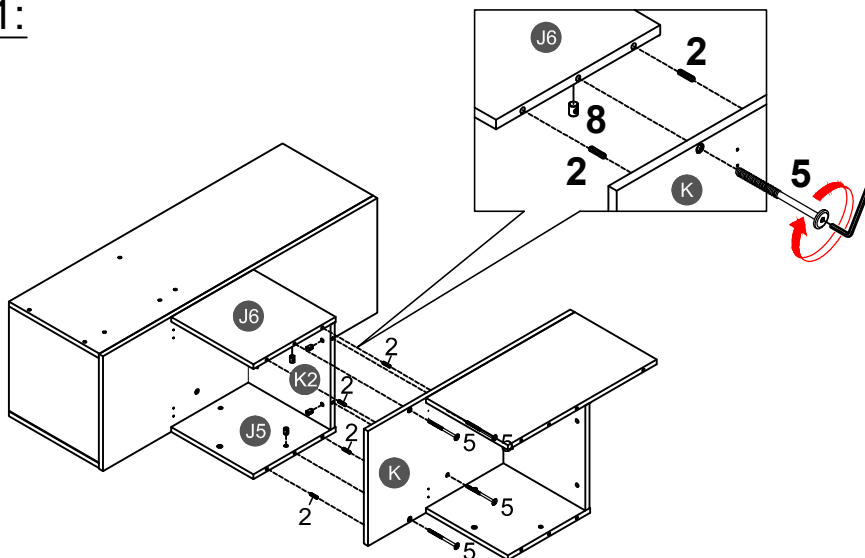

STEP 51:

ÉTAPE





2	
4PCS	
5	
4PCS	
8	
4PCS	

STEP 52:
ÉTAPE

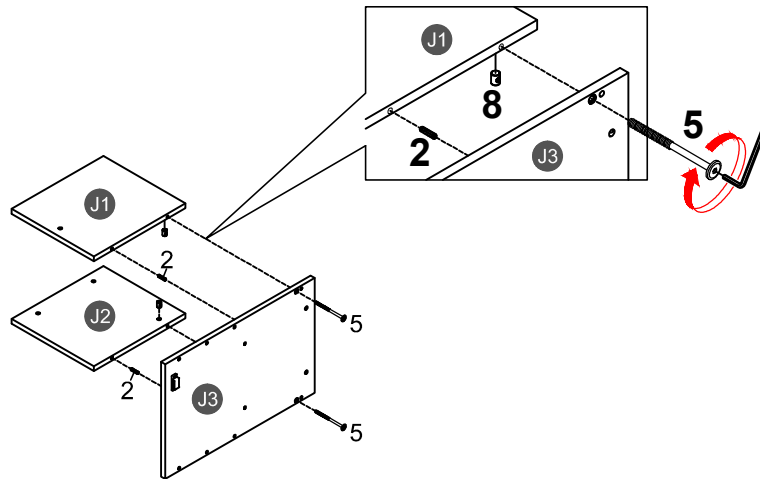
2		5		8	
2PCS		2PCS		2PCS	



STEP 53:
ÉTAPE

5		8	
4PCS		4PCS	

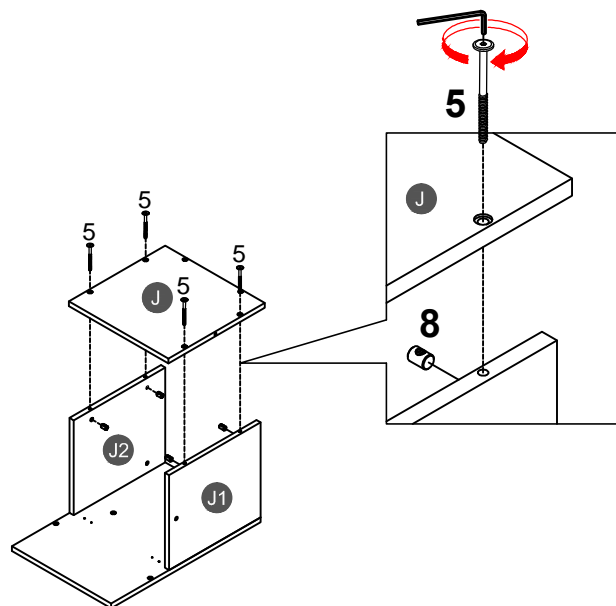

STEP 54:

ÉTAPE

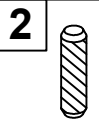
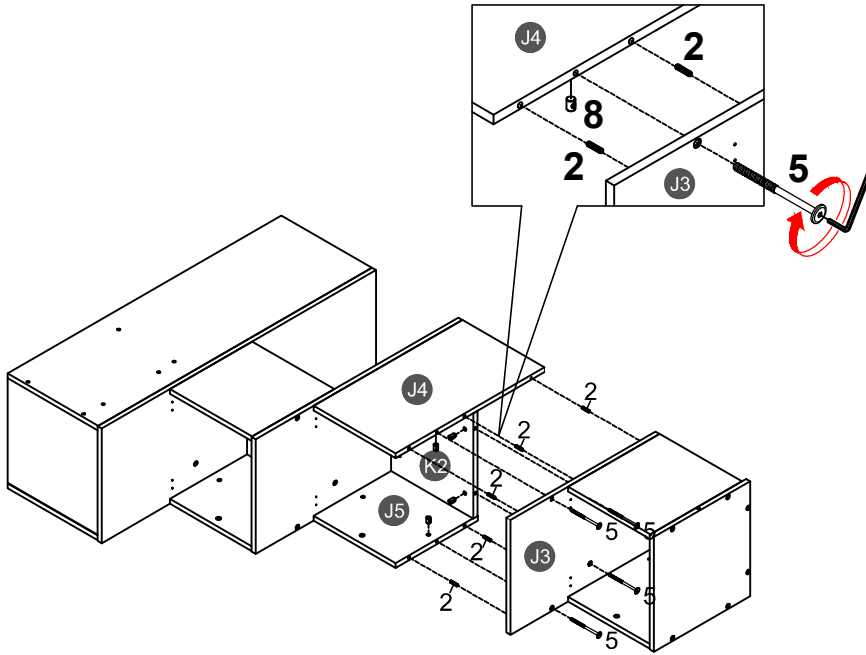

5PCS

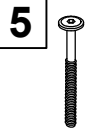

4PCS

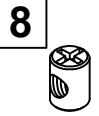

4PCS

STEP 55:

ÉTAPE

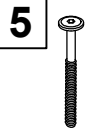
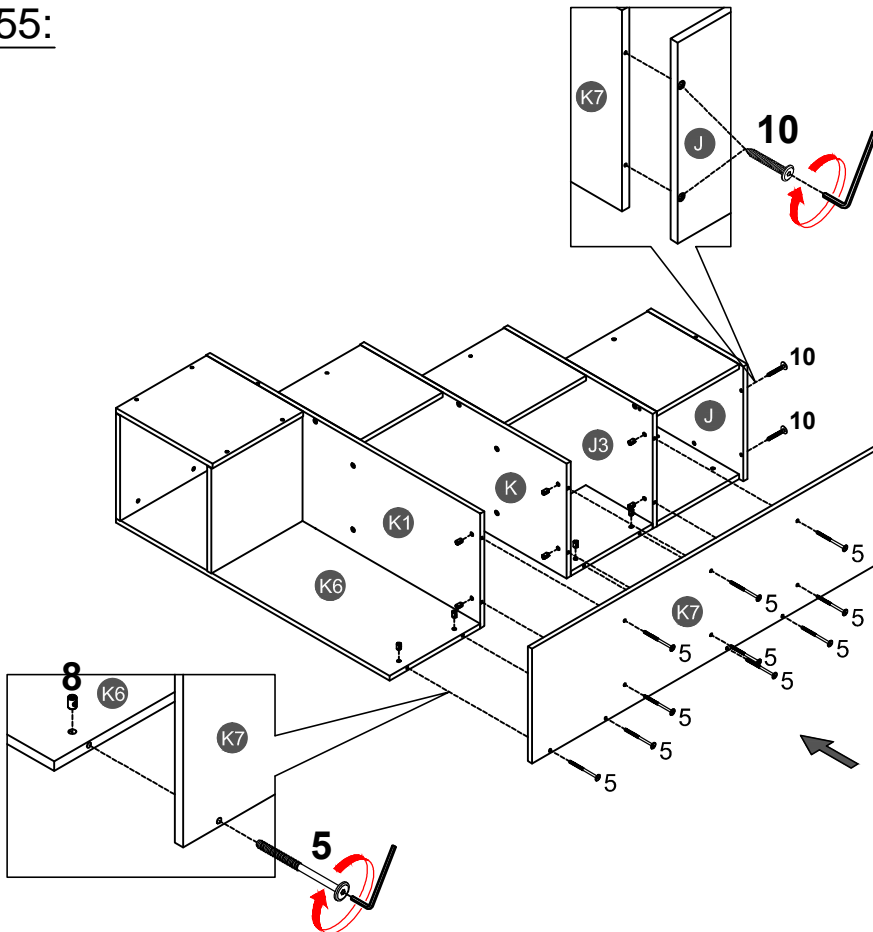

10PCS

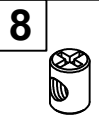

10PCS

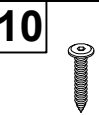

2PCS

STEP 56:

ÉTAPE

5



2PCS

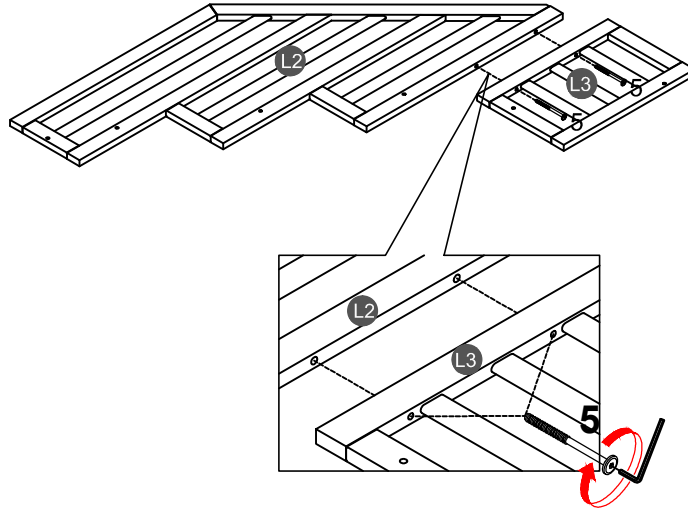

STEP 57:

ÉTAPE

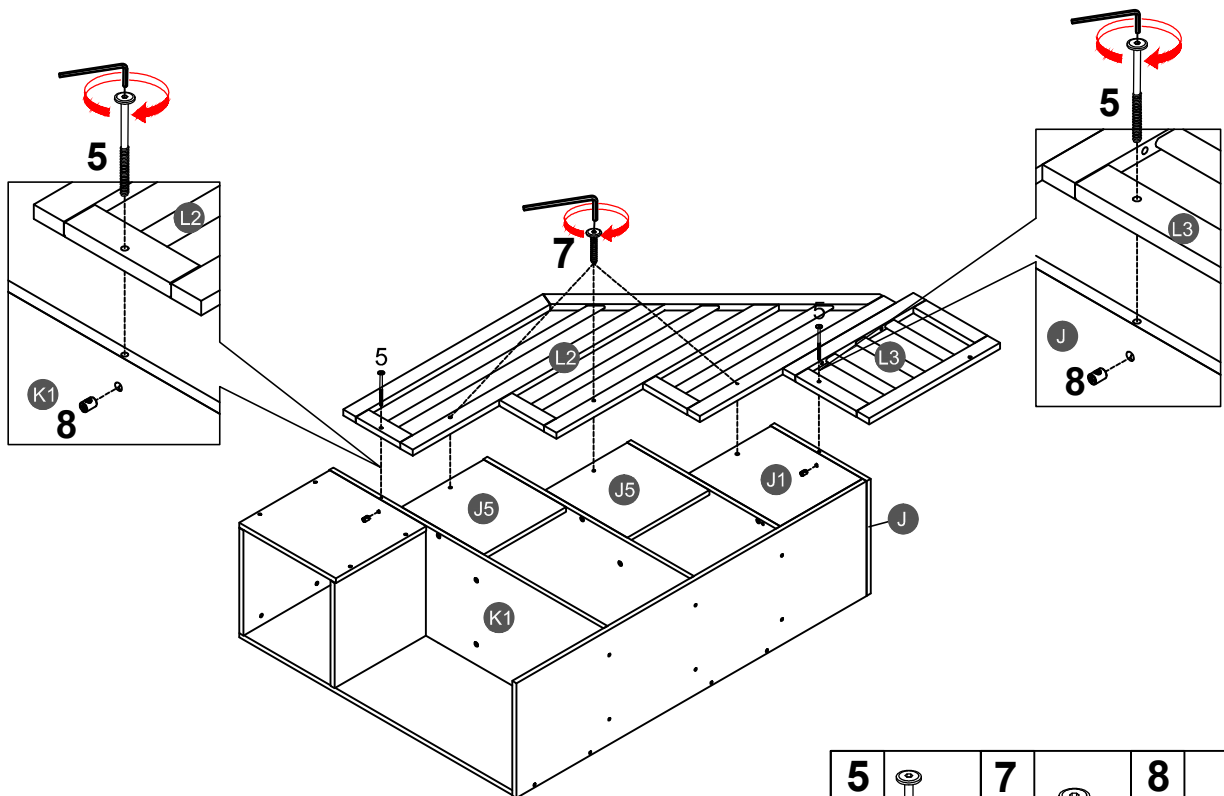

5



2PCS

7



3PCS

8



2PCS

STEP 58:

ÉTAPE

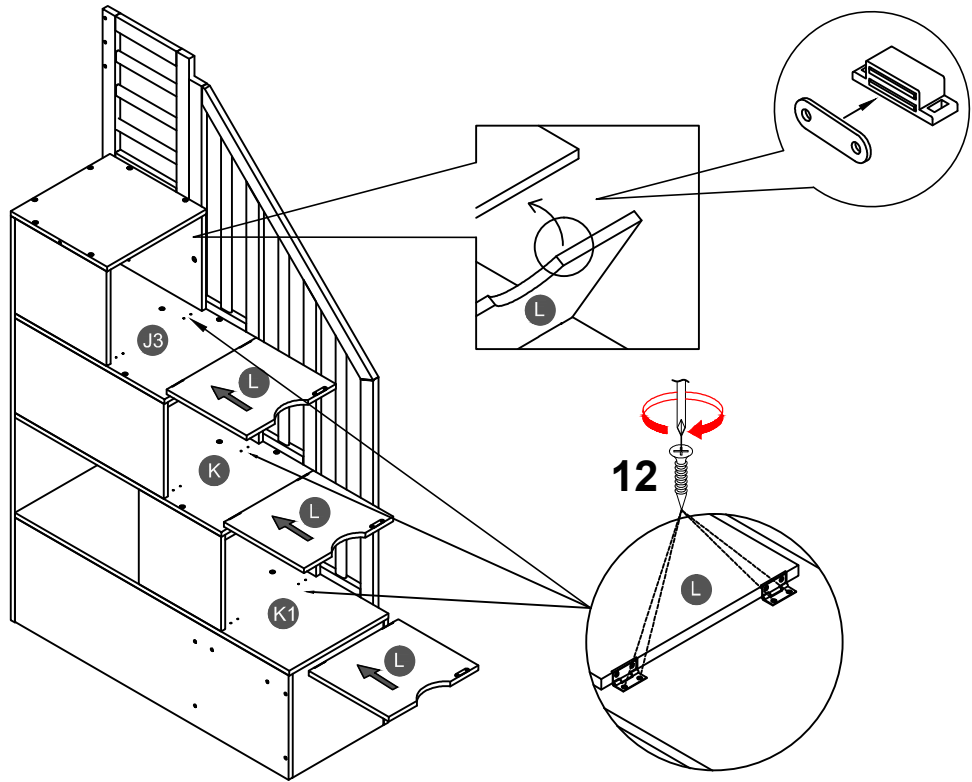

12



12PCS

STEP 59:

ÉTAPE



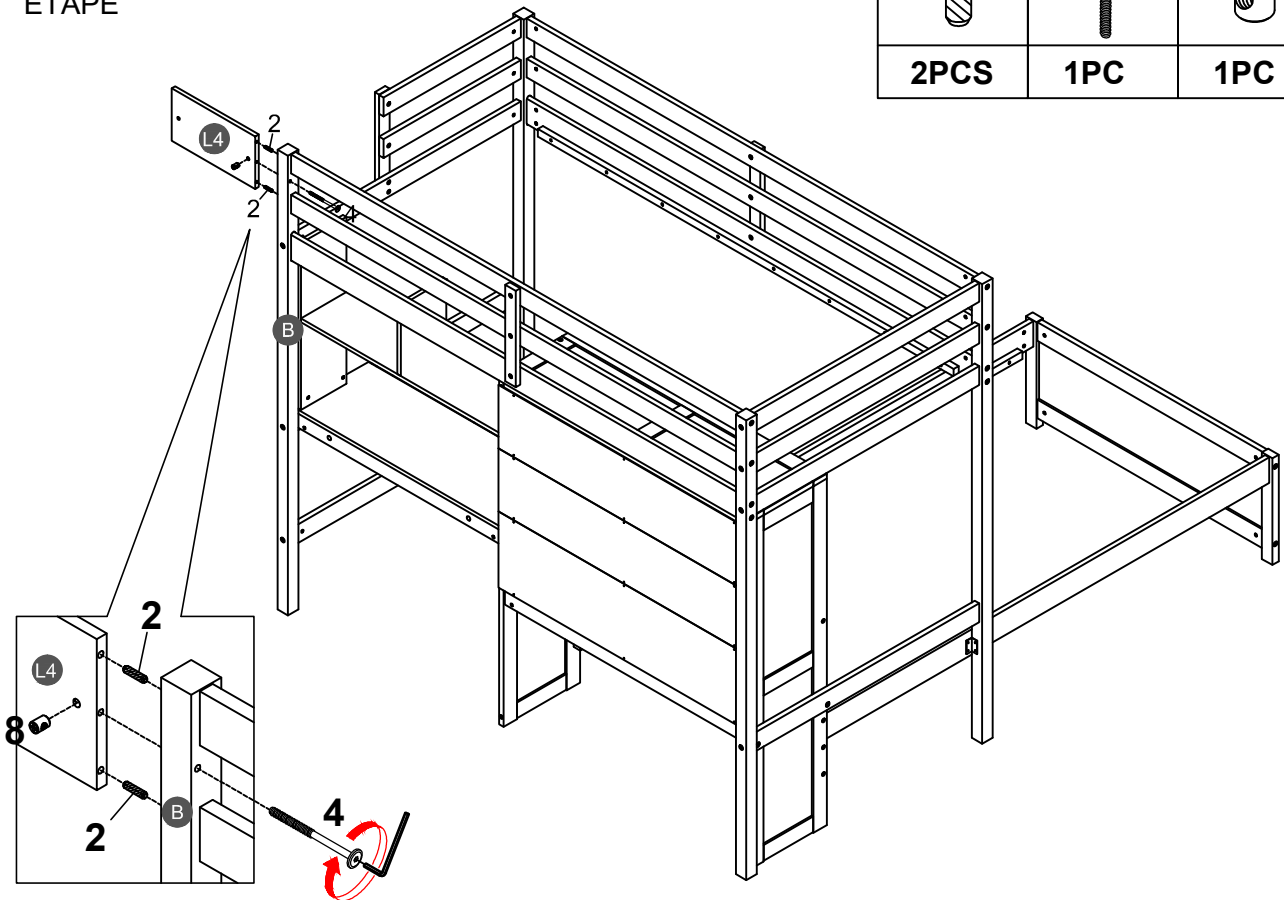

2		4		8	
2PCS		1PC		1PC	

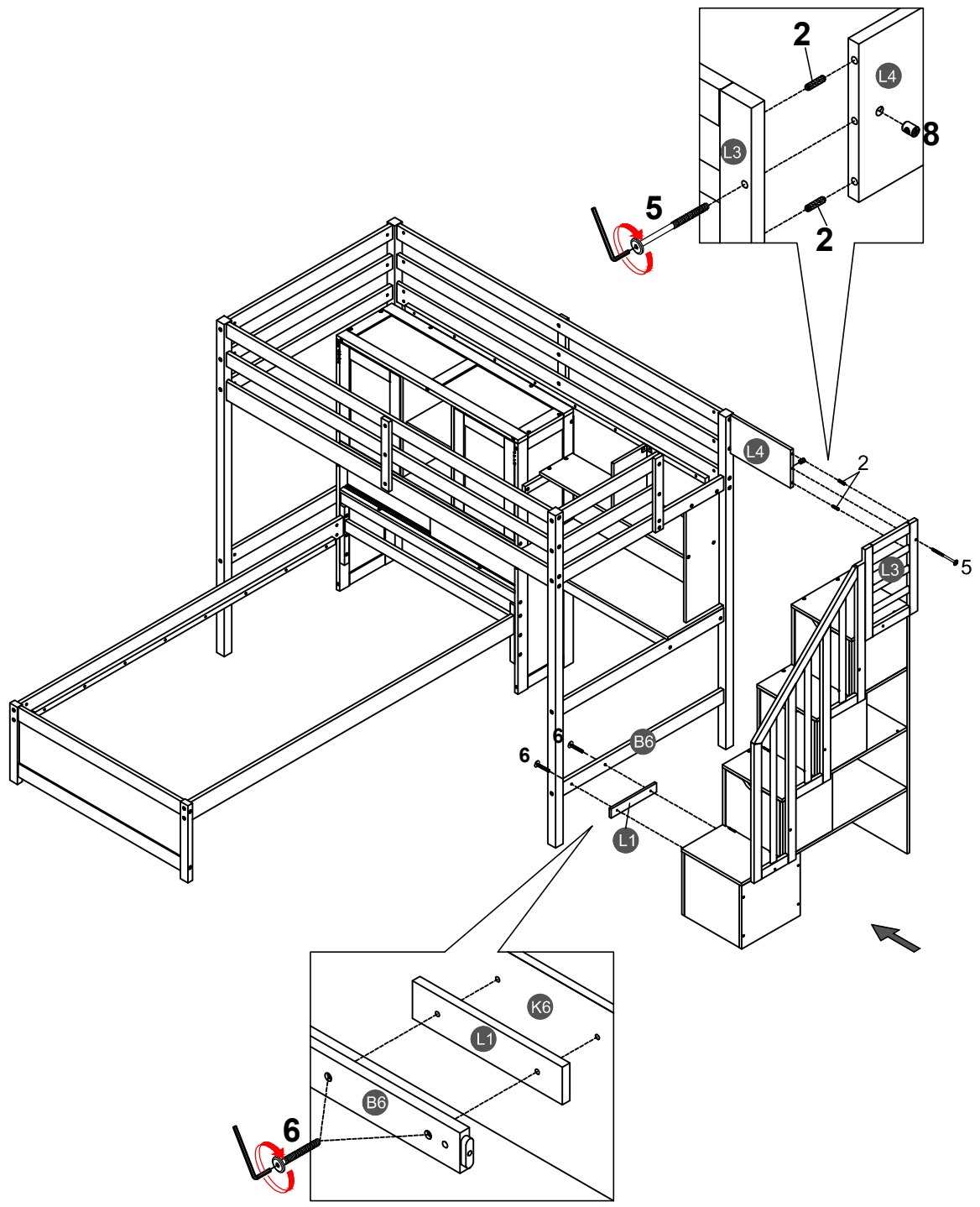

STEP 60:



ÉTAPE



2		5		6		8	
2PCS		1PC		2PCS		1PC	

STEP 61:

ÉTAPE

12	24
	
8PCS	2PCS

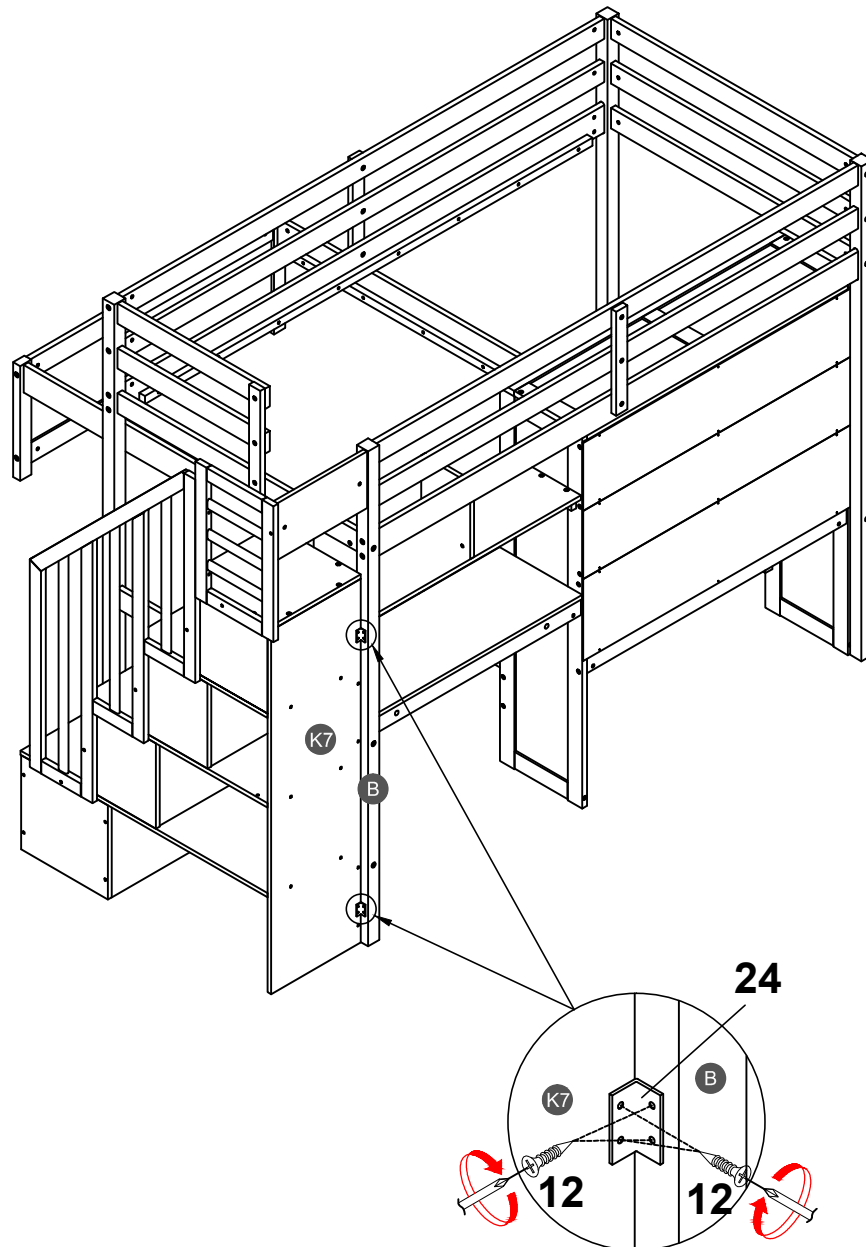

STEP 62:

ÉTAPE

11



42PCS

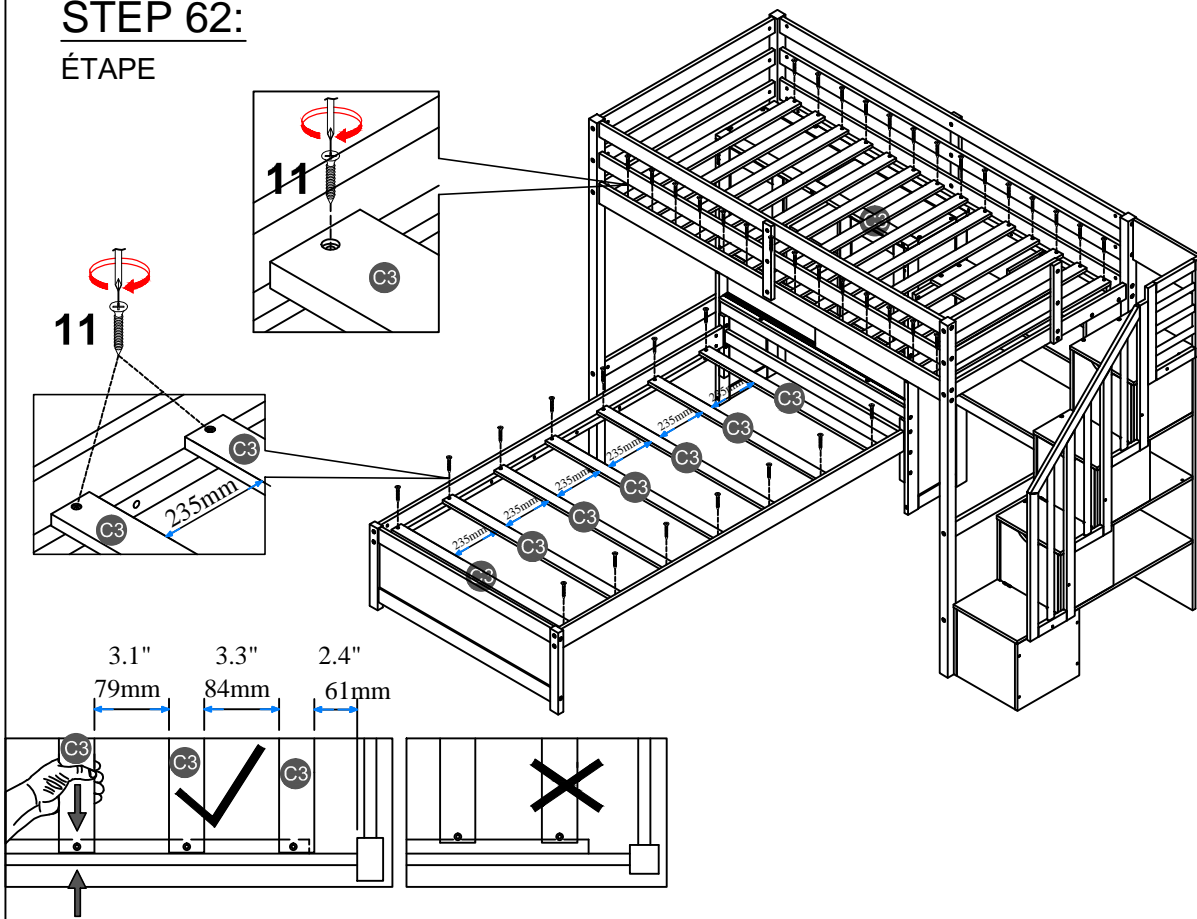

NOTE: Please make sure the bed slats close to the side rail before locking the screws to avoid breakage. This step is required for both the left and right sides. Moreover, please do not lock the screws of the bed slats at the outermost edge to avoid damaging.

Remarque: Assurez-vous Les lattes du lit fermer du rail latéral avant de verrouiller les vis pour éviter la casse. Cette étape est requise pour tous les deux côtés gauche et droit. De plus, ne verrouillez pas les vis des lattes de lit sur le bord le plus extérieur pour éviter d'endommager.

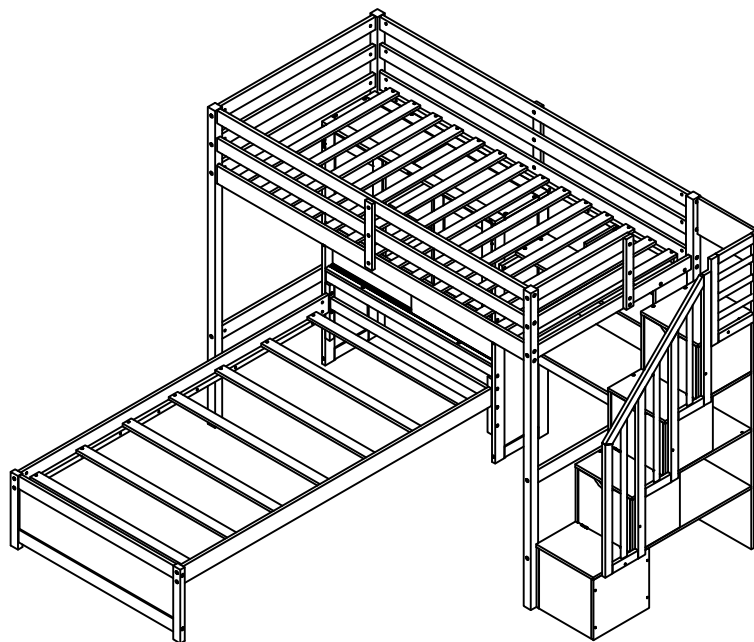

Make sure to tighten all the screws of the bed.

Assurez-vous de serrer toutes les vis des de lit.