

ASSEMBLY INSTRUCTIONS

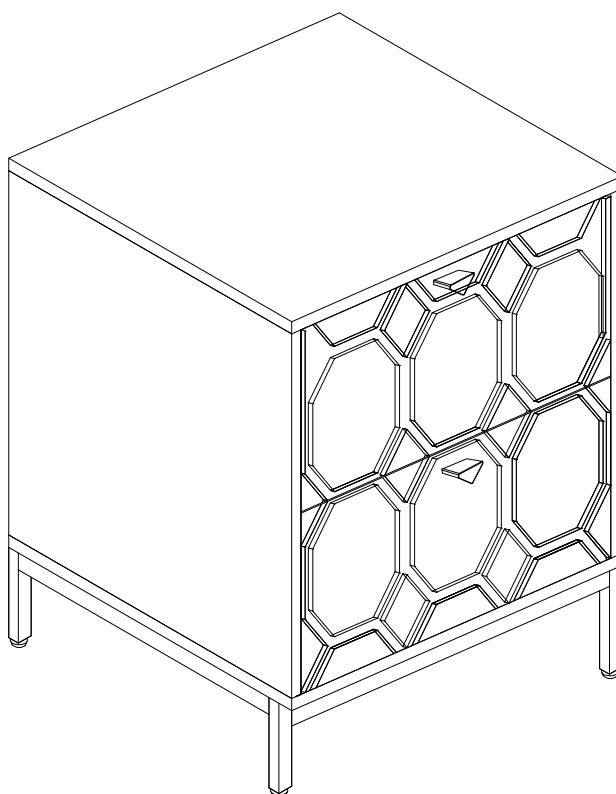

WARNING:



TIPPING HAZARD. This cabinet can tip over if not secured, causing serious injury or death. Always attach to the wall using the safety wall strap (Part I) provided. Never allow children to climb on drawers or use them as steps.

ASSEMBLY INSTRUCTIONS

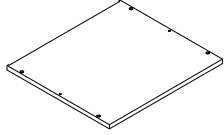
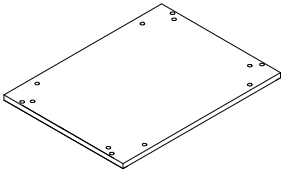
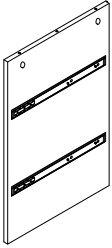
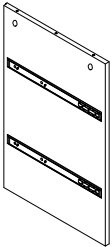
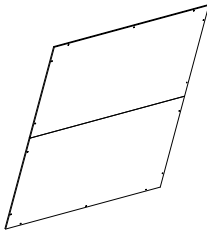
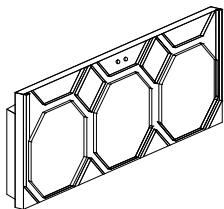
Part list:



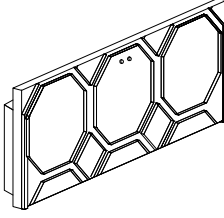

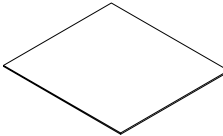
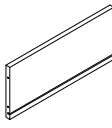
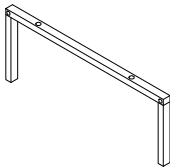
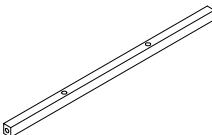

ITEM	DESCRIPTION	PART	QTY
1	Top panel		1
2	Bottom panel		1
3	Left side panel		1
4	Right side panel		1
5	Back panel		1
6	Upper drawer surface		1

Part list:

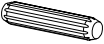





ITEM	DESCRIPTION	PART	QTY
7	Lower drawer surface		1
8	Drawer left side		2
9	Drawer right side		2
10	Drawer bottom		2
11	Drawer back		2
12	Side leg		2
13	Crossbar		2

ASSEMBLY INSTRUCTIONS

Hardware List:

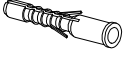
ITEM	DESCRIPTION	PART	QTY
A	Wooden dowel	 Φ0.31*1.18"	4
B	Bolt	 Φ0.23*1.18"	8
C	Allen wrench		1
D	Handle		2
E	Machine screw	 Φ0.15*0.7"	4
F	Back screw	 Φ0.11*0.55"	14
G	Bolt	 Φ0.23*1.57"	4

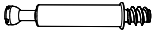
Hardware List:

ITEM	DESCRIPTION	PART	QTY
H	Grub screw	 Φ0.15*1.37"	20
I	Safety wall strap		1
J	Plastic anchor		1
K	Mounting screw	 Φ0.15*1.57"	1
L	Washer		1
M	Camlock bolt		4
N	Camlock		4

- * Required screwdriver & mallet, not included.
- * Before discarding packing materials, please check to make sure that all parts and hardware is present.
- * Two people needed for assembly.
- * Please follow the instructions closely; Do not over-tighten screws or bolts unless specified.
- * After a few days from initial assembly, the product may adjust to the environment. Please retighten the hardware.

Guideline For Assembling of Cam Lock (M & N)

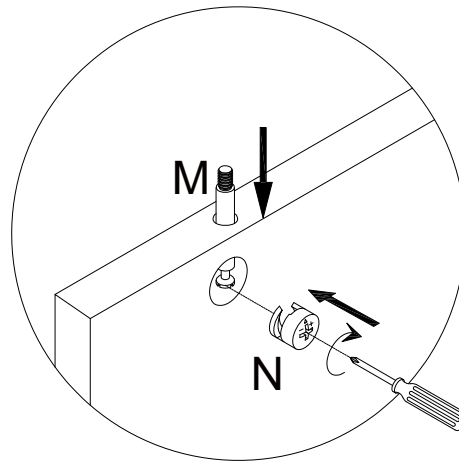
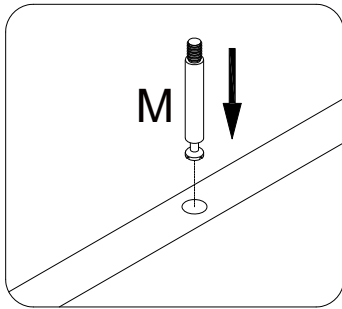



Screw camlock bolt (M) to wood part.

Do not assemble camlock (N) unless instructed.

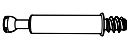

To assemble camlock (N), ensure long side of the + is facing the bolt (M) before inserting into hole.

STEP 1

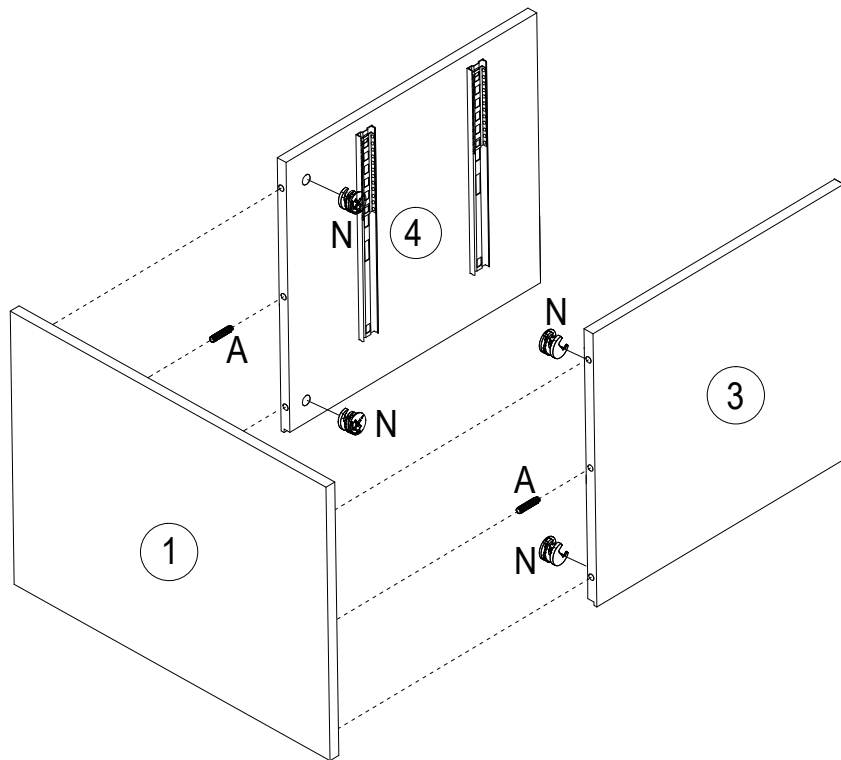
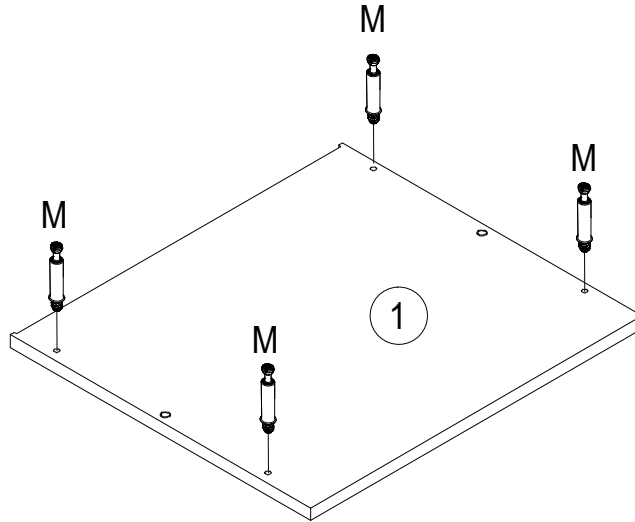
A:		2PCS
M:		4PCS
N:		4PCS



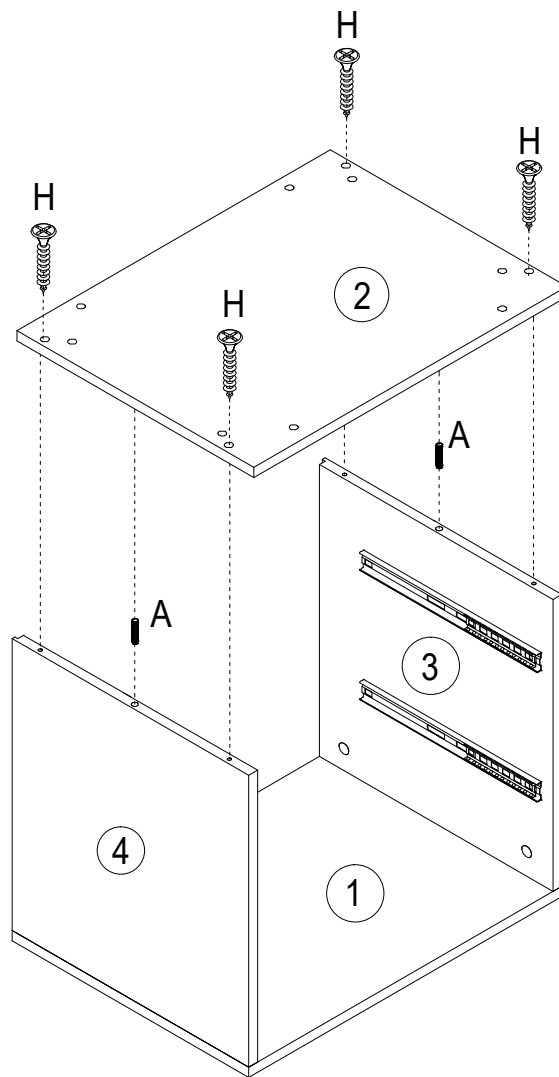

STEP 2

H:		4PCS
A:		4PCS



STEP 3

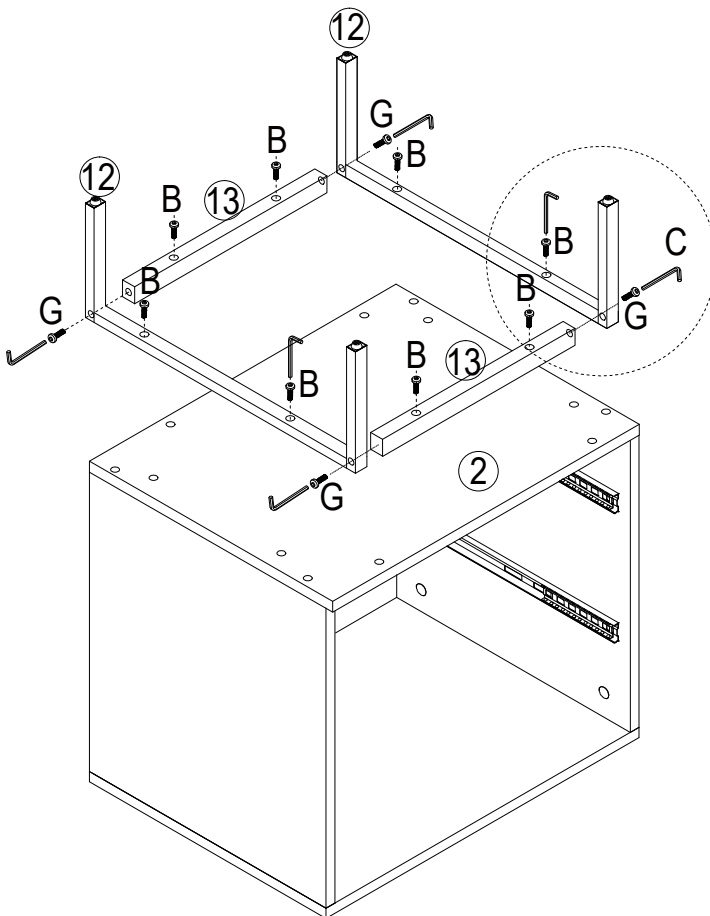

B:		8PCS
C:		1PC
G:		4PCS

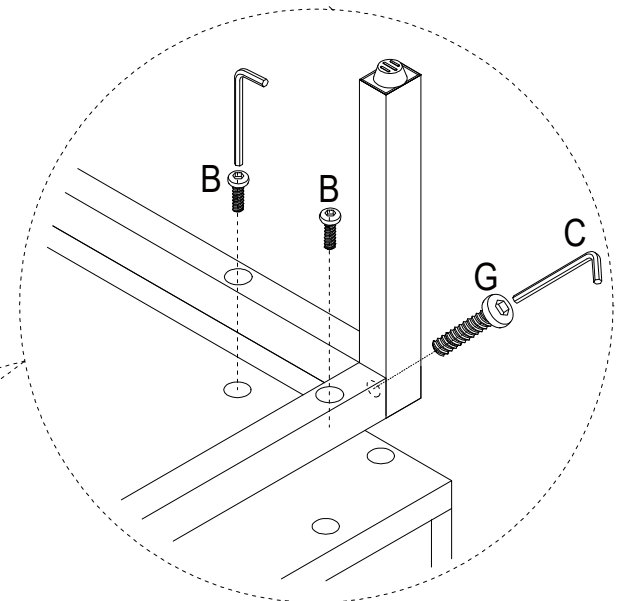

Please note that the length of B/Gnumber screw is different. Please use it correctly according to the instructions to avoid damaging the bottom panel!



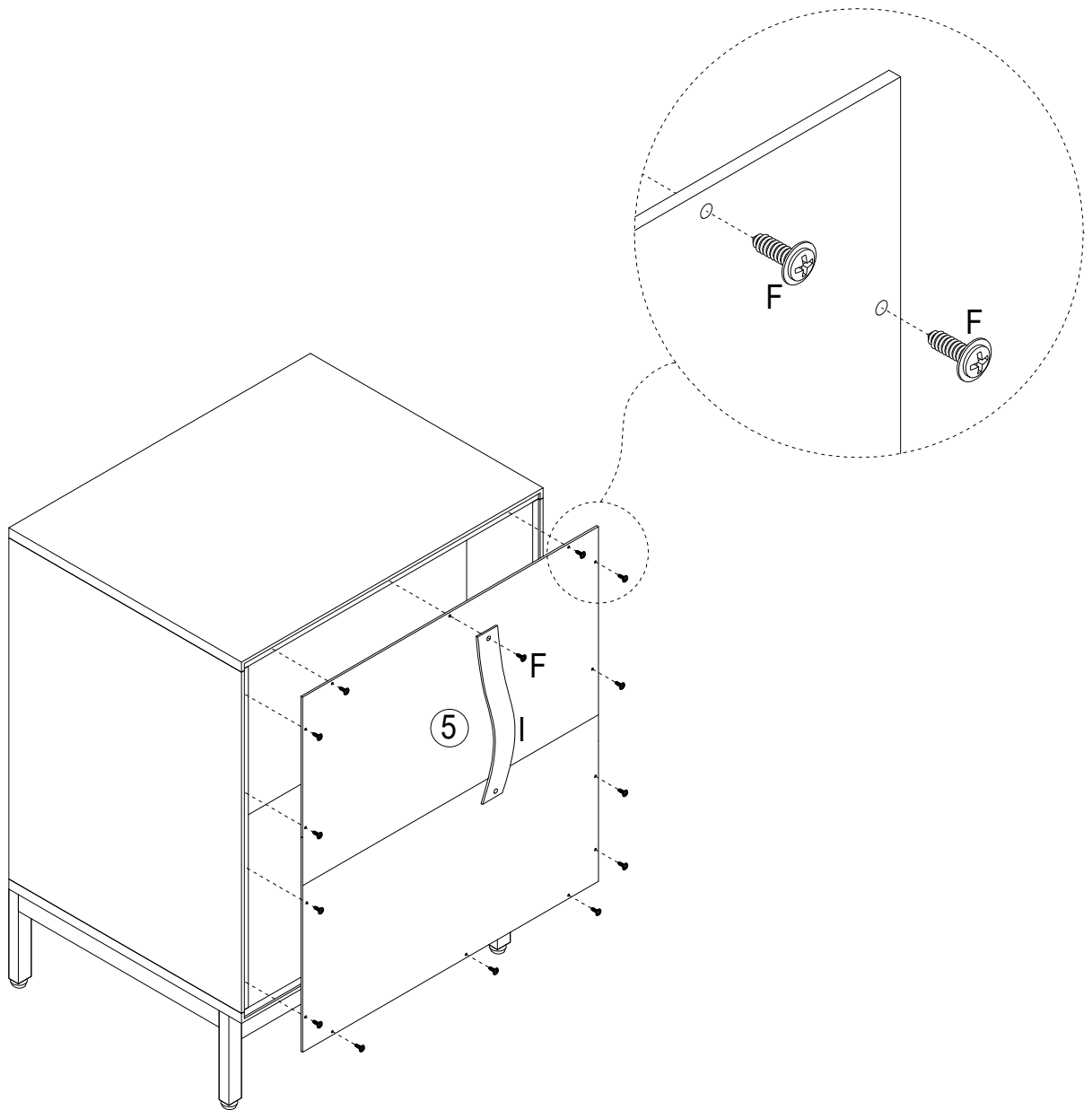

STEP 4

F:		14PCS
I:		1PC



STEP 5

H:		16PCS
D:		2PCS
E:		4PCS

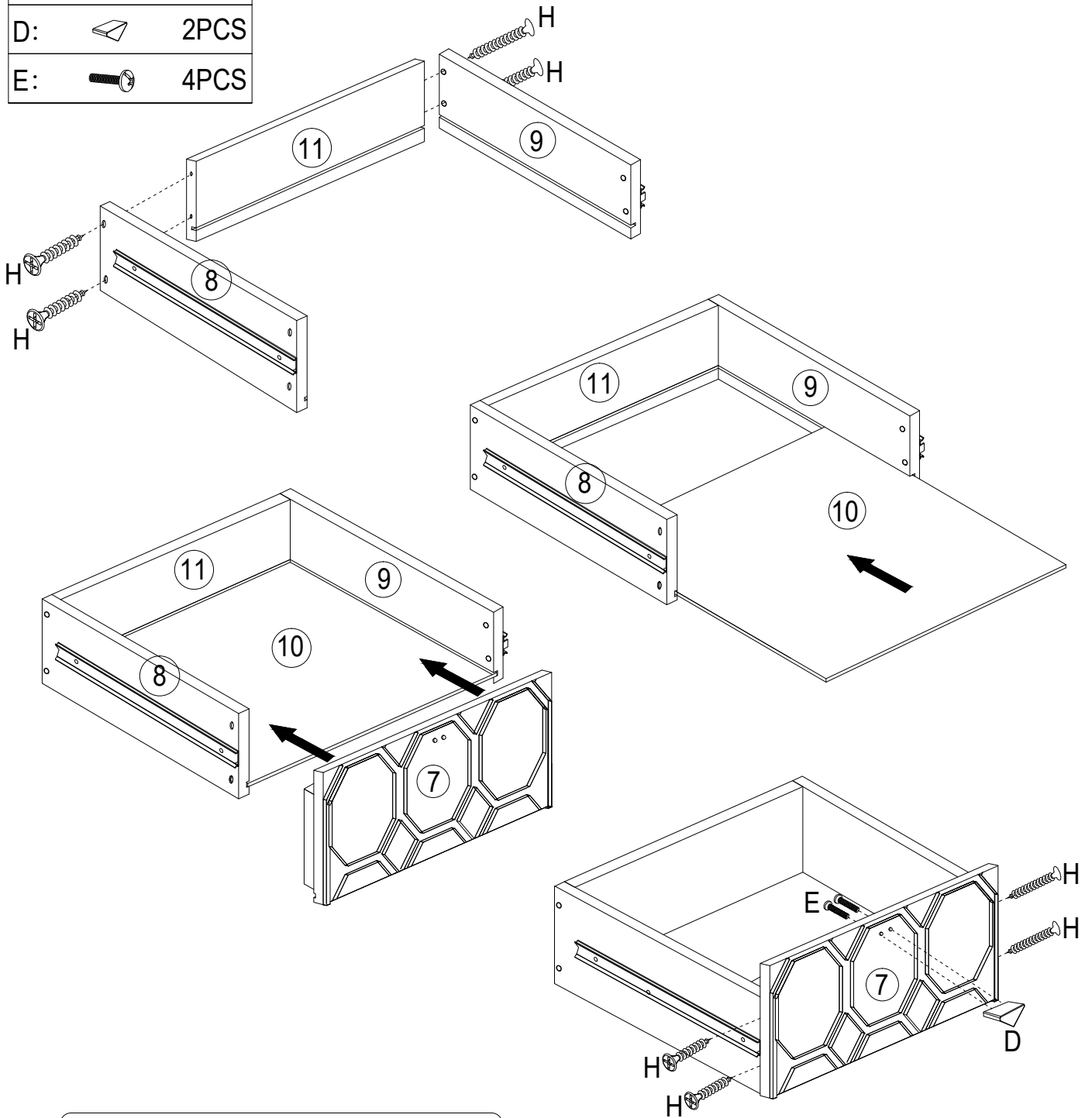

6 # and # drawers are assembled in the same way

STEP 6

Note: Extend the drawer slide rail to its front position before inserting the drawer into the cabinet.

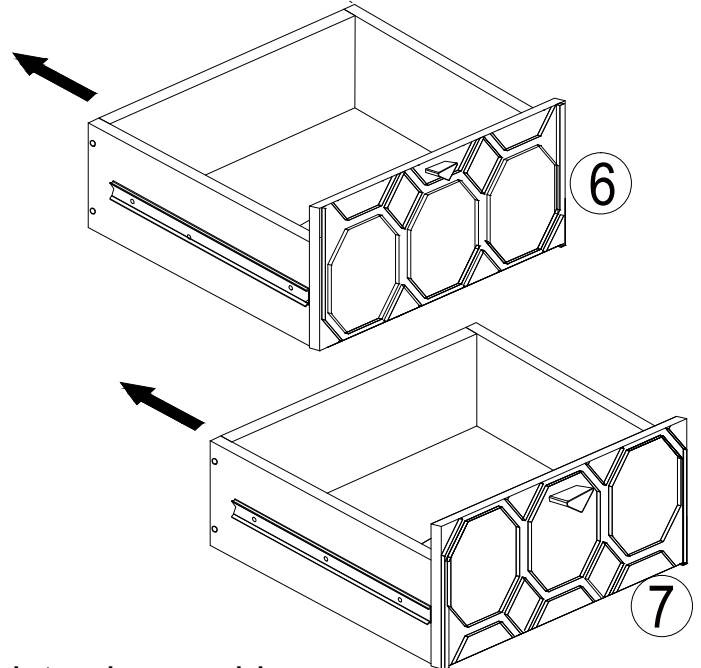
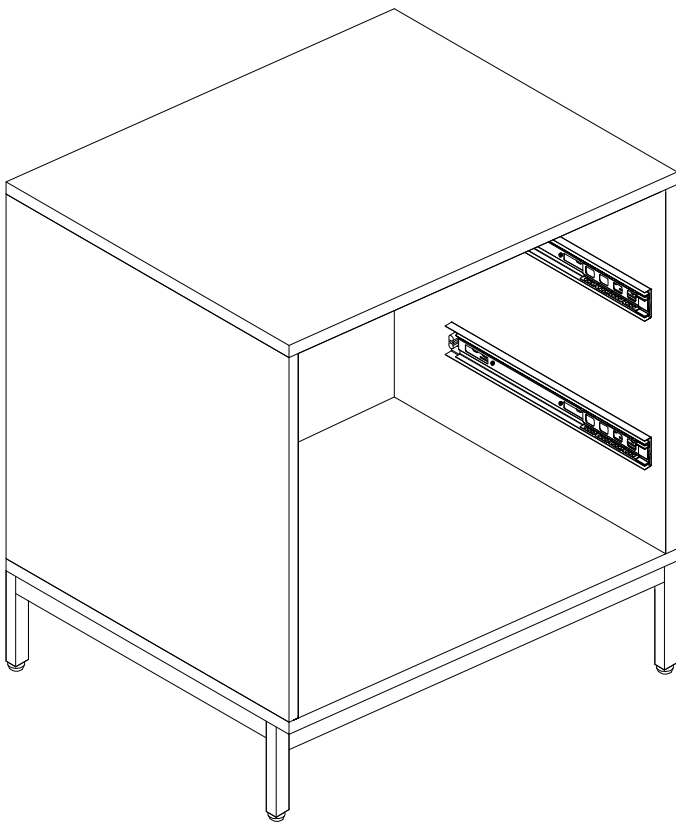
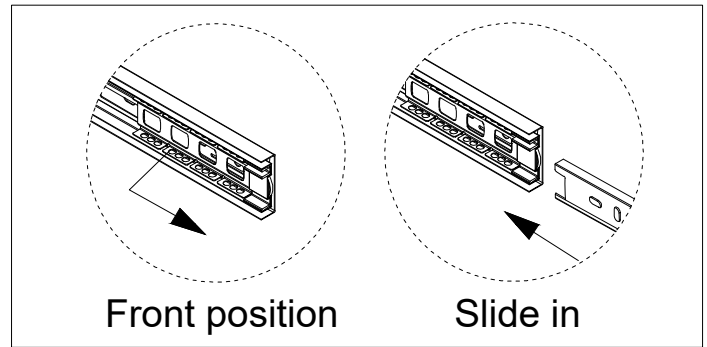

Reminder : If the front and both ends of the drawer are tilted, do not use force,
You can refer to the above steps to smoothly insert the slide rail.

Item 6 and 7 drawer front panels are not interchangeable.

STEP 7

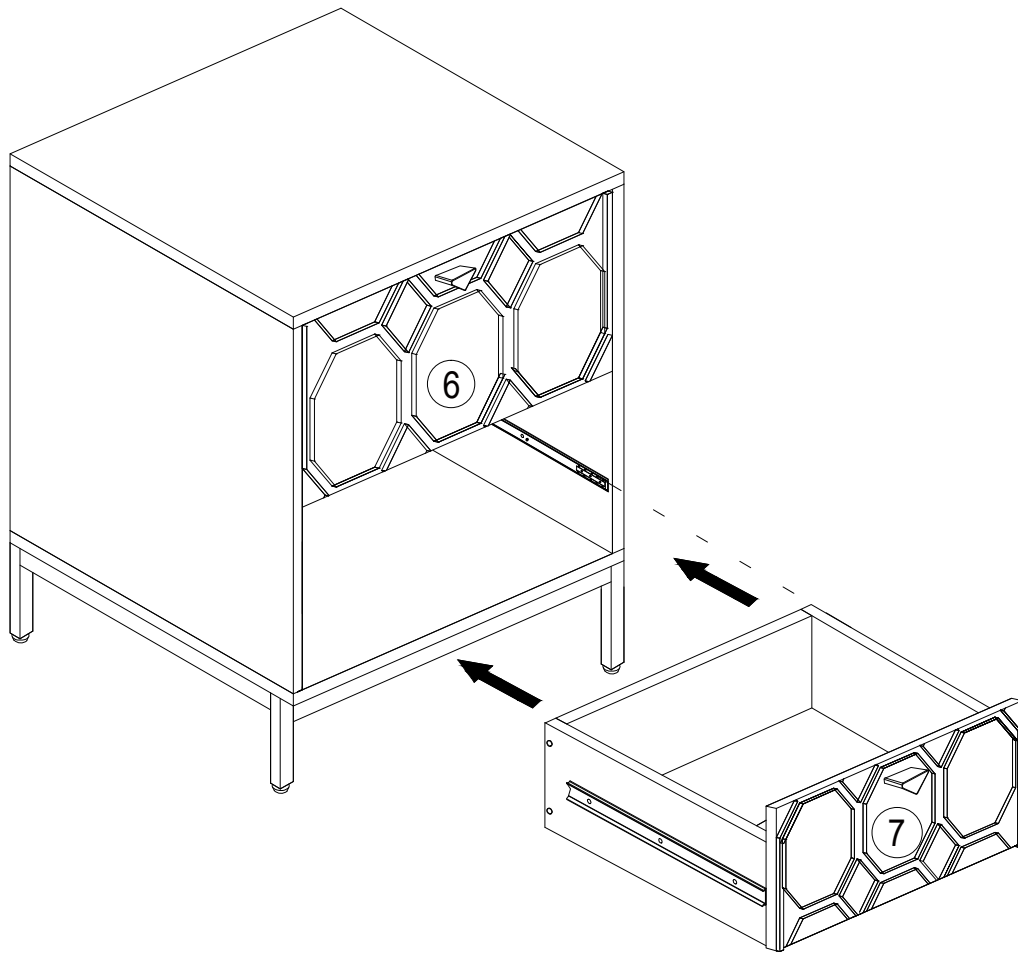

Reminder: After the installation of the drawer is completed, pull it several times to ensure smooth operation. If you need to exit the drawer, please refer to the following steps.

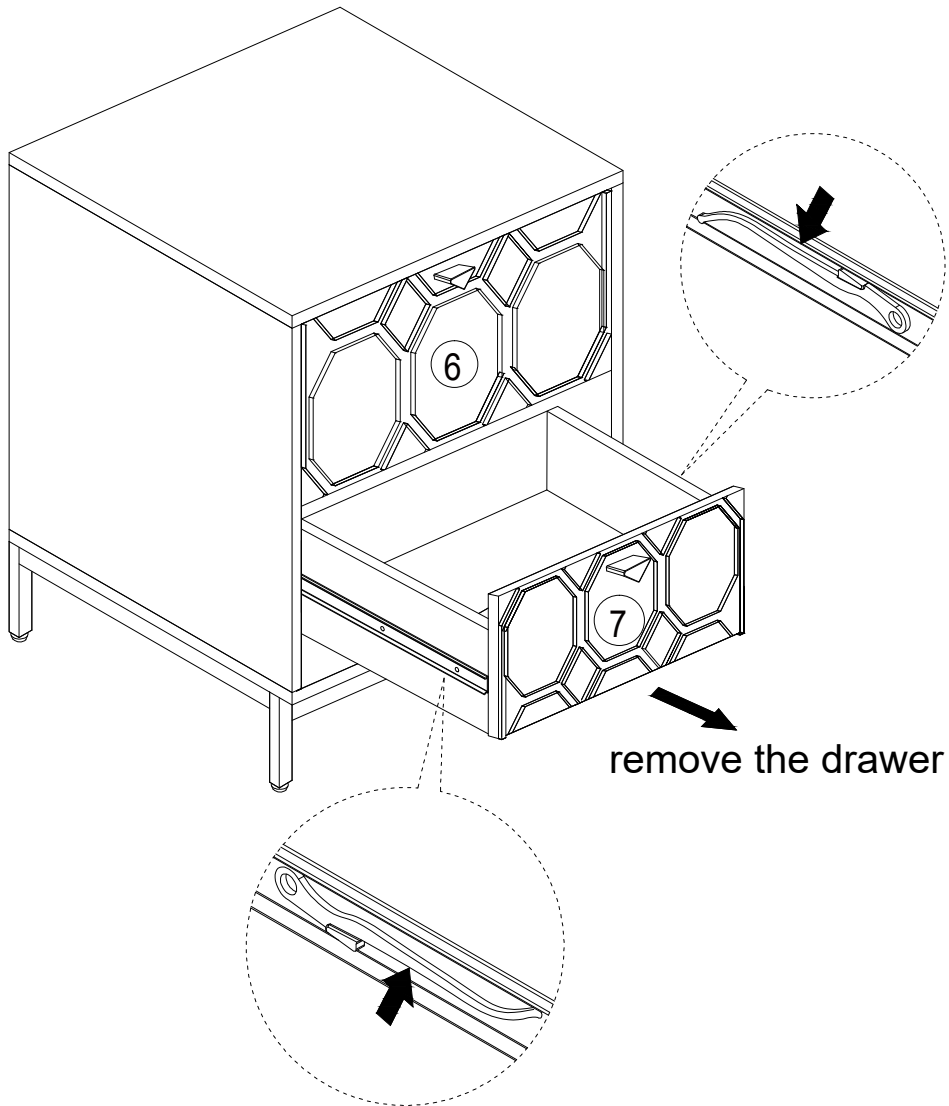

STEP 8



To remove the drawer: Lift the left buckle and press down the right buckle simultaneously, then pull outward to disengage the drawer from the rails.

ASSEMBLY INSTRUCTIONS

STEP 9

J:		1PC
K:		1PC
L:		1PC

Drill a 1/8" hole into the wall at the marked position.

Insert Plastic anchor (Part J) into the hole.

Place Washer (Part L) over Mounting screw (Part K), then drive the screw through the Safety wall strap (Part I) and into the anchor. Tighten until the strap is firmly attached to the wall.

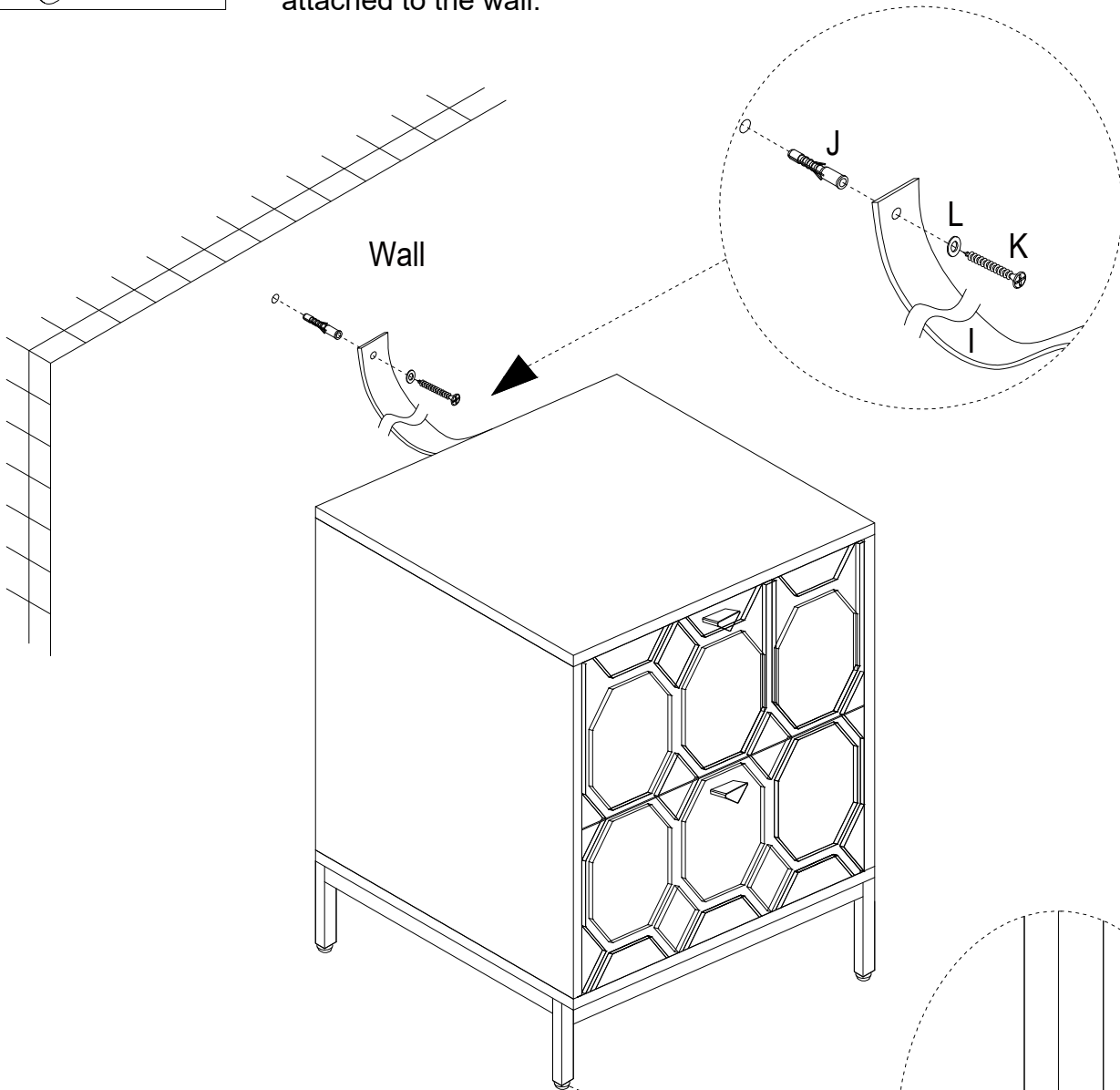

After installation, adjust the adjustable foot to keep the cabinet balanced and align the door.

