

Installation & Assembly

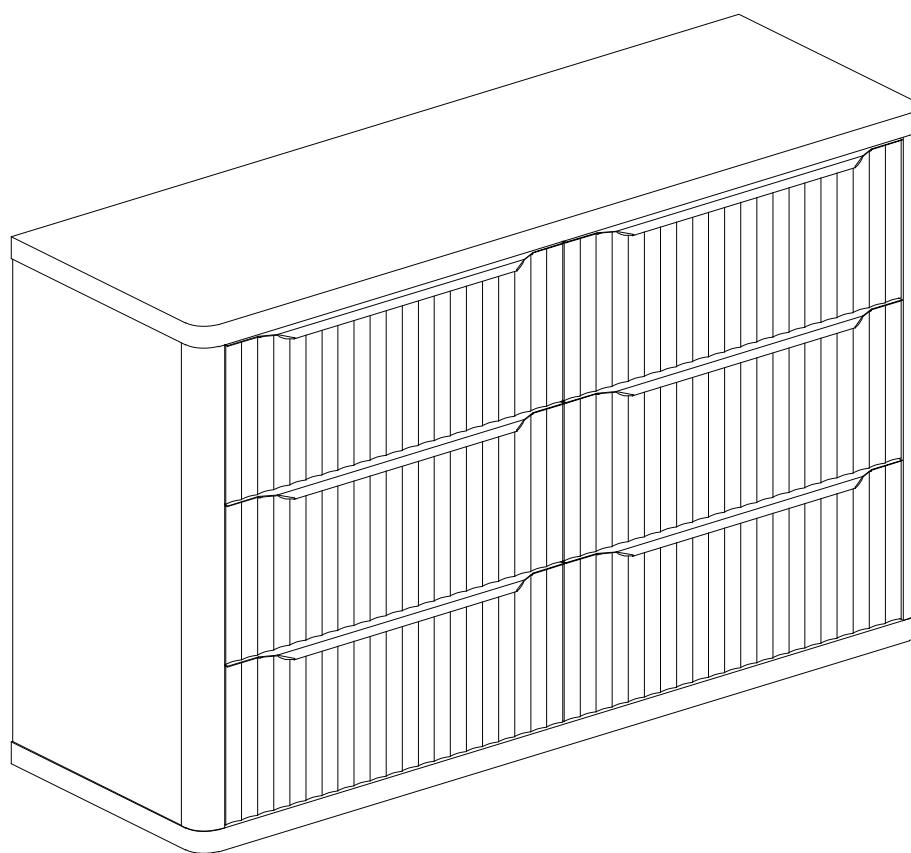

Made In China

Assembly Instructions

Before beginning the assembly process, please read and save these instructions for reference. Following these guidelines will ensure a smooth and successful assembly of your product.

1. Part Identification:

Carefully separate and identify all the parts included in your package. Confirm that you have all the components listed in the instruction manual. This step will help you avoid any missing or misplaced parts during assembly.

2. Work Surface:

To prevent any scratches or damage to the product, assemble it on a soft mat or a similar protective surface. This will provide a cushioned area for the components and protect the surfaces from unwanted marks.

3. Step-by-Step Assembly:

Follow the assembly instructions provided, proceeding one step at a time. Take care to understand each step properly before proceeding to the next one. This sequential approach ensures that the assembly is done correctly and minimizes the chance of errors.

4. Proper Screw Seating:

When attaching screws and nuts, it is essential not to fully tighten them until all screws are correctly seated. By partially tightening each screw and nut initially, you can ensure that they are aligned properly and fit securely before final tightening.







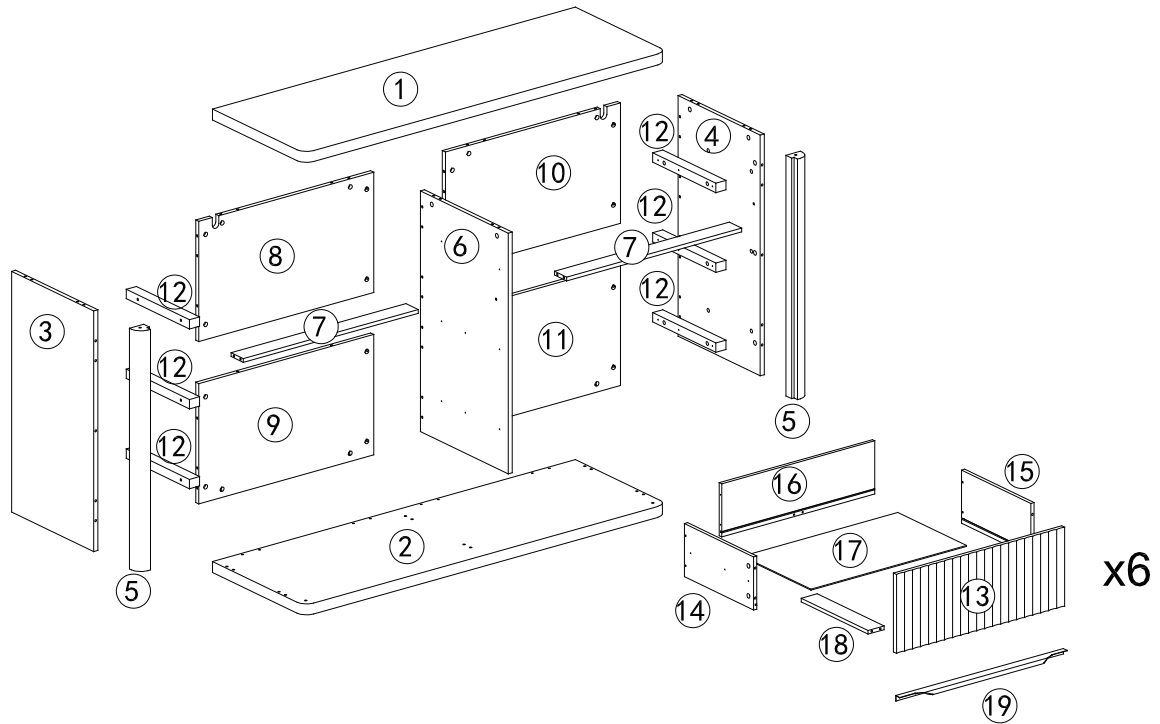







5. Avoid Over-Tightening:

While each screw and nut should be tightened correctly, it is crucial not to over-tighten them. Over-tightening can cause damage to the product or compromise its structural integrity. Use the appropriate amount of force to secure the components without excessive tightening.

Parts List



Hardware List

Ax78  M6x35mm	Bx78  ø15x10mm	Cx48  ø8x30mm	Dx6  M7x68mm	Ex1  M4	Fx12  M6x35	Gx36  ø4x35	Hx18  ø3x12
Ix72  ø4x12	Jx2  ø4x14	Kx2  ø4x35	Lx6  M8x(ø30)x20	Mx2 	Nx2 	Ox12  ø4x12	

Code	Description	Quantity
A	M6x35mm Cam bolt	78+4
B	ø15x10mm Cam lock	78+4
C	ø8x30mm Wood dowel	48+2
D	M7x68 Broken tail screw	6+1
E	Hexagon socket wrench	1
F	M6x35 hexagonal screw	12+1
G	ø4x35 self-tapping screw	36+2
H	ø3x12 self-tapping screw	18+2
I	ø4x12 self-tapping screw	72+4
J	ø4x14 self-tapping screw	2+1

Code	Description	Quantity
K	ø4x35 self-tapping screw	2
L	M8x(ø30)x20 Adjustable foot	6+1
M	Plastic expansion screw	2
N	Lock wall accessories	2
O	Drawer slider	12

Step 1

Press the plastic part in the indicated direction to separate drawer runner O-1 and O-2 before assembling.

Attention:
Please grip the O-1 part while sliding
the O-2 part.

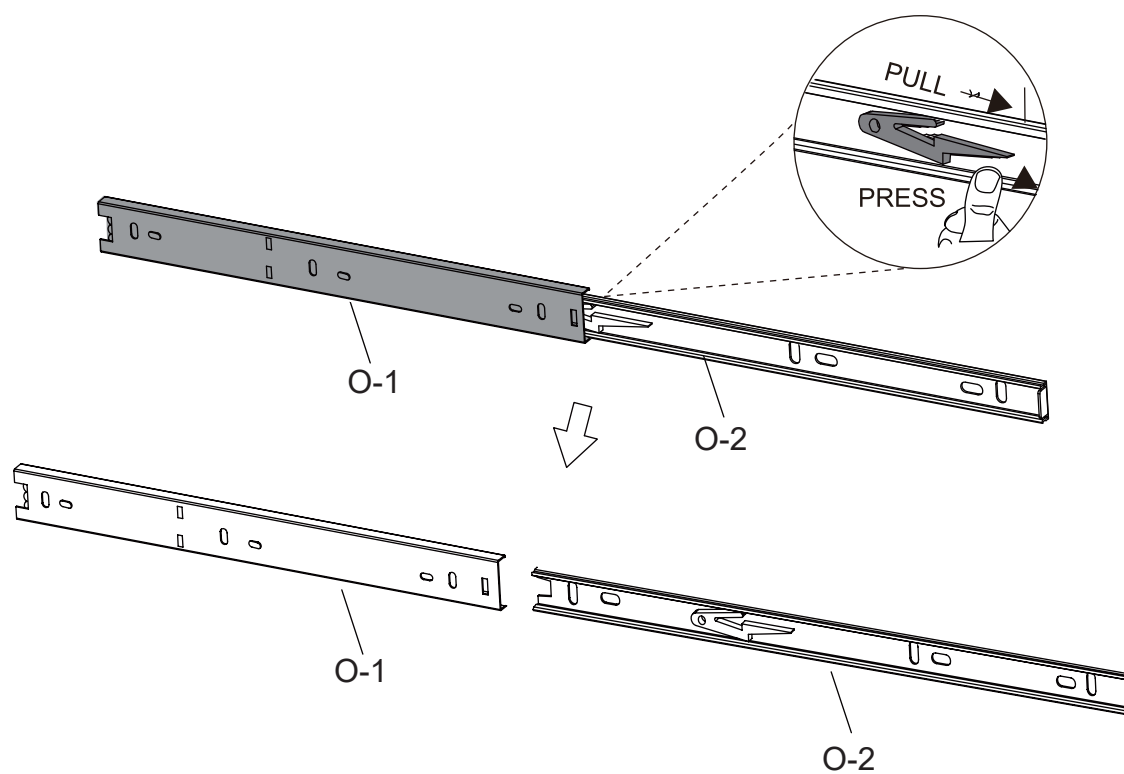

Step 2

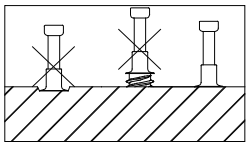
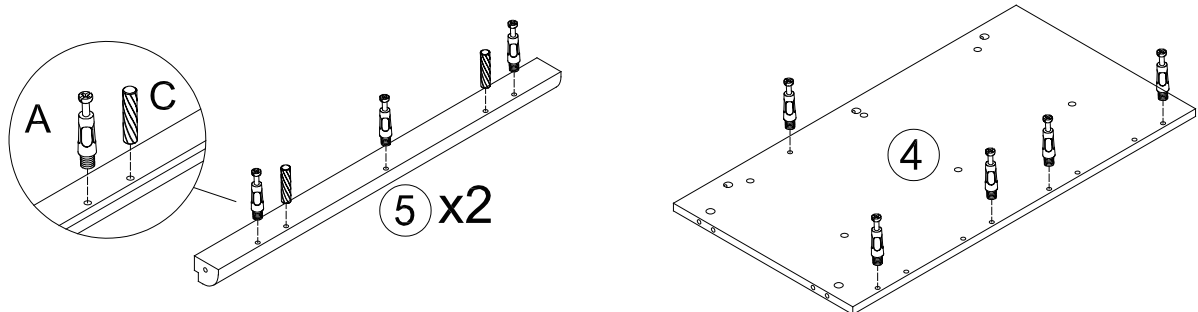

A  x 17

C  x 4

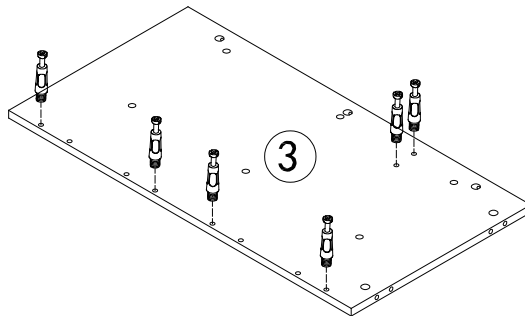

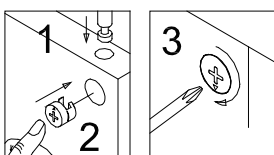
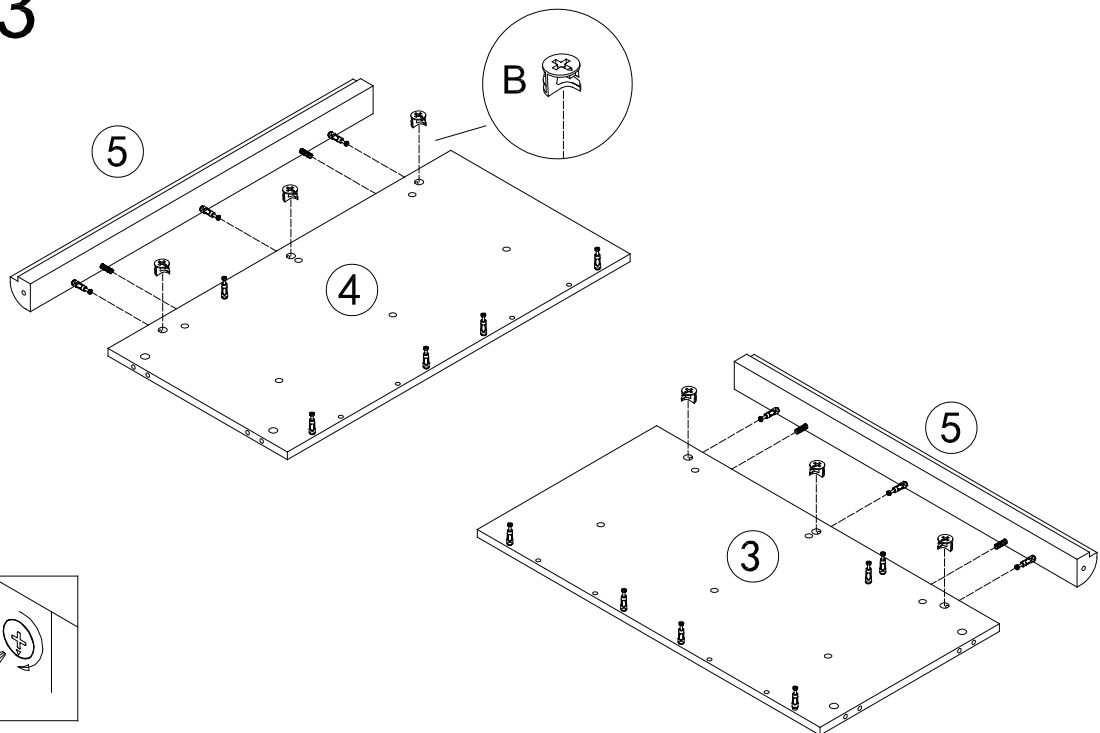

Step 3

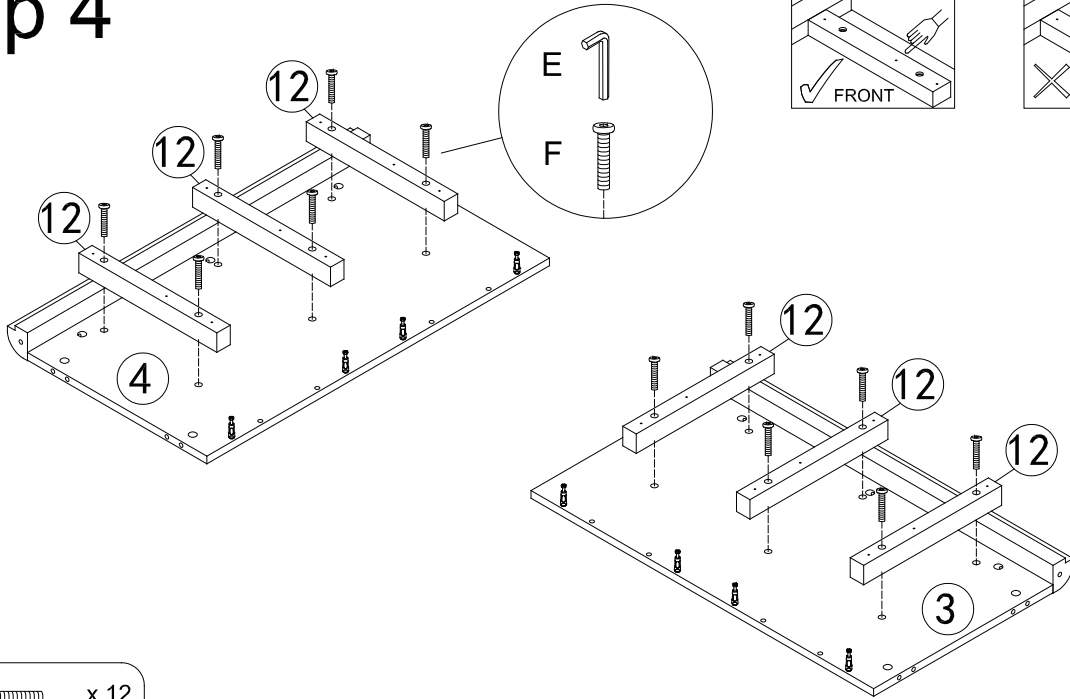

B  x 6

Step 4





F  x 12

E  x 1

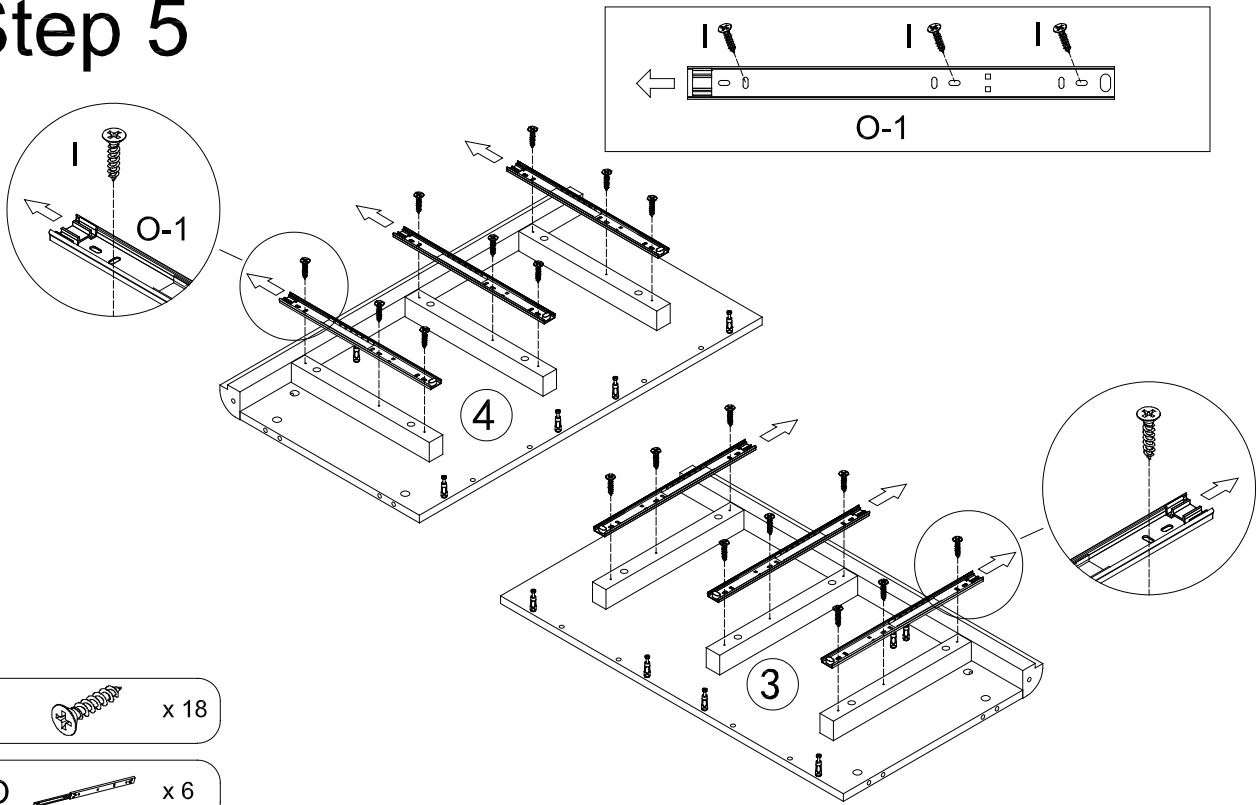
Step 5





I  x 18

O  x 6

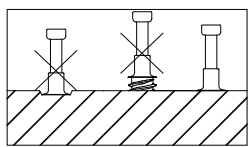
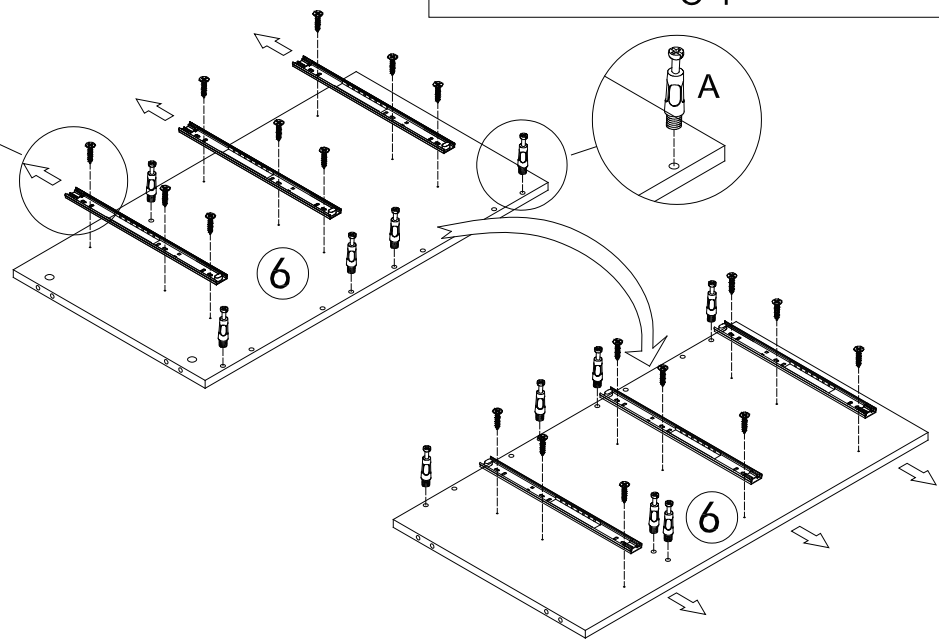
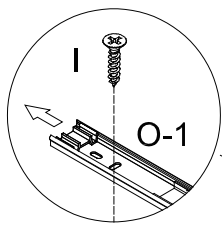
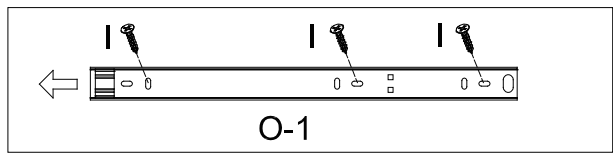
Step 6



- A  x 11
- I  x 18
- O  x 6

Step 7

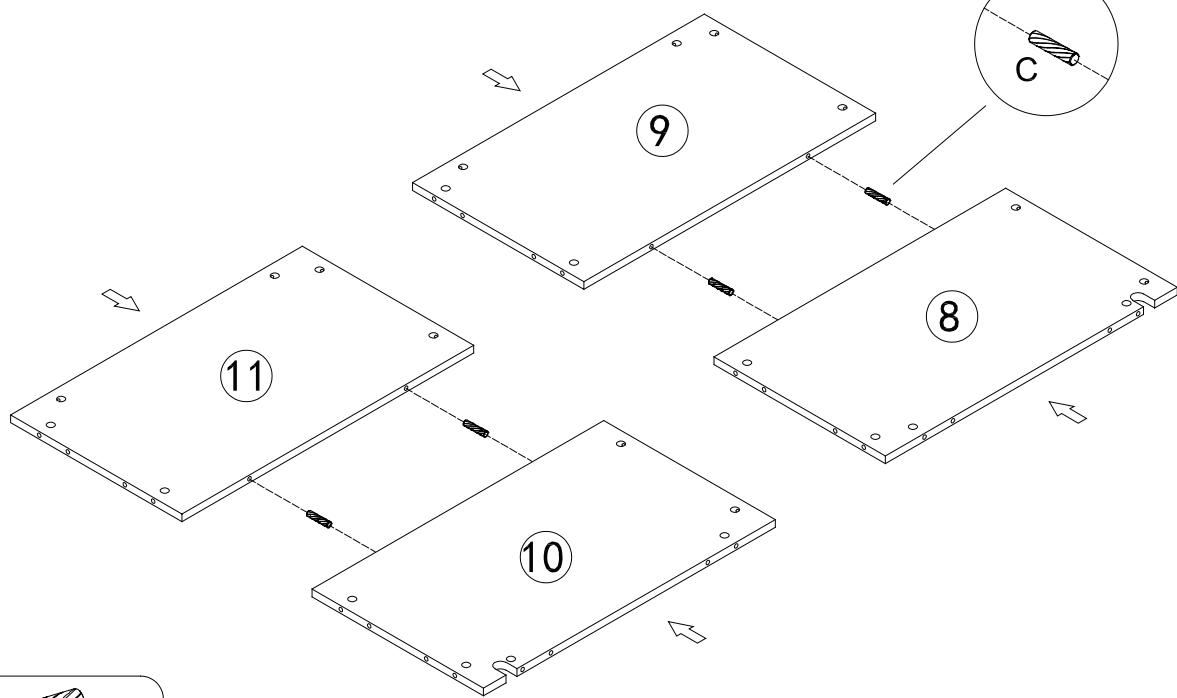
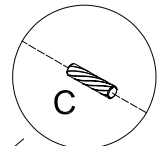

- C  x 4

Step 8

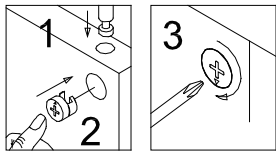
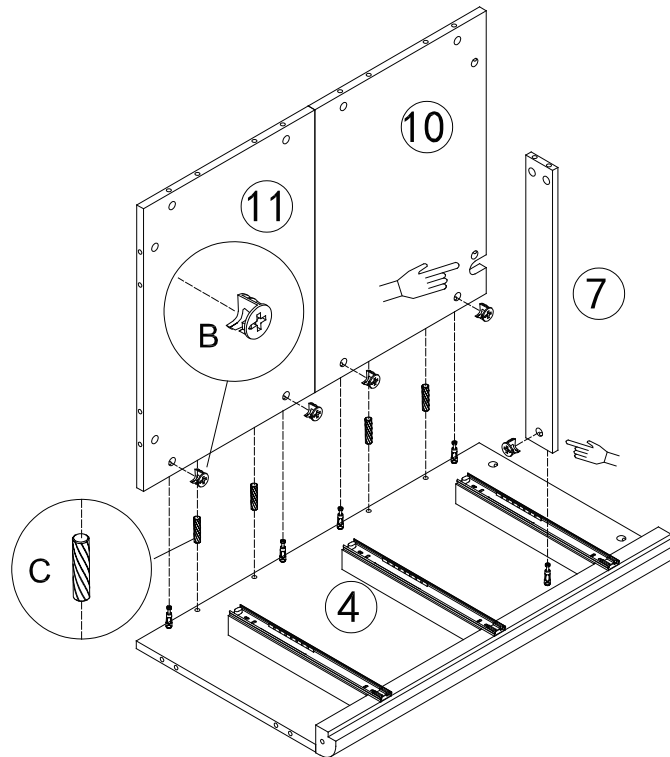

B  x 5

C  x 4

Step 9

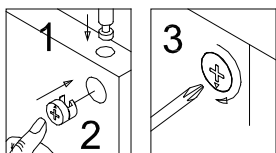
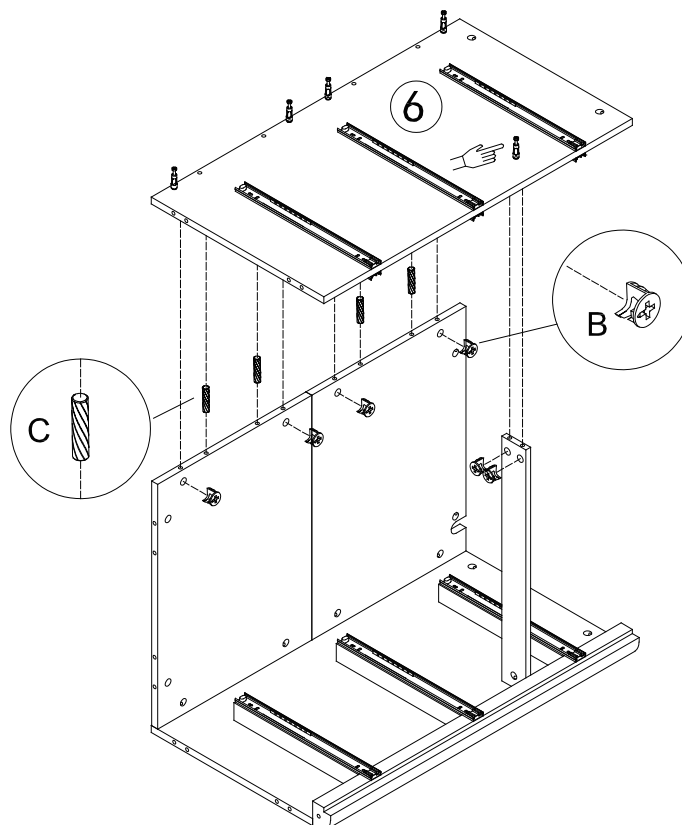

B  x 6

C  x 4

Step 10

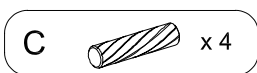
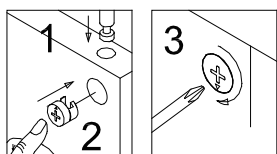
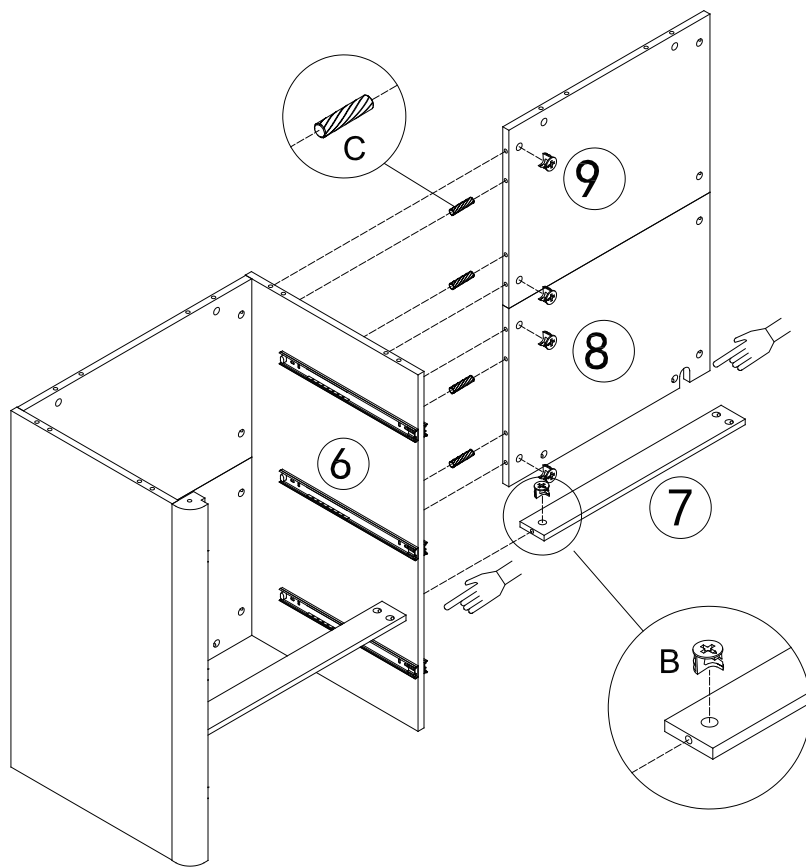

Step 11

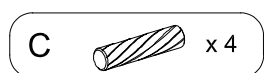
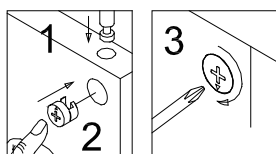
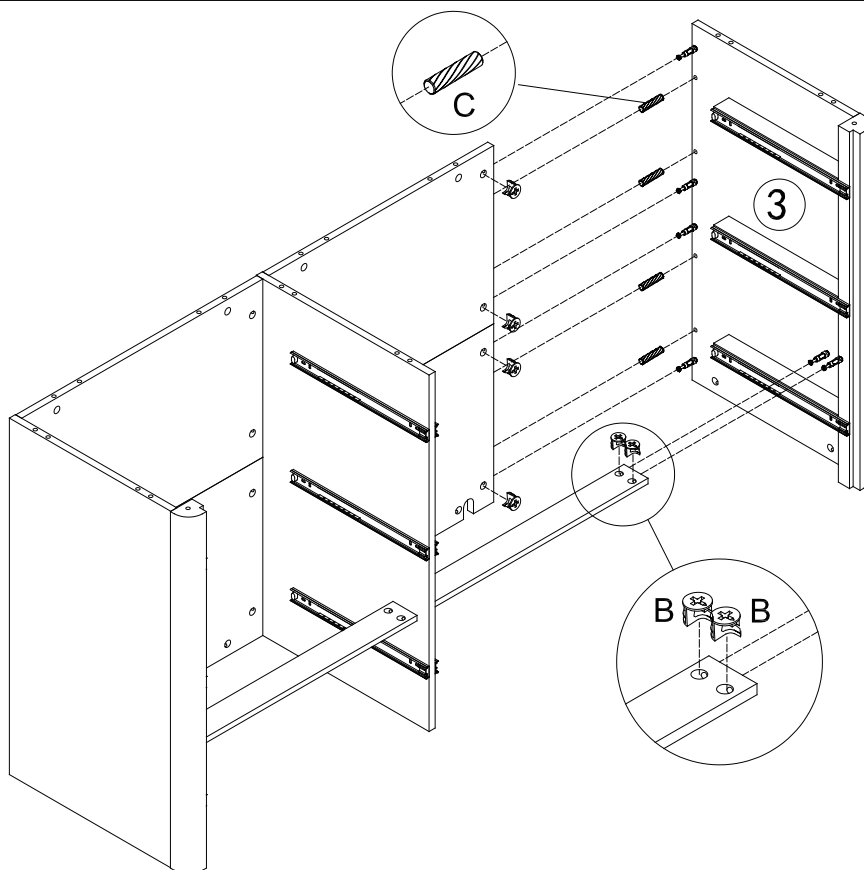

Step 12

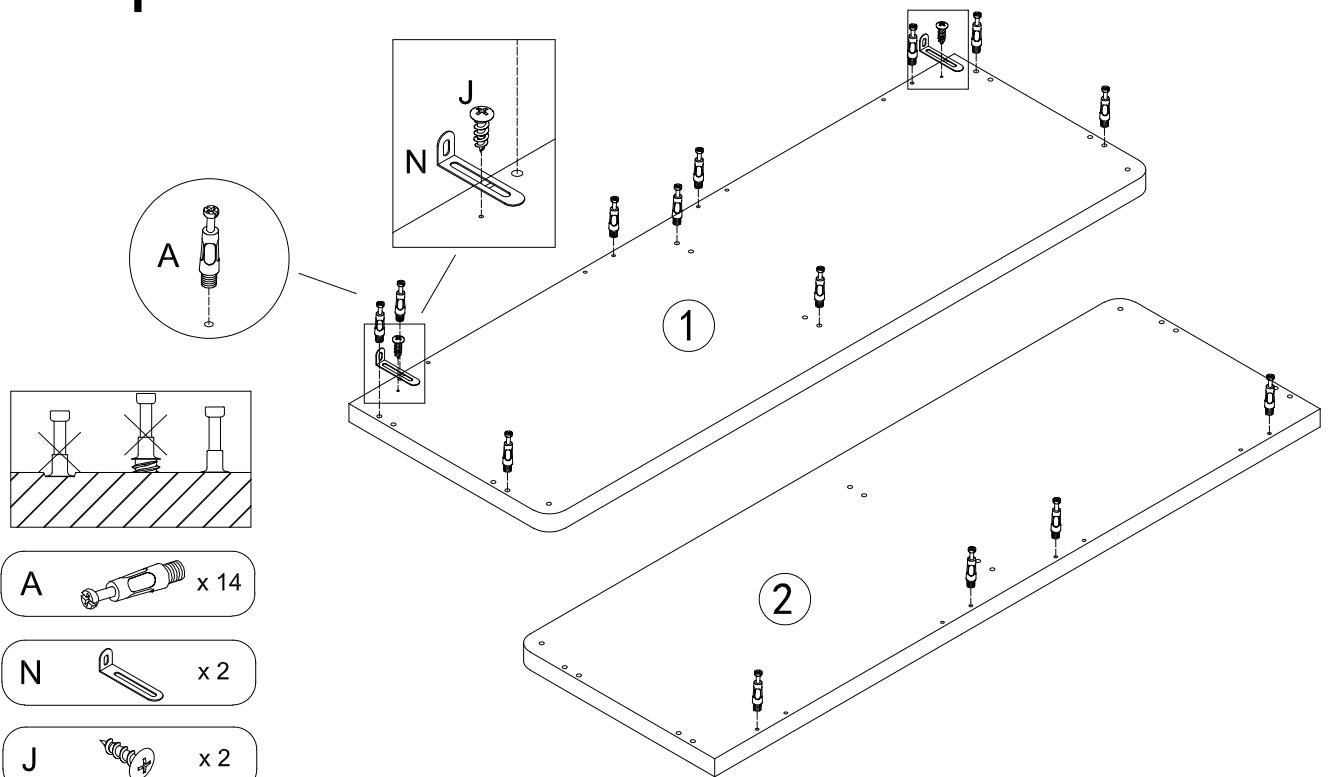

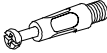
A  x 14

N  x 2

J  x 2

Step 13

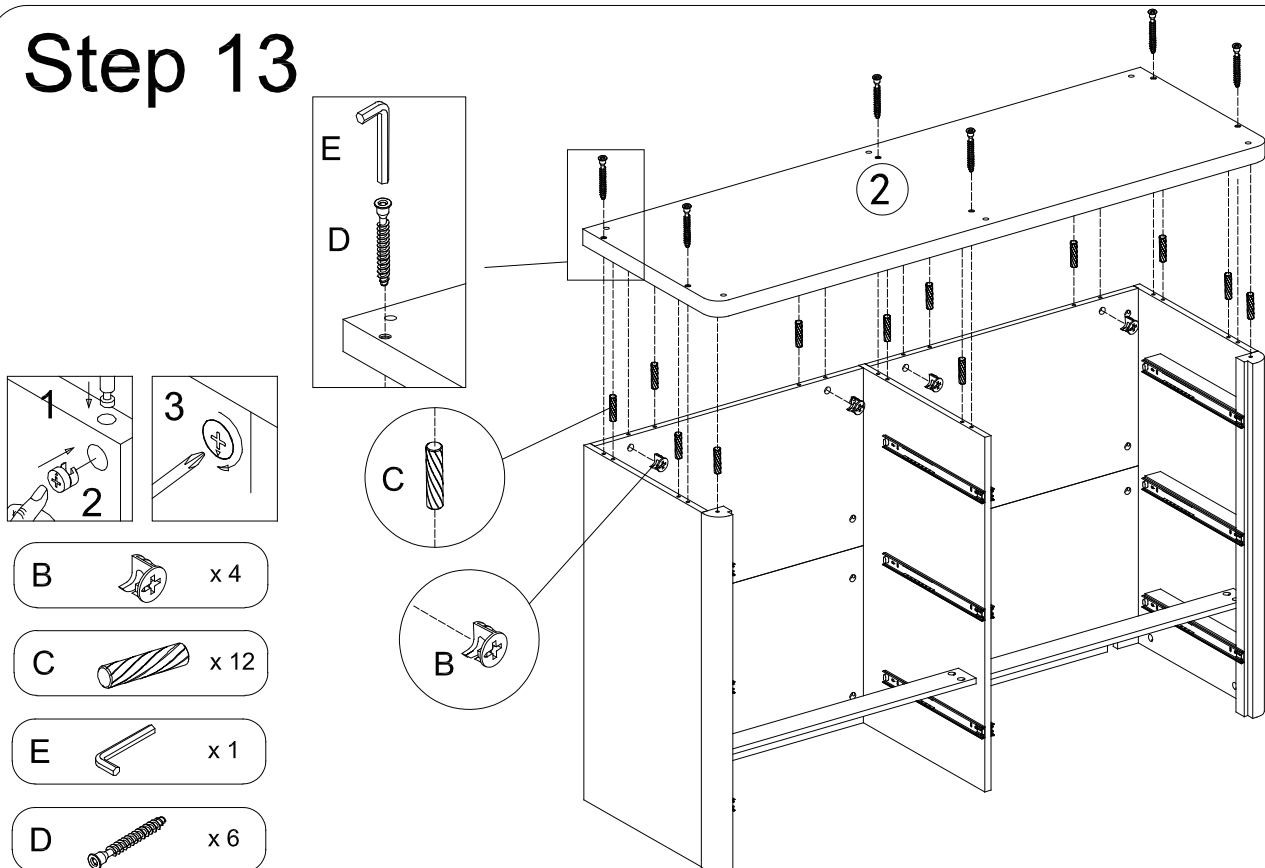

B  x 4

C  x 12

E  x 1

D  x 6

Step 14

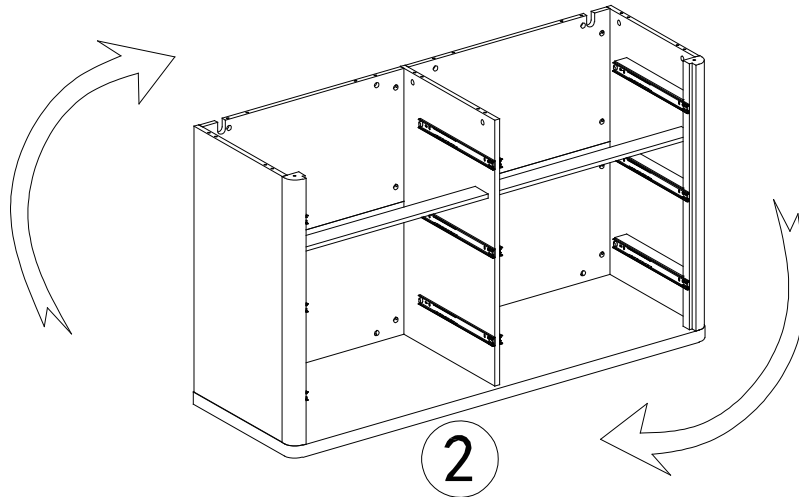

Step 15

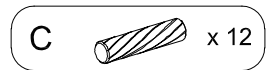
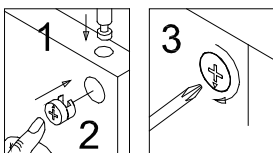
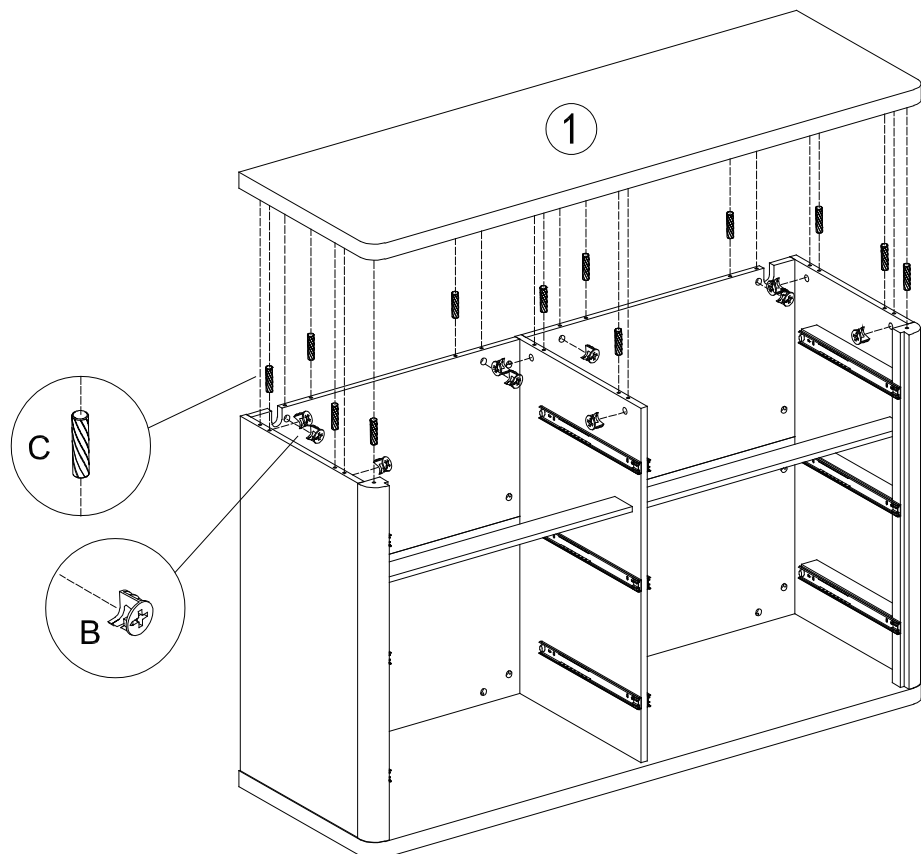

Step 16

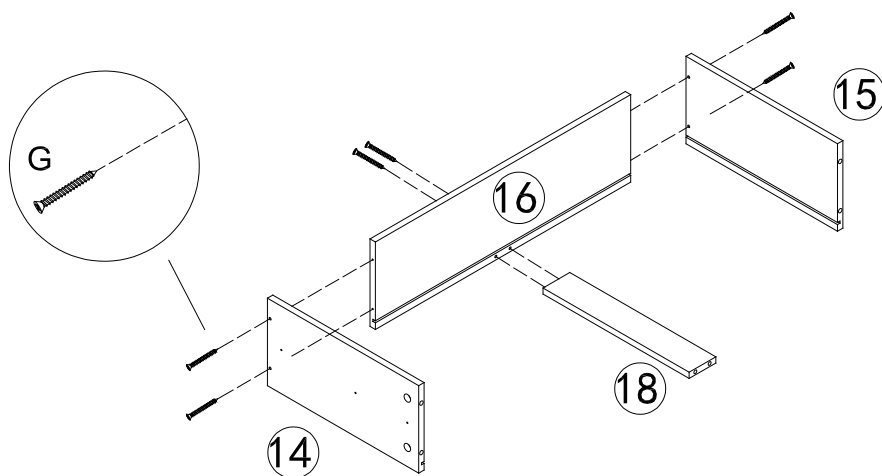

X6

G  x 36

Step 17

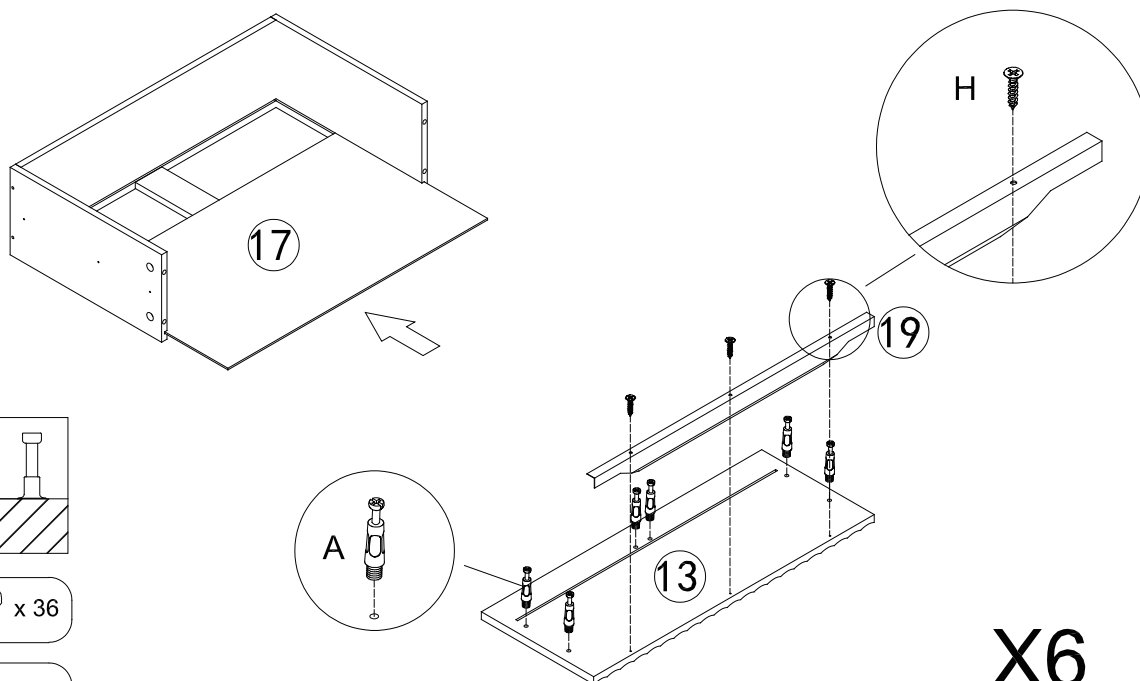

X6

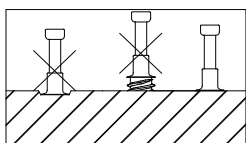

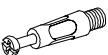
A  x 36

H  x 18

Step 18

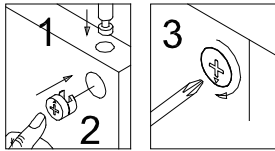
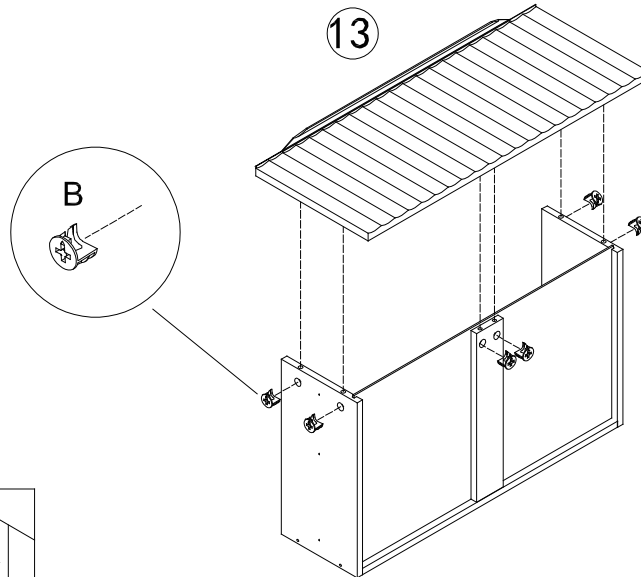



B  x 36

X6

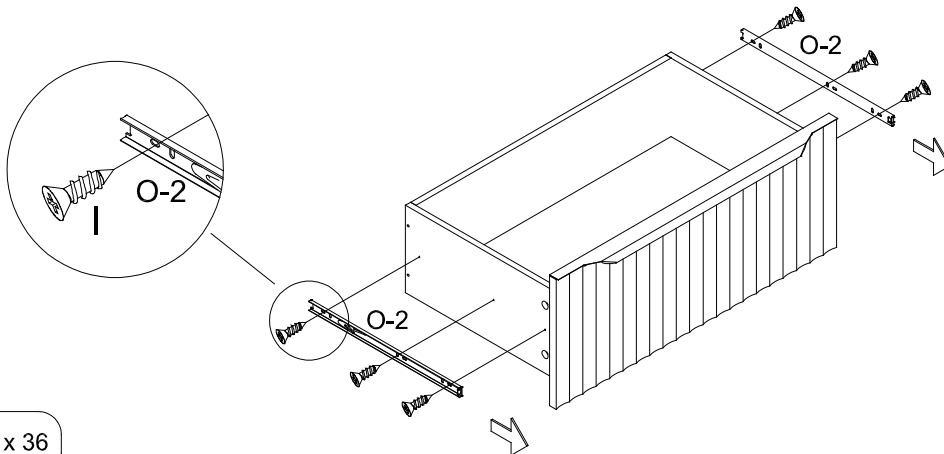
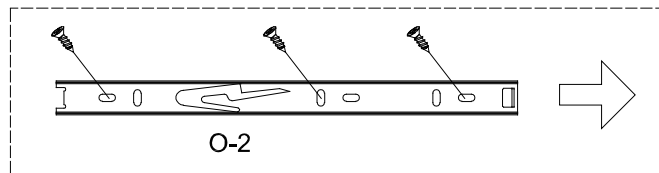
Step 19



I  x 36

O  x 12

X6

Step 20

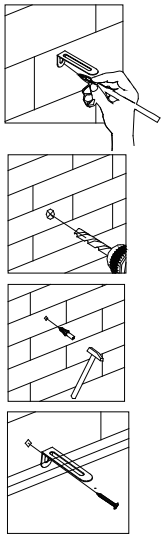

K  x 2

M  x 2

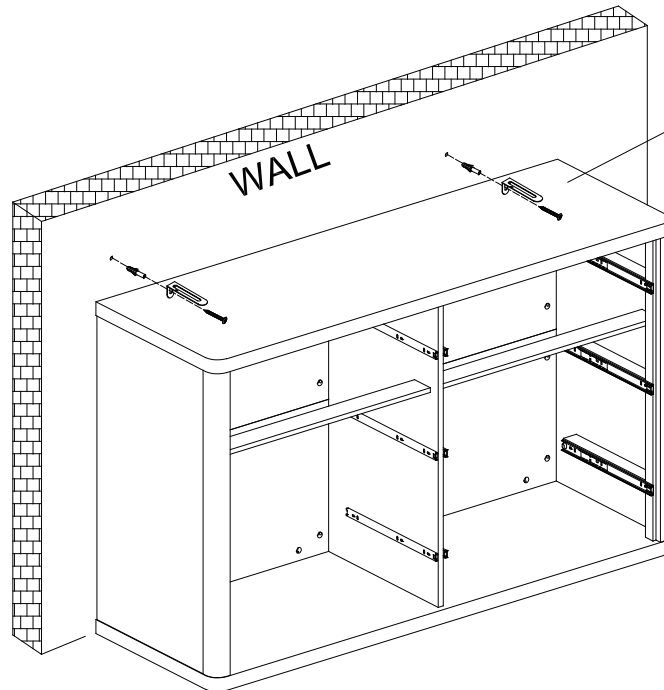

Step 21

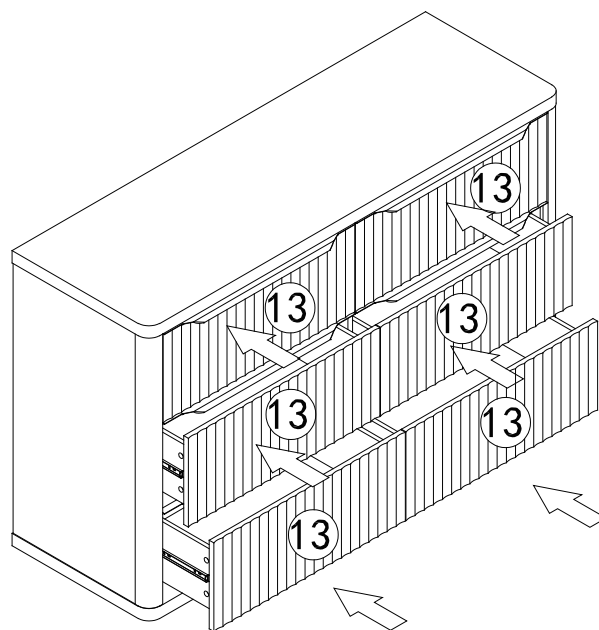

Step 22

