

# ASSEMBLY INSTRUCTIONS

Thank you for purchasing our product.

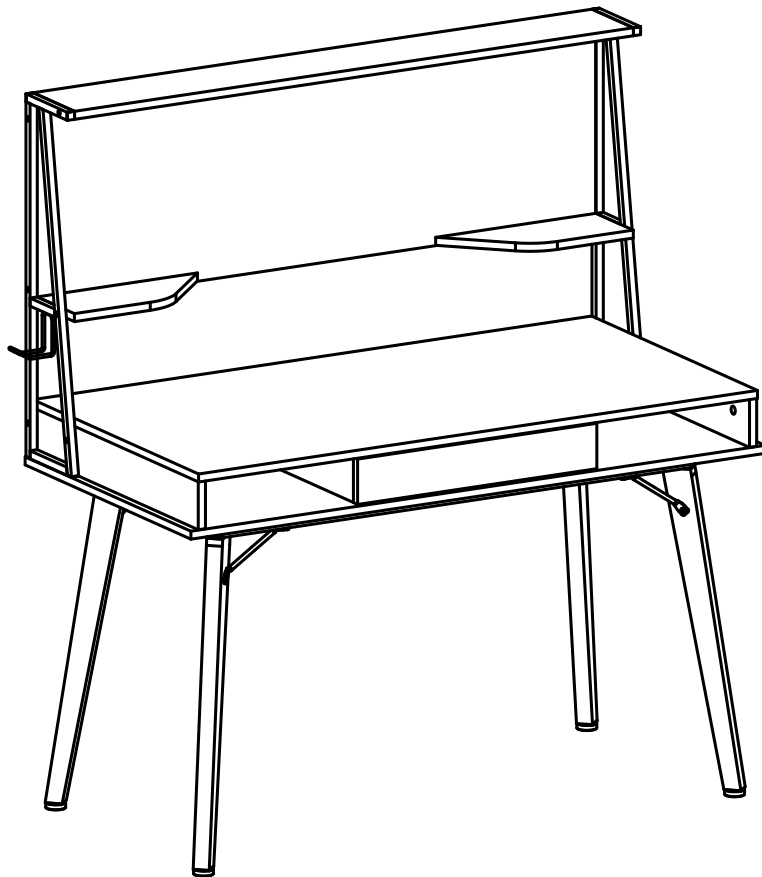



- Please read carefully the assembly instructions before the installation.



- Do not discard this manual or any of the packaging material until the unit has been completely assembled.







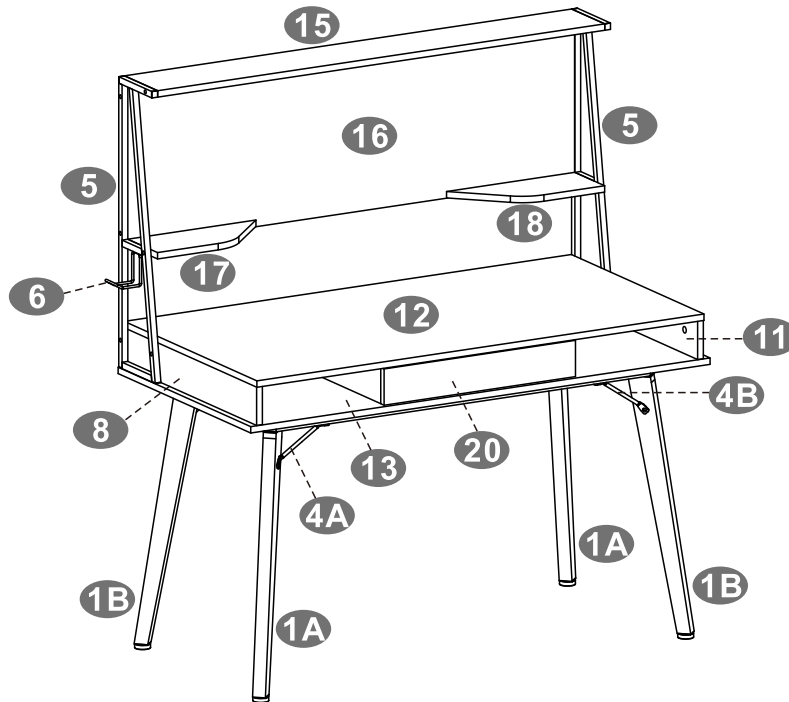

- Might require two people.

■ PARTS LIST

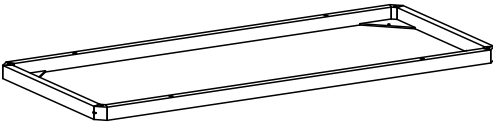
Parts Layout  
(for reference):

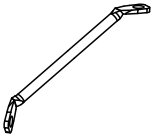
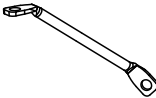
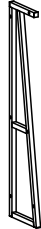
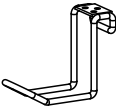

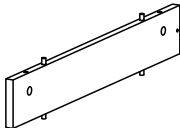
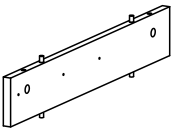
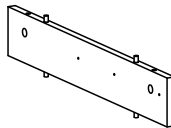
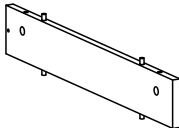
<p>Front-Left and Back-Right <b>1A</b></p>  <p>X2</p>	<p>Back-Left and Front-Right <b>1B</b></p>  <p>X2</p>	<p>Main structure <b>2</b></p>  <p>X1</p>	<p>Studs <b>3</b></p>  <p>X4</p>	
<p>Leg Support: Front-Left and Back-Right <b>4A</b></p>  <p>X2</p>	<p>Leg Support: Front-Right and Back-Left <b>4B</b></p>  <p>X2</p>	<p>Side structures <b>5</b></p>  <p>X2</p>	<p>Accessory hanger <b>6</b></p>  <p>X1</p>	<p>Drawer connectors <b>7</b></p>  <p>X2</p>
<p>Left external side panel <b>8</b></p>  <p>X1</p>	<p>Left internal side panel <b>9</b></p>  <p>X1</p>	<p>Right internal side panel <b>10</b></p>  <p>X1</p>	<p>Right external side panel <b>11</b></p>  <p>X1</p>	

Main panel

12

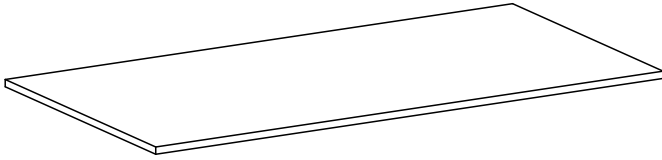

X1

Bottom panel

13

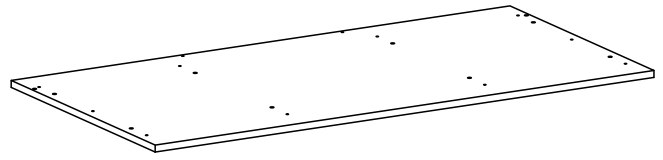

X1

Lower back panel

14

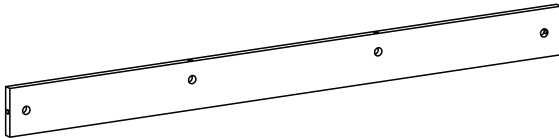

X1

Top shelf panel

15

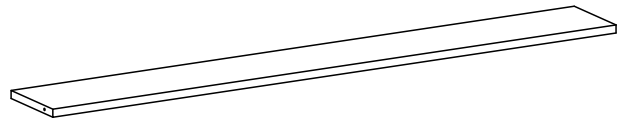

X1

Upper back panel

16

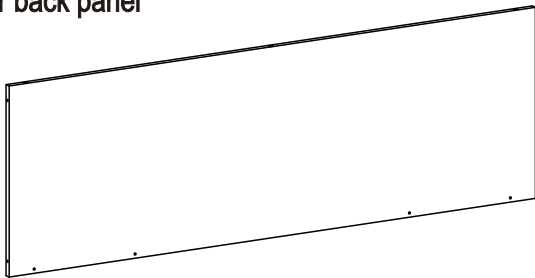

X1

Left middle shelf

17



X1

Right middle shelf

18



X1

Drawer sliders

19

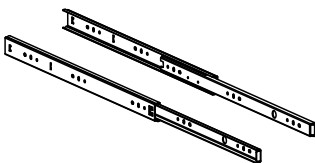

X1

Note: Both are the same

Drawer front panel

20



X1

Drawer left panel

21

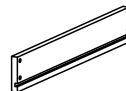

X1

Drawer Right panel

22



X1

Drawer bottom panel

23



X1









Drawer back panel



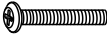

24

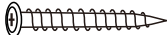

X1

## SCREWS LIST

PART	QTY.	ITEM	
<b>A</b>	12	6X40 MM	
<b>B</b>	2	6X12 MM	
<b>C</b>	6	6X25 MM	
<b>D</b>	8	6X40 MM	
<b>E</b>	2	4X10 MM	
<b>F</b>	12	5X40 MM	
<b>G</b>	8	3X12 MM	
<b>H</b>	6	3X15 MM	
<b>I</b>	4	4X35 MM	

PART	QTY.	ITEM	
<b>J</b>	12	5X45 MM	
<b>K</b>	3	6X25 MM	
<b>L</b>	12	6X15 MM	
	1	M 4	
	1		

☛ This unit uses cam bolts and locks. The following explains how to use them. This is not an assembly step; it is a guide for when you are actually doing the assembly using this kind of hardware.

Cam Lock



Cam Bolt

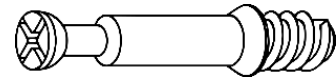

1. Screw the bolt into the corresponding hole on panel "A".

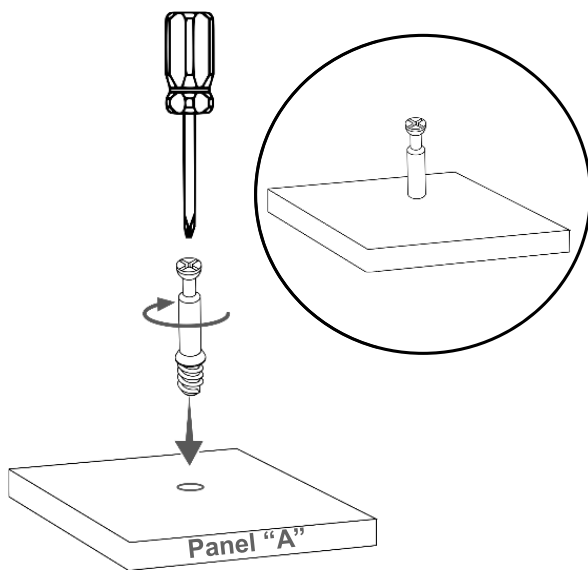

2. Join panel "B" to panel "A". If panel "B" comes with the cam lock pre-installed, make sure it is aligned to receive the bolt's head (refer to point 3). There might be a very small gap between the panels which is normal.

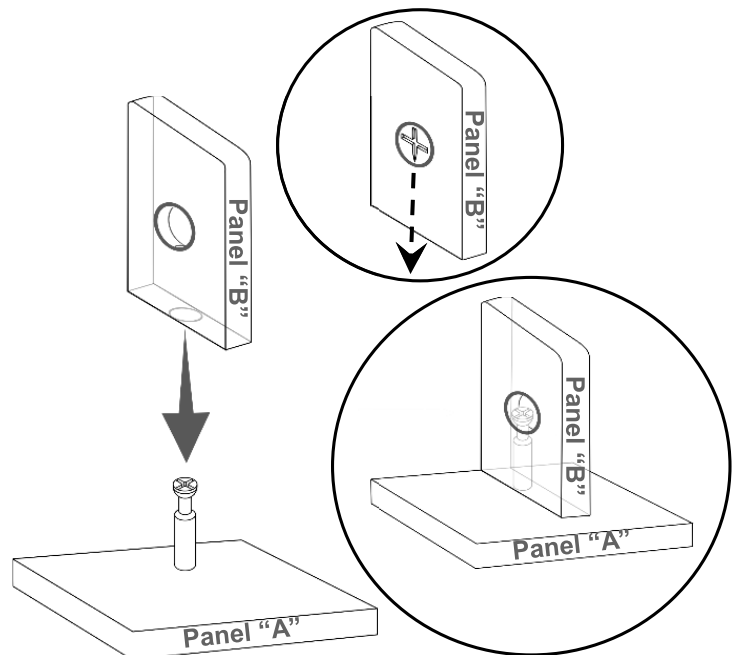

3. Insert the cam lock on panel "B" making sure it goes aligned to receive the bolt's head.

**Alignment:** The cross points towards the panel "A" with the bolt.

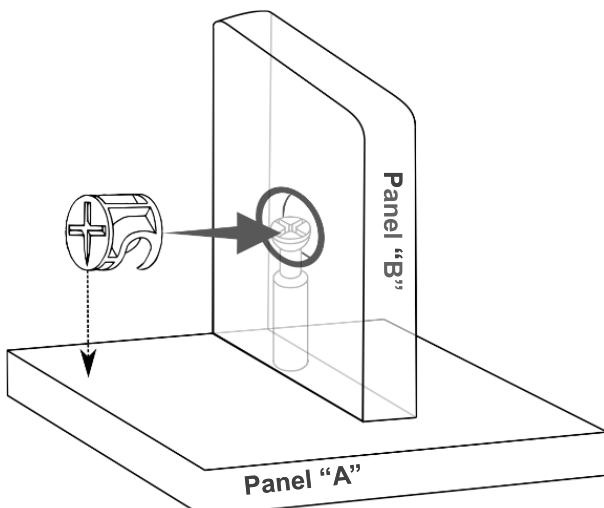

4. Turn the cam lock clockwise. This will lock the parts together and will close any gaps.

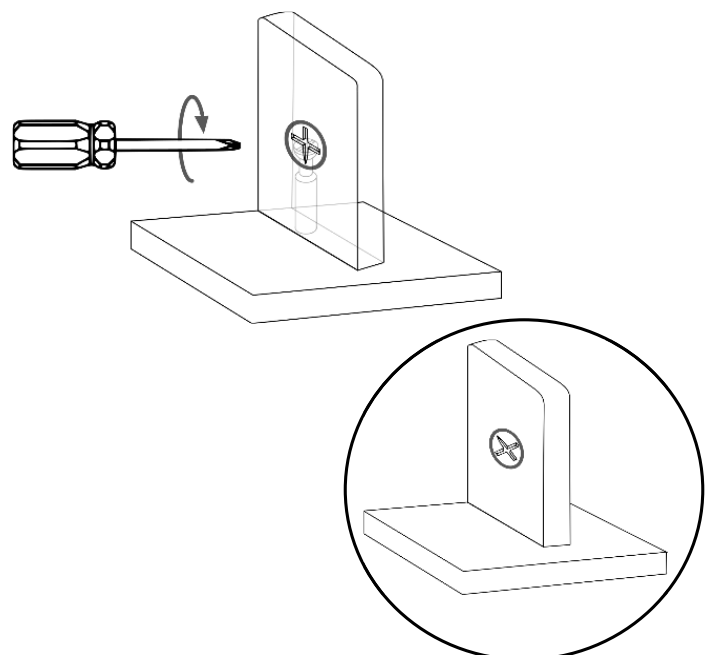

**BEFORE YOU START THE ASSEMBLY, PLEASE READ THE FOLLOWING TIPS AND WARNINGS.**

**1** Do a quick inventory to make sure the package contains all the parts and hardware listed in the assembly instructions.



**7** To avoid misalignments, always leave the screws loose and tighten them until all pieces are positioned correctly.

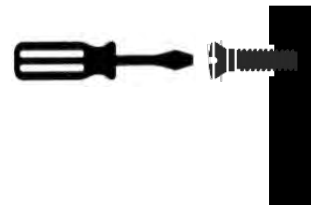

**2** Missing, damaged and defective parts can be replaced at no cost to you. Please refer to the last pages on this manual.



**8** Do not overtighten or force the screws as they might break, strip, damage the threads of the holes or get stuck inside the part.

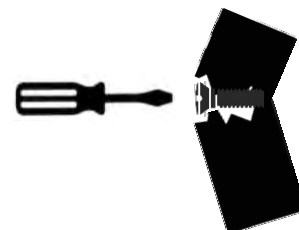

**3** The replacement parts service is limited to the 48 contiguous United States. If you reside in Alaska, Hawaii, Puerto Rico, U.S. Territories or other countries, please contact the supplier from where the unit was purchased.



**9** Sometimes the laminate might cover partially or entirely the hole on a panel. If there is no visible hole for the screw, pass and press the tip of your finger over the area where the hole should be located to feel the indentation, and once found, carefully pierce the laminate to reveal the hole underneath.



**4** If during assembly you find an issue or need clarification, please contact our Customer Service for assistance.



**10** If the hole seems too small for the screw, first make sure you are using the correct size of screw and that it's been installed in the correct hole. If the hole still appears to be too small, carefully pierce the laminate to reveal the hole's actual size.

**6** Make sure you understand which hardware will be used on each step. Using the wrong size of screw, bolt or pin might strip the threads or cause damage to the part in which it is being used.

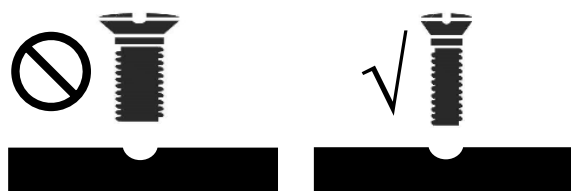
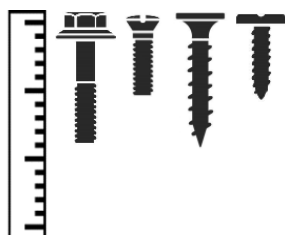

## ASSEMBLY STEPS:

- 1** With the help of another person, assemble the legs (1A) and (1B) to the main structure (2) with screws (D) in the exact positions shown, and making sure the triangle plates from 2 face down for proper assembly in the next step.

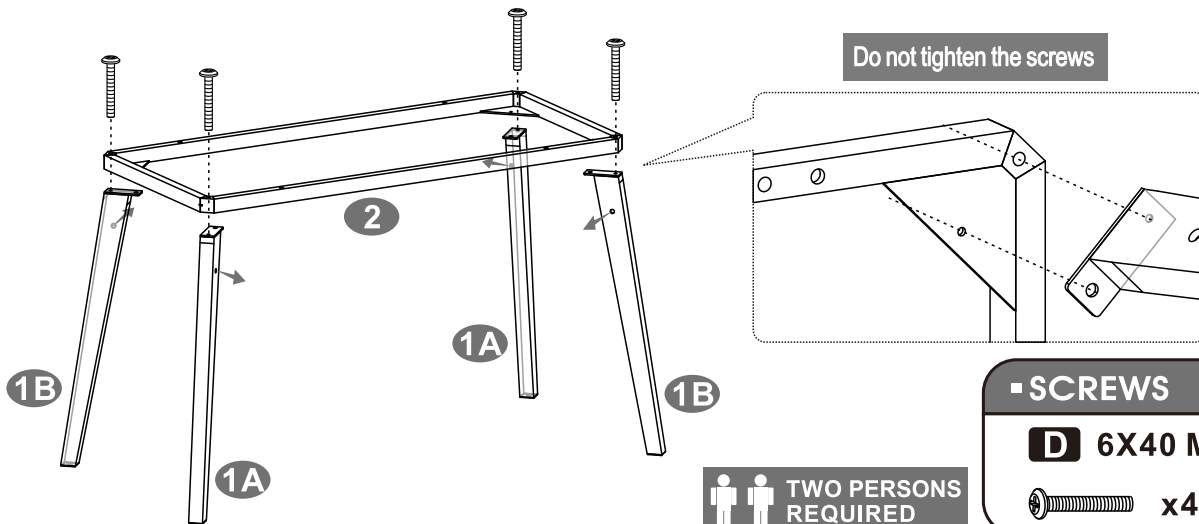

- 2** Secure the legs (1A) and (1B) to the frame (2) with screws (L) from underneath.

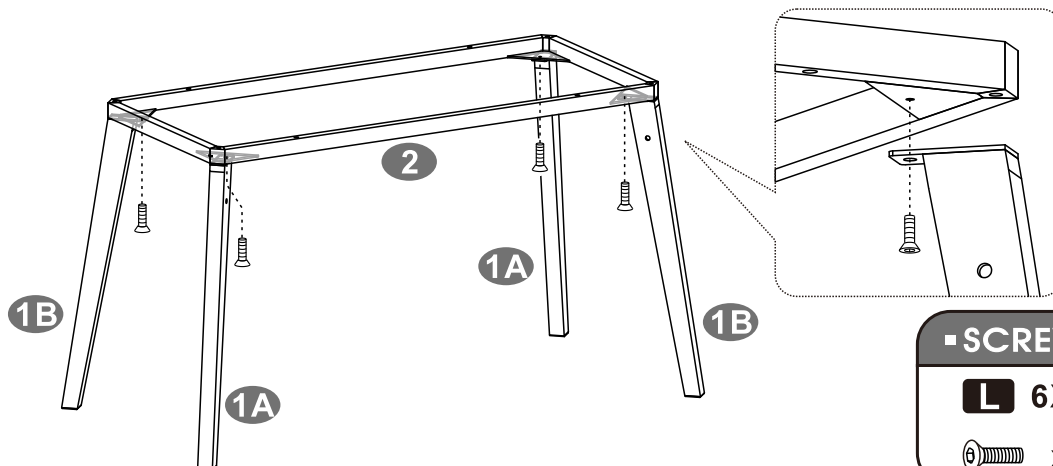

- 3** Use screws (L) to assemble:

- \*The leg supports (4A) to the legs (1A) and the frame (2).
- \*The leg supports (4B) to the legs (1B) and the frame (2).

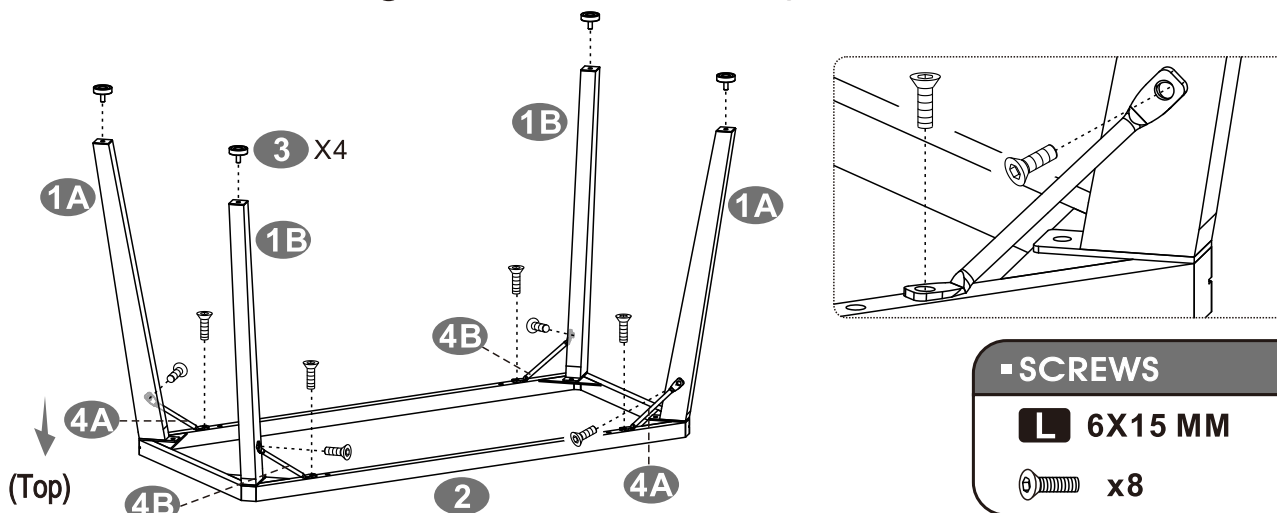

4

Assemble the external side panels ⑧ and ⑪ to the lower back panel ⑭ using bolts ① as shown and as explained in page 4.

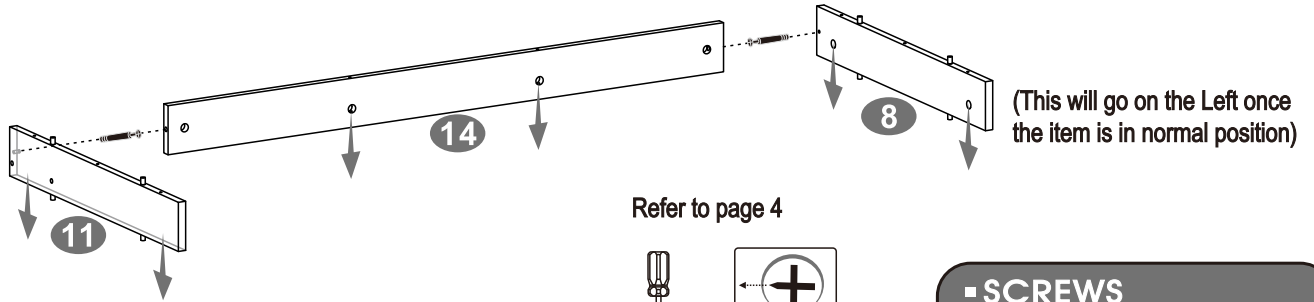

Pay attention to the orientation of the panels: They are shown here upside-down.

(Top)

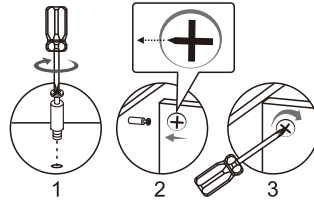

■ SCREWS

**A** 6X40 MM

X2



5

With the main panel ⑫ placed upside-down and its front edge towards you, assemble the external side panels ⑧, ⑪, ⑭ and the internal side panels ⑨ and ⑩ using bolts ① as shown and as explained in page 4.

Pay attention to the orientation of the panels 9 and 10: The holes for sliders (step 6) face towards the inside.

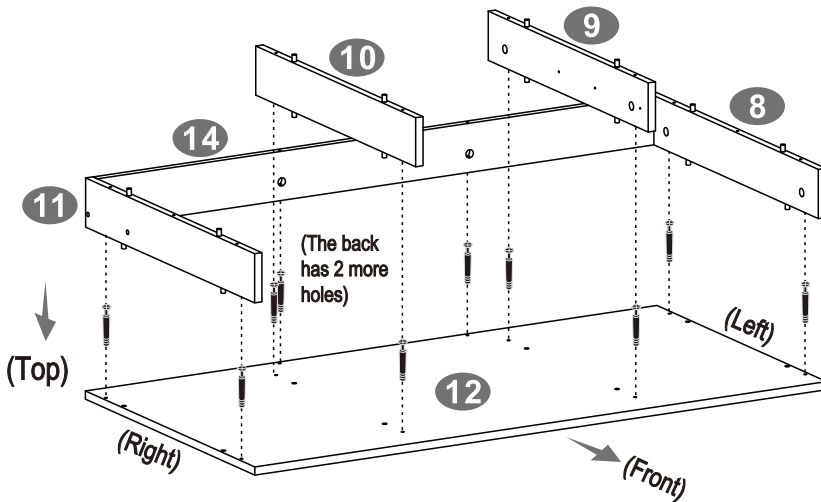

Refer to page 4

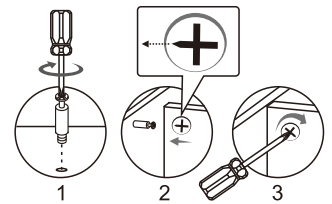

■ SCREWS

**A** 6X40 MM

X10



6

Open the sliders ⑲ slowly until you see the first hole on the back side of the slider thru the big opening, and using screws ② assemble the sliders to the internal panels ⑨ and ⑩ on the front as shown.

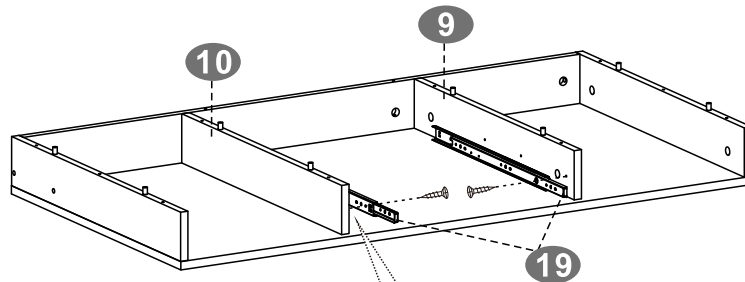

First open the slider slowly and locate the front hole



■ SCREWS

**H** 3X15 MM

X2



7

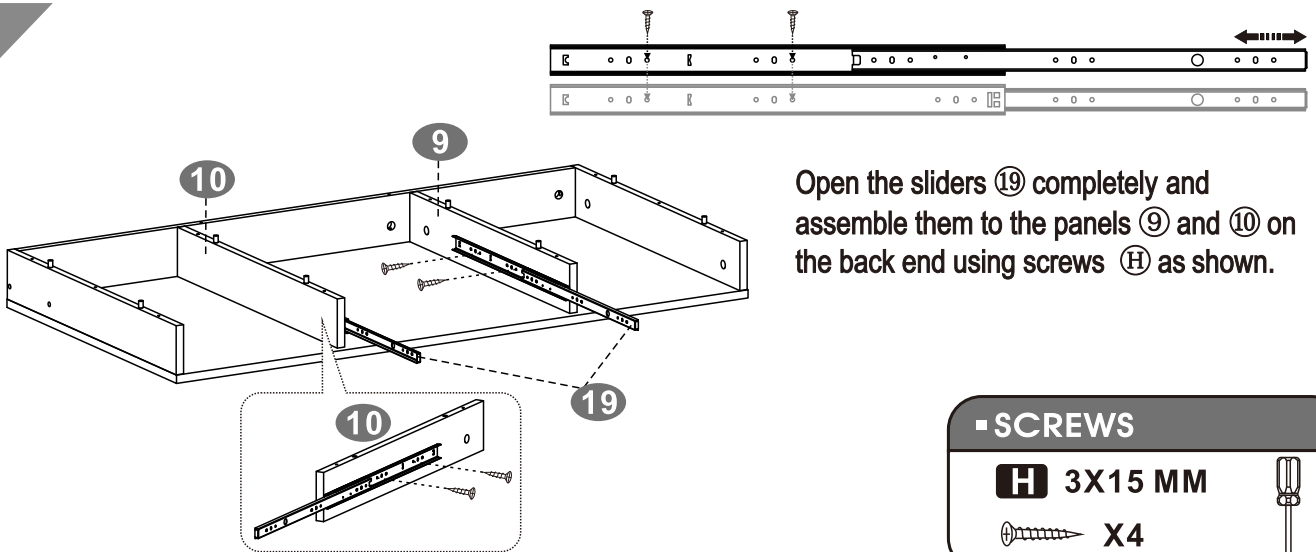

Open the sliders ⑲ completely and assemble them to the panels ⑨ and ⑩ on the back end using screws ① as shown.

**SCREWS**

**H** 3X15 MM

X4

8

Assemble the bottom panel ⑬ to panels ⑧, ⑨, ⑩, ⑪ and ⑭ using screws ② as shown.

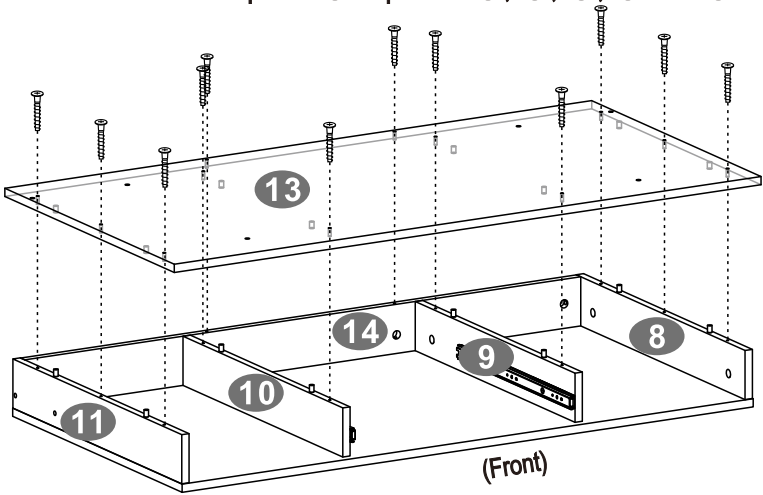

Pay attention to the orientation of panel 13: There are 2 more hole on the back.

**TWO PERSONS REQUIRED**

**SCREWS**

**F** 5X40 MM

X12

9

Assemble the main structure ② to the bottom panel ⑬ using screws ④.

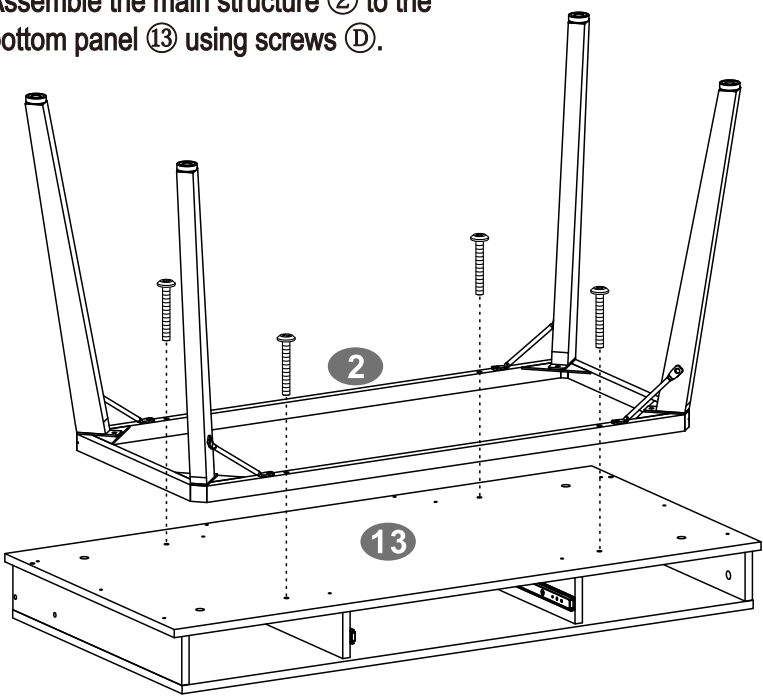

**TWO PERSONS REQUIRED**

**SCREWS**

**D** 6X40 MM

x4

10

Assemble the top shelf panel ⑮ to the upper back panel ⑯ using screws ⑰.

Pay attention to the orientation of panel 16: The cam locks must face towards the back of the unit (refer to step 11 or 14).

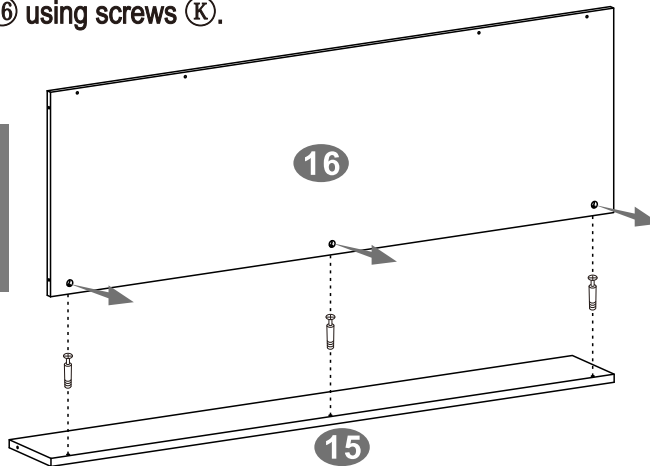

Refer to page 4

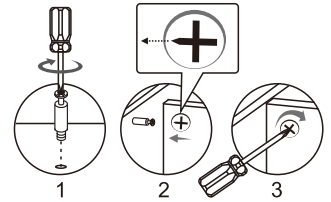

■ SCREWS

**K** 6X25 MM

Ⓚ X3



11

Assemble the side structures ⑤ to panels ⑮ and ⑯ on both sides using screws ⑱ as shown.

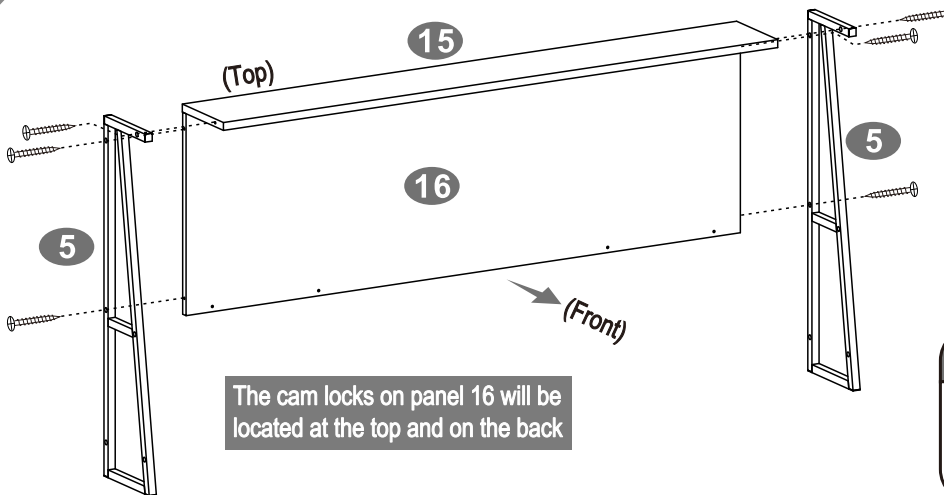

TWO PERSONS REQUIRED

The cam locks on panel 16 will be located at the top and on the back

■ SCREWS

**J** 5X45 MM

Ⓜ X6

12

Use screws ⑱ to assemble the middle side shelves ⑰ and ⑲ on their respective sides, to the upper back panel ⑯ from behind and to the side structures ⑤ from the sides as shown.

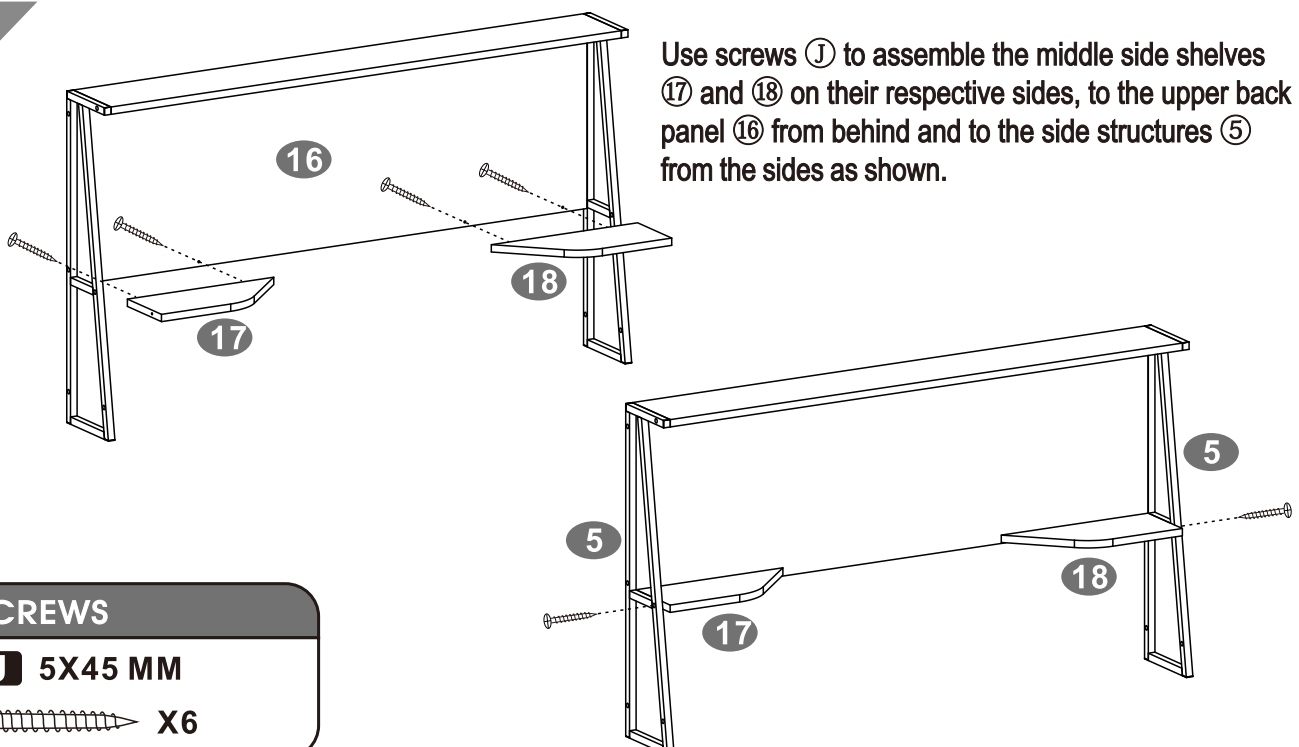

■ SCREWS

**J** 5X45 MM

Ⓜ X6

13

Assemble the accessory hanger ⑥ to the side structure ⑤ on the side of your preference using screws ⑤ from underneath.

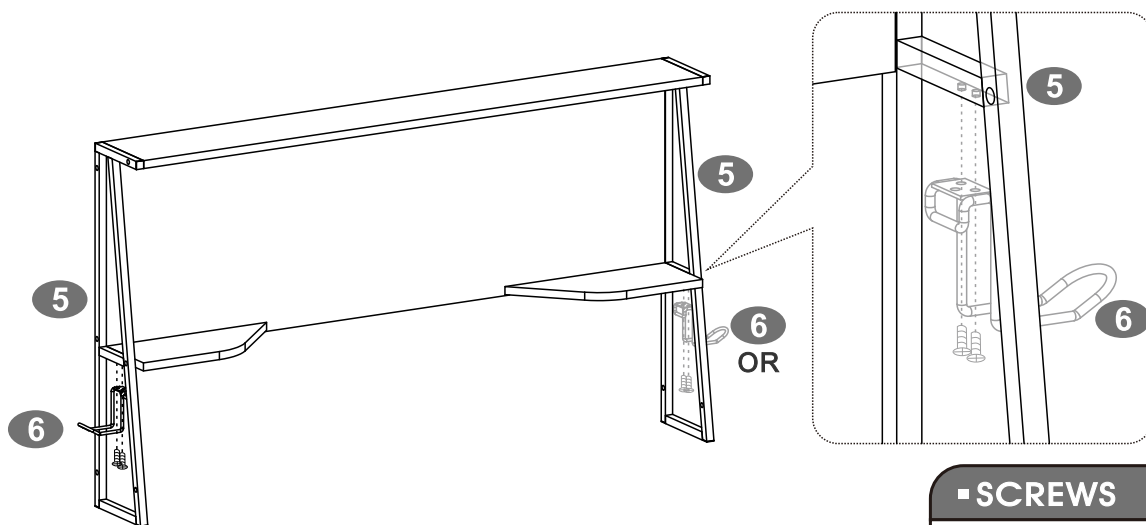

■ SCREWS

■ E 4X10 MM

● X2



14

With the help of another person, carefully turn the pieces assembled in step 9 upright into the normal position, and assemble the side structures ⑤ (from the previous step) to the bottom panel ⑬ using screws ③ from underneath as shown.

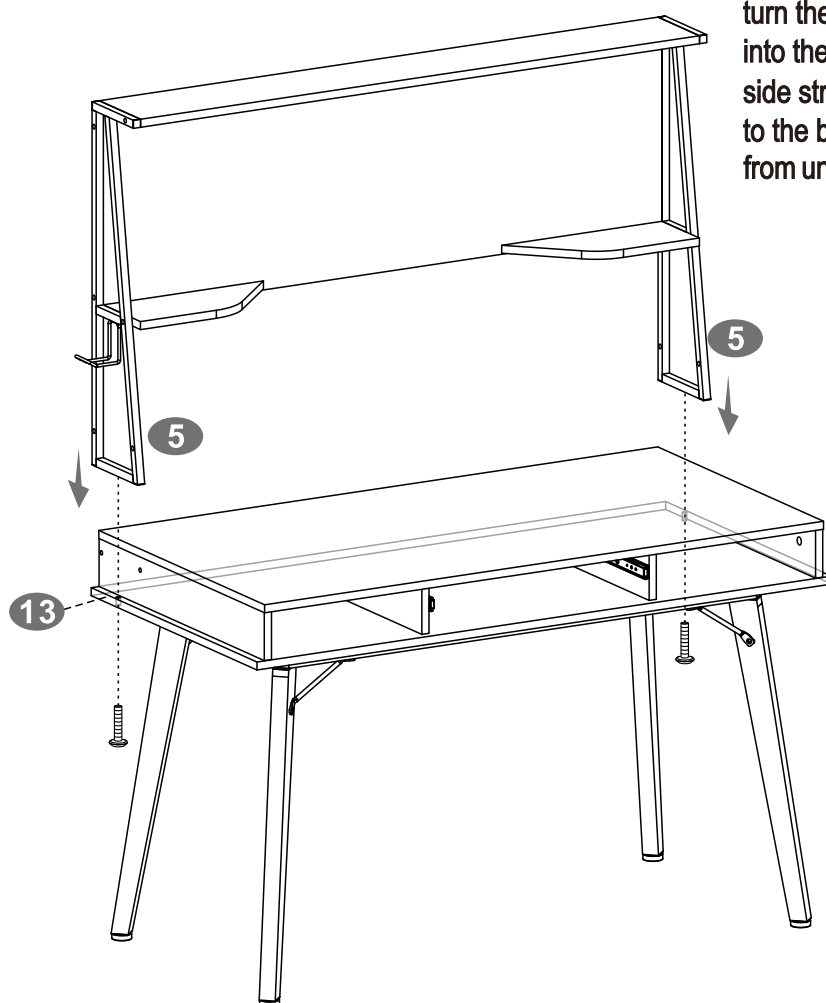

■ TWO PERSONS  
REQUIRED

■ SCREWS

■ C 6X25 MM

● x2



15

Assemble the side structures ⑤ to the side panels ⑧ and ⑪ using screws ③ as shown.

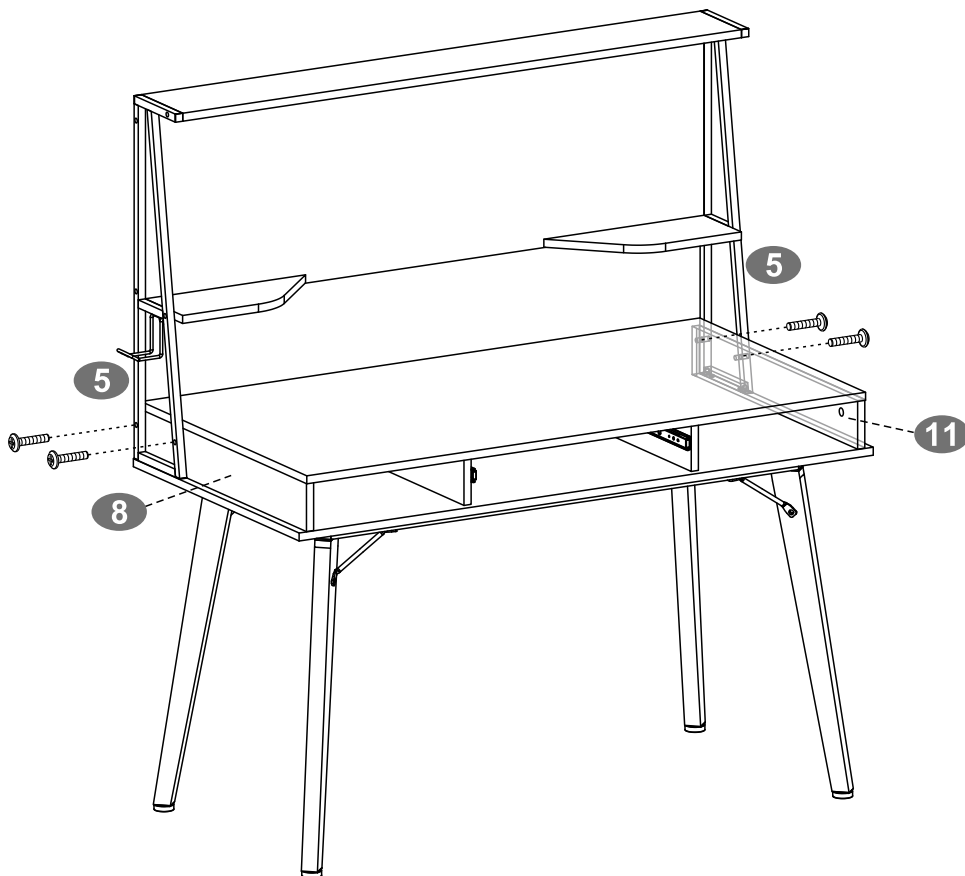

■ SCREWS

③ 6X25 MM

③ x4



16

Attach the drawer connectors ⑦ to the drawer side panels ⑳ and ㉑ using screws ④ as shown.

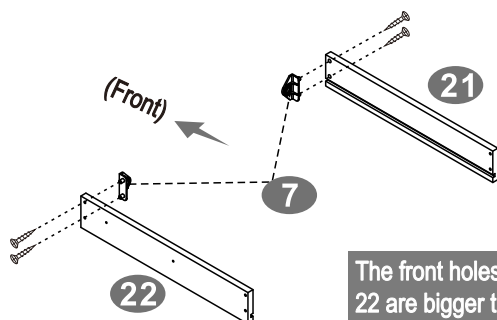

■ SCREWS

④ 3X12 MM

④ X4



17

Assemble the drawer back panel ㉔ to the side panels ㉑ and ㉒ using screws ①.

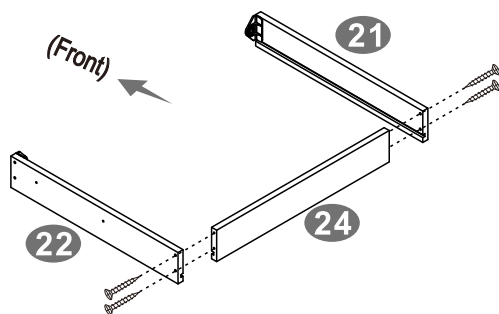

■ SCREWS

① 4X35 MM

① X4



18

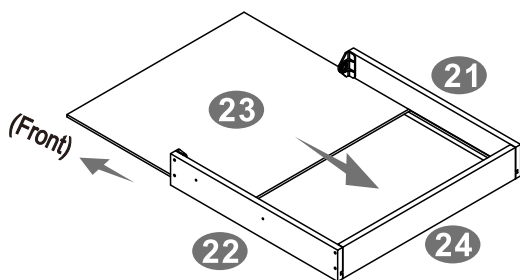

Insert the bottom panel ⑳ thru the grooves on all panels as shown.

19

Assemble the drawer front panel ㉑ to the connectors ㉒ using screws ㉓.

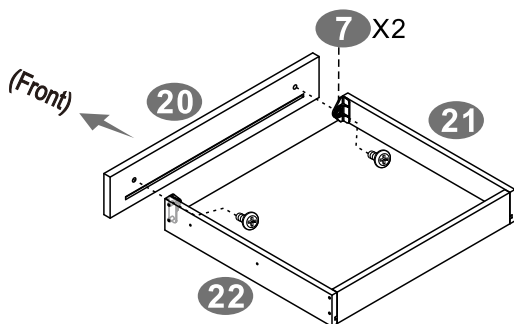

- SCREWS

**B** 6X12 MM

 x2



20

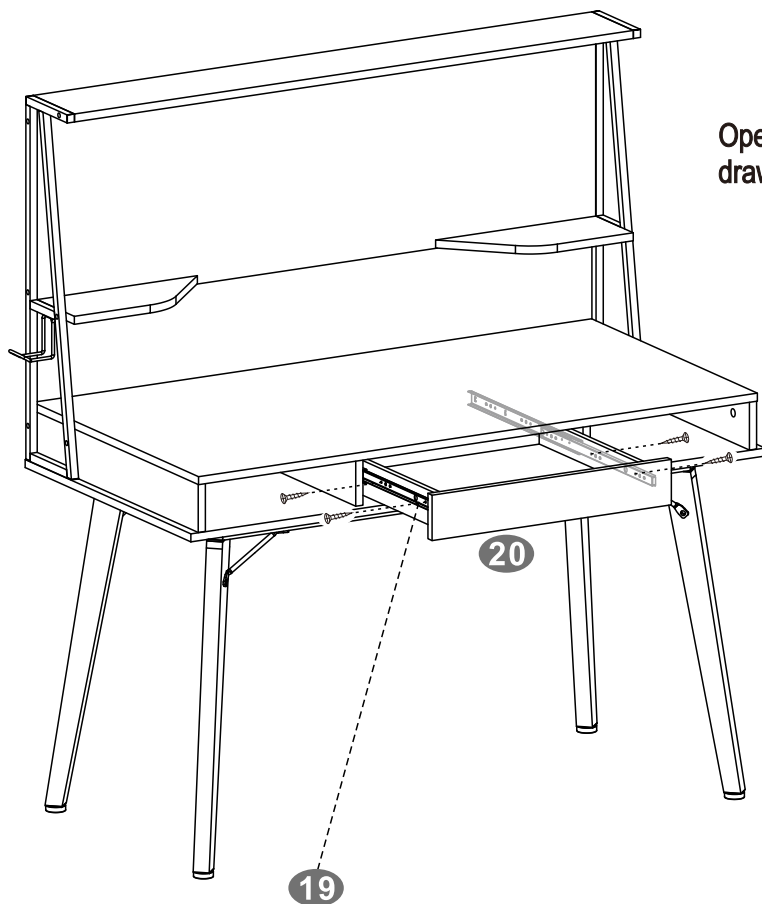

Open the sliders ㉒ and assemble the drawer using screws ㉓ as shown.

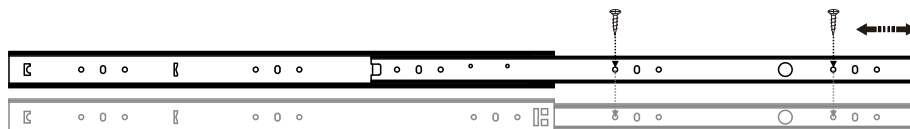

- SCREWS

**G** 3X12 MM

 X4





# ALL DONE!

Give yourself a nice pat on the back. You did a great job!

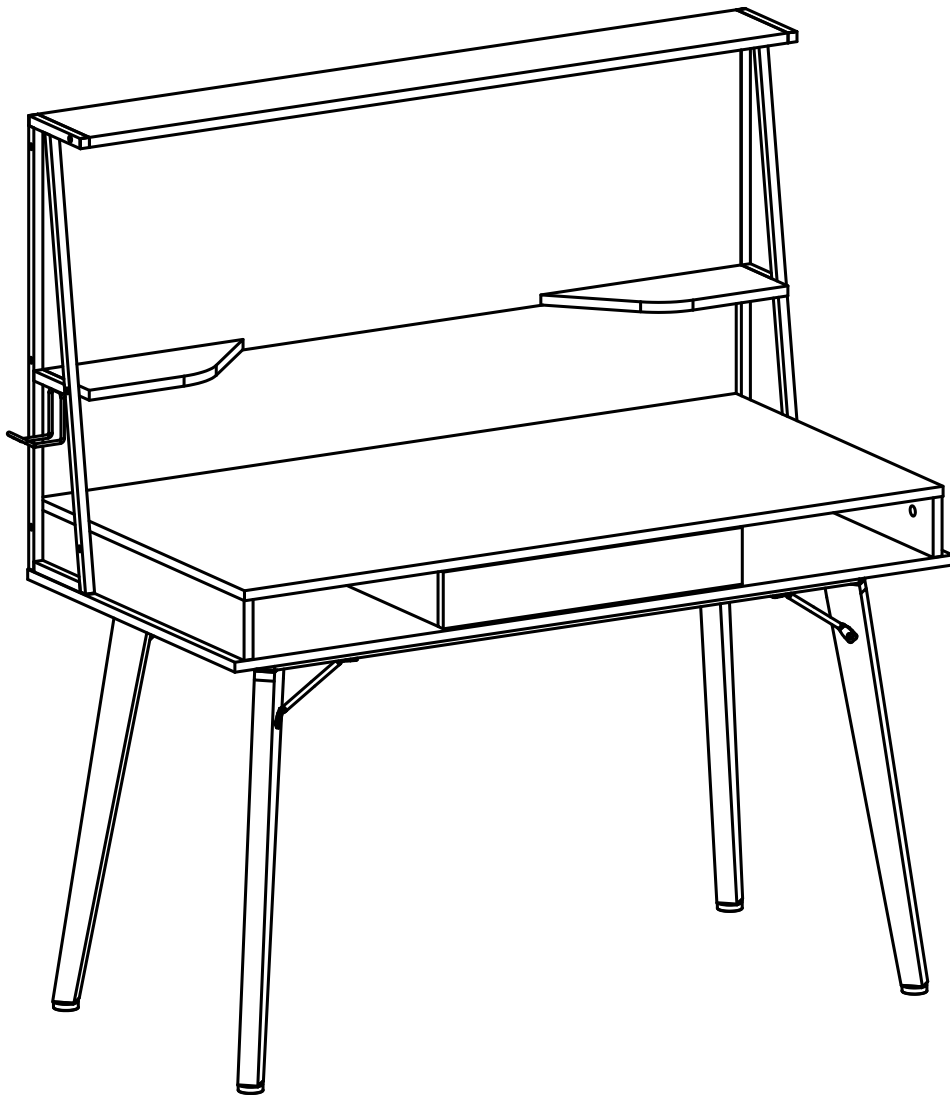

**AFTER THE ASSEMBLY IS DONE, PLEASE READ CAREFULLY THE FOLLOWING CARE AND MAINTENANCE WARNINGS:**

**WEIGHT LIMITS**

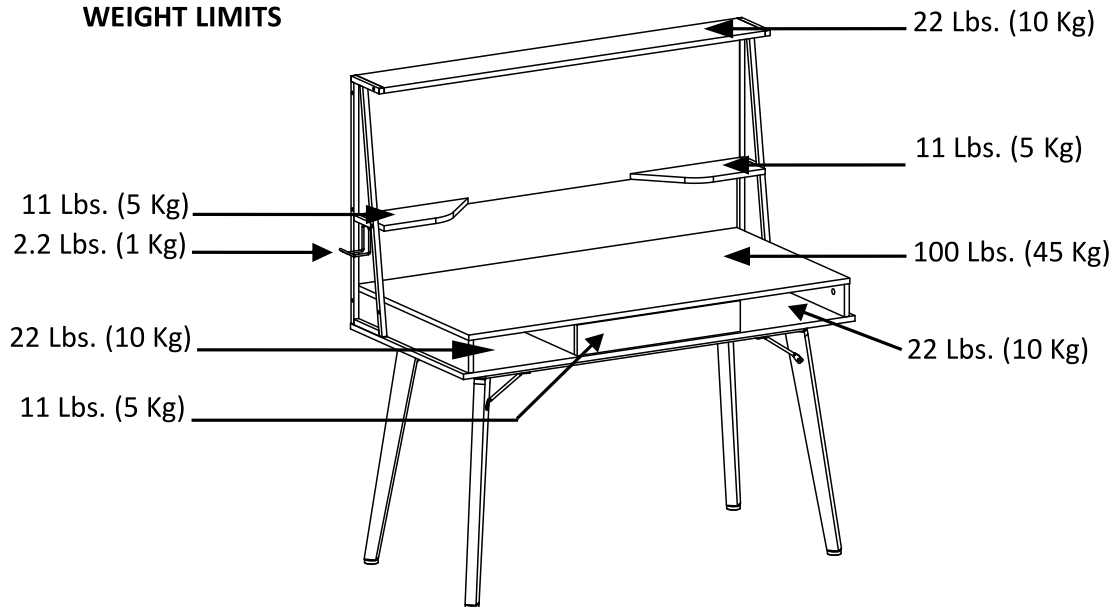

- Do not exceed the indicated weight limits.
- Do not expose the surfaces to direct sunlight or to extreme environmental conditions.
- Clean the surfaces preferable with a clean cloth damped in a solution of mild soap and water, then dry with a clean towel.
- Do not use solvents or abrasive materials to clean the unit.
- If you decide to use a cleaning agent, test first on an area hidden from view such as underneath the tabletop.
- Do not seat on the unit or lean against it.
- Do not allow small children to play under or over the unit.
- The unit must be handled by at least 2 persons when moving in the same or adjacent rooms.
- Before moving the unit, make sure to secure or remove any object that is heavy or might fall off.
- When lifting the unit, use both hands and bend your knees, not your backs.
- When transporting the unit to places far away, protect and secure the unit to avoid damage in transit. You may also disassemble it partially, please refer to steps 14 and 15.
- Shall any part of the unit become defective during the warranty period, replacement parts might be available to you at no charge. Please refer to the WARRANTY card included with the product.
- The warranty does not extend to regular wear and tear, nor the manufacturer assumes liability for damages or consequences due to accidents, incorrect assembly, negligence, improper use, modifications, or not heeding the above warnings.
- The warranty is limited to the continental United States. If you reside in Hawaii, Puerto Rico, U.S. Dependencies or other countries, please contact the supplier from where the unit was purchased.

## DESKS/LAPTOP CARTS/FILE CABINETS: LIMITED 5-YEAR WARRANTY

We warrant to the Original Purchaser who acquired a new product from us or its authorized resellers that this product will be free from defects in its workmanship and materials, under normal use and service conditions, as described herein. "Defects" as used in this warranty, is defined as any imperfections that impair the use of the furniture or product. We will replace any defective part, at its discretion, and without charge to the original purchaser other than the freight from the end consumer to us.

Replacement parts can only be supplied if parts are available. Items out of production may be unavailable. This warranty will be effective for the applicable time period beginning the date of purchase on your original sales receipt. Our obligation under this warranty is limited to repairing or replacing products or parts as provided herein. This product has been designed for and is intended for office and home-office use only. This warranty is Original Purchaser's sole remedy for product defects, and this warranty does not extend to any product, or damage to any product, caused by or attributed to abuse or misuse, products used for commercial or rental purposes, use modifications of, or attachments to the product, and products or parts not used, maintained, or extended hereunder is in lieu of any and all other warranties, express or implied, including without limitations any implied warranty or merchantability or of fitness for a particular purpose. Please note, all desks made with PVC Laminate surface should not be exposed to direct sunlight, as it may damage the material. Damage of this nature is not covered under this warranty.

We will not be responsible for indirect, special, incidental or consequential damages. This warranty is limited to merchandise purchased in the Continental United States, excludes AK, HI and PR. Some States do not allow the exclusion or limitation of incidental or consequential damages, so the above limitations or exclusions may not apply to you. This warranty gives you specific legal rights. You may also have other rights that may vary from state to state.

We will advise you of the procedure to follow in making warranty claims. The following are the procedures for warranty claims:

- a. Call us to explain the defect and give your name, address and phone number. Please have ready the model number of our product, date and place of purchase.
- b. If we determine that replacement will remedy the situation, and in order to determine the extent or the cause of the defect, purchaser will need to send the part in question at purchaser's expense. Once we receive the part, we will examine it and determine whether the claim is valid (or not), and then proceed to send the replacement. We will ship the replacement at our expense.