

# ASSEMBLY INSTRUCTIONS

STEP 1

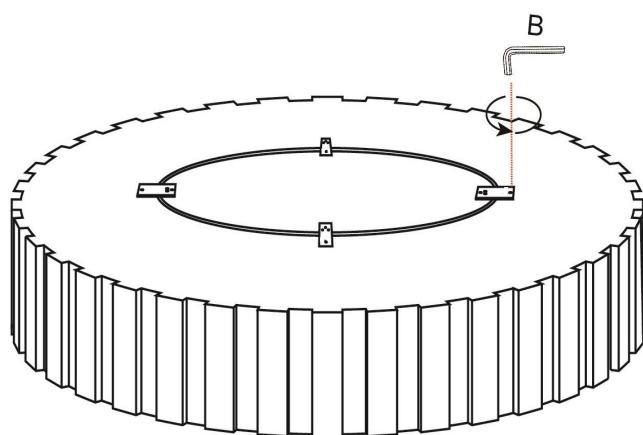

STEP 2

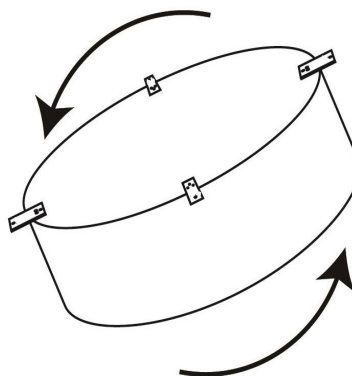

STEP 3

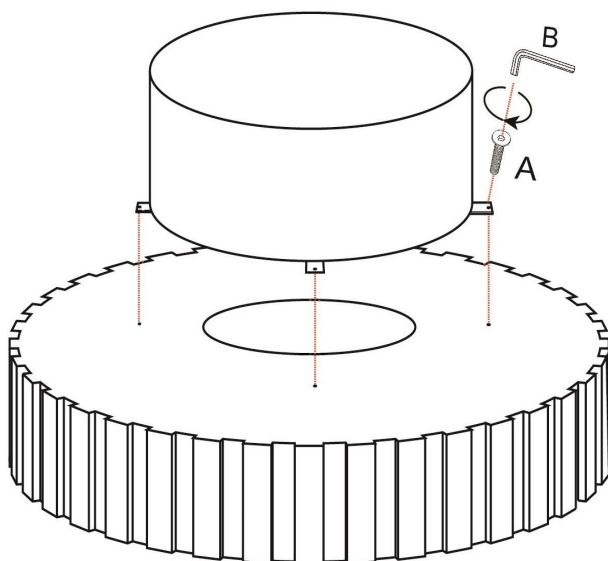

STEP 4

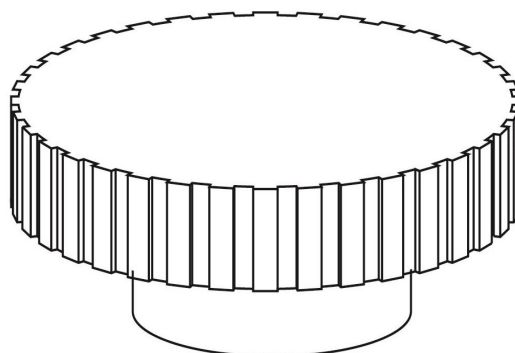

Step1: Just only unscrew all the screws locked on the desktop part.

Step 2: Remember not to rotate the table legs when taking the legs out .Please put them upside down on the desktop directly . The crew holes of the table legs should correspond to the screw holes of the.desktop .

Step3: Screw the screws into all the screw holdes and tighten them .

Attention :1.If the placement of your table results in instability or imbalance, you may use accessory D to stabilize the affected areas beneath the table in order to ensure its balance.

2.Use fittings according to the actual screw holes ,extra fittings are spares .

Ax16



Bx1



Cx4

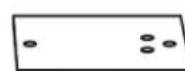

DX4

