

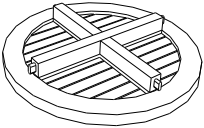
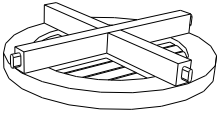
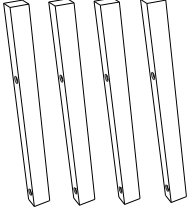

ASSEMBLY INSTRUCTIONS

Round Side Table

- Recommendations & Precautions - Prior To Assembly Completely Read These Instructions
- Unpack, inspect & identify all components & assembly materials. Assemble on flat, soft level surface to avoid marring the wood.
- We advise using the shipping box top as convenient assembly surface.
- Align each piece so that it is next to its matching color on adjoining piece.
- Check all mortise & Tenon, joints for proper fit before assembly

If anything is not to your satisfaction, you are missing hardware, or there is any concerns about the product please contact us immediately and we promise to resolve any issues immediately

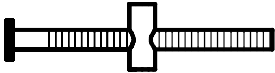
Part List		
Stool Seat	Stool Shelf	leg (4 pcs)
		

Provided Hardware (Galvanised Steel Hardware)		Tools Included	
A	Bolts = 8 sets	B	Bolts = 1 pc
			C
		Allen Wrench = 1 pc	
			

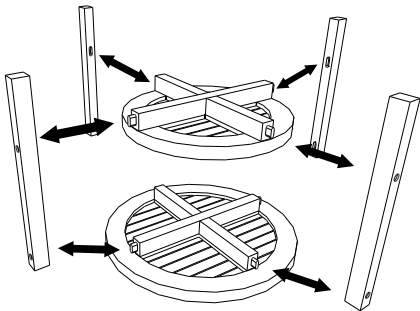

Important Additional Assembly Instruction:

1. First, completely assemble without adding any hardware, to make sure the pieces fit together properly
2. Place one side on a soft surface.
3. Insert the tenon of the top into the mortise of the leg.
4. Do point 3 for opposite leg, check that the mortise and tenon joints are all properly joined and aligned
5. Once everything is aligned, secure all component with the provided hardware, using the pre drilled holes
6. First loosely tighten each bolt until all bolts are inserted, then fully tighten each bolt one by one.
7. Carefully, move the stool into the upright position

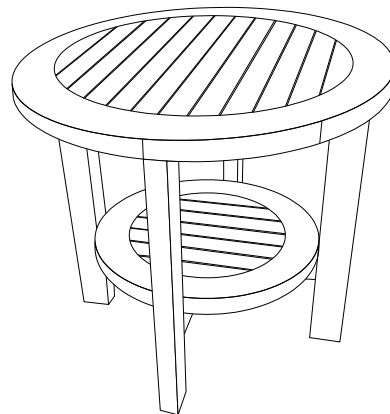
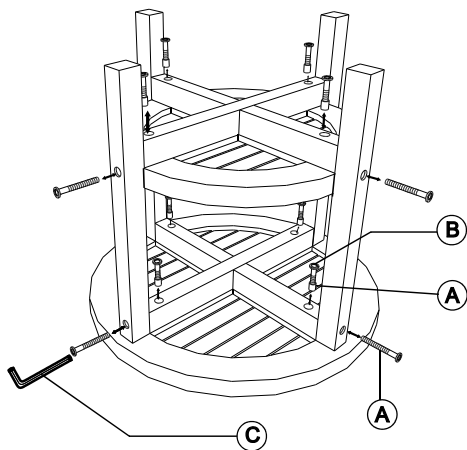

Make sure all tenon and mortise joints fit snug,
Only use pressure or a rubber mallet to apply pressure.
Do not use a hammer directly against the wood.

Thank you for your purchase. Your satisfaction is important to us ! If you are happy with this product, please honour us with your positive feedback from the channel that you purchased our product from.