



CARE AND MAINTENANCE

Wipe clean with a soft, dry cloth. Test the cleaning method on a hidden area before using them over the entire area.

NOTICE

- * Please make sure that you have all parts indicated before you begin assembly of this item.
- * This item should be assembled on a soft surface to prevent scratching the finished product during assembly.
- * This item may require periodic tightening.
- * Do not tighten bolts until completely assembled.

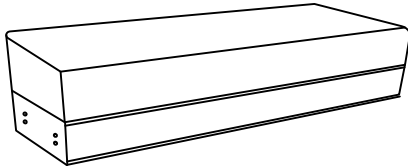
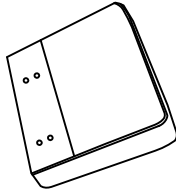
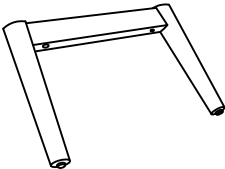
Part List and Hardware List

PIECE	DESCRIPTION	PICTURE	QUANTITY
A	Seat Cushion		1x
B	Armrest		2x
C	Frame Leg		2x
HW1	Hex Socket Bolt	 5/16" - 18 x 2"	16x
HW2	Allen key	 M5	1x

Product Dimensions: 49"W*18"D*25"H

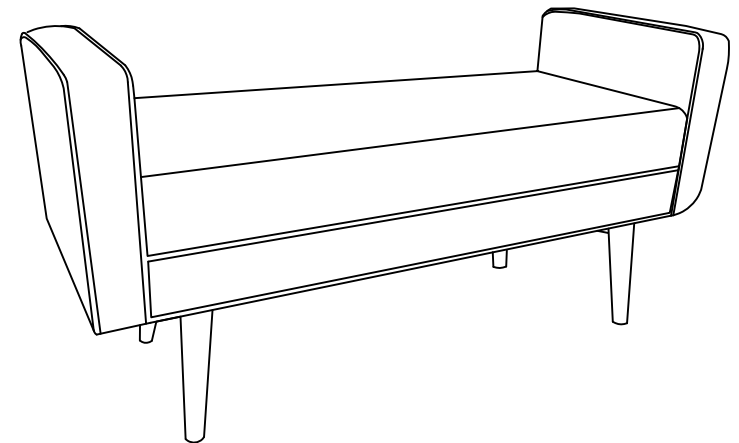

Weight capacity: 550lbs
WARNING: DO NOT STAND ON THE PRODUCT
WARNING: DO NOT OVER TORQUE BOLTS

PREPARATION

Before beginning assembly of product, make sure all parts are present. Compare parts with package contents list and hardware contents list. If any part is missing or damaged, do not attempt to assemble the product.

Estimated Assembly Time: 15 minutes.

Tools Required for Assembly (included): Allen Key

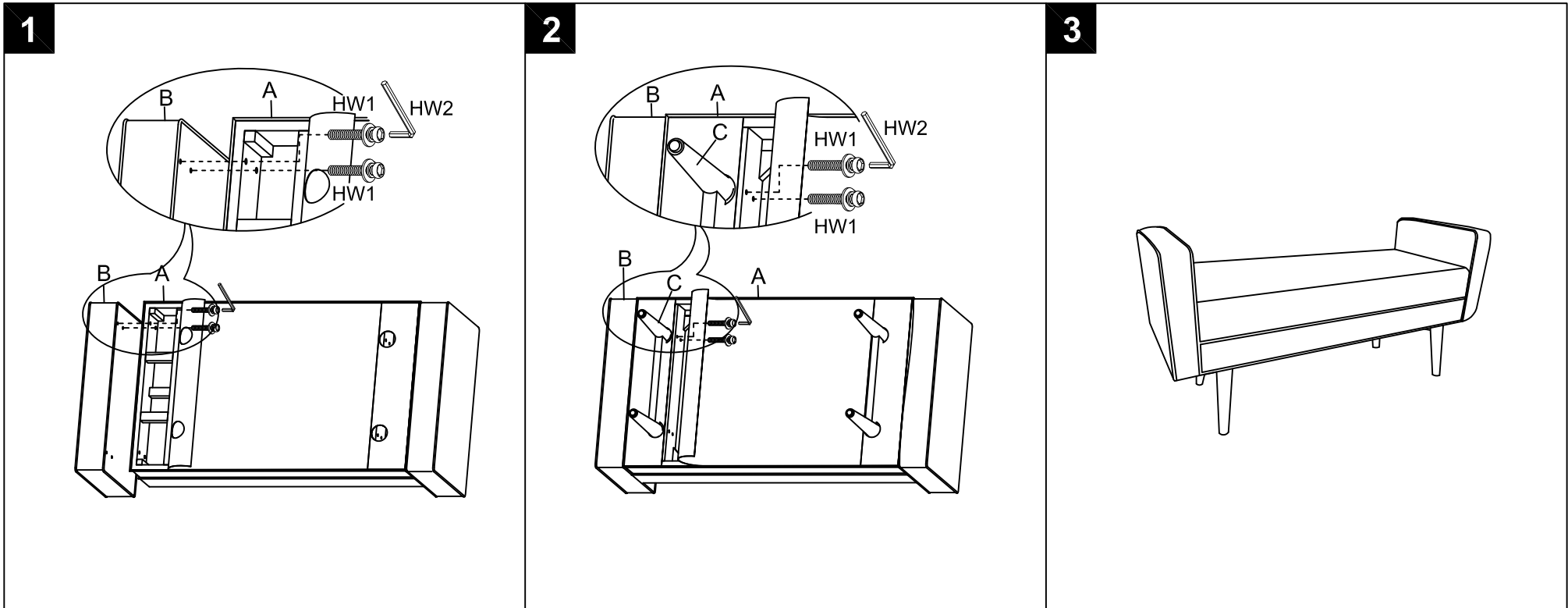

Step 1

From the left and right side of the small non-woven, Uncover Velcro on the both sides of Seat Cushion (A), Put 2*Armrest (B) on the two ends of the Seat Cushion (A) respectively, By using Allen Key (HW2) to lock with 8*Hex Socket Bolt (HW1), Then cover the Velcro back and press tight, as picture.

Step 2

For the large piece non-woven in middle, Uncover Velcro on the both sides of Seat Cushion (A), Attach 2*Frame Leg (C) in the corresponding position on the back of the Seat Cushion (A), By using Allen Key (HW2) to lock with 8*Hex Socket Bolt (HW1), Then cover the Velcro back and press tight, as picture.

Step 3

Straighten up the assembled product, Assembly is completed.