



SPECIFICATIONS

COS-DFRP488K Dual Fuel Range



Size	48 Inch / 6.6 cu. ft. Capacity
Fuel	Dual Fuel
Installation	Freestanding / Slide-In
Controls	Full Metal Knobs
Oven	Rapid Convection (Main Oven)
Material	430-Grade Stainless Steel
Electrical	240 Volts, 23 Amps
Racks	2 Racks, 5 Positions (Per Oven)
Oven Functions	Bake, Broil, Convection Bake, Light
Burners	<ul style="list-style-type: none">• Dual Ring / 20,000 BTU (x2)• Rapid / 12,000 BTU (x2)• Semi-Rapid / 9,000 BTU (x2)• Auxiliary / 6,000 BTU (x2)

COS-DFRP488K

Cosmo's COS-DFRP488K Dual Fuel Range sets a standard for high end style ranges. Cook a variety of different foods using the 8 sealed burner gas cooktop with griddle attachment and 6.6 cu. ft. electric double ovens with Standard Convection.

Features

- Designed for freestanding or slide-in
- 8 sealed gas burners & griddle attachment
- Double electric ovens
- Main oven: 4.3 cu. ft. capacity with rapid convection
- Second oven: 2.3 cu. ft. capacity with standard bake
- Full metal knobs
- Cast iron grates



Griddle



Double Oven



Metal Knobs



See Page 2 for dimensions

For more information, please visit: www.cosmoappliances.com



DIMENSIONS

COS-DFRP488K Dual Fuel Range

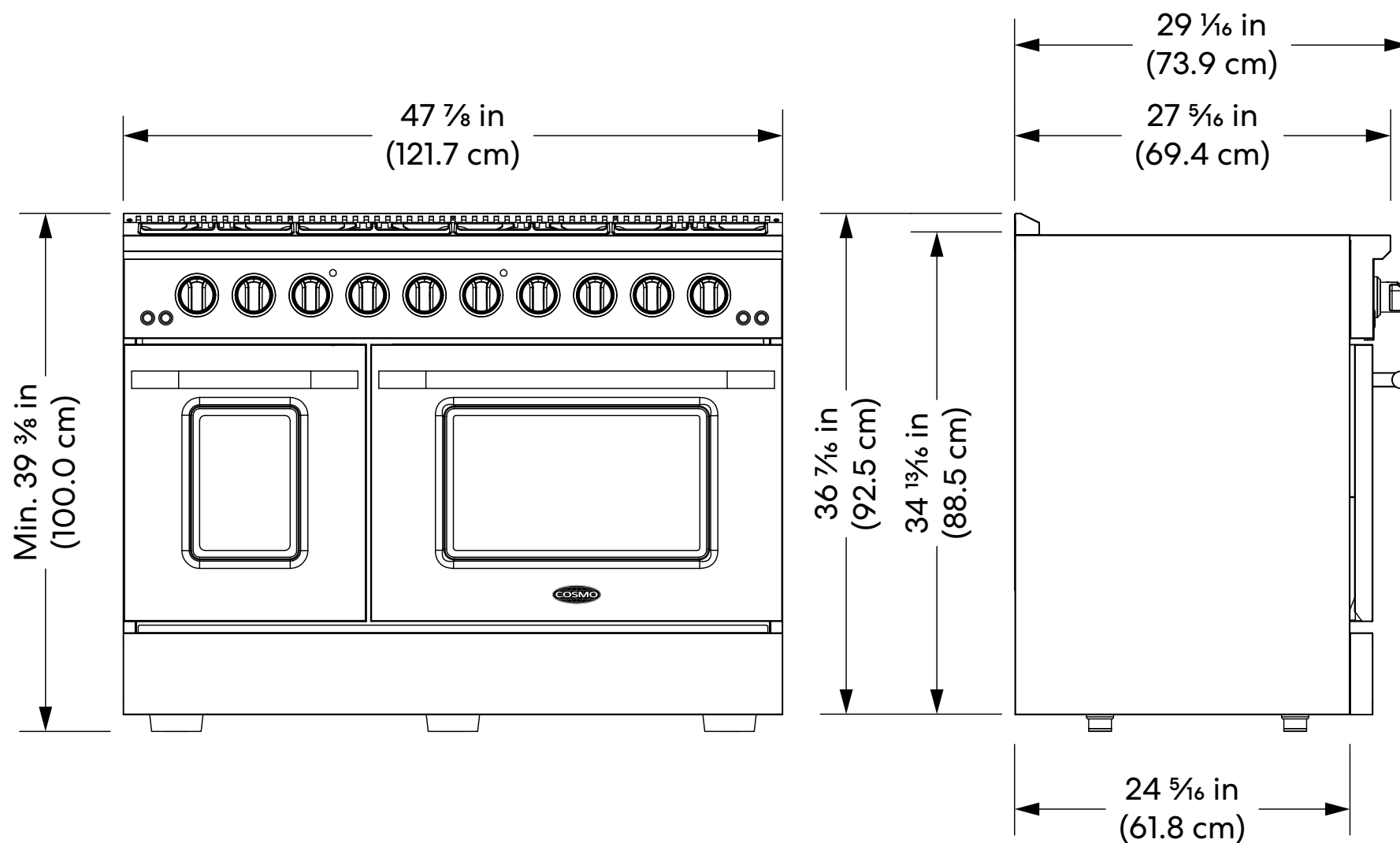
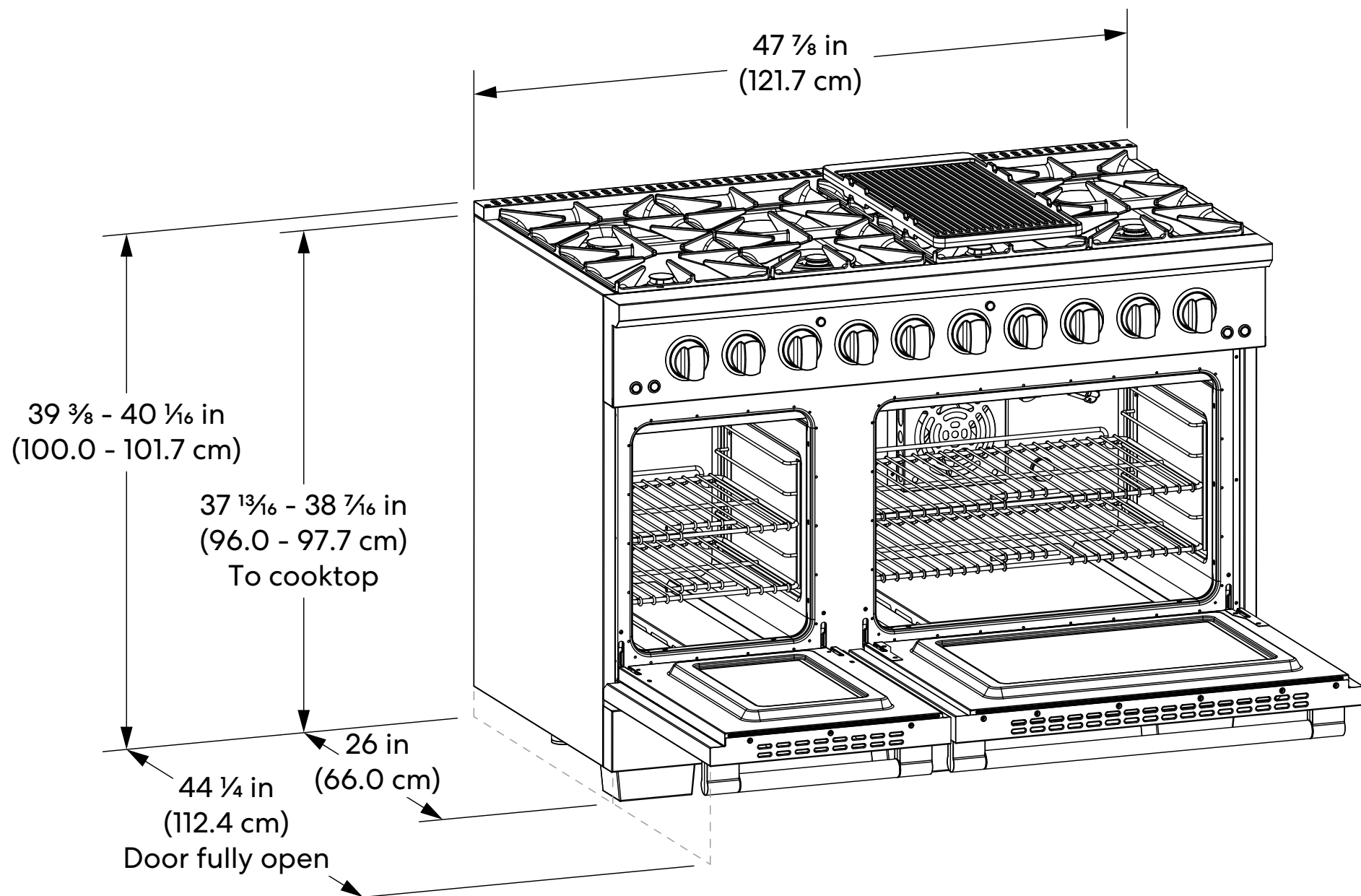

Dimensions (WxDxH): 47.9" x 27.8" x 39.4-40"