



Assembly Instructions

Thank you for purchasing this quality product. Be sure to check all packing materials carefully for small parts, which may have come loose inside the carton during shipment. Identify and count all items and compare with the PARTS LIST and/or HARDWARE LIST shown below.



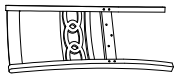
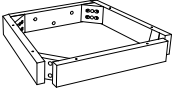
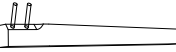

Caution: Please read the instructions thoroughly before assembly.

1. We recommend that you assemble this product with the assistance of another person; this will make the assembly easier, and will help eliminate damage to the product or injury to persons during assembly.
2. Please do not over tighten screws or bolts until the assembly is completed.
3. Please put all parts on a non-abrasive floor before assembly, and follow the assembly steps to assemble your newly purchased product correctly and efficiently.

PARTS LIST

NO.	COMPONENT	SKETCH	QTY.
A	CHAIR BACK		4 PCS
B	SEAT FRAME		4 PCS
C	FRONT LEG		8 PCS
D	CUSHION SEAT		4 PCS

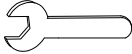
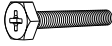
HARDWARE LIST

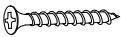
NO.	COMPONENT	SKETCH	QTY.
1	FLAT WASHER 5/16" DIA.		44 PCS
2	SPRING WASHER 5/16" DIA.		44 PCS
3	NUT 5/16" DIA.		16 PCS
4	ALLEN WRENCH 5/16" DIA.		1 PC
5	SHORT BOLT 1/4" x 1 3/4"		12 PCS
6	LONG BOLT 1/4" x 3"		16 PCS
7	WOOD SCREW 5/32" x 1 1/2"		24 PCS

Assembly Instructions

To assemble the chairs, please follow the following steps and repeat for each chair:

STEP 1

Lay the chair back on soft clean surface and install the seat frame.

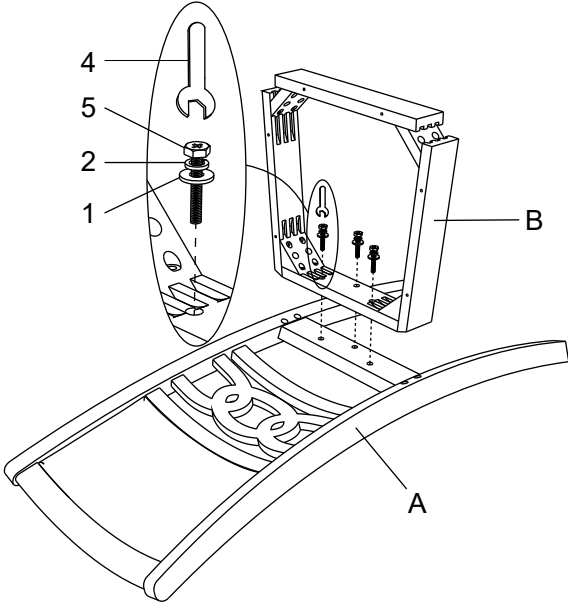

STEP 2

Insert long bolts to secure the seat frame.

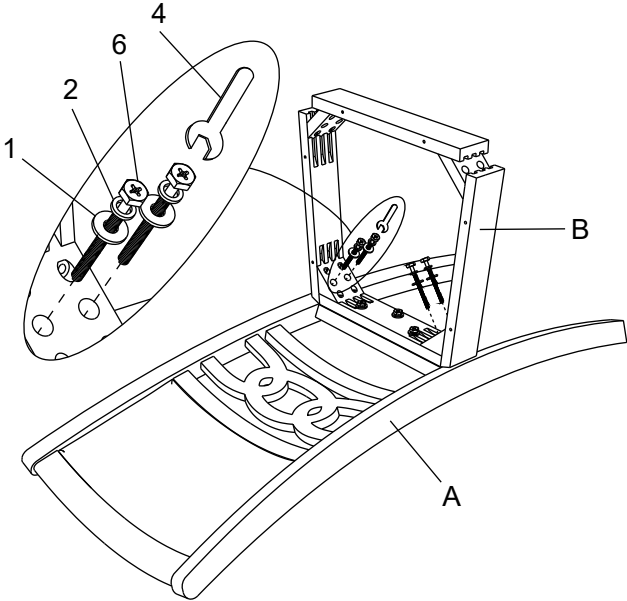

STEP 3

Install the chair front legs once the seat frame is secured.

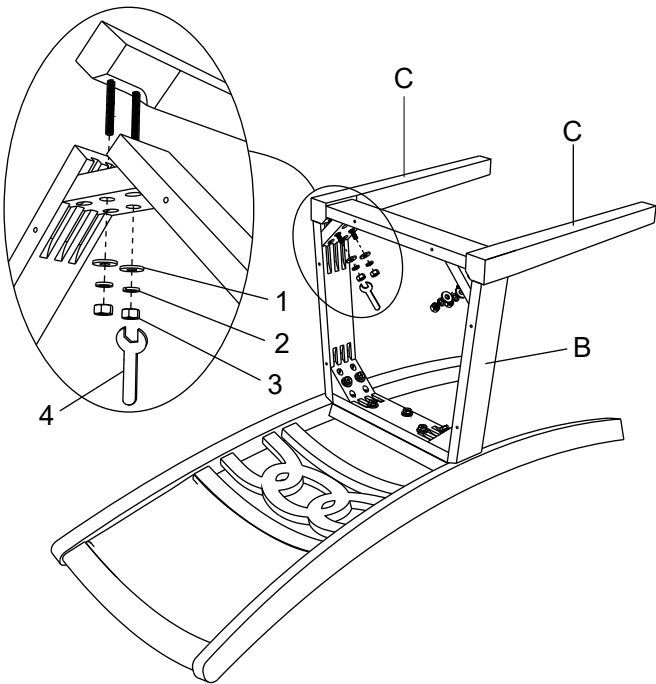

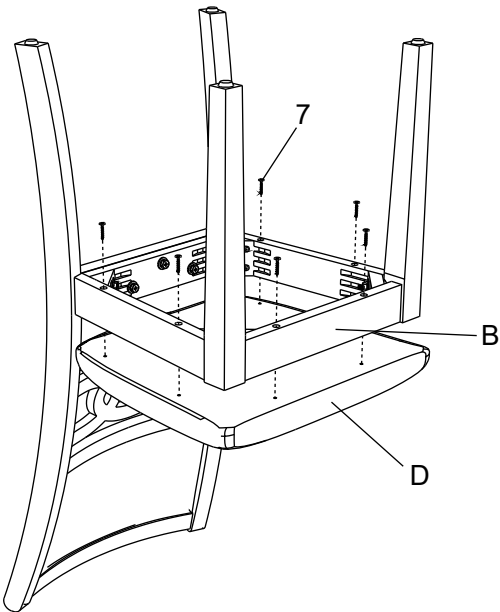

STEP 4

Place the assembled seat frame on the cushion seat and attach with wood screws.







Assembly Instructions

PARTS LIST

NO.	COMPONENT	SKETCH	QTY.
A	TABLE TOP		1 PC
B	TABLE LEG		4 PCS

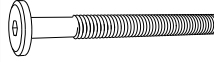
HARDWARE LIST

NO.	COMPONENT	SKETCH	QTY.
1	FLAT WASHER 5/16" DIA.		8 PCS
2	SPRING WASHER 5/16" DIA.		8 PCS
3	BOLT 5/16" x 60 MM		8 PCS
4	ALLEN KEY 4 MM		1 PC

To assemble the table, please follow the following step:

