

# ASSEMBLY INSTRUCTIONS

## Description : Full Bed

Thank you for purchasing this quality product. Be sure to check all packing material carefully for small part that may have come loose inside carton during shipment.

**Applicable Folding Mattress Size: +- 54" x 25" x 18"**  
**(Unfolded Size +- 54" x 75" x 6")**

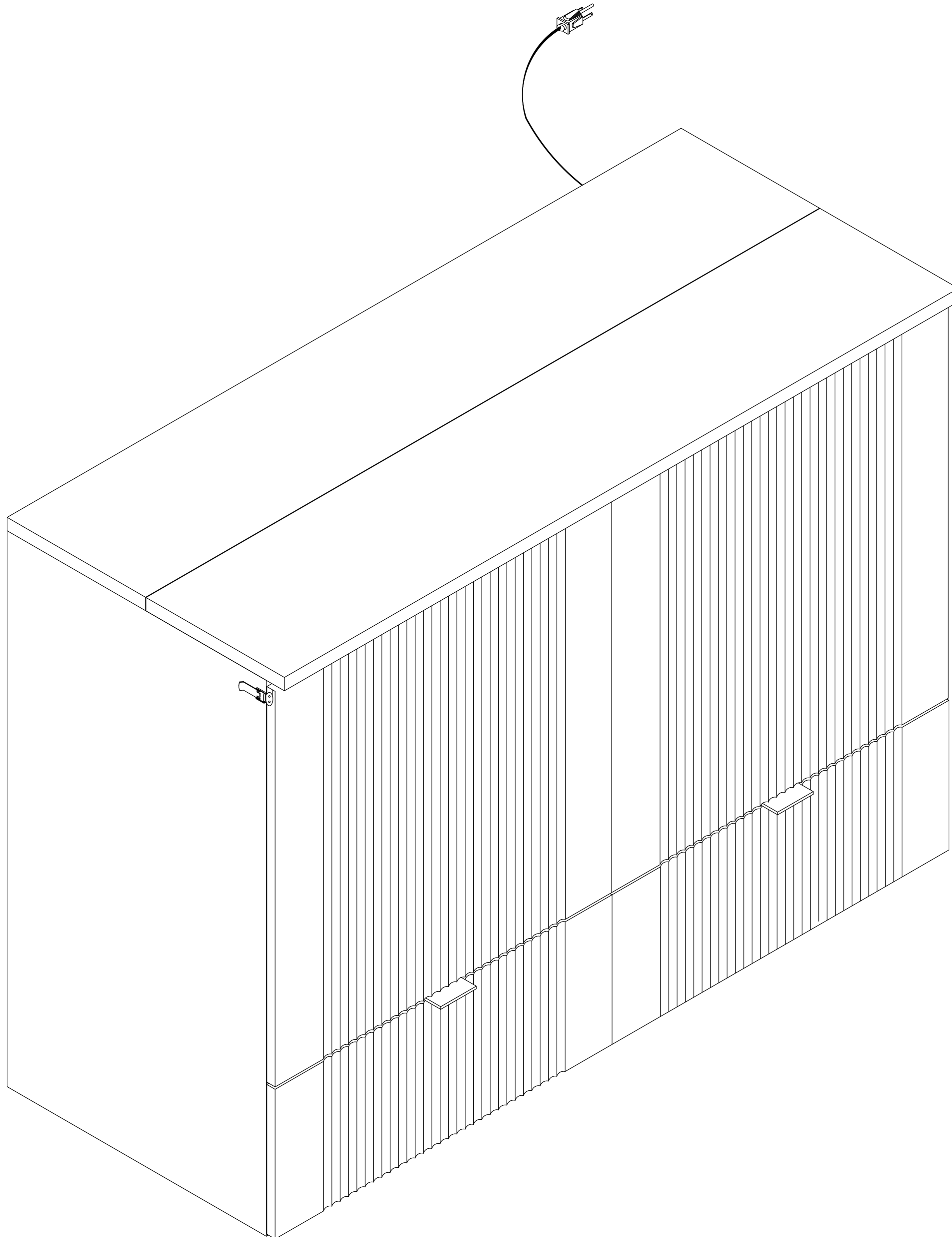

# ASSEMBLY INSTRUCTIONS

## Description : Full Bed

Thank you for purchasing this quality product. Be sure to check all packing material carefully for small part that may have come loose inside carton during shipment.

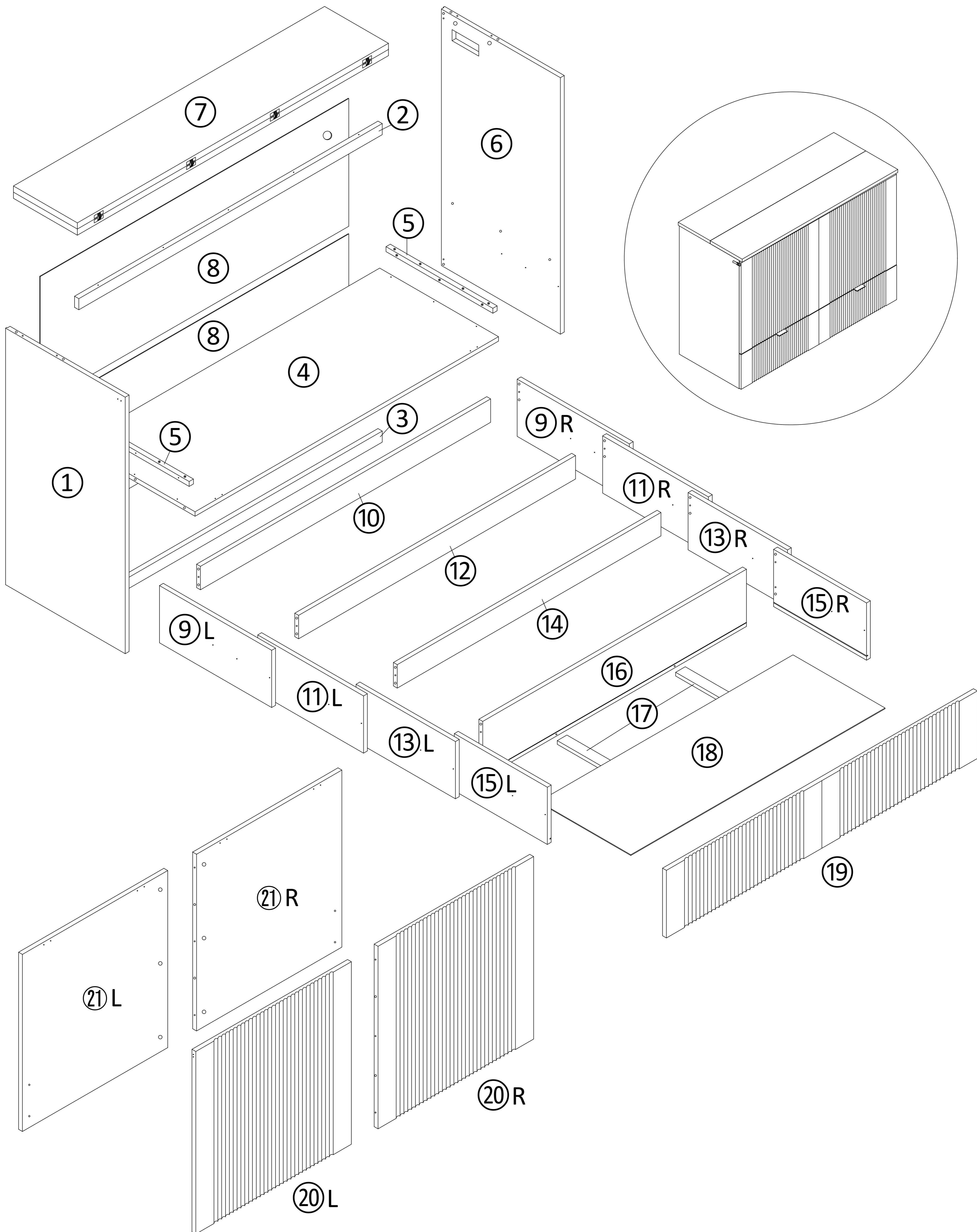

**PART LIST & HARDWARE LIST (BOX 1)**

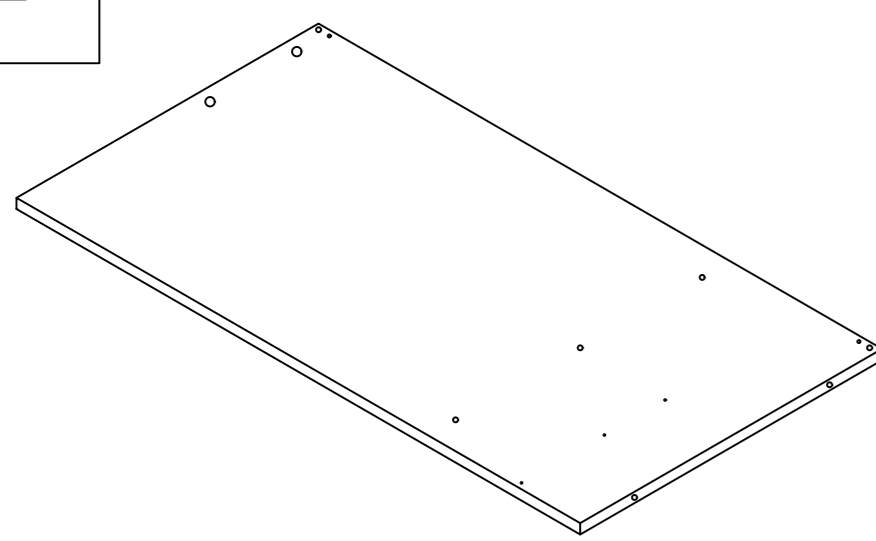
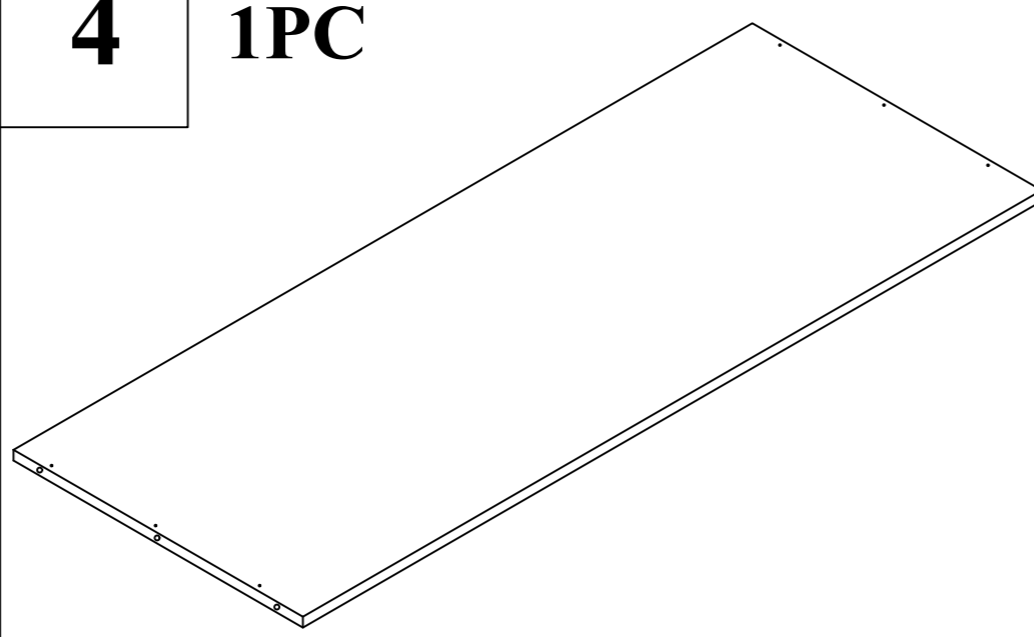
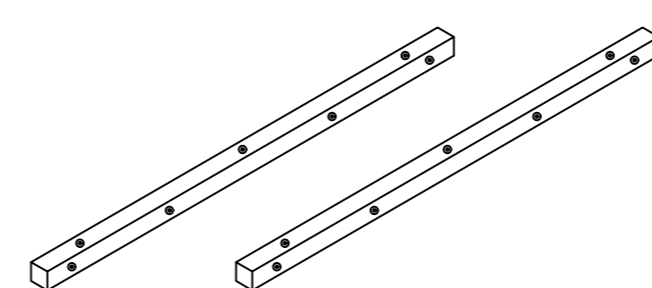
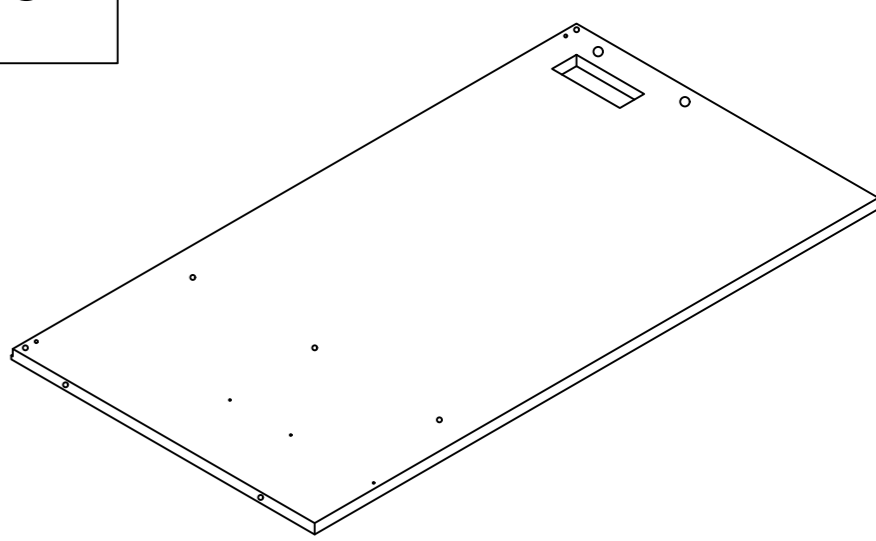
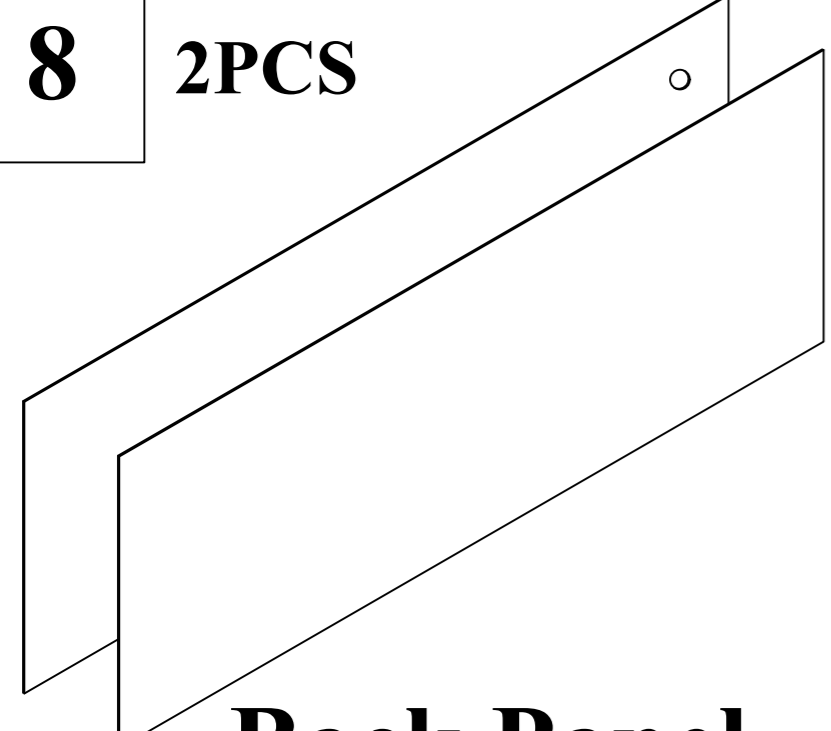
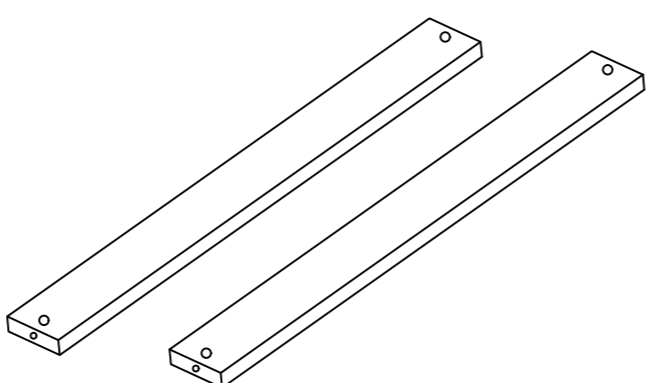
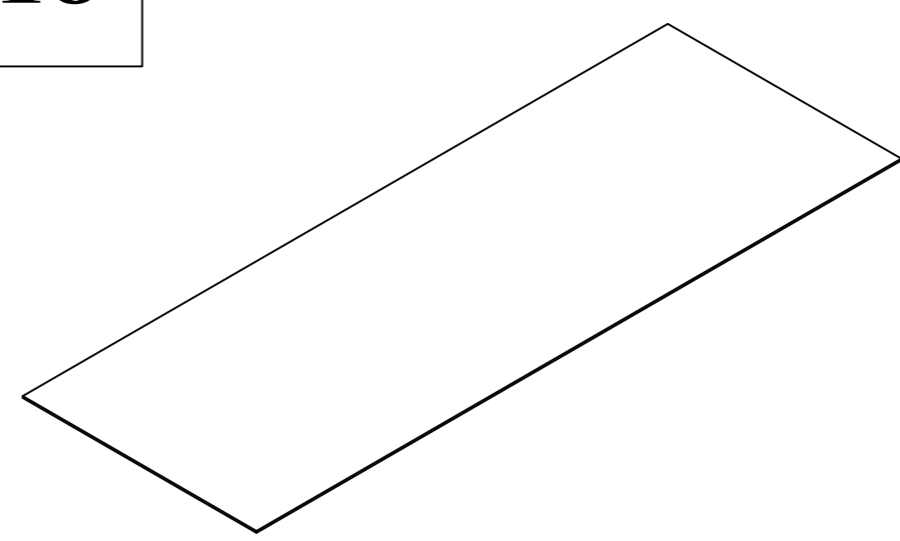
<p><b>1</b> 1PC</p>  <p align="center"><b>Left Panel</b></p>	<p><b>4</b> 1PC</p>  <p align="center"><b>Bottom Panel</b></p>	<p><b>5</b> 2PCS</p>  <p align="center"><b>Connection Rail</b></p>	<p><b>6</b> 1PC</p>  <p align="center"><b>Right Panel</b></p>
<p><b>8</b> 2PCS</p>  <p align="center"><b>Back Panel</b></p>	<p><b>17</b> 2PCS</p>  <p align="center"><b>Drawer Base Support</b></p>	<p><b>18</b> 1PC</p>  <p align="center"><b>Drawer Base</b></p>	

**PART LIST & HARDWARE LIST (BOX 2)**

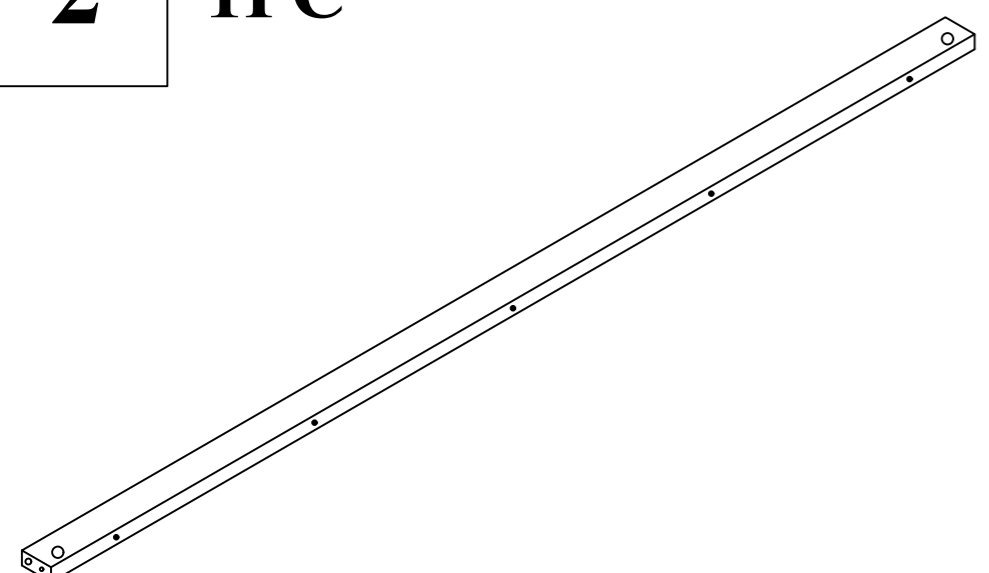
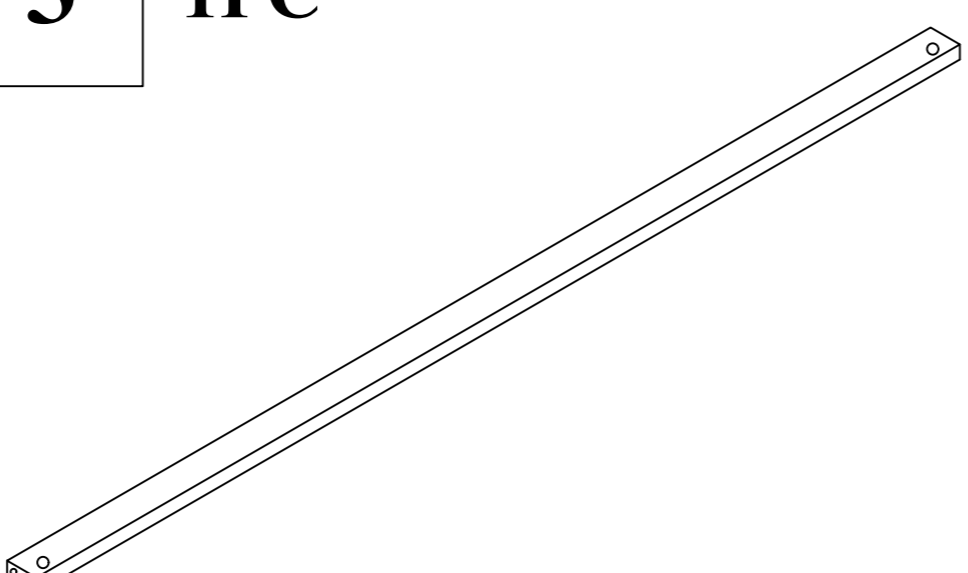
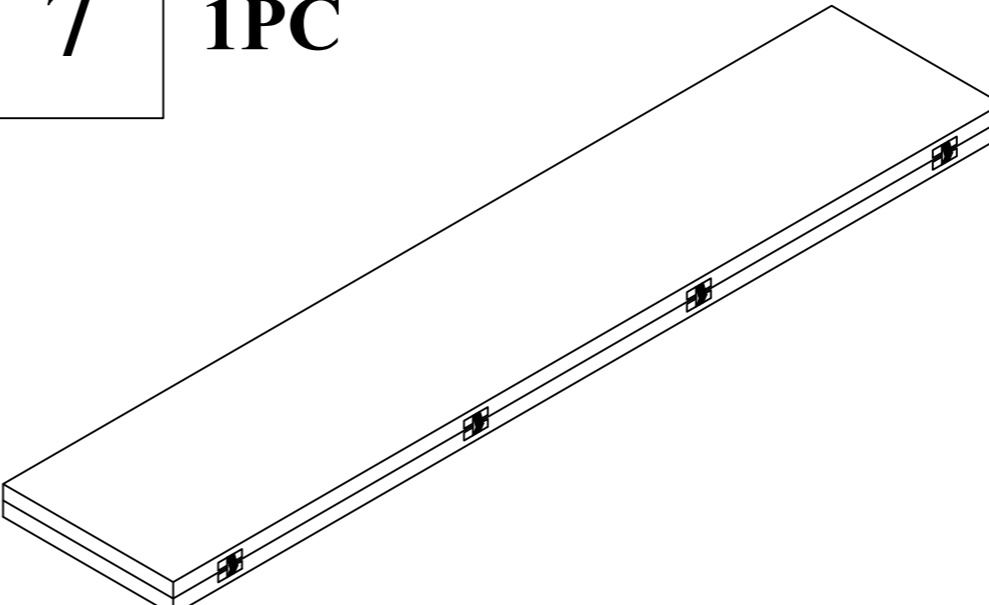
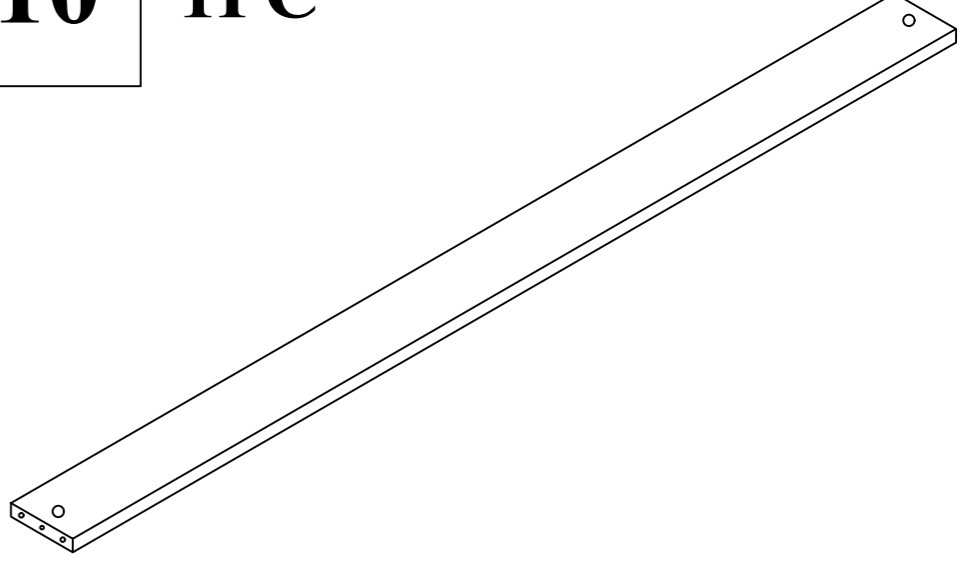
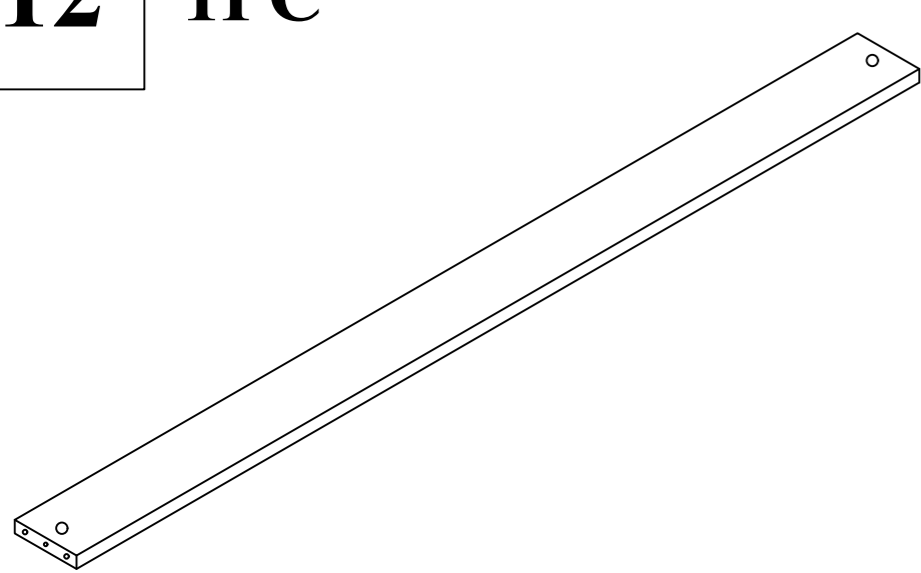
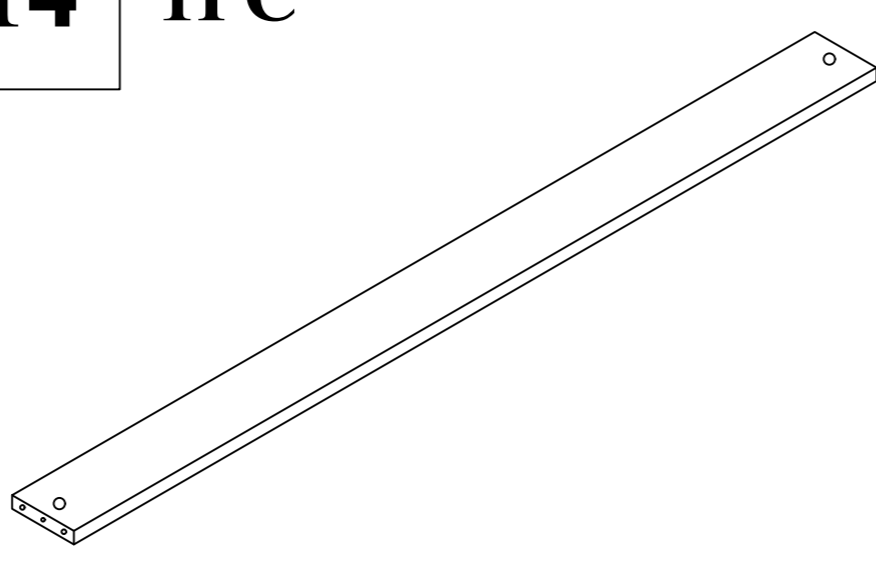
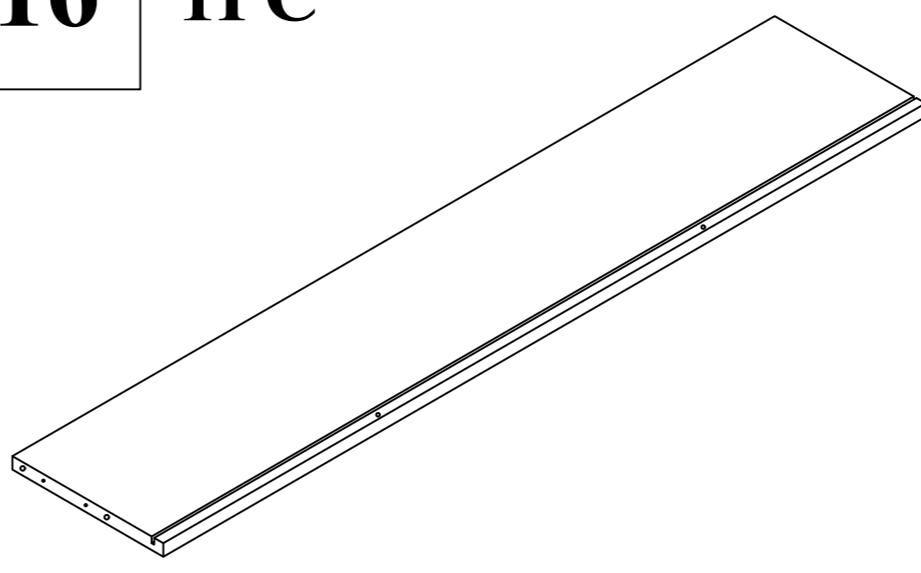
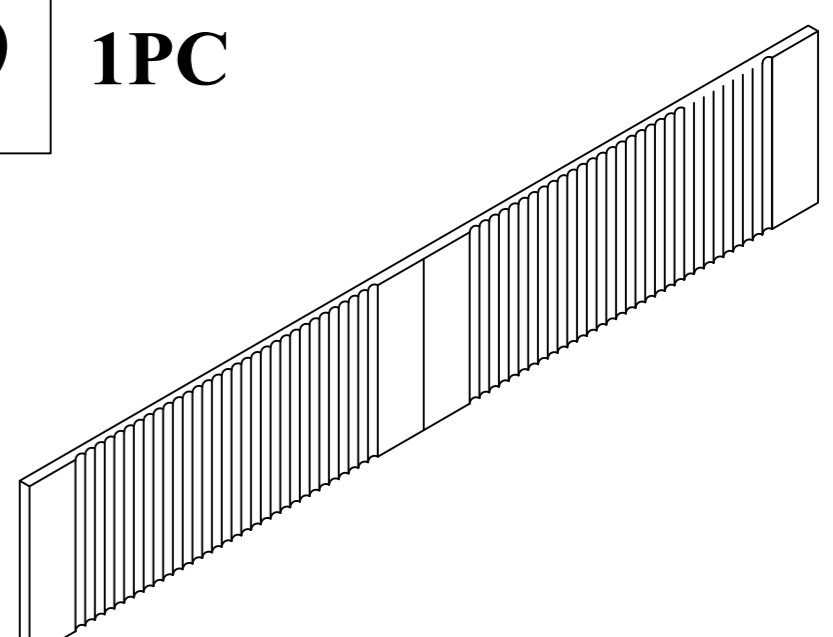
<p><b>2</b> 1PC</p>  <p align="center"><b>Top Rail</b></p>	<p><b>3</b> 1PC</p>  <p align="center"><b>Bottom Rail</b></p>	<p><b>7</b> 1PC</p>  <p align="center"><b>Top Panel</b></p>	<p><b>10</b> 1PC</p>  <p align="center"><b>Extension Back 1</b></p>
<p><b>12</b> 1PC</p>  <p align="center"><b>Extension Back 2</b></p>	<p><b>14</b> 1PC</p>  <p align="center"><b>Extension Back 3</b></p>	<p><b>16</b> 1PC</p>  <p align="center"><b>Drawer Back</b></p>	<p><b>19</b> 1PC</p>  <p align="center"><b>Drawer Face</b></p>

**PART LIST (BOX 3)**

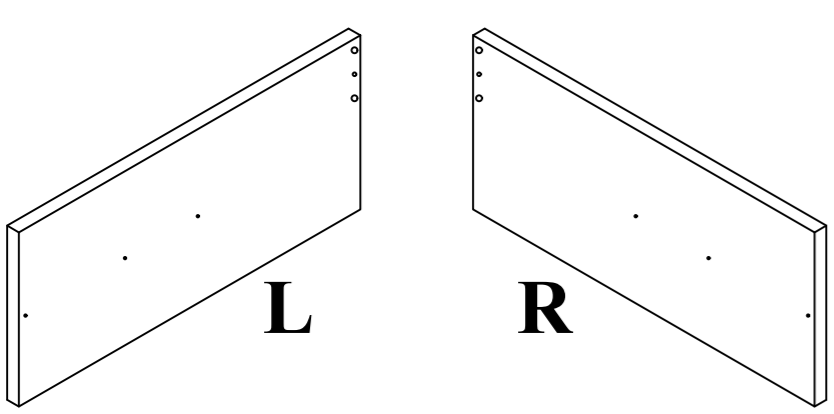
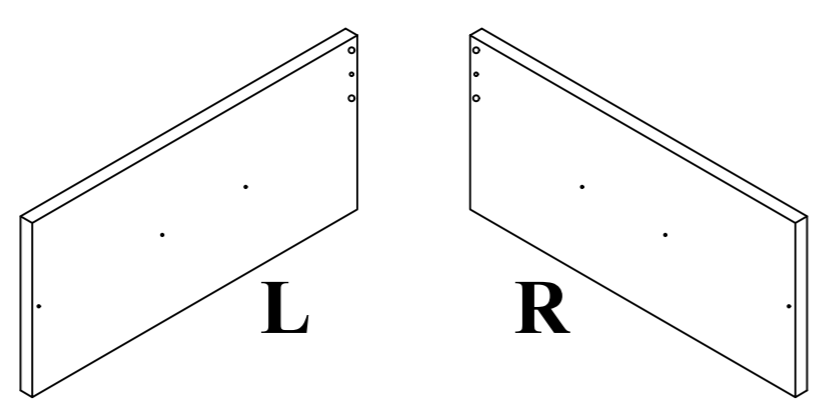
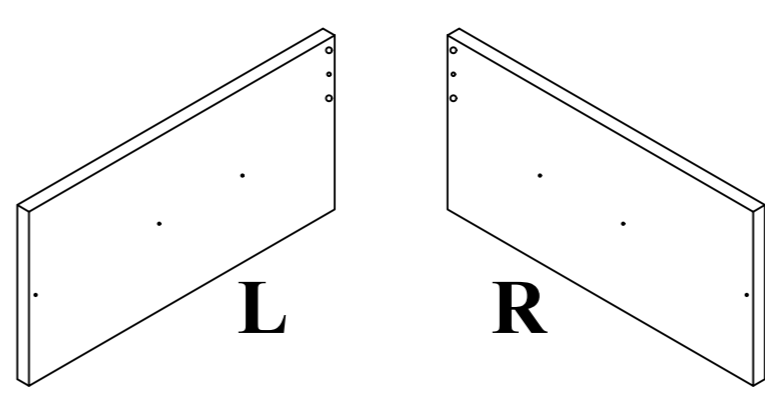
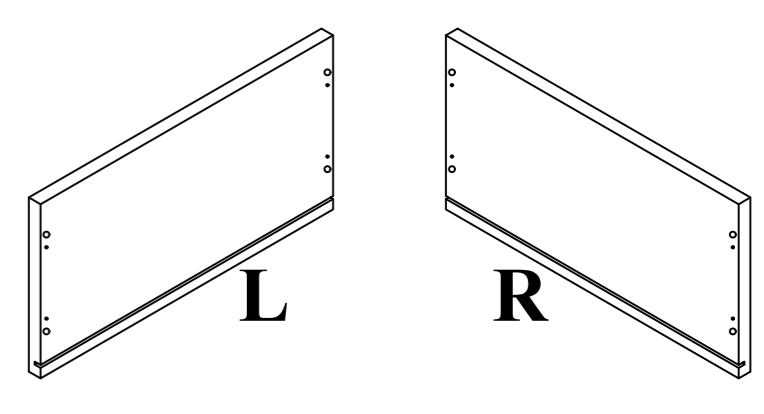
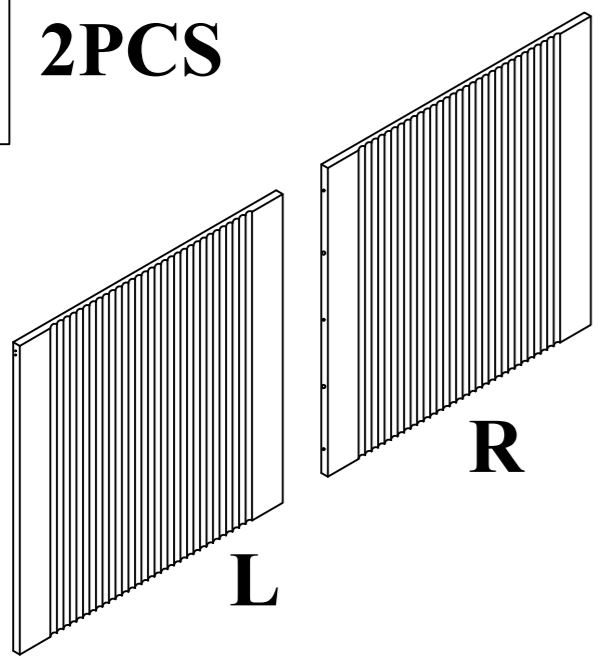
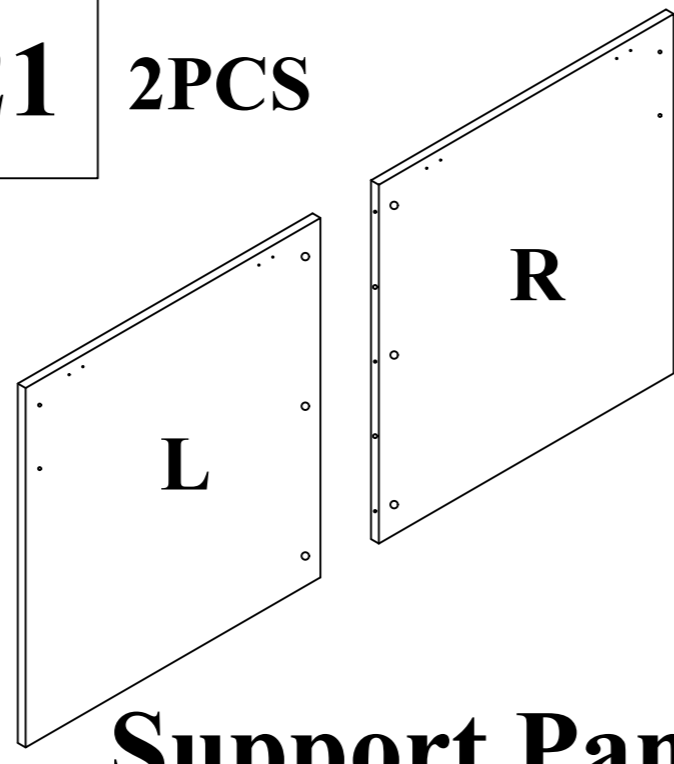
<p><b>9</b> 2PCS</p>  <p align="center"><b>Extension Side 1</b></p>	<p><b>11</b> 2PCS</p>  <p align="center"><b>Extension Side 2</b></p>	<p><b>13</b> 2PCS</p>  <p align="center"><b>Extension Side 3</b></p>	<p><b>15</b> 2PCS</p>  <p align="center"><b>Drawer Side</b></p>
<p><b>20</b> 2PCS</p>  <p align="center"><b>Door Panel</b></p>	<p><b>21</b> 2PCS</p>  <p align="center"><b>Support Panel</b></p>		

Hardware list as below. Be sure to check all packing material carefully for small part that may have come loose inside carton during shipment. Apply a battery screw machine for better assembly experience. You are encouraged to get help from at least one person to assembly. This assembly will take around 60minutes.

### HARDWARE LIST (BOX 1)

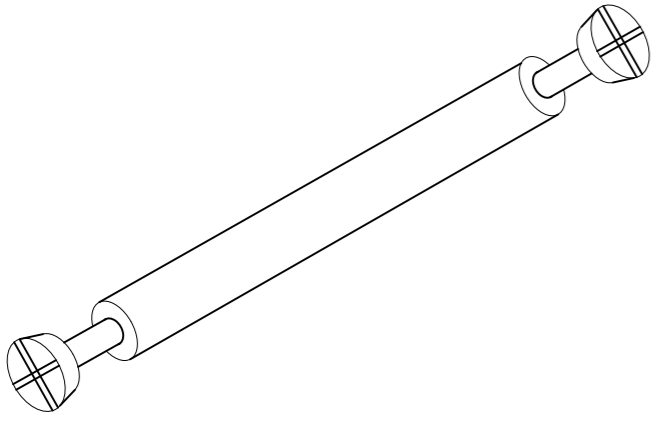
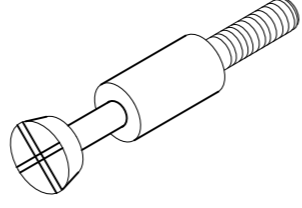
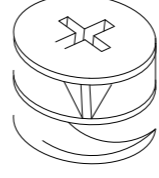
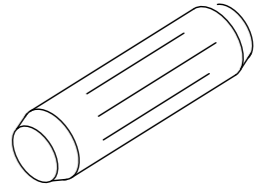
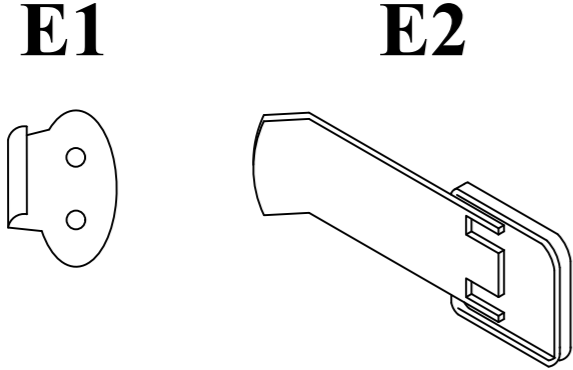
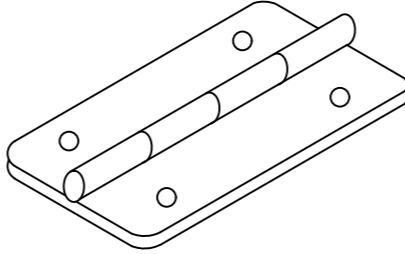
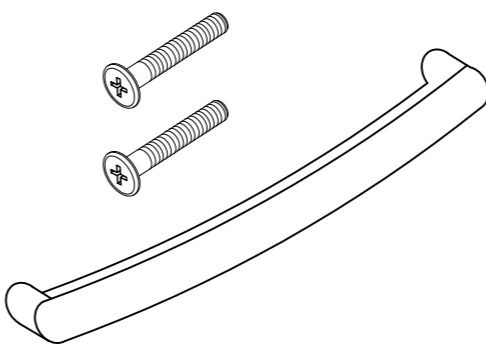
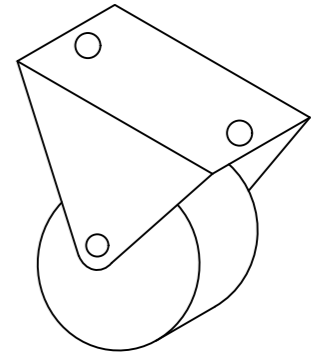
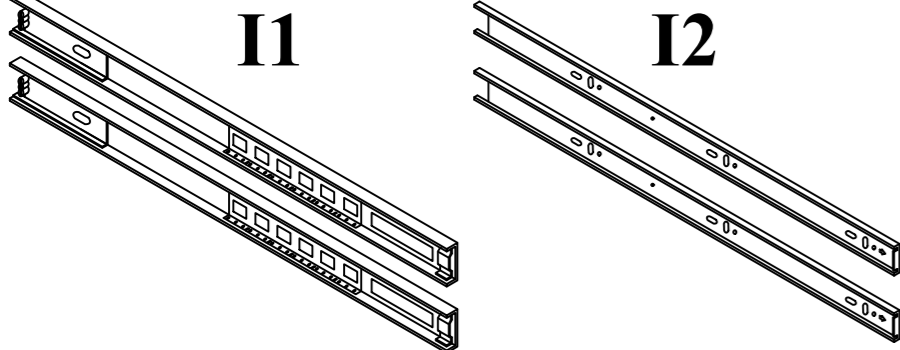
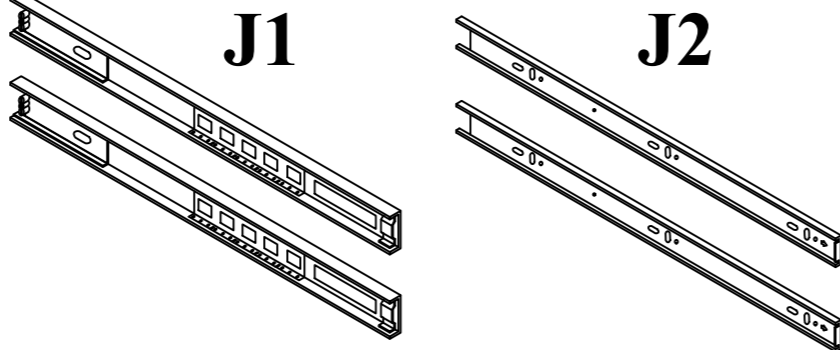
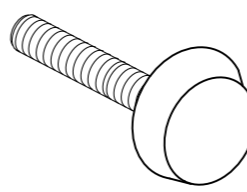
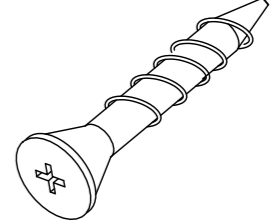
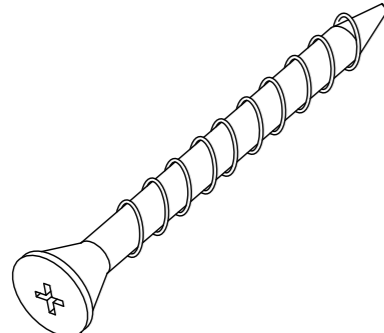
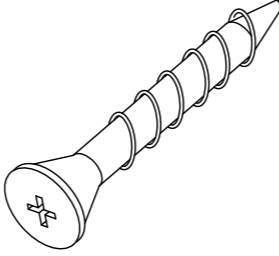
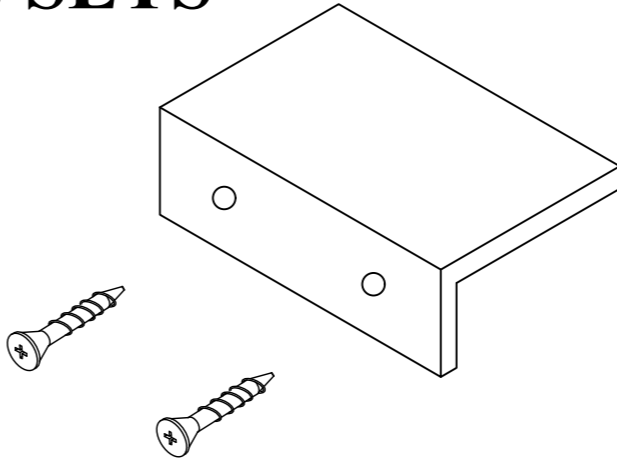
<b>A</b> 6PCS  <b>Double End Bolt</b>	<b>B</b> 18PCS  <b>Minifix</b>	<b>C</b> 30PCS  <b>Minifix Cap</b>	<b>D</b> 38PCS  <b>Wood Dowel M8x30MM</b>
<b>E</b> 2SETS  <b>Cam Lock</b>	<b>F</b> 8PCS  <b>2" Hinges</b>	<b>G</b> 2SETS  <b>Handle with Screw 20mm</b>	<b>H</b> 12PCS  <b>Caster</b>
<b>I</b> 2SETS  <b>Full Extension Drawer Slide 16"</b>	<b>J</b> 2SETS  <b>Full Extension Drawer Slide 14"</b>	<b>K</b> 4PCS  <b>Adjustor</b>	<b>L</b> 140PCS  <b>Screw M3.5 x 16MM</b>
<b>M</b> 27PCS  <b>Screw M4 x 32MM</b>	<b>N</b> 24PCS  <b>Screw M4 x 20MM</b>	<b>O</b> 2 SETS  <b>Handle with Screw M3 x 12mm</b>	

### HARDWARE LIST (BOX 2)

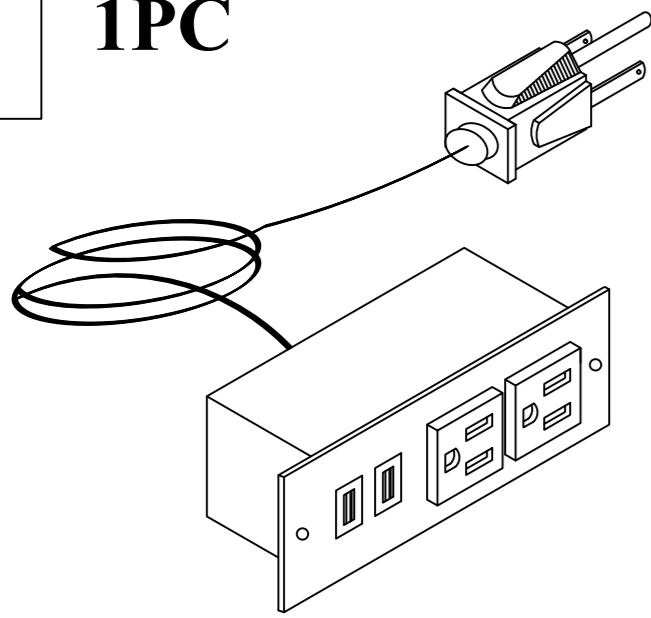
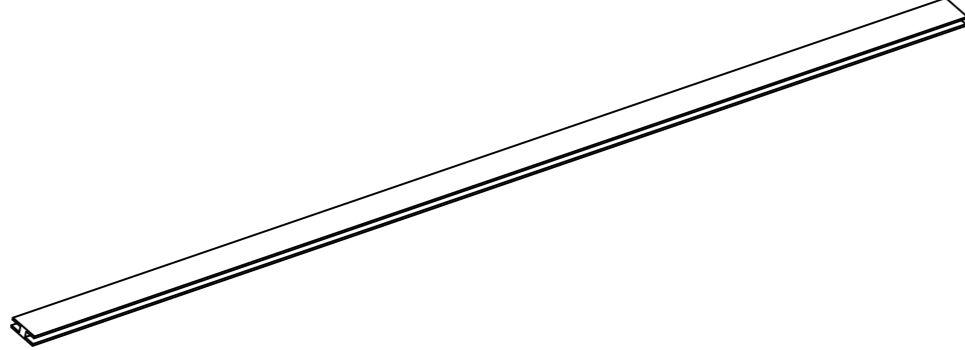
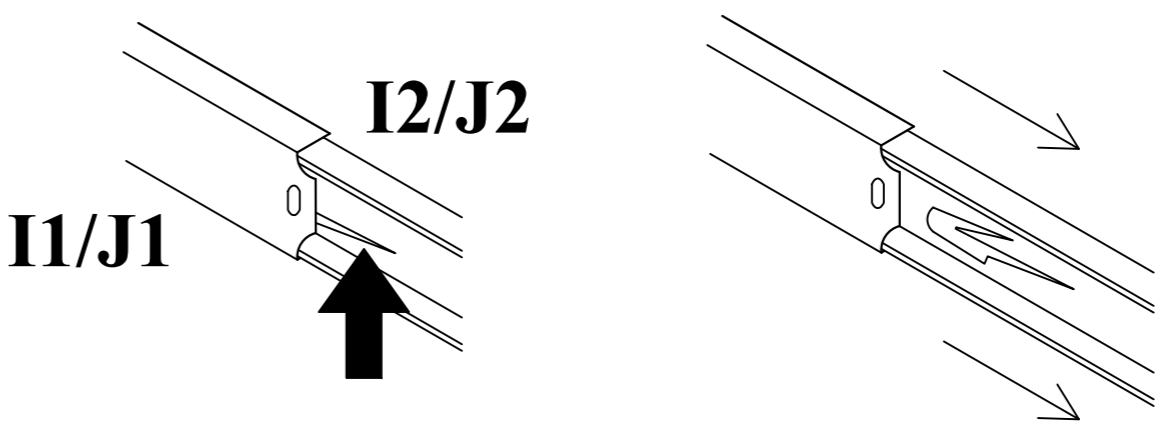
<b>O</b> 1PC  <b>USB Port</b>	<b>P</b> 1PC  <b>H - Connector 1418MM</b>	 <b>Disconnect Levers</b> Drawer Slides arrived connected (I1 to I2 and J1 to J2). To disconnect the slides for assembly, pull out the slides and find the plastic lever (white color) on I2/J2, push upward with finger and gently pull out the slide
--	---	---

TOOLS REQUIRED (Provided)

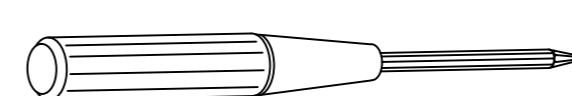

Screwdriver

**Step 1**

Attach Minifix (B), Dowel (D) and Adjustor (K) to Side Panel (1,6) accordingly.

Attach Drawer Slide 16" (I1) with screw (L).

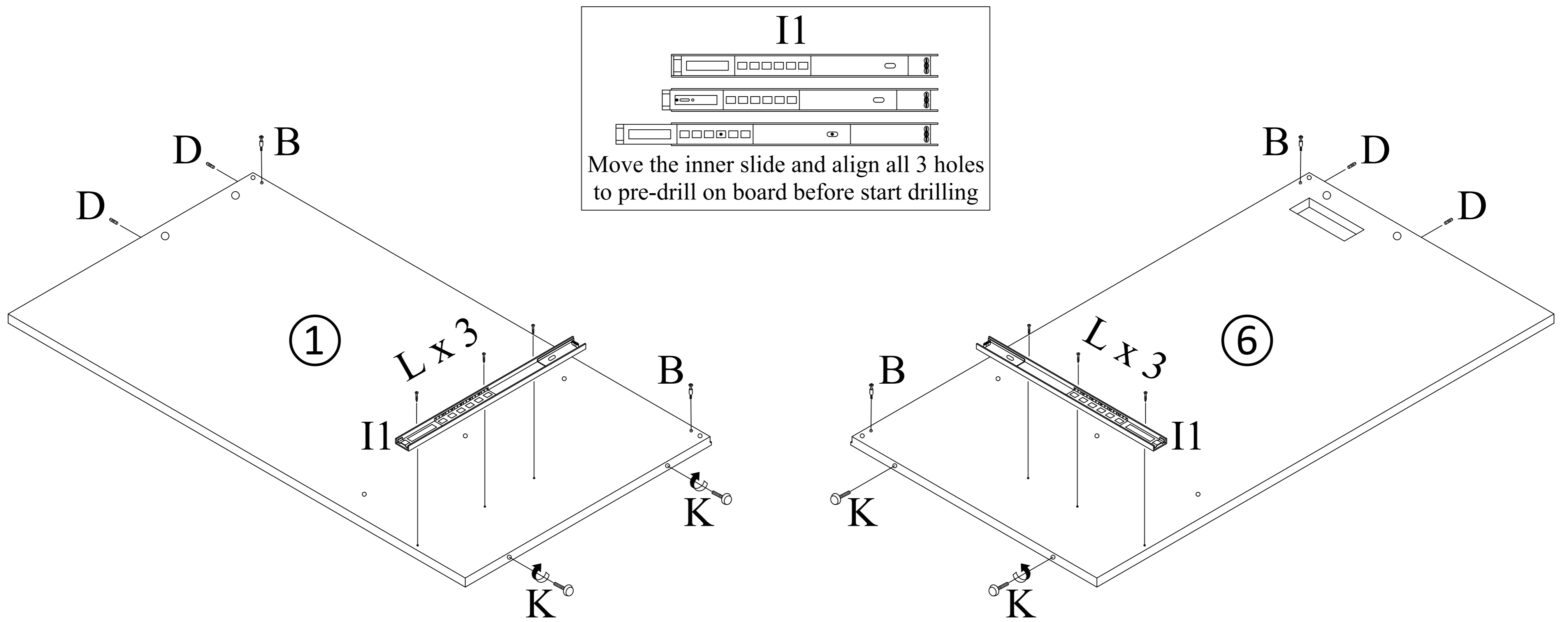

Attach Dowel (D) to Parts(2,3,4,10,12,14) accordingly.

Attach Minifix (B) to Top Panel (7).

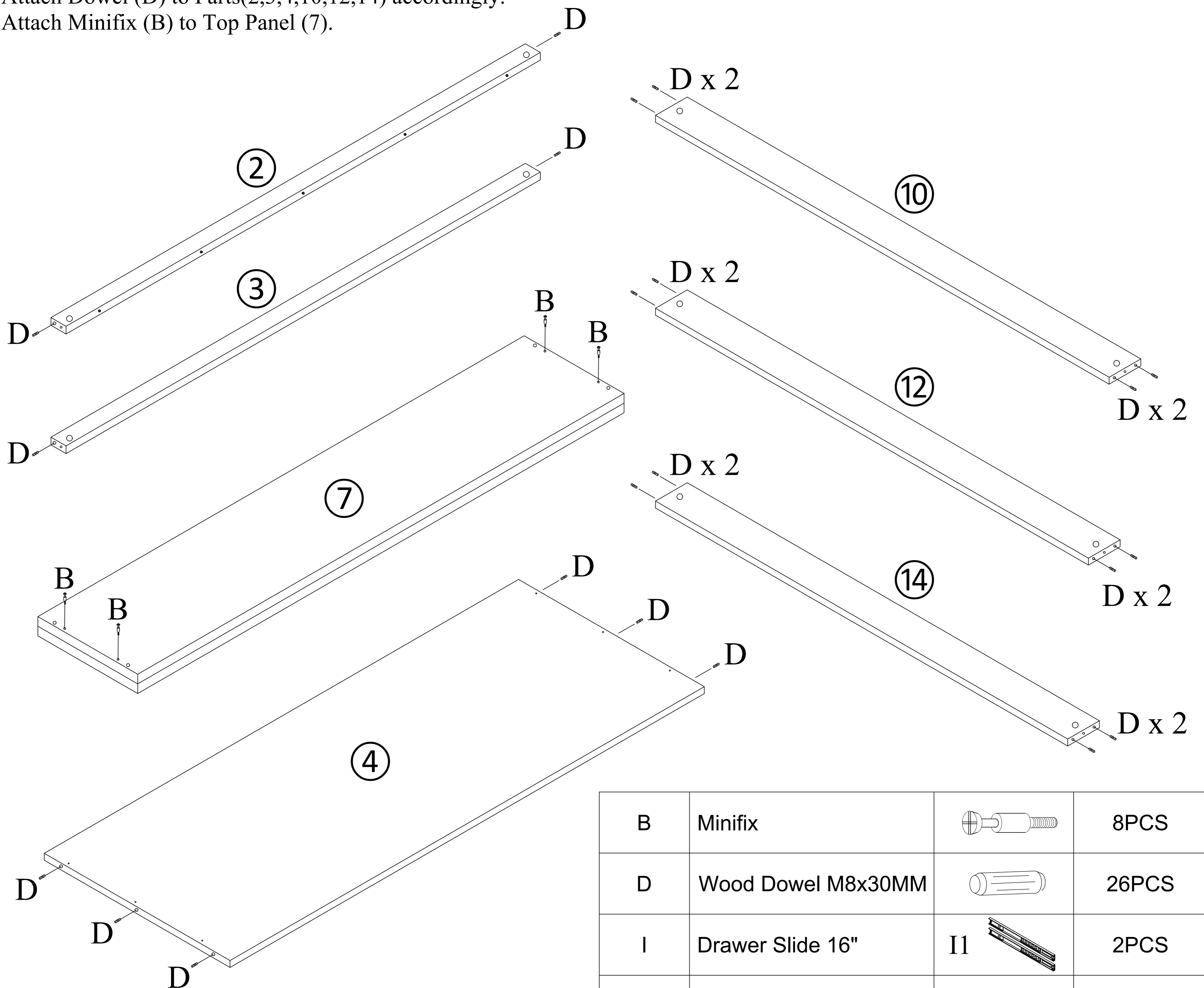

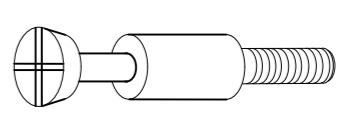
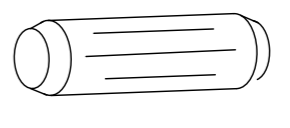
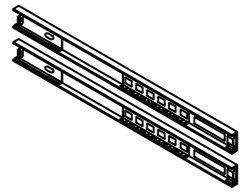
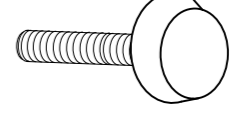
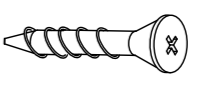
B	Minifix		8PCS
D	Wood Dowel M8x30MM		26PCS
I	Drawer Slide 16"	I1 	2PCS
K	Adjustor		4PCS
L	Screw M3.5 x 16MM		6PCS

Attach Minifix (B) onto parts (9,11,13). Attach Drawer Slides (I,J) and Caster (H) onto Parts (9,11,13,15) accordingly using screw (L, N).

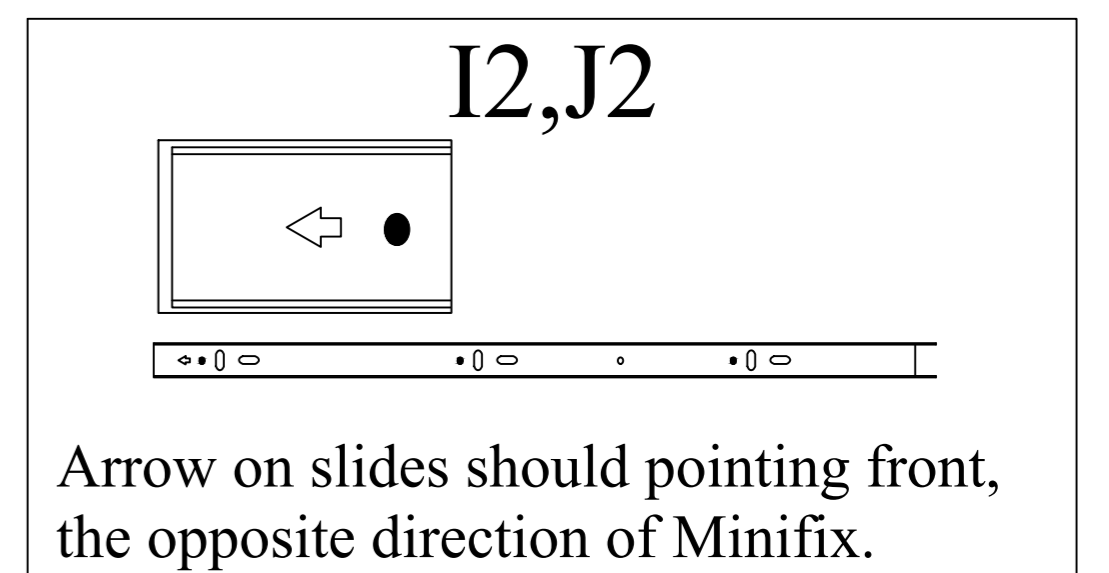
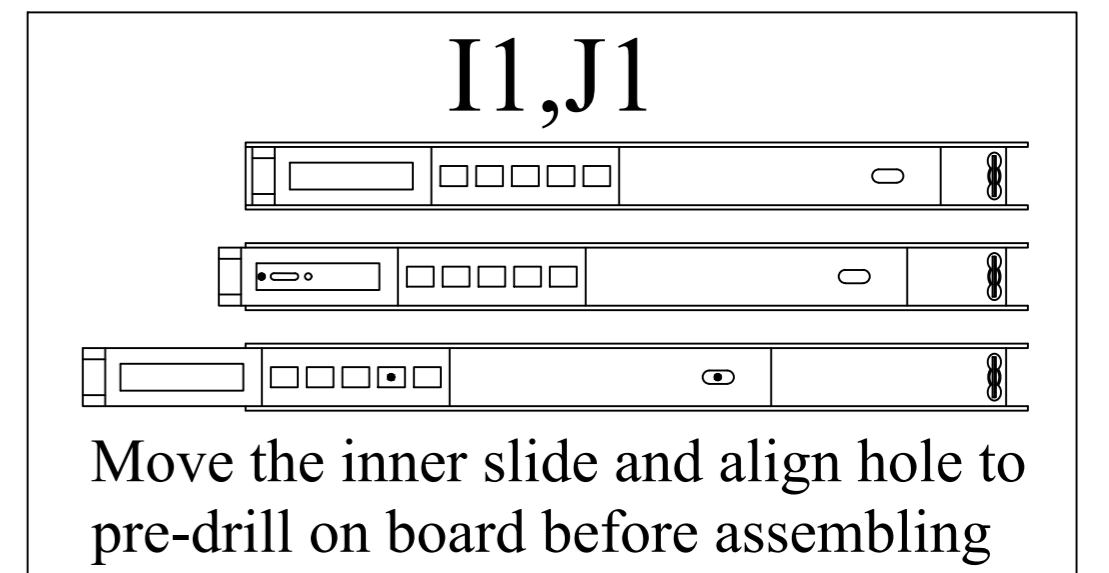
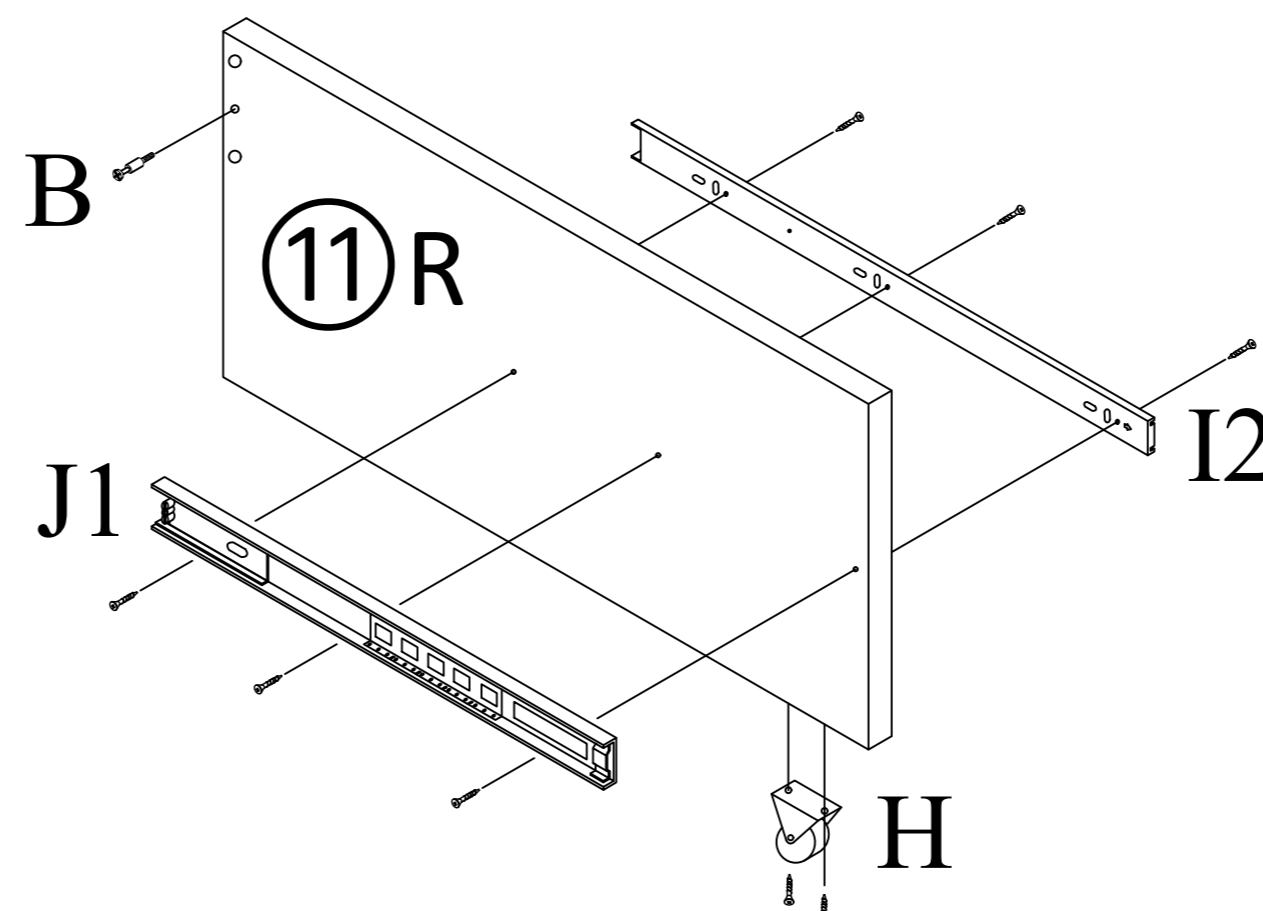
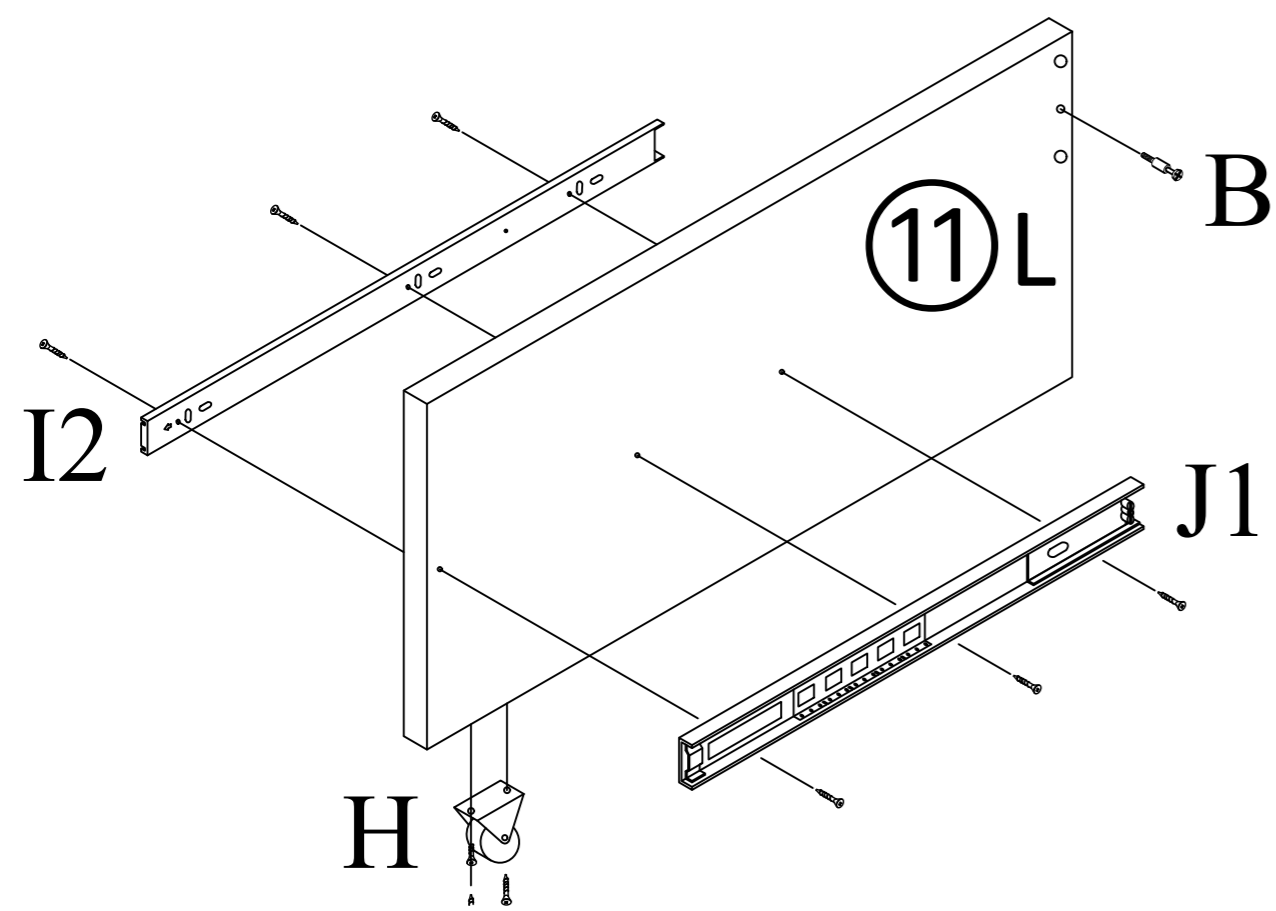
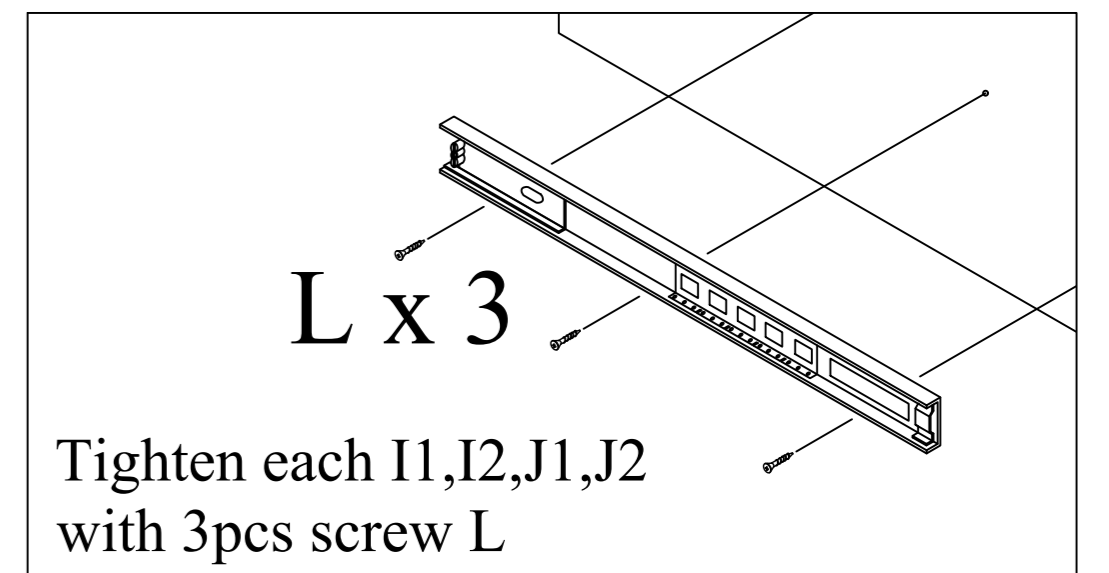
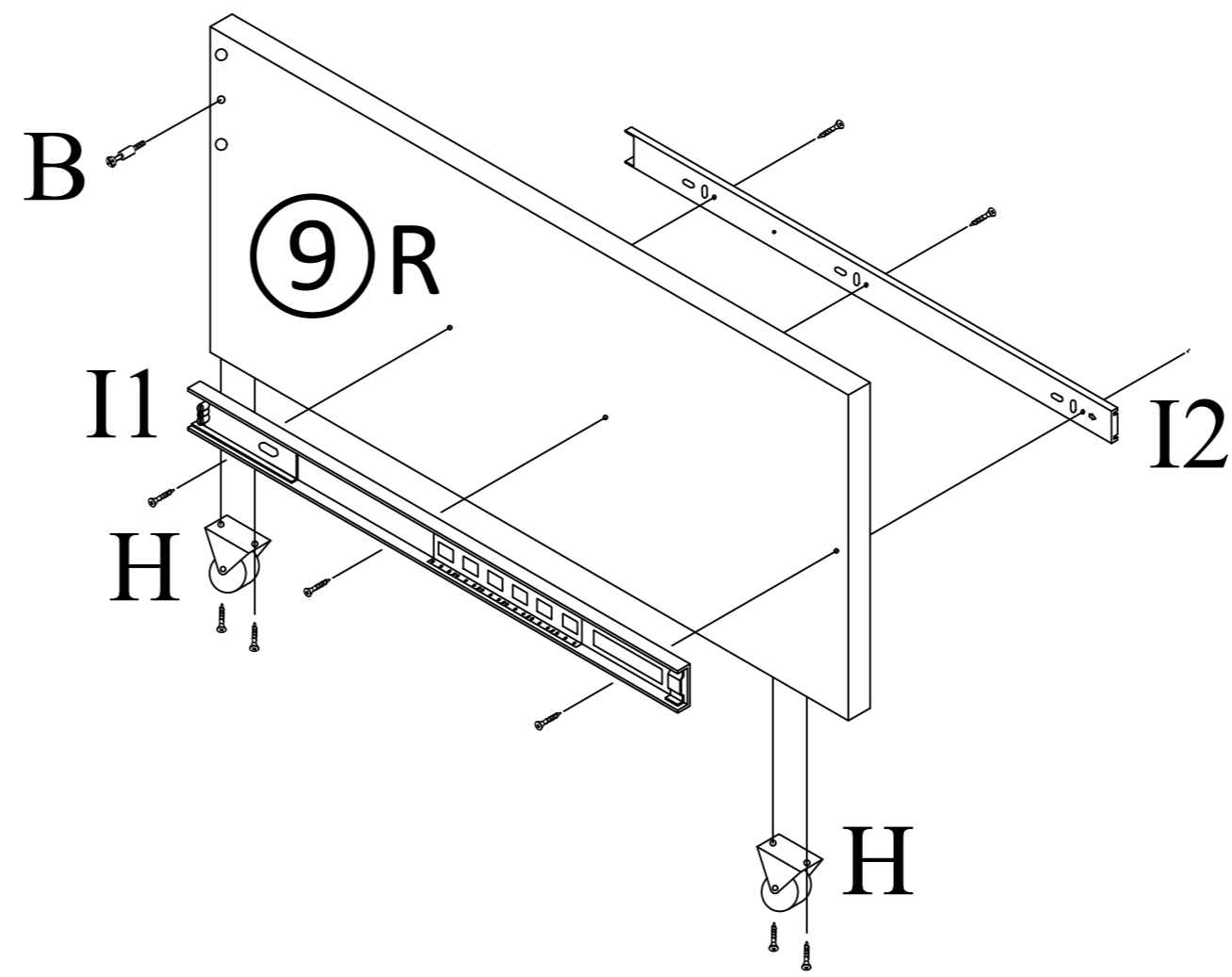
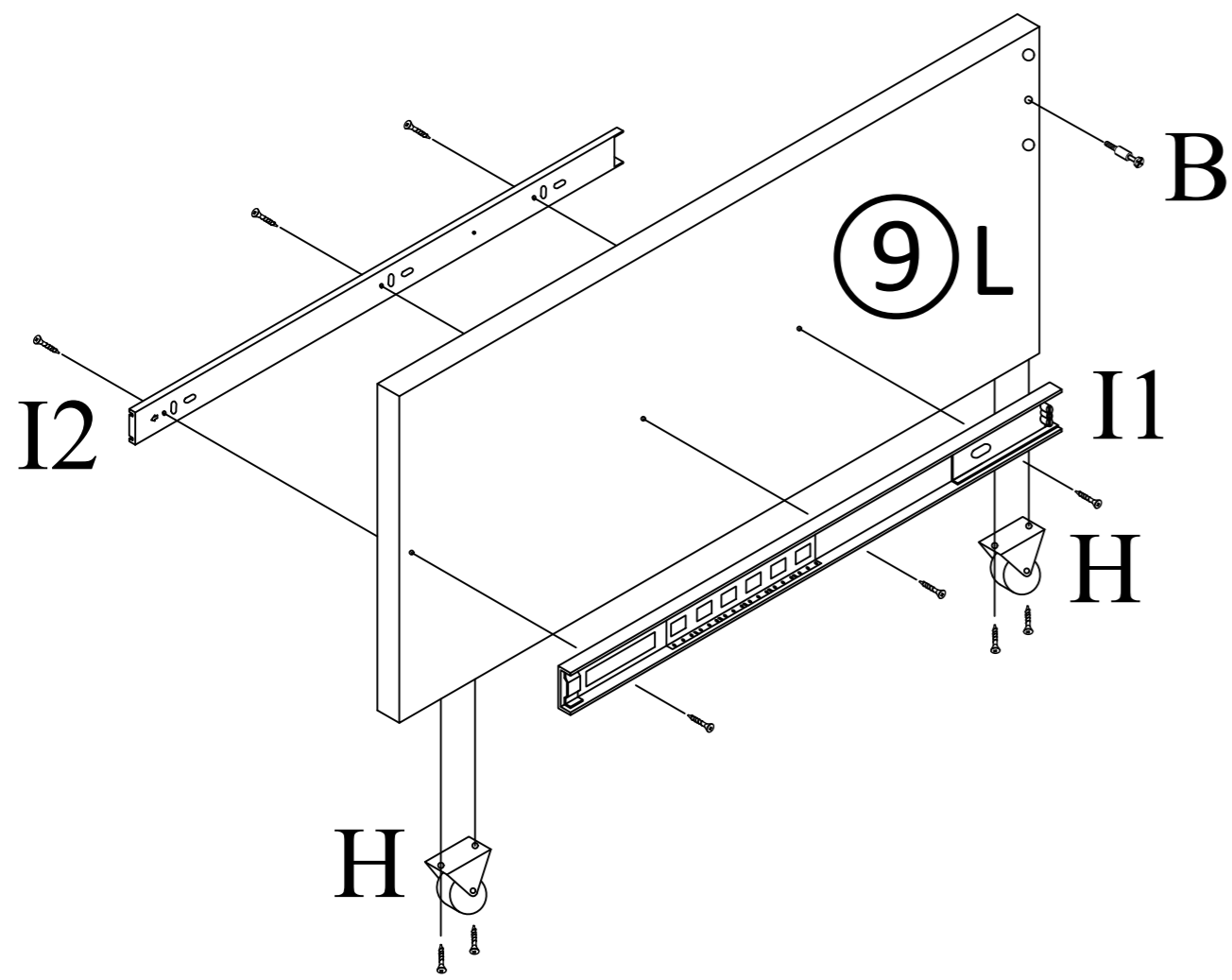

Apply the correct slides on parts as shown. Failing to follow will cause damages to parts and not able to finish the assembly later.

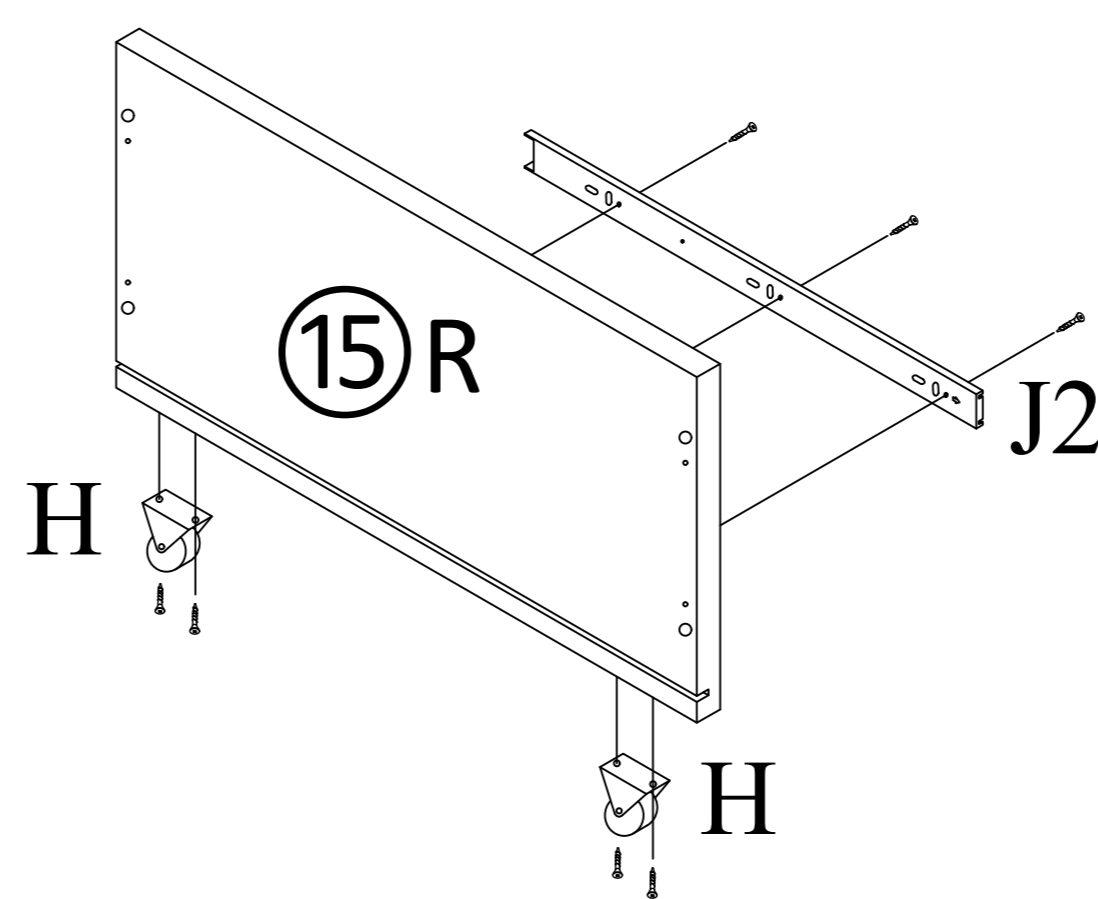
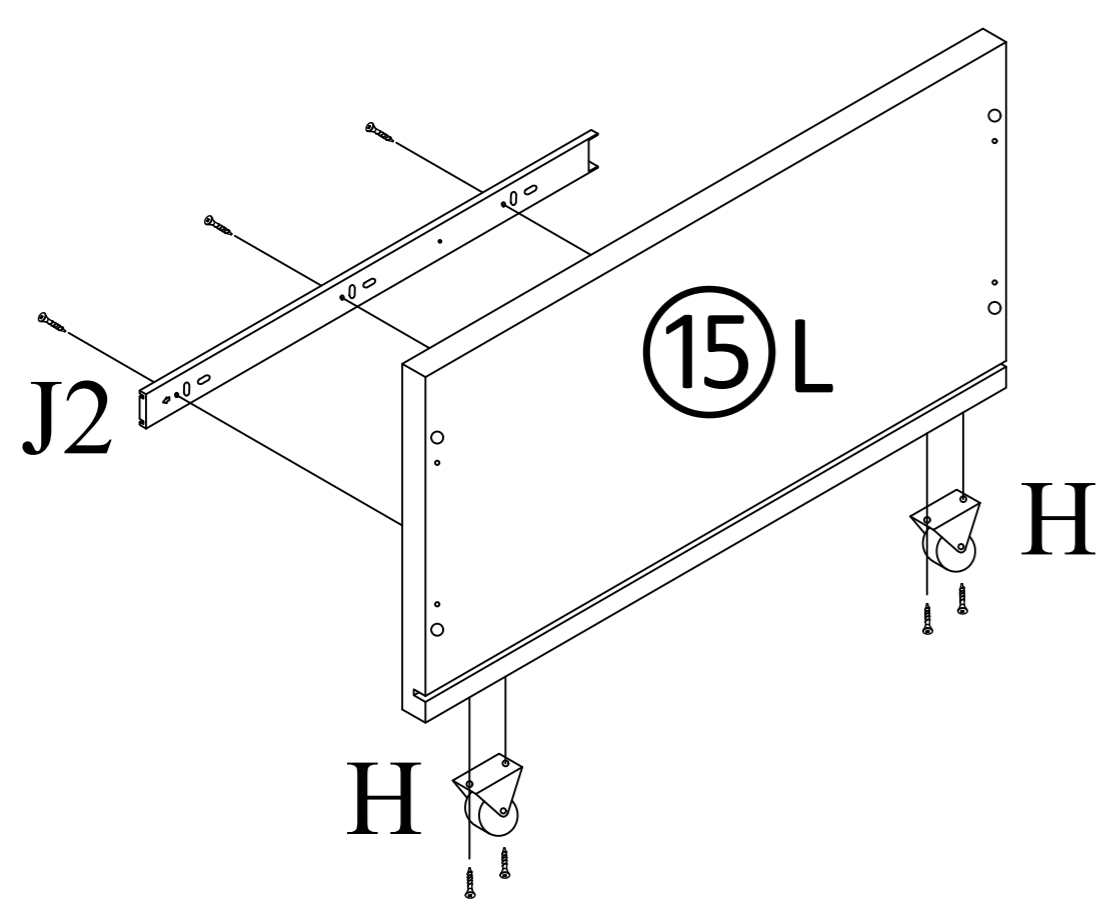
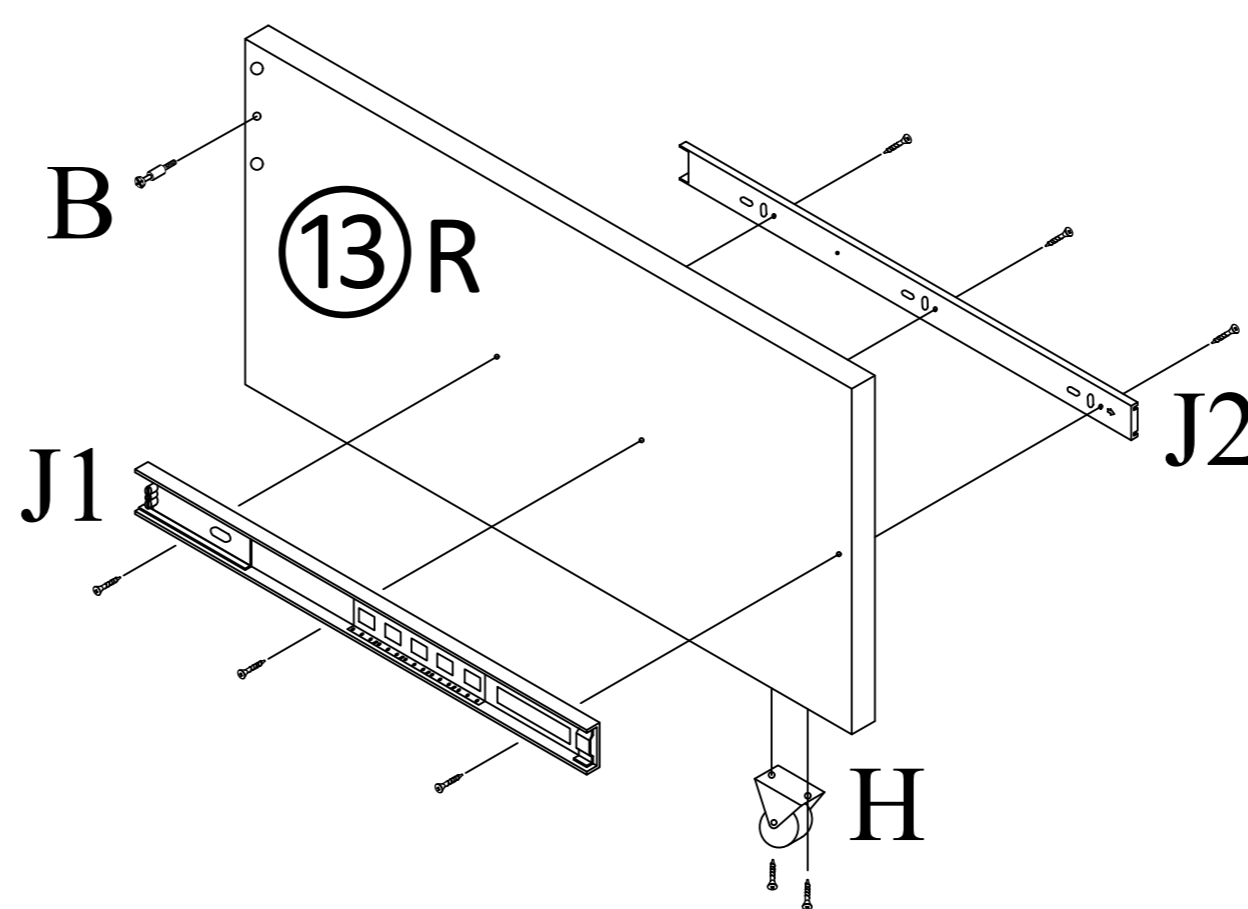
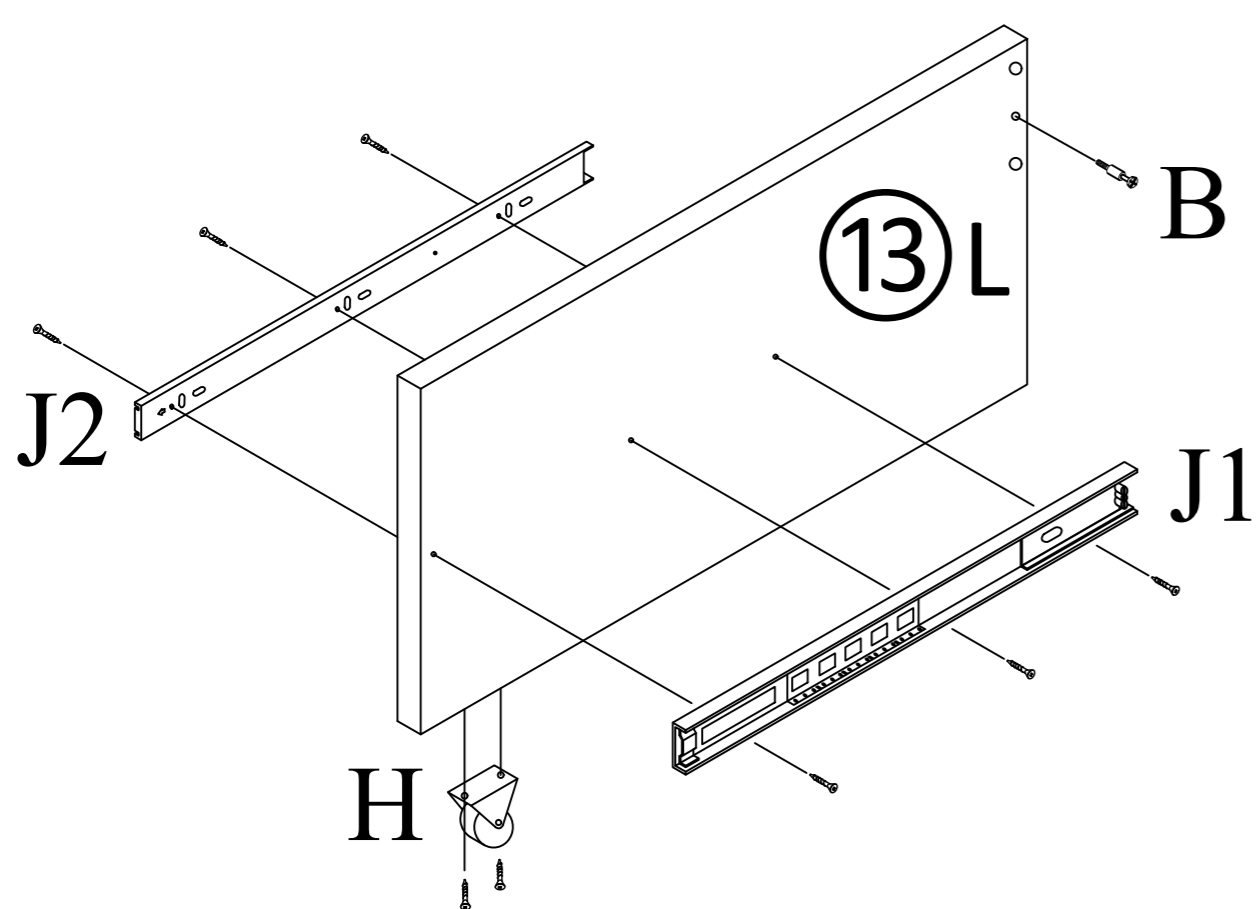
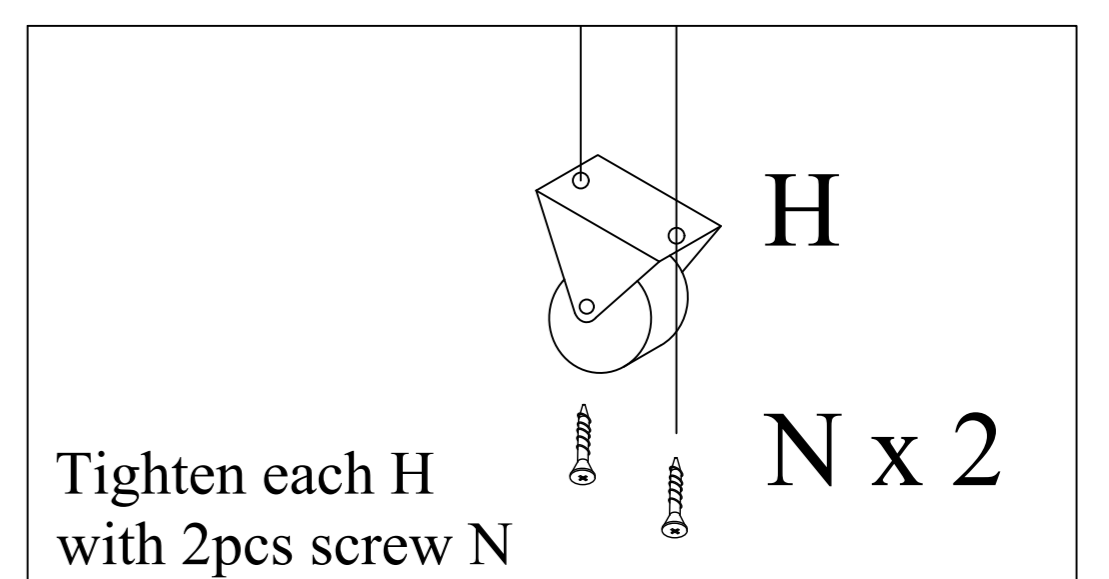

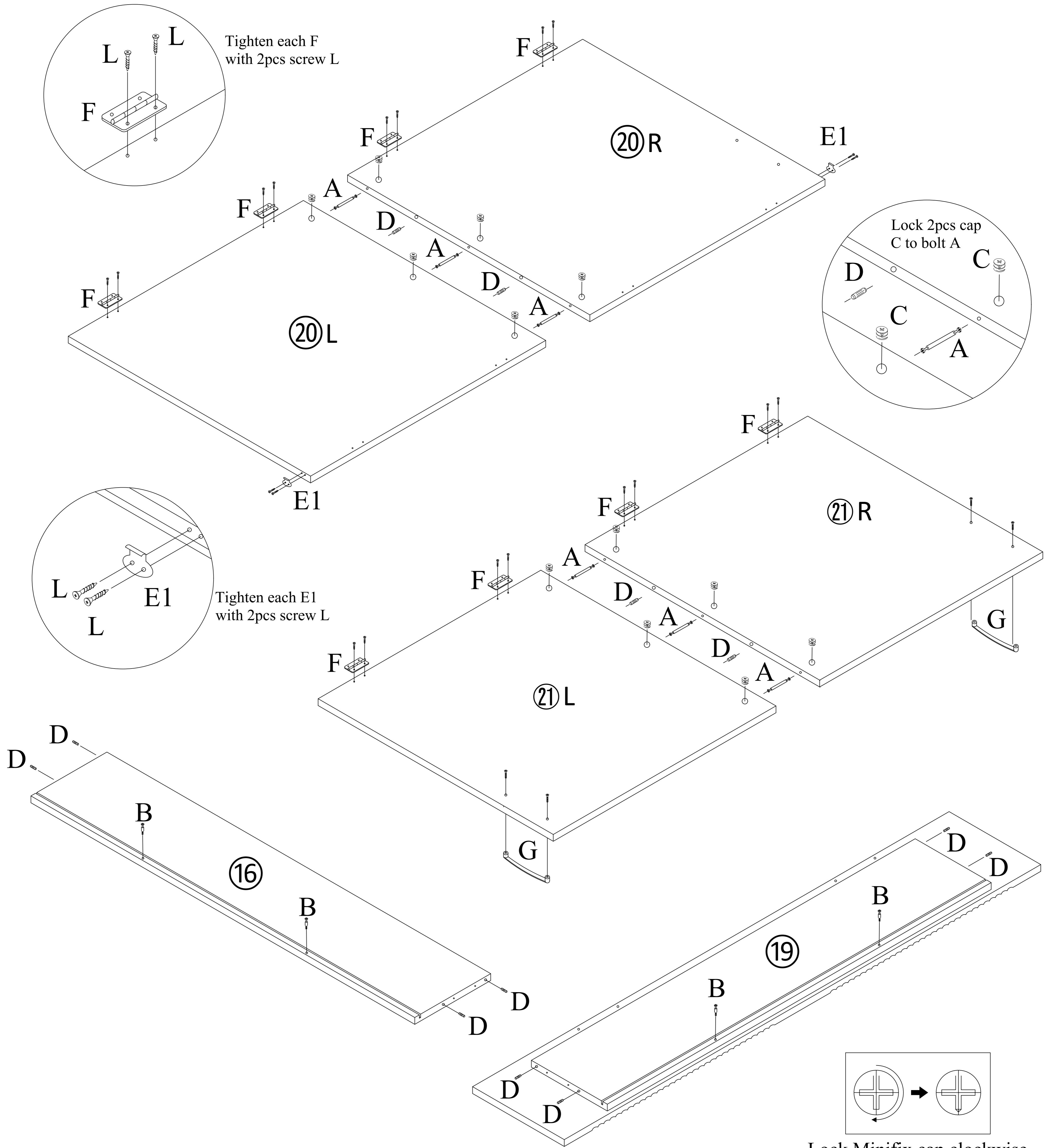

B	Minifix		6PCS	J	Drawer Slide 14"		2SETS
H	Caster		12PCS	L	Screw M3.5 x 16MM		42PCS
I	Drawer Slide 16"		2SETS	N	Screw M4 x 20MM		24PCS

Attach Minifix (B) and Dowel (D) to Parts (16,19) accordingly.  
 Attach Cam Lock (E1) to Doors (20,21) using screw (L).  
 Attach Hinges (F) to Parts (20,21) using screw (L). Attach Handle (G) to Parts (20,21).  
 Connect 20L to 20R and 21L to 21R with Dowel (D) and Bolt (A), and lock with Cap (C).

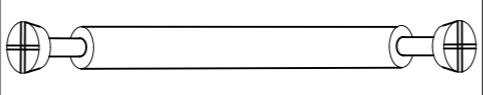
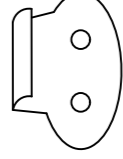
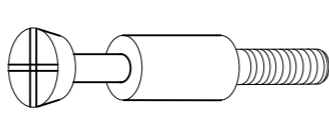
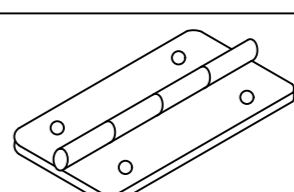

Lock Minifix cap clockwise

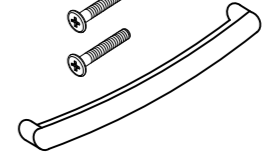
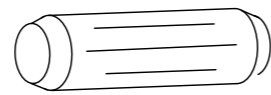
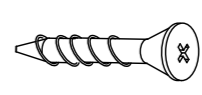
A	Double End Bolt		6PCS	E	Cam Lock	E1 	2PCS
B	Minifix		4PCS	F	2" Hinges		8PCS
C	Minifix Cap		12PCS	G	Handle with Screw		2SETS
D	Wood Dowel M8x30MM		12PCS	L	Screw M3.5 x 16MM		20PCS

Step 2 : Attach Connection Rail (5) to Bottom Panel (4) using screw (M).

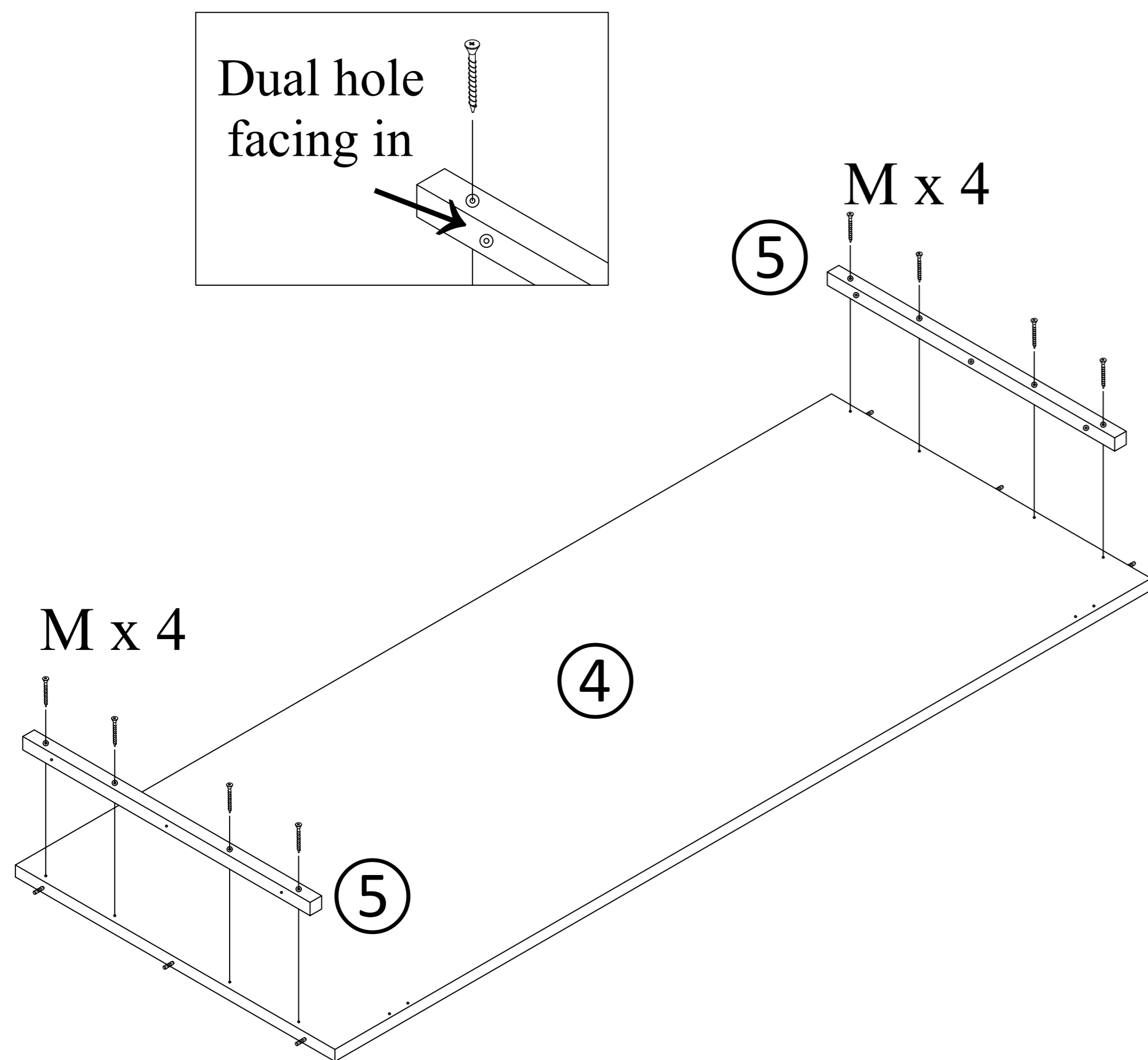

Step 3 : Attach Rails (2,3) onto Left Panel (1) and lock with Cap (C).

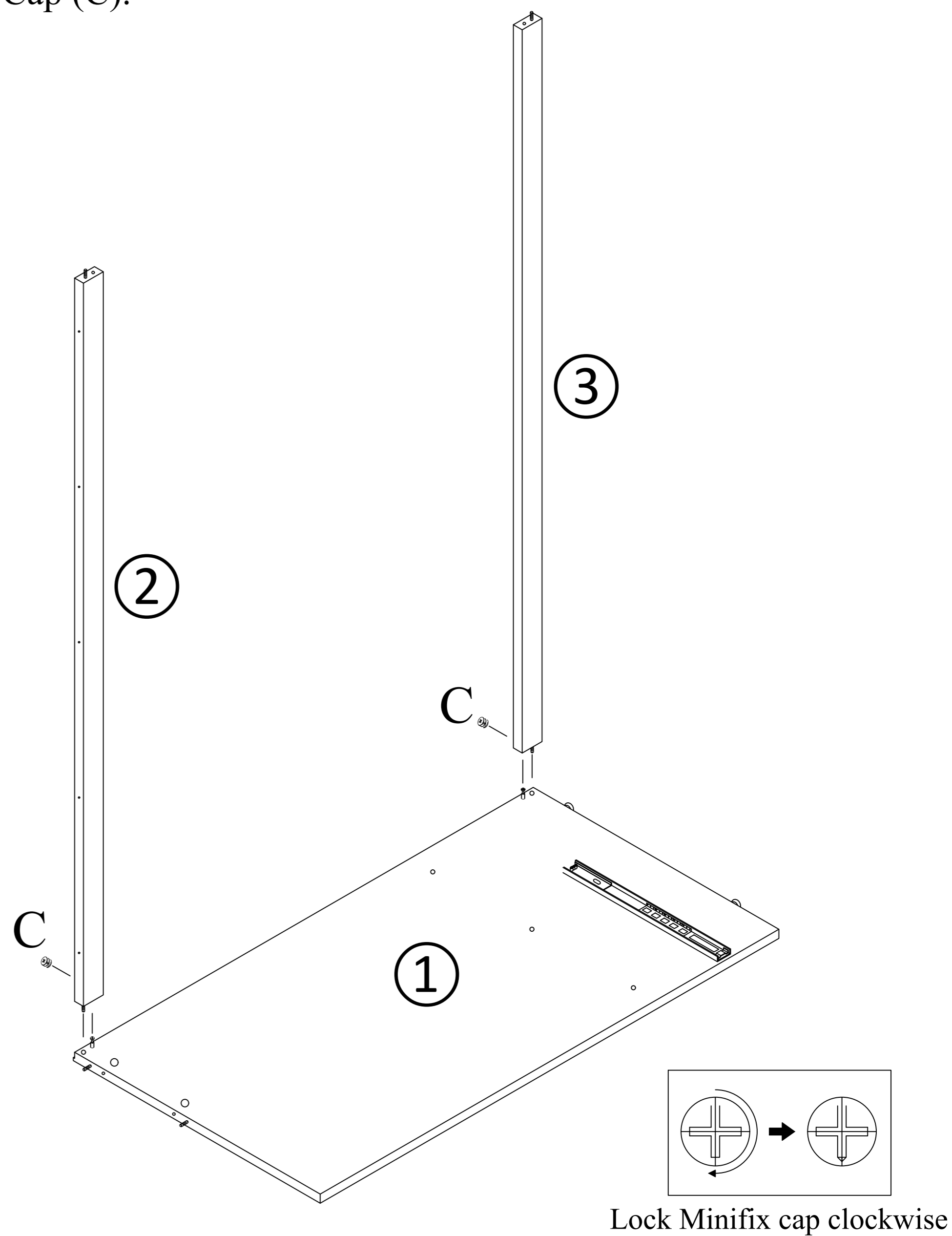

M Screw M4 x 32MM

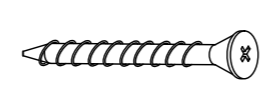

8PCS

C Minifix Cap

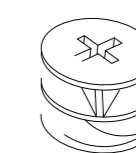

2PCS

Step 4 : Attach Bottom Panel (4,5) with screw (M).

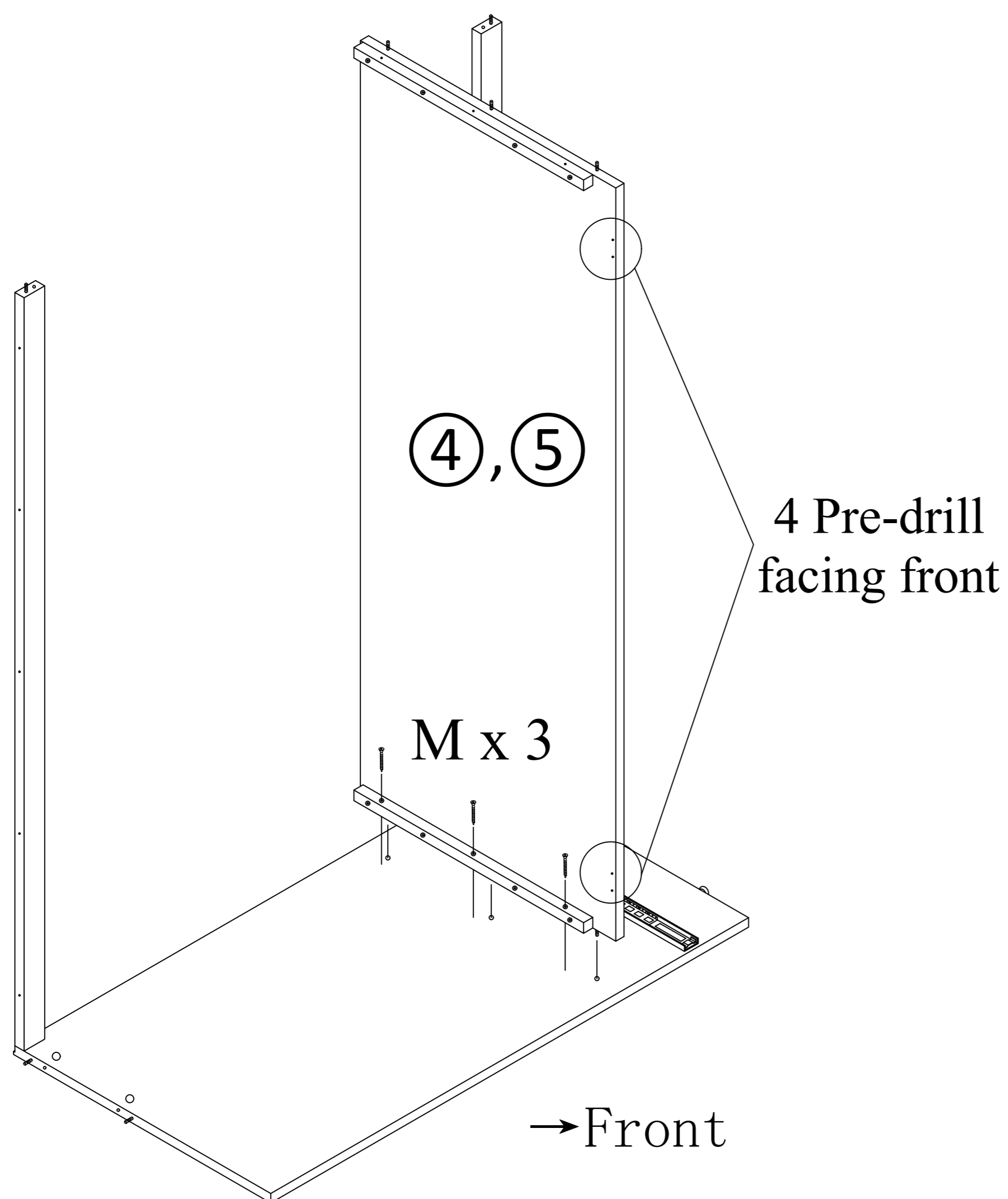

Step 5 : Attach Right Panel (6) and lock Cap (C). Tighten the connection with screw (M).

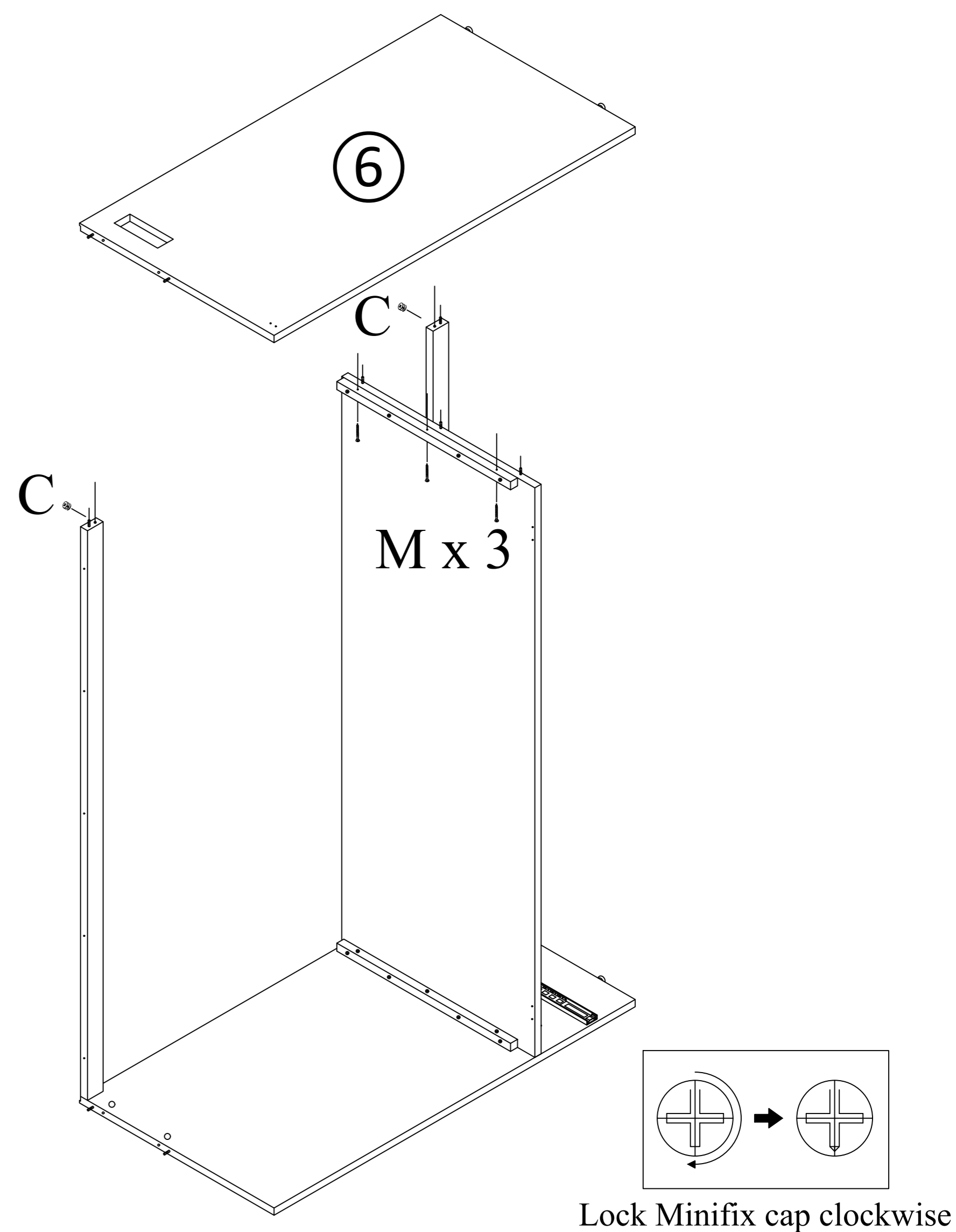

M Screw M4 x 32MM

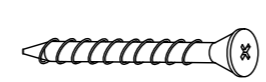

3PCS

C Minifix Cap



2PCS

M Screw M4 x 32MM



3PCS

Step 6 : Turn the assembled parts up. Attach Top Panel (7) and lock Cap (C), tighten the connection with screw (M). Slot the USB port (O) through Right Panel (6) and lock with screw (L). Attach Locker (E1) to Side Panel (1,6) with screw (L).

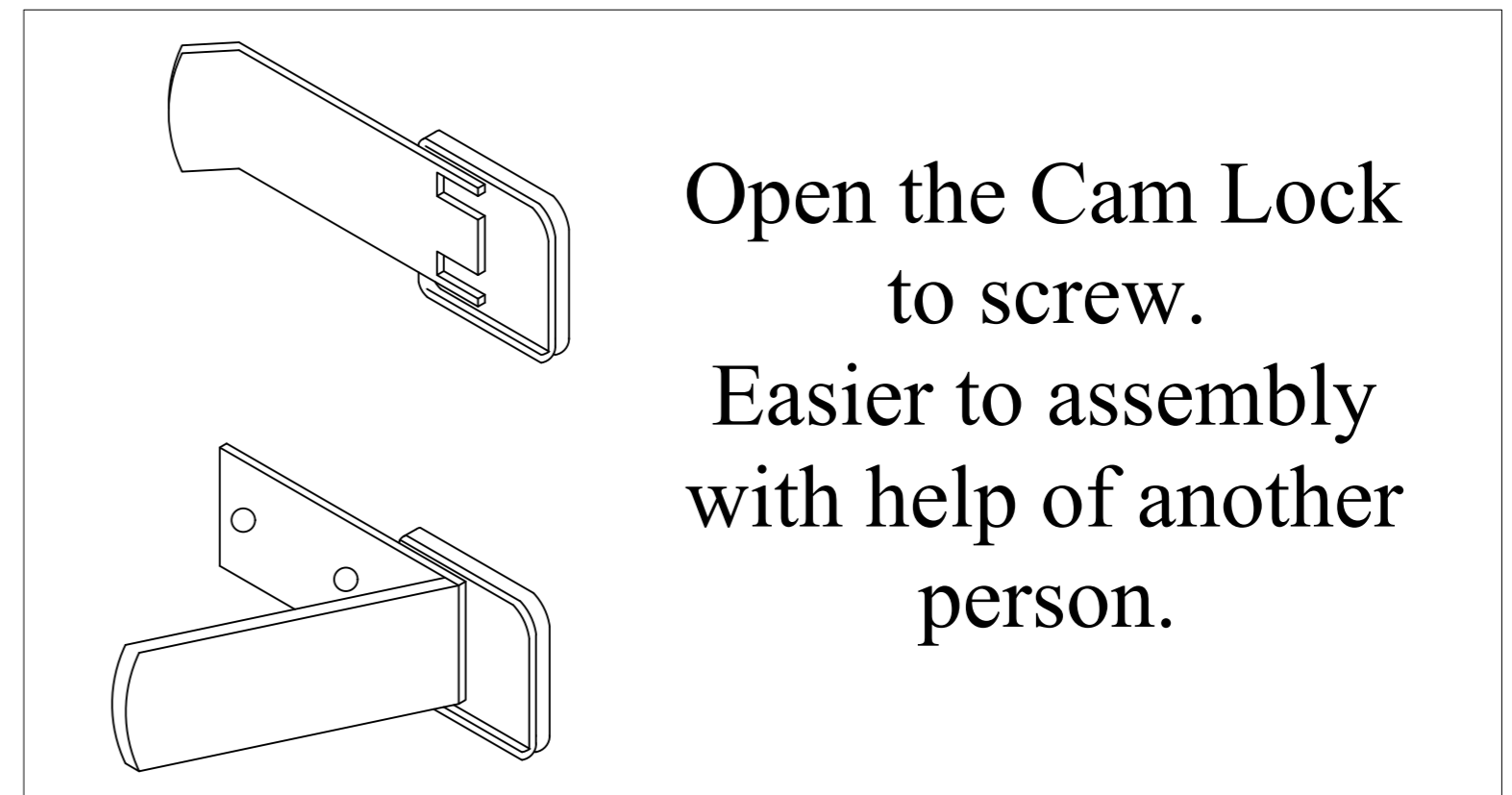
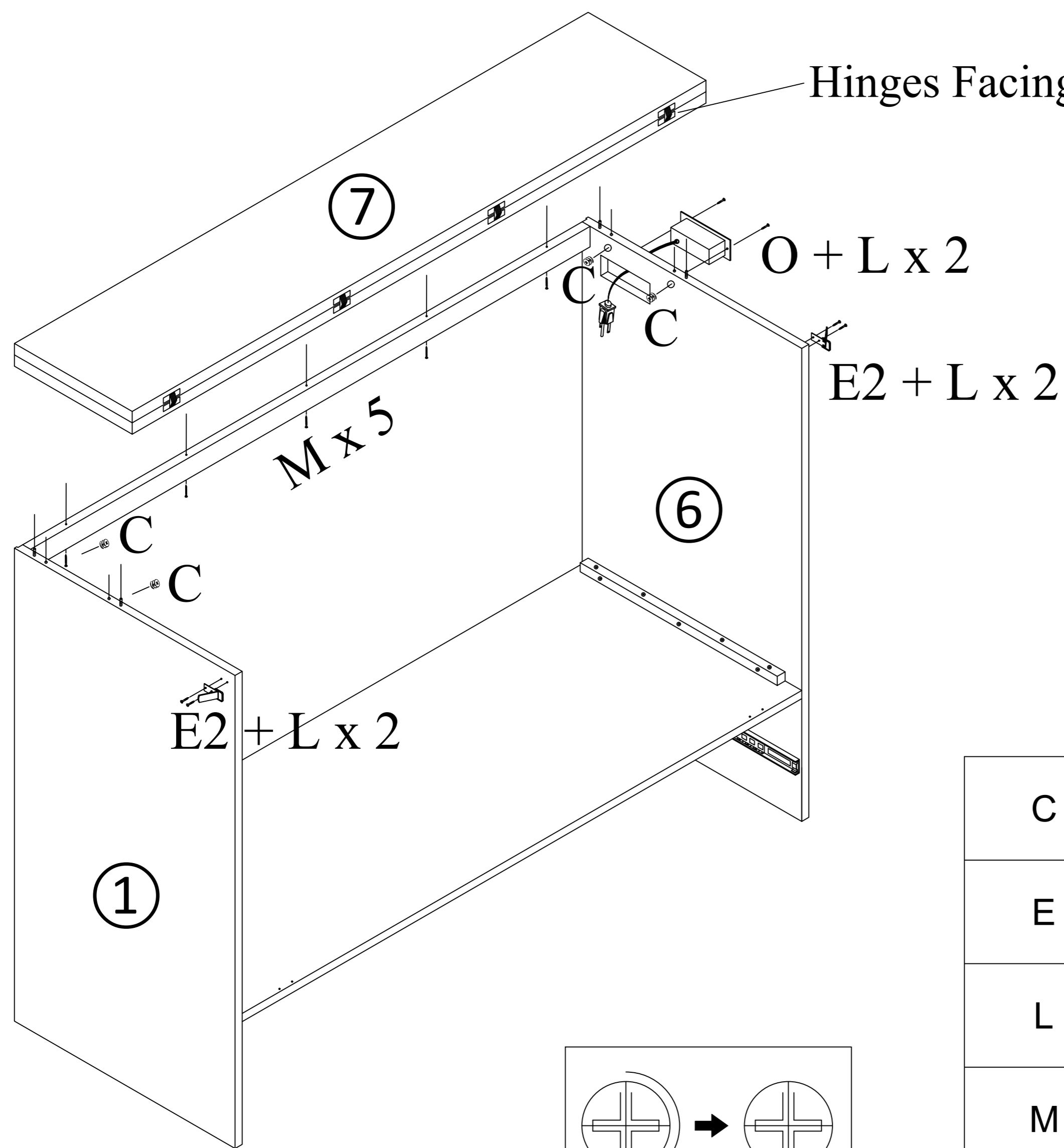

C	Minifix Cap		4PCS
E	Locker	E2	2PCS
L	Screw M3.5 x 16MM		6PCS
M	Screw M4 x 32MM		5PCS
O	USB Port		1PC

Lock Minifix cap clockwise

Step 7 : Connect Extension Back 1 (10) to Extension Sides 1 (9) and lock with Cap (C).

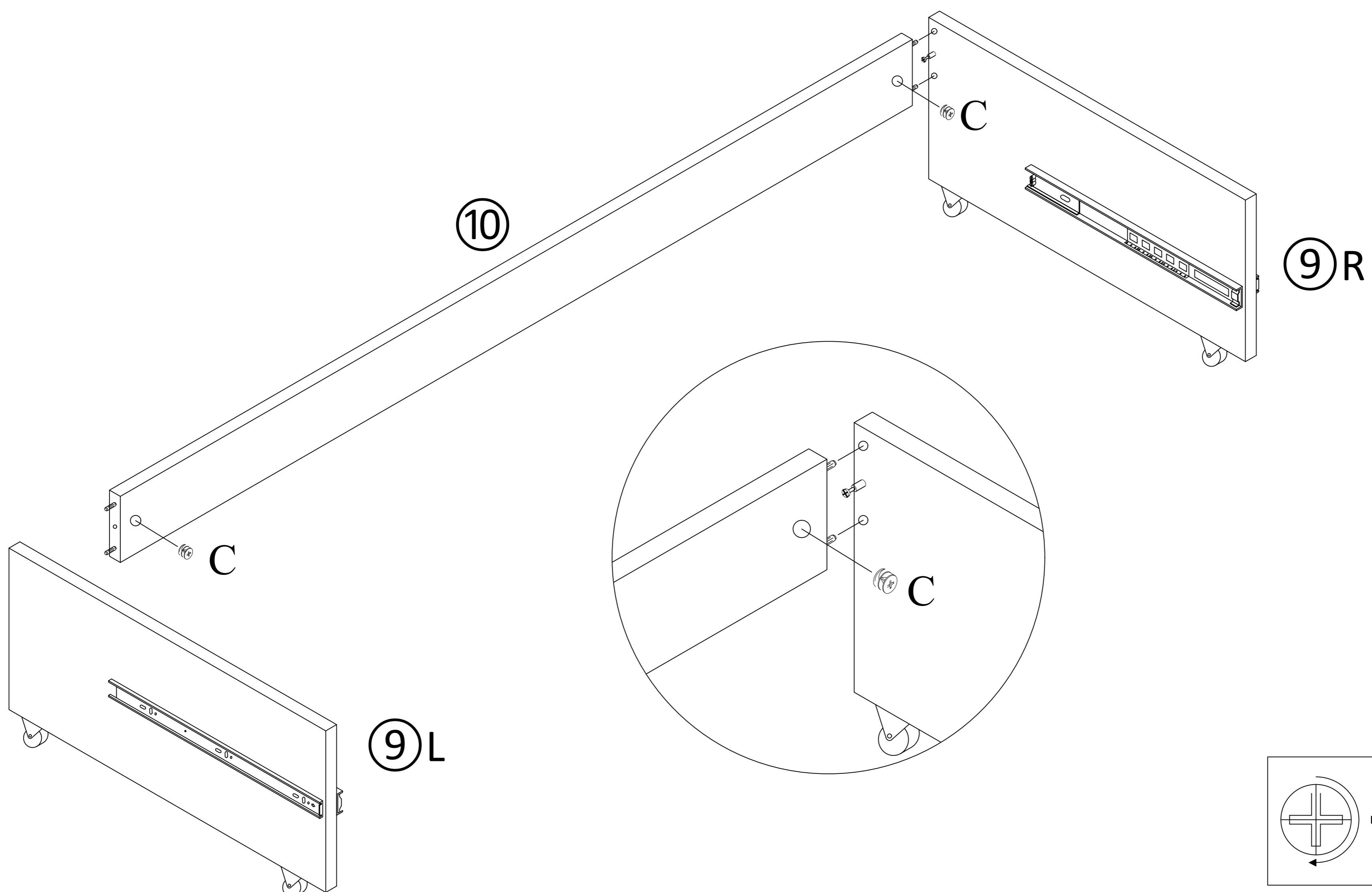

Lock Minifix cap clockwise

C	Minifix Cap		2PCS
---	-------------	--	------

Step 8 : Slot Back Panels (8) into H-Connector (P) and attach it with screw (L). Slot Extension 1 (9L,9R,10) to Side Panel (1,6).

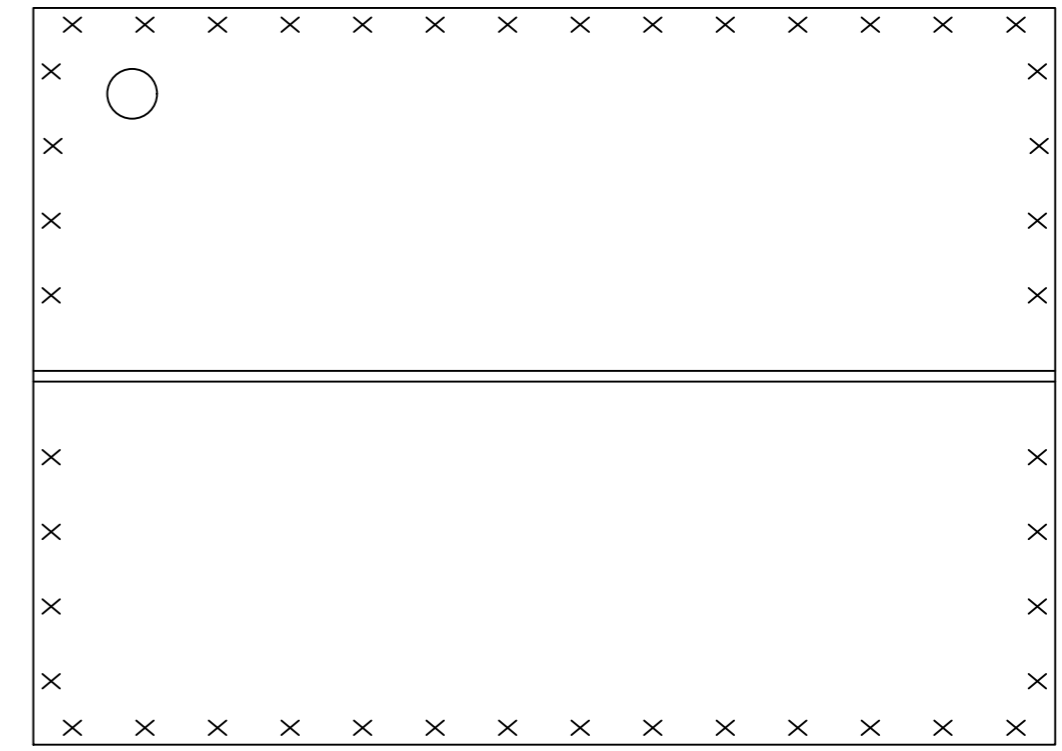
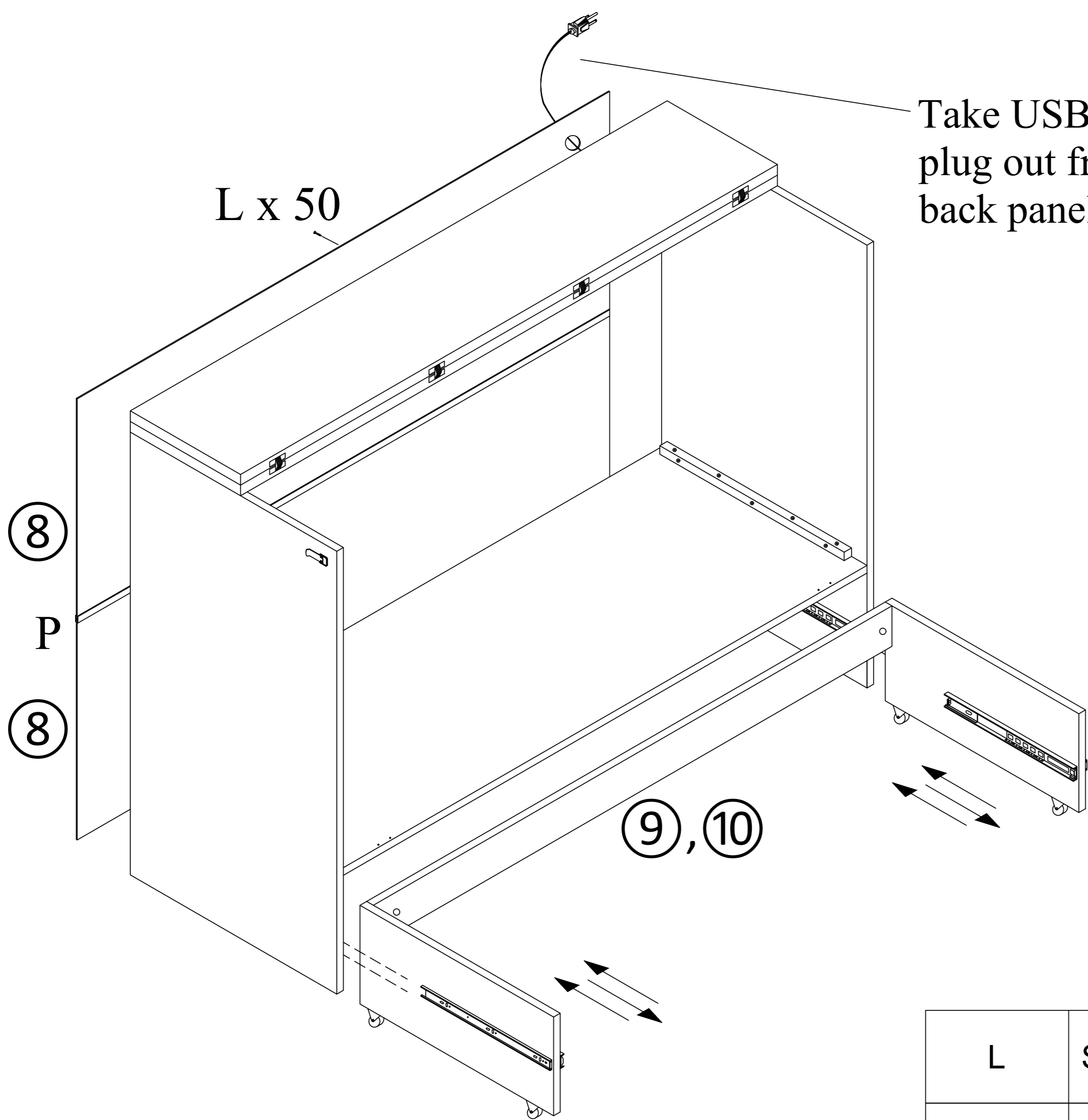

Screw Array Guidance.  
(Back View)

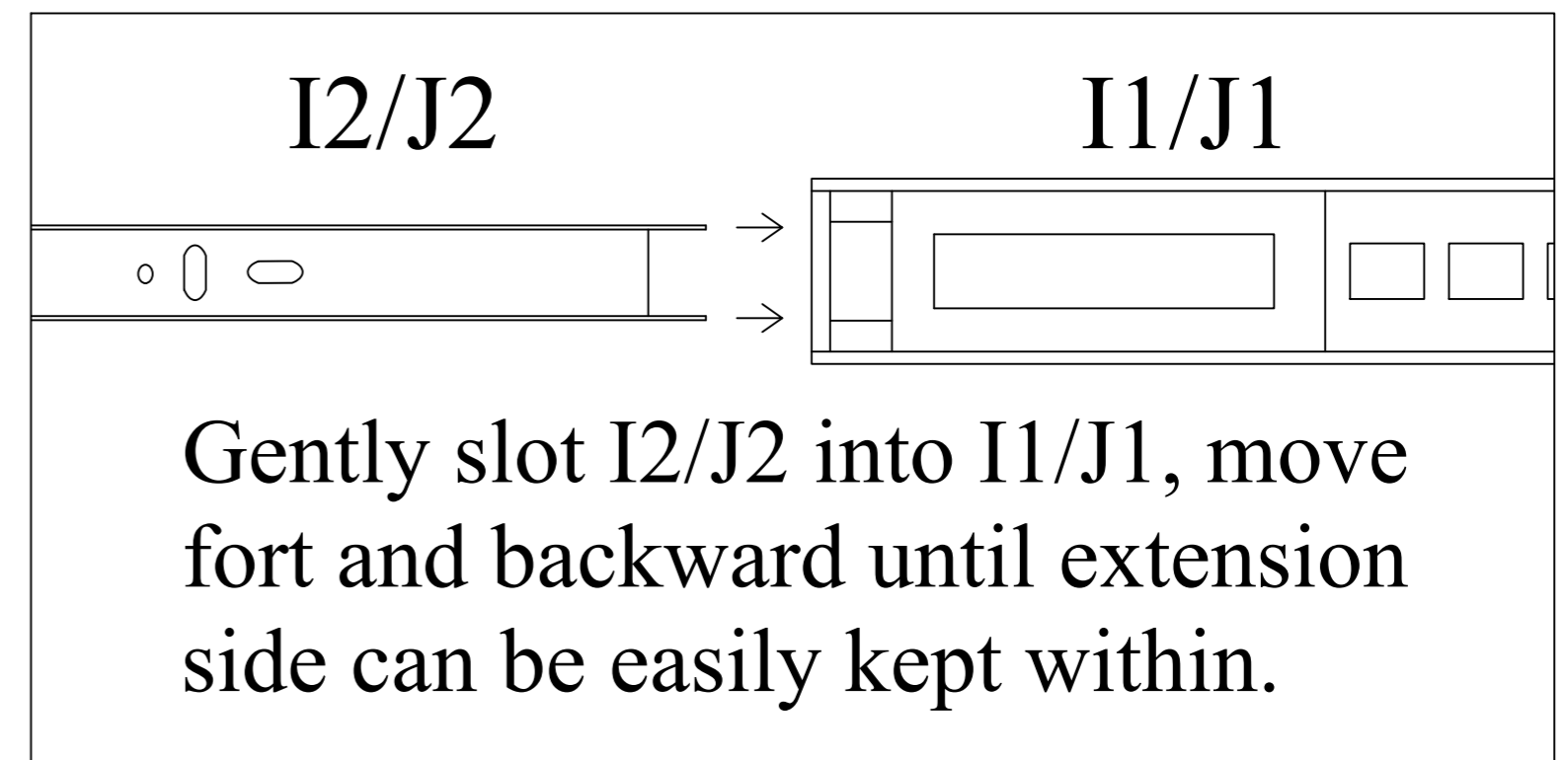

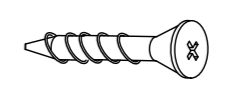
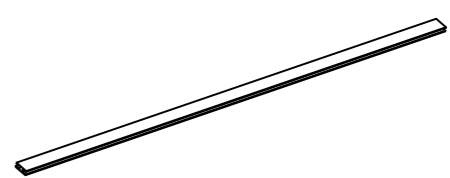
L	Screw M3.5 x 16MM		50PCS
P	H - Connector		1PC

Step 9 : Attach Extension Side 2 (11) as earlier. Put Extension Back 2 (12) in between sides (11). Use Dowel and Minifix installed earlier to position one side first. The other side can be slotted in easier when extension side (11) is moved outward with small force. Lock Cap (C) after slotted in.

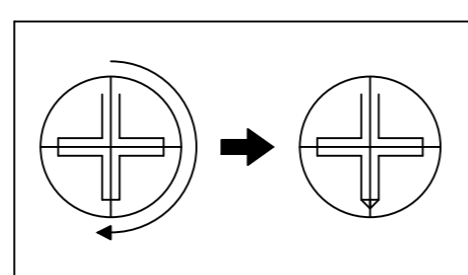
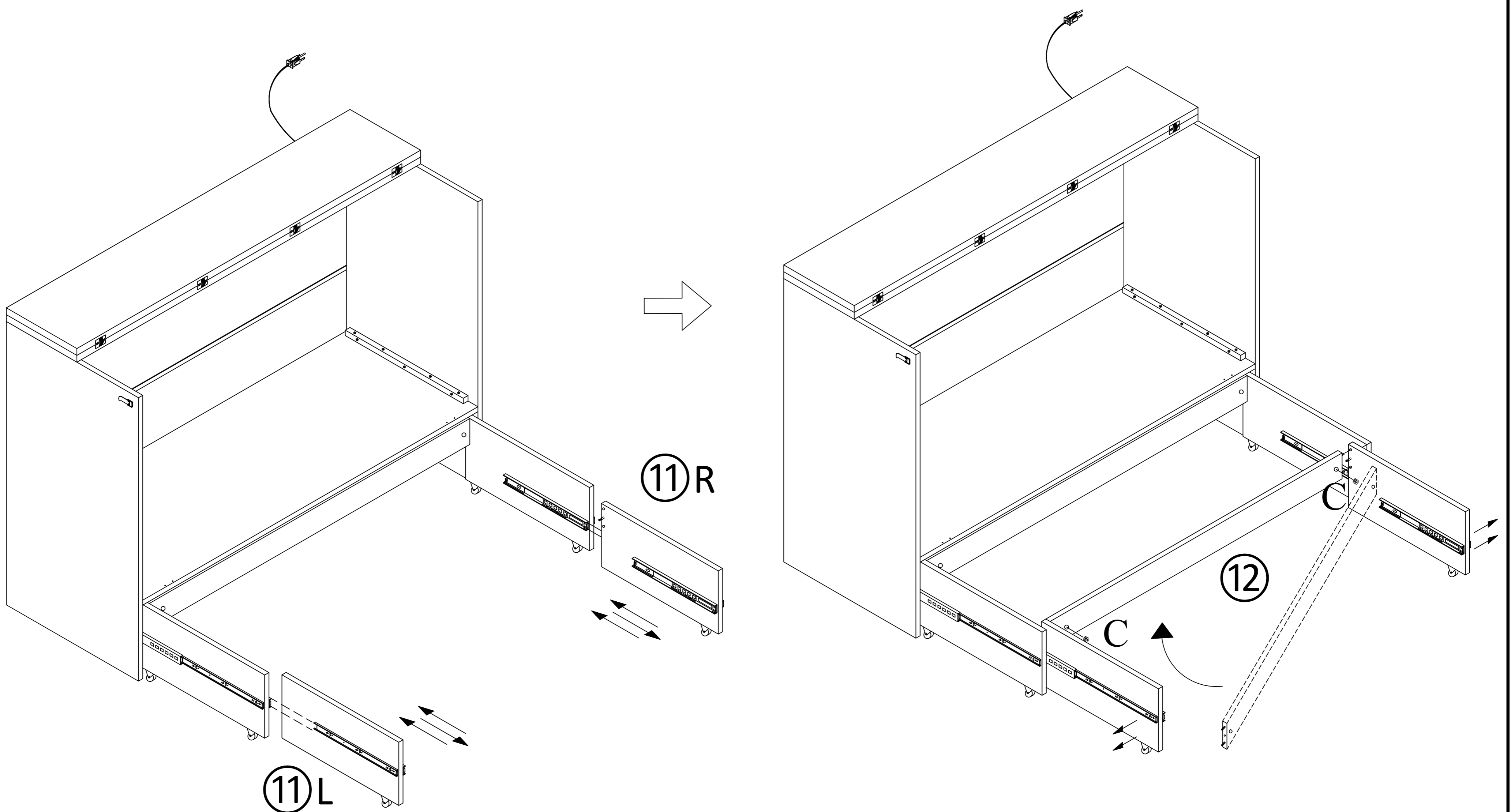

Lock Minifix cap clockwise

C	Minifix Cap		2PCS
---	-------------	---	------

Step 10 : Attach Extension Side and Back 3 (13,14) as of the way to install Extension 2.

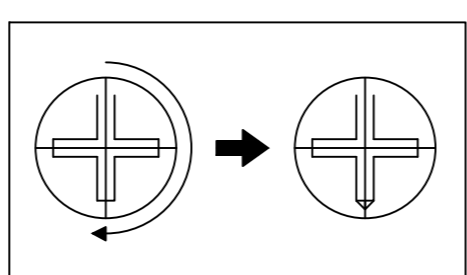
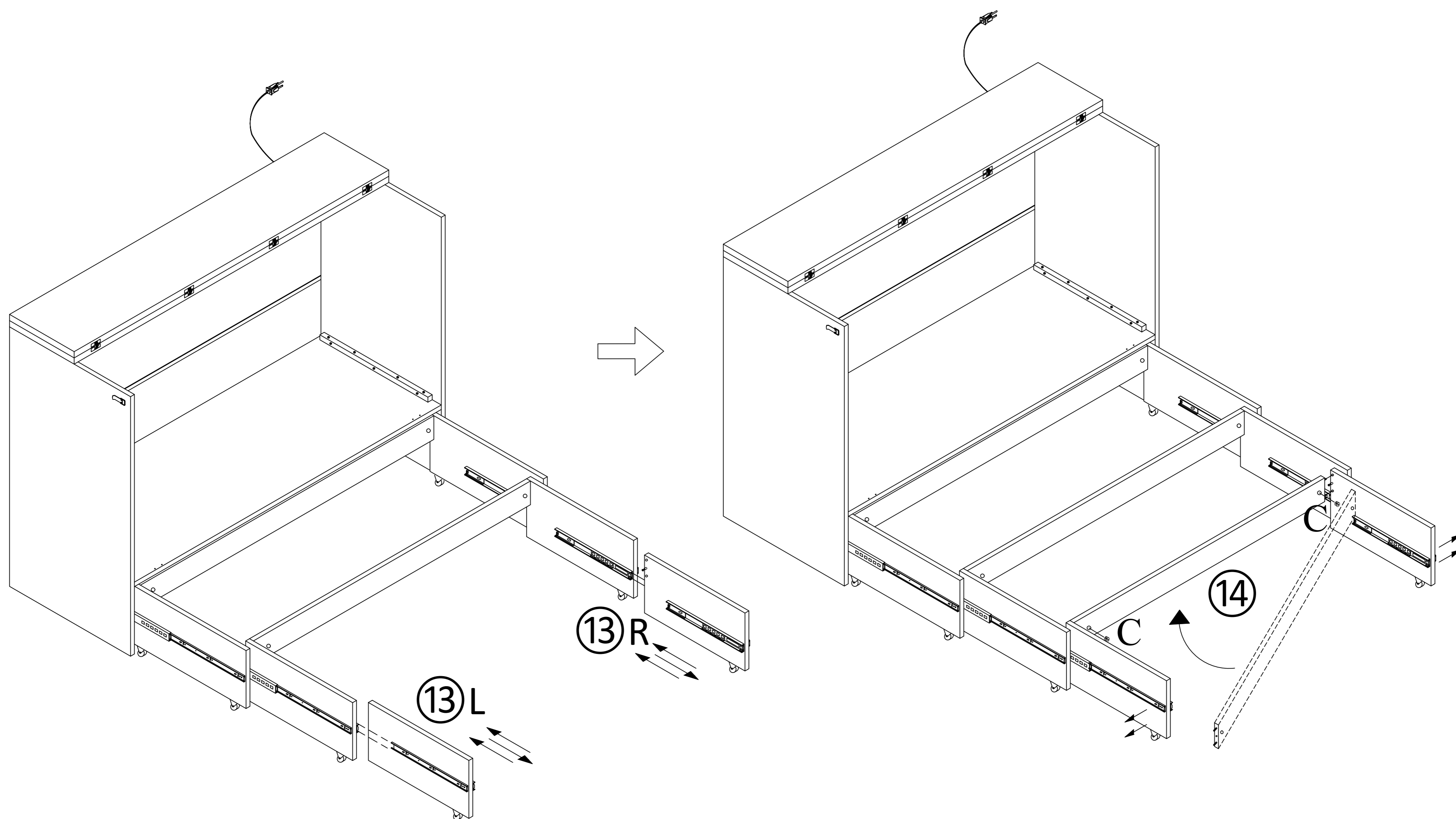

Lock Minifix cap clockwise

C	Minifix Cap		2PCS
---	-------------	---	------

Step 11 : Drawer assembly.

First connect Drawer Back (16) to Drawer Side (15) with Screw (M).

Slot the Drawer Base Support (17) into Drawer Back (16) and lock with cap (C). Next, slot in the Drawer Base (18).

Then, install the Handle with Screw (G) onto Drawer Front (19). Attach the Drawer Front (19) to the drawer box and lock with cap (C) and screw (M).

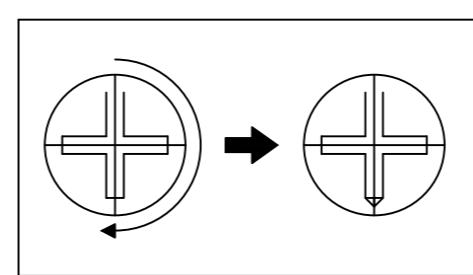
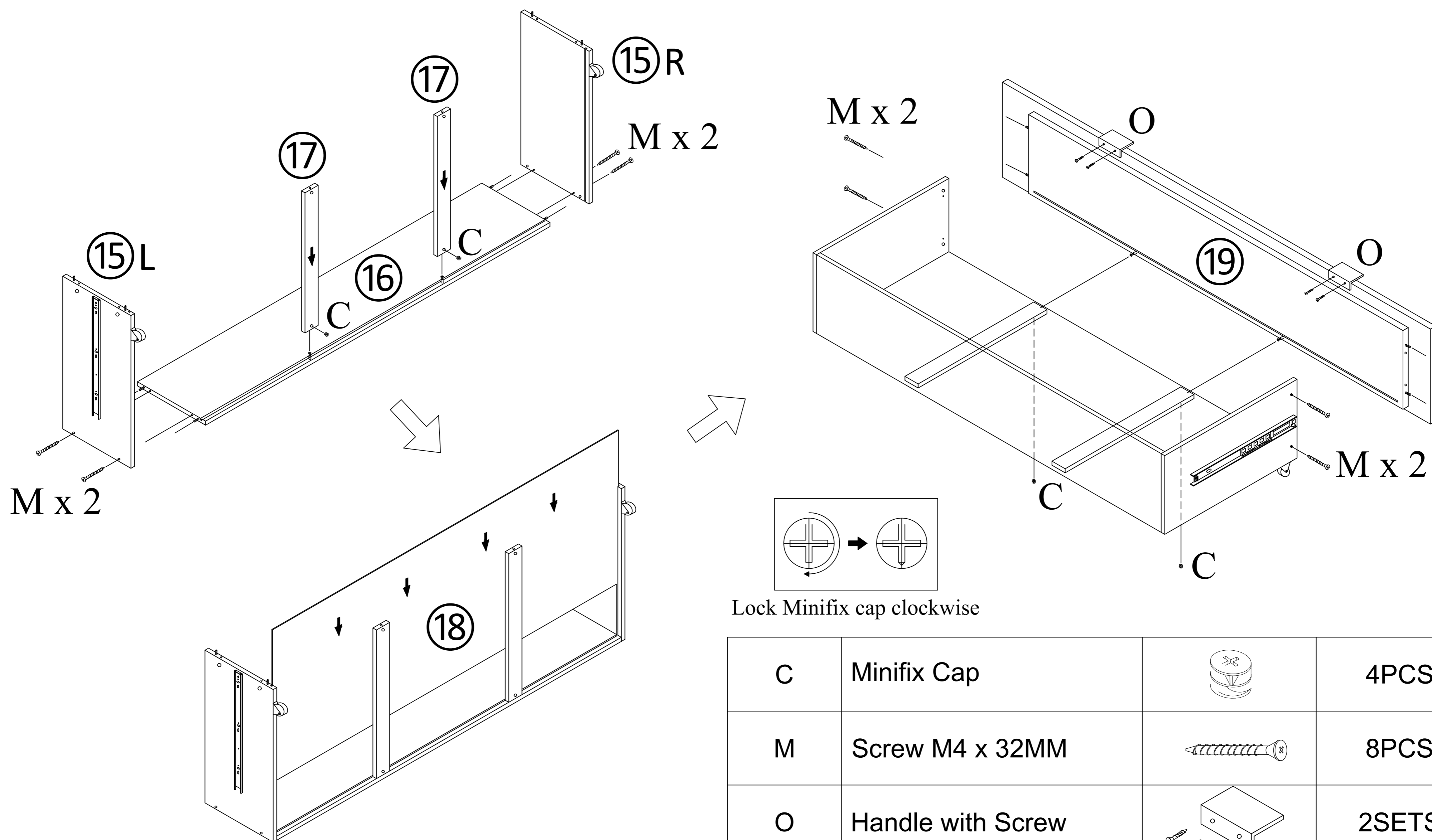

Lock Minifix cap clockwise

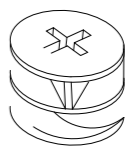
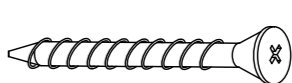
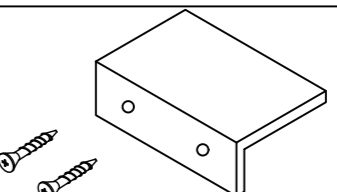
C	Minifix Cap		4PCS
M	Screw M4 x 32MM		8PCS
O	Handle with Screw		2SETS

Step 12 : Install Drawer Box as of previous steps.

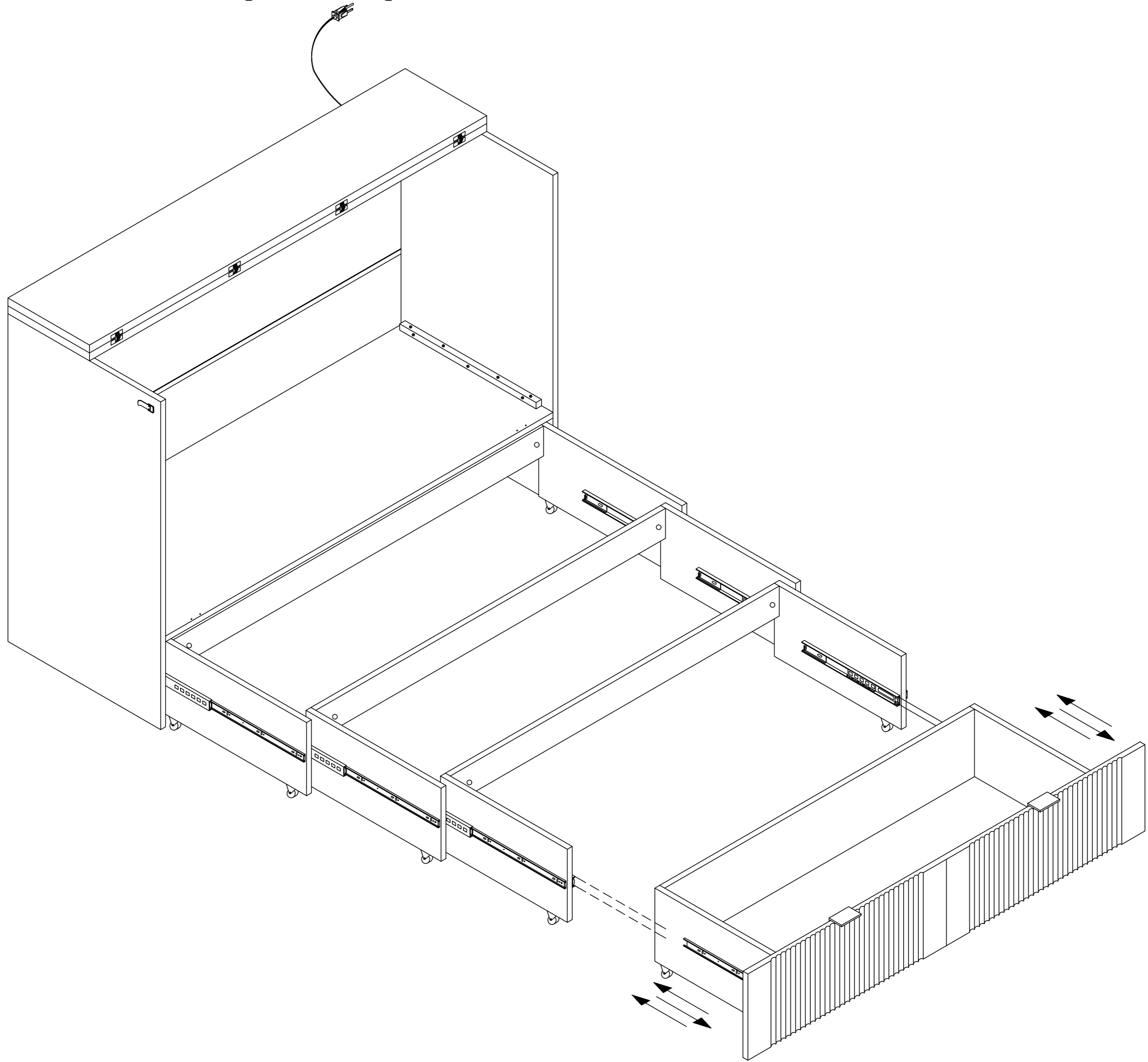

Step 13 : Attach the connected Doors (20) with screw (L).

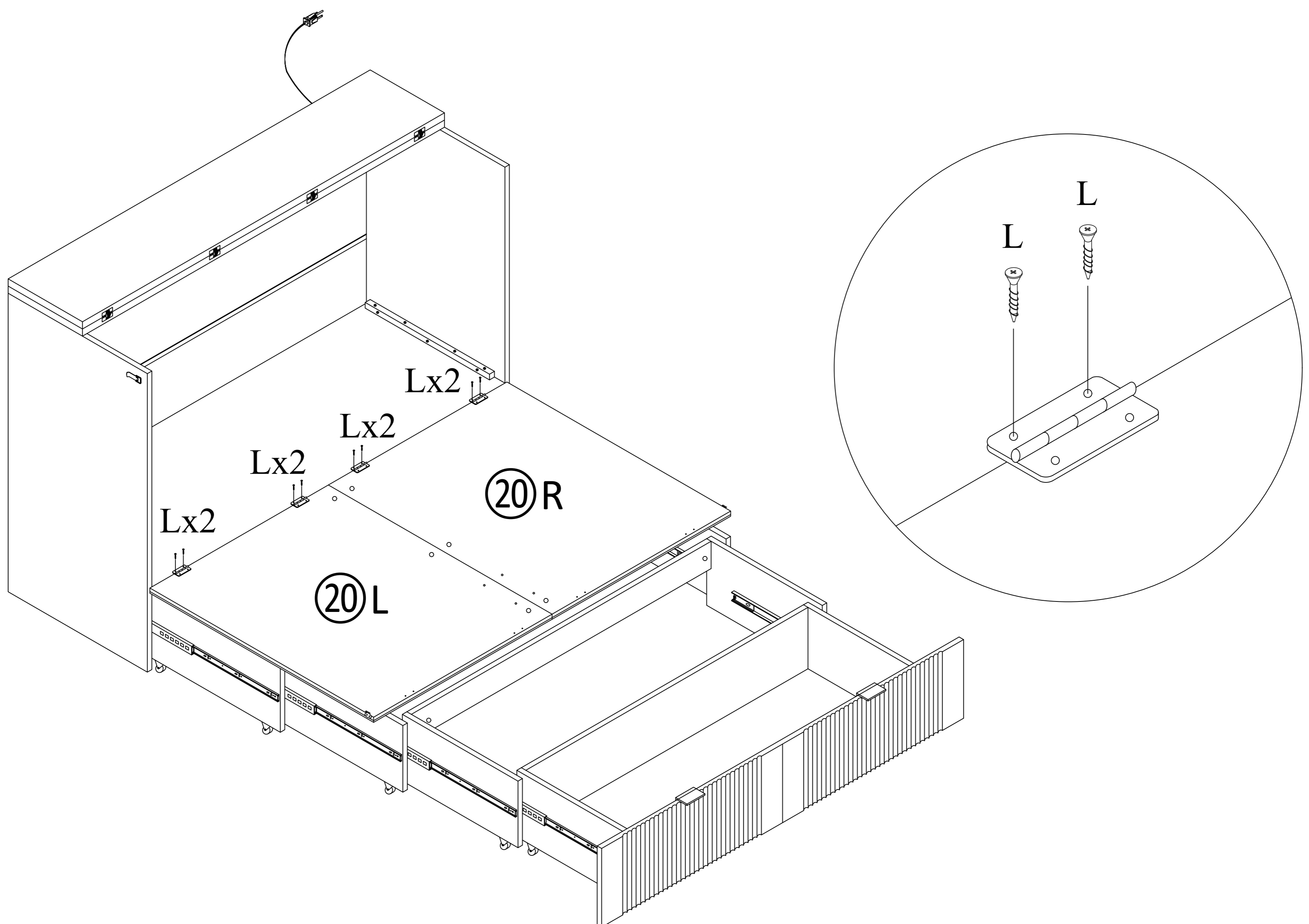

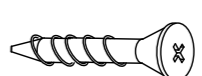
L	Screw M3.5 x 16MM		8PCS
---	-------------------	---	------

Step 13 : Attach the connected Support Panels (21) with screw (L).

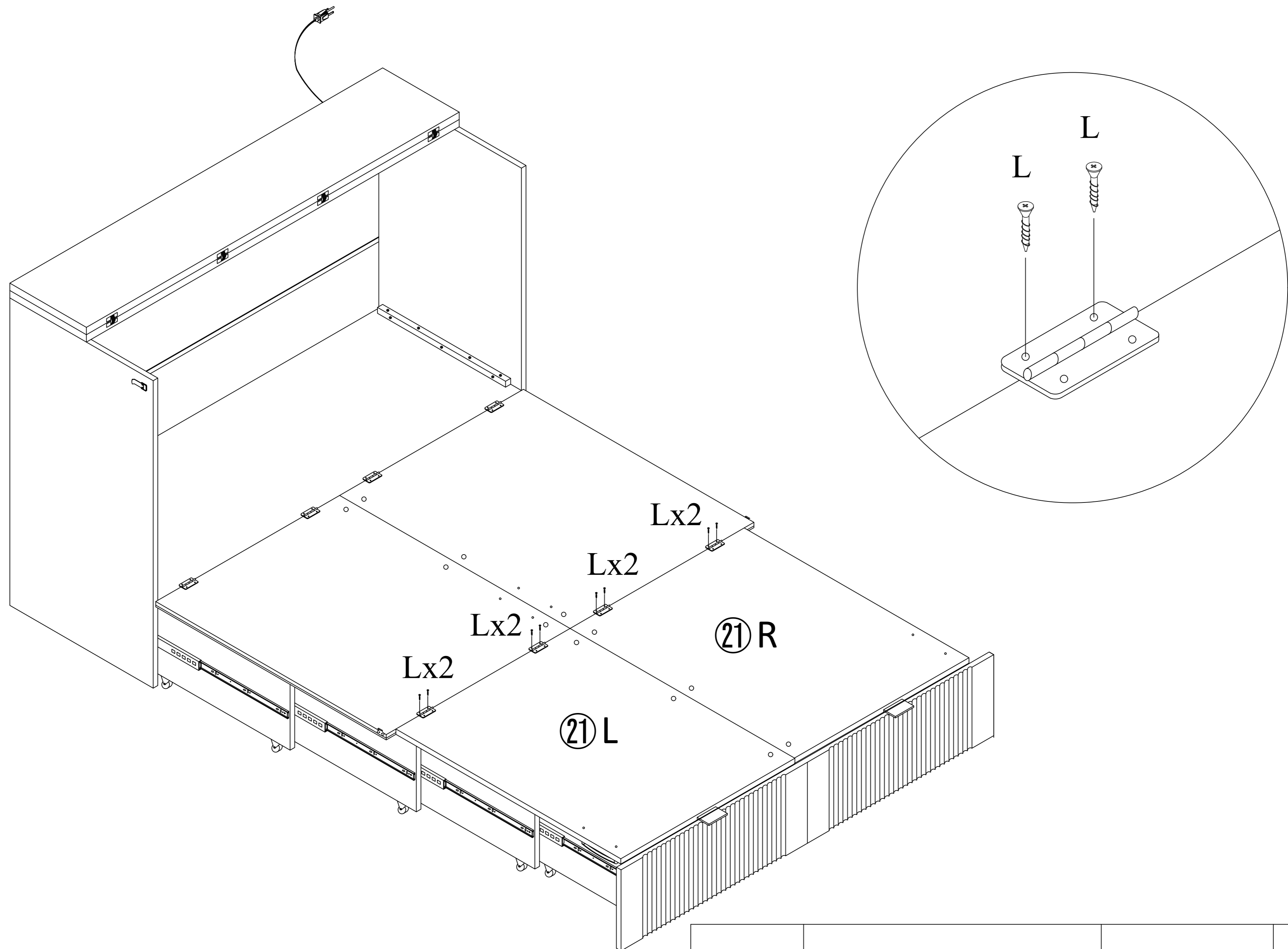

L

Screw M3.5 x 16MM



8PCS

Completed Assembly.

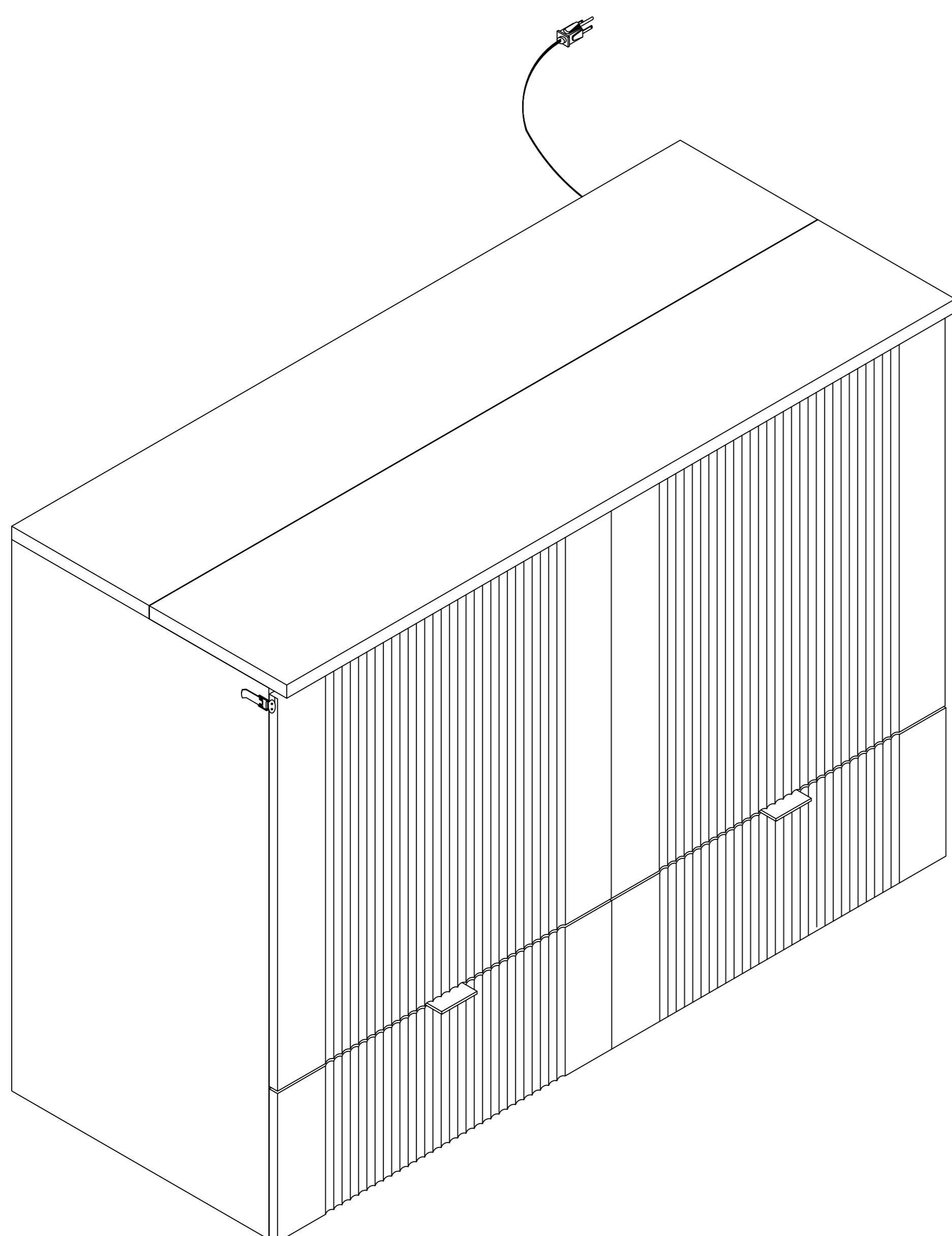

Left Side

Right Side

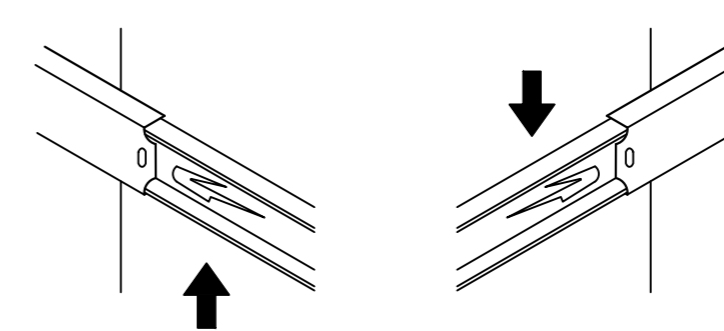

Disconnect Levers

To Remove Drawer, If Needed

- Pull the drawer fully open so levers are visible.
- Push UP on left side lever and DOWN on right side lever.
- Holding levers in place, pull drawer toward you.

REFER TO NEXT PAGE FOR  
WAY TO OPEN & CLOSE  
THIS BED.

**! IMPORTANT !**  
**ALWAYS PULL THE  
DRAWER OUT FIRST  
BEFORE OPEN THIS  
CHEST**

To keep the bed at it's minimal size, follow the steps below.

1. Fold up Support Panels (21)

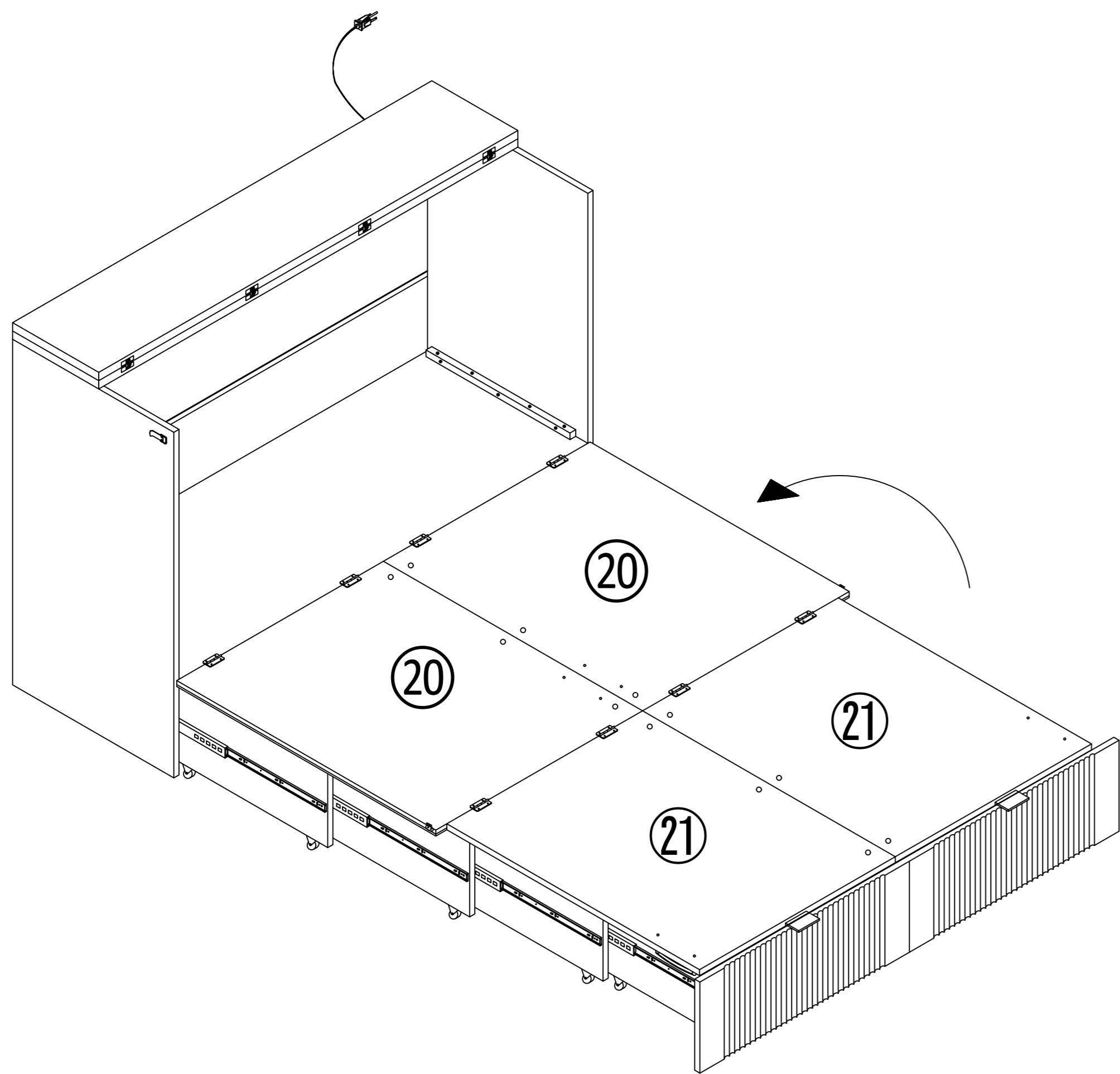

4. Push Drawer and Extension Sides in.

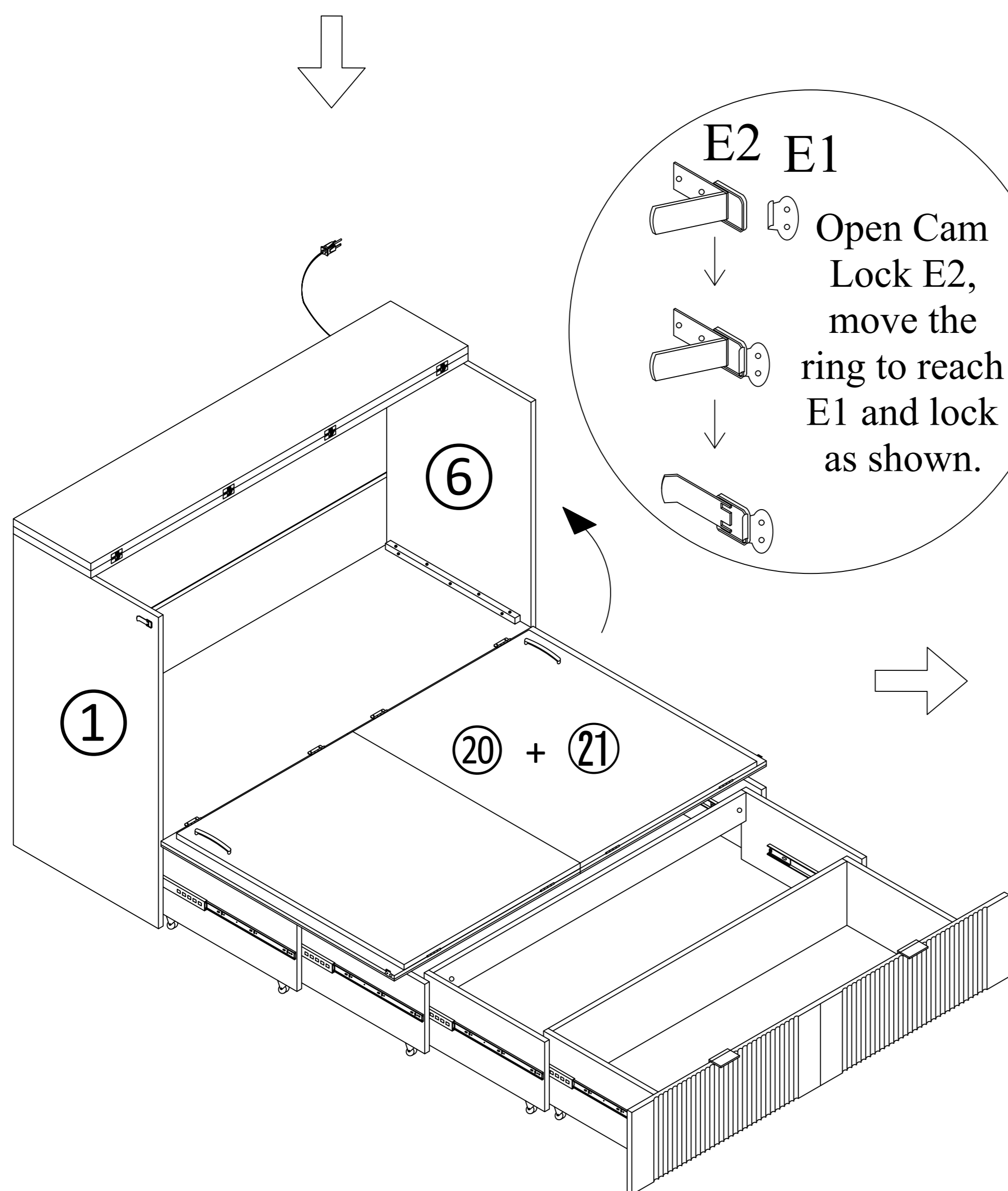
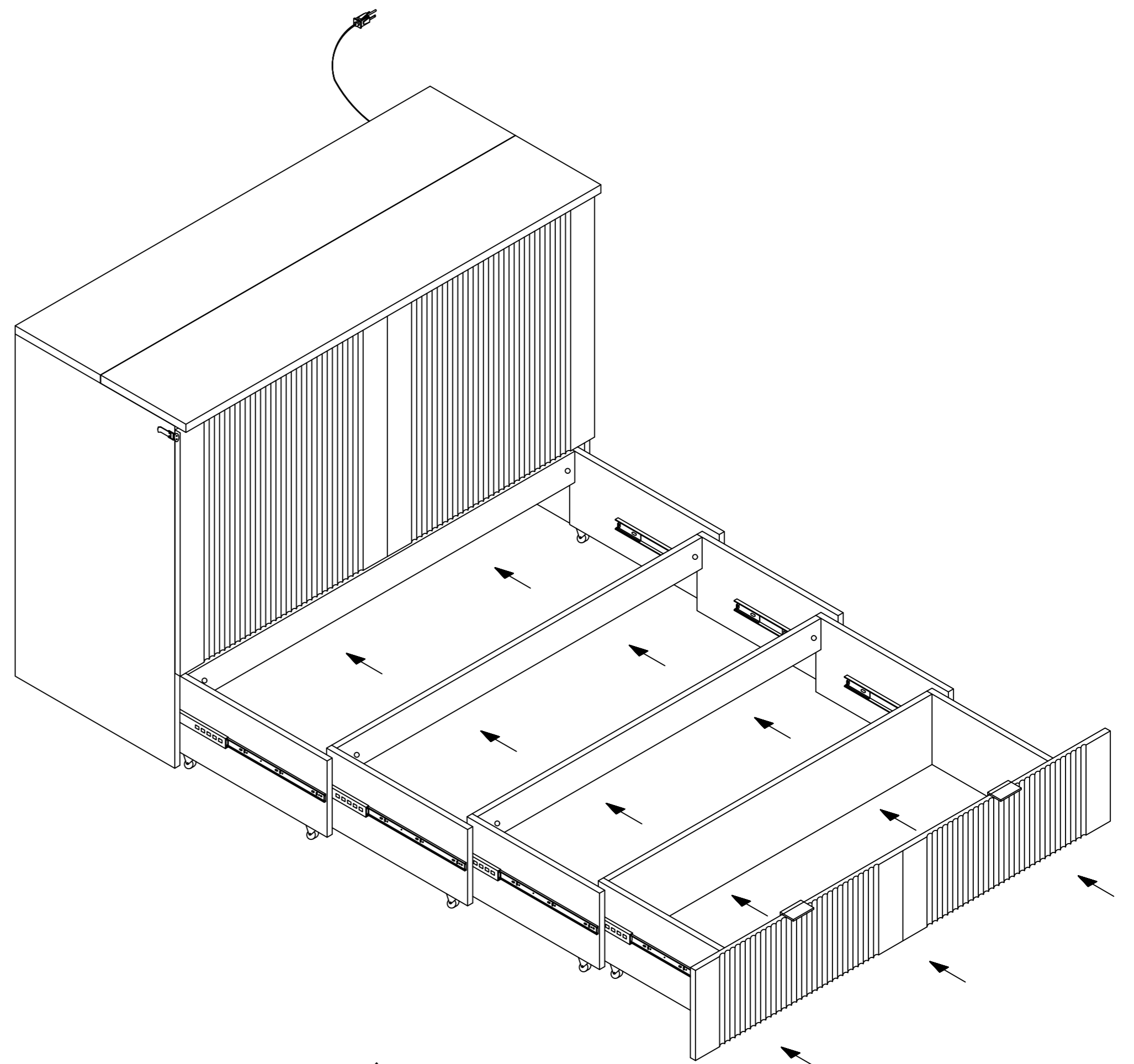

2. Fold up Doors (20) and support panels (21) and lock cam lock on Side Panels (1,6).

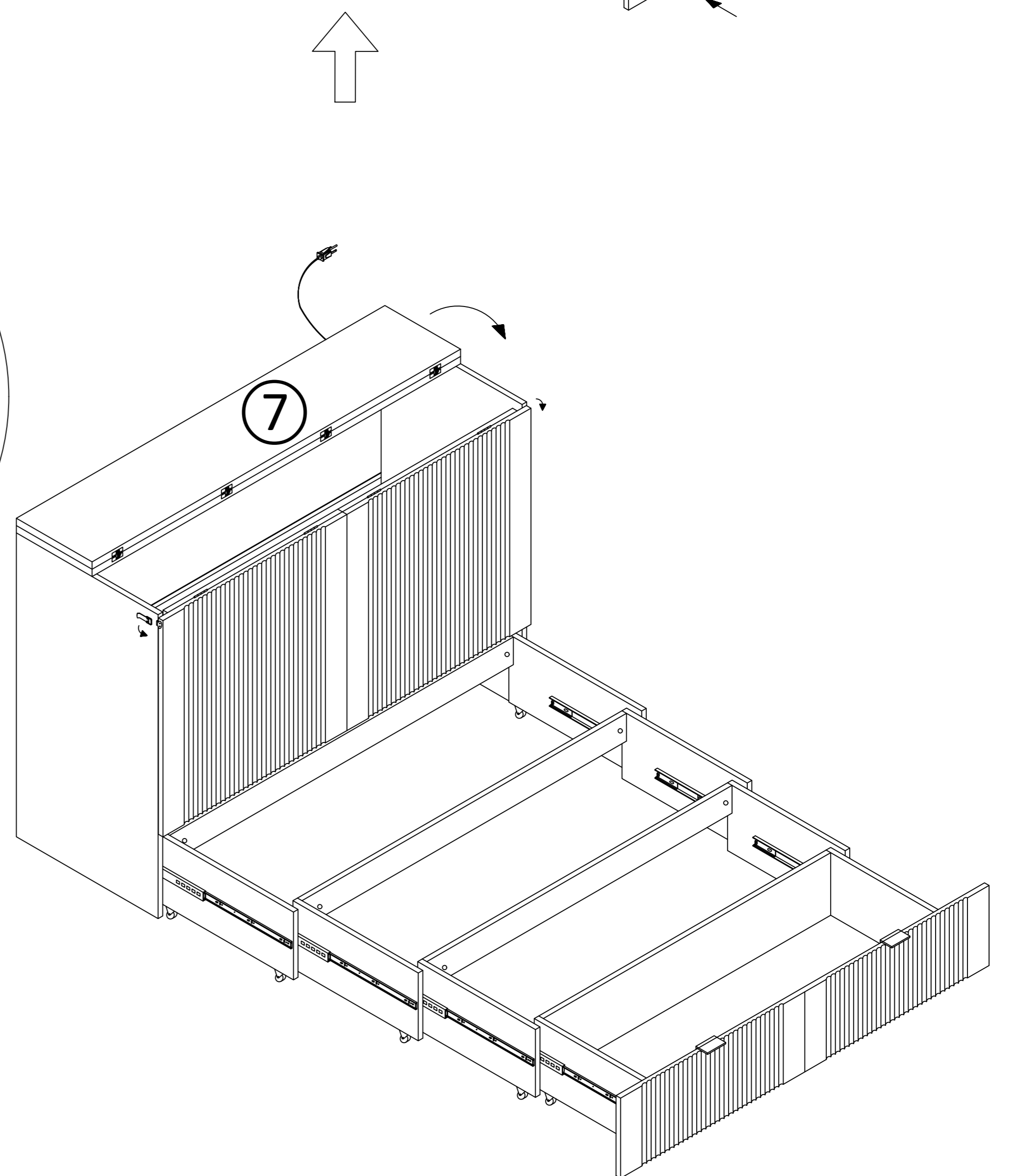

3. Fold Top Panel(7)

3. To use the bed, **PULL THE DRAWER OUT BEFORE PUTTING DOORS/PANELS DOWN.** Failing to do so will cause damages to the furniture.\*