

---

# Installation & Assembly

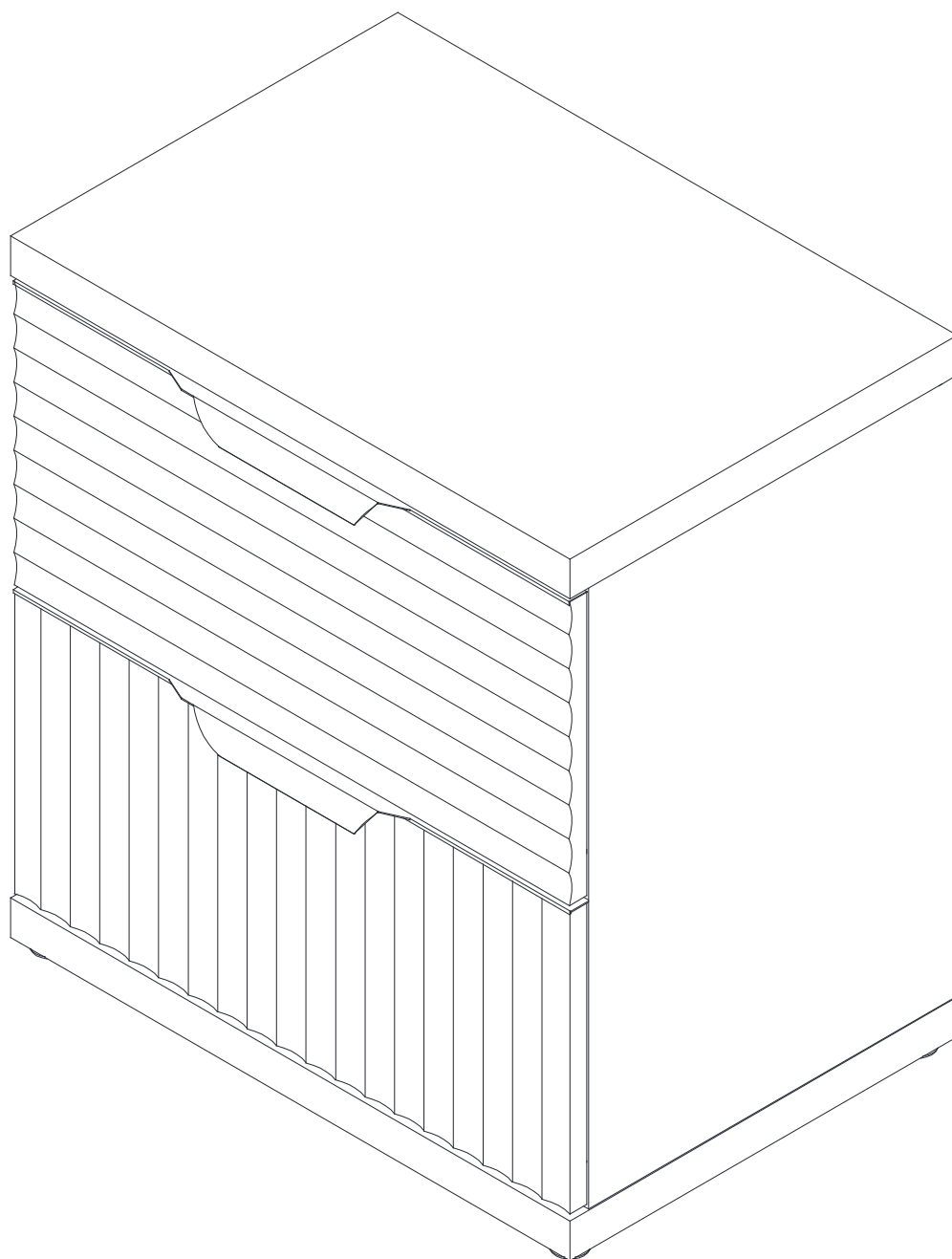

# Assembly Instructions

Before beginning the assembly process, please read and save these instructions for reference. Following these guidelines will ensure a smooth and successful assembly of your product.

## 1. Part Identification:

Carefully separate and identify all the parts included in your package. Confirm that you have all the components listed in the instruction manual. This step will help you avoid any missing or misplaced parts during assembly.

## 2. Work Surface:

To prevent any scratches or damage to the product, assemble it on a soft mat or a similar protective surface. This will provide a cushioned area for the components and protect the surfaces from unwanted marks.

## 3. Step-by-Step Assembly:

Follow the assembly instructions provided, proceeding one step at a time. Take care to understand each step properly before proceeding to the next one. This sequential approach ensures that the assembly is done correctly and minimizes the chance of errors.

## 4. Proper Screw Seating:

When attaching screws and nuts, it is essential not to fully tighten them until all screws are correctly seated. By partially tightening each screw and nut initially, you can ensure that they are aligned properly and fit securely before final tightening.







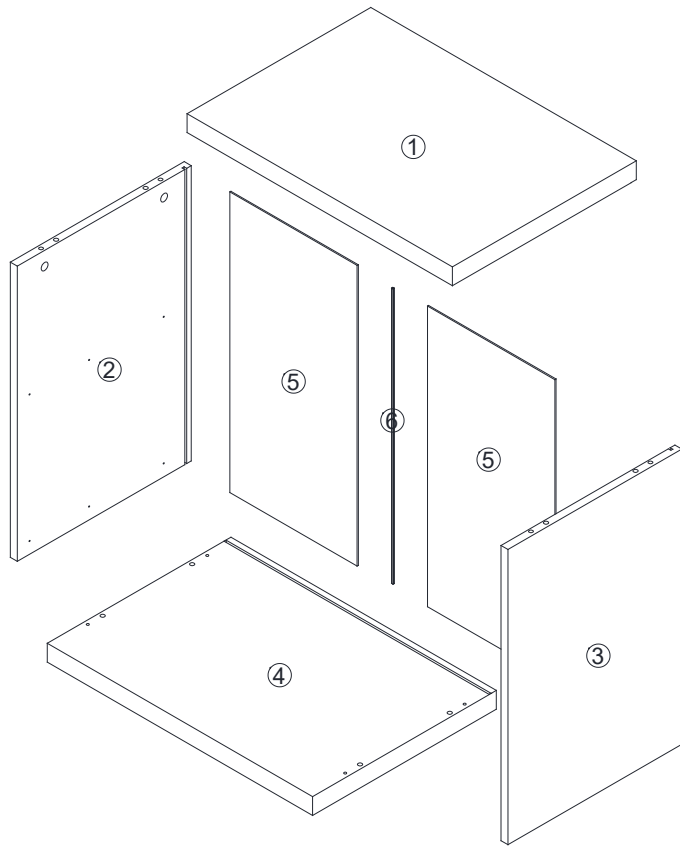
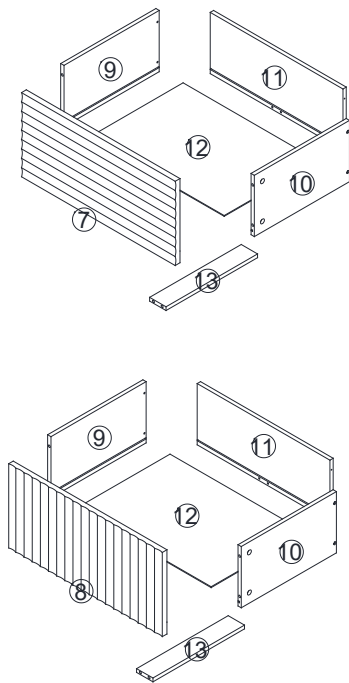





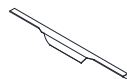
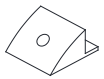

## 5. Avoid Over-Tightening:

While each screw and nut should be tightened correctly, it is crucial not to over-tighten them. Over-tightening can cause damage to the product or compromise its structural integrity. Use the appropriate amount of force to secure the components without excessive tightening.

# Parts List



# Hardware List

|   |  |  |   |  |  |  |  |
|---|--|--|---|--|--|--|--|
| A x16<br><br>Ø6x35     | B x16<br><br>Ø15x10 | C x8<br><br>Ø8x30 | D x12<br><br>Ø8xM4x35  | E x24<br><br>Ø6.5xM3x12 | F x4<br><br>Ø10xM5x55 | G x2<br>          | H x10<br>         |
| I x10<br><br>Ø6.5x3x16 | J x4<br>            | K x1<br><br>M4    | L x6<br><br>Ø6.5xM3x14 | CLx2<br><br>350MM       | CRx2<br><br>350MM      | DLx2<br><br>350MM | DRx2<br><br>350MM |

| Code | Description   | Quantity |
|------|---------------|----------|
| A    | Cam bolt      | 16+2     |
| B    | Cam lock      | 16+2     |
| C    | Wooden dowel  | 8+2      |
| D    | M4x35MM Screw | 12+2     |
| E    | M3x12MM Screw | 24+2     |
| F    | M5x55MM Screw | 4+1      |
| G    | Handle        | 2        |
| H    | Back clip     | 10+2     |

| Code | Description             | Quantity |
|------|-------------------------|----------|
| I    | M3x16MM Screw           | 10+2     |
| J    | Adjusting the footrest  | 4        |
| K    | Wrench                  | 1        |
| L    | M3x14MM Screw           | 6+1      |
| CL   | 350mm Drawer runner set | 2        |
| CR   | 350mm Drawer runner set | 2        |
| DL   | 350mm Drawer runner set | 2        |
| DR   | 350mm Drawer runner set | 2        |

# Step 1

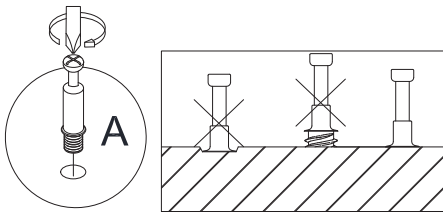
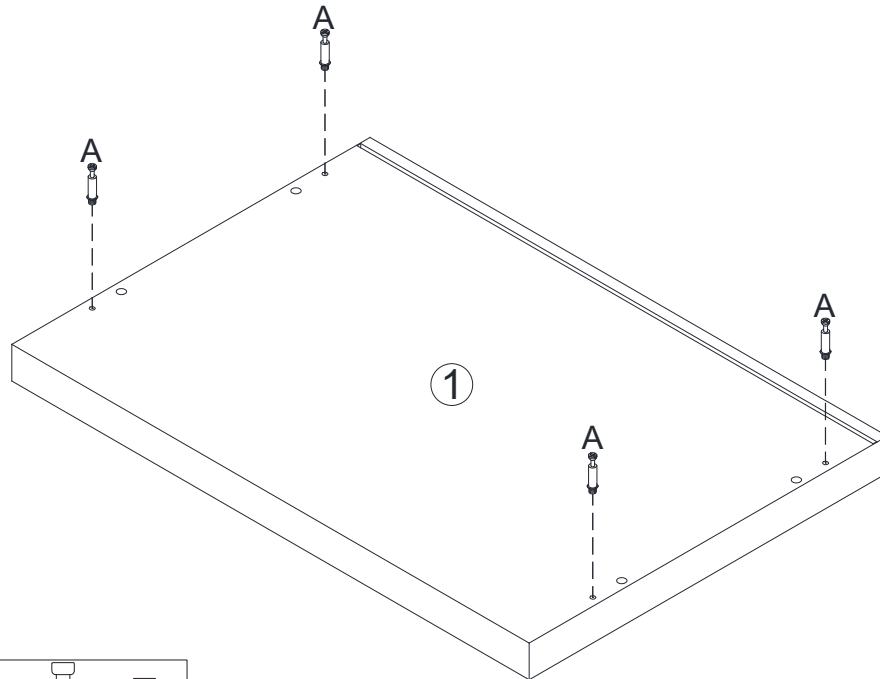

**A**

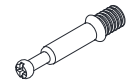

**X 4**

# Step 2

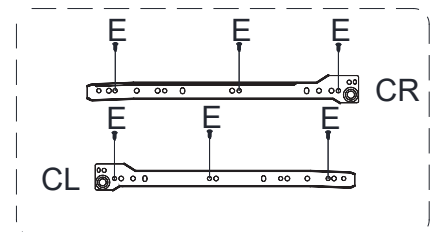

**E**



**X 6**



**CL**

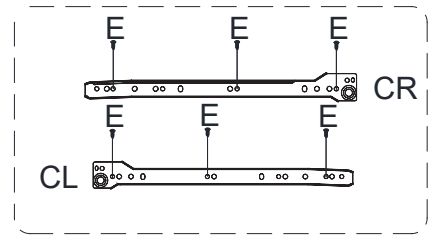
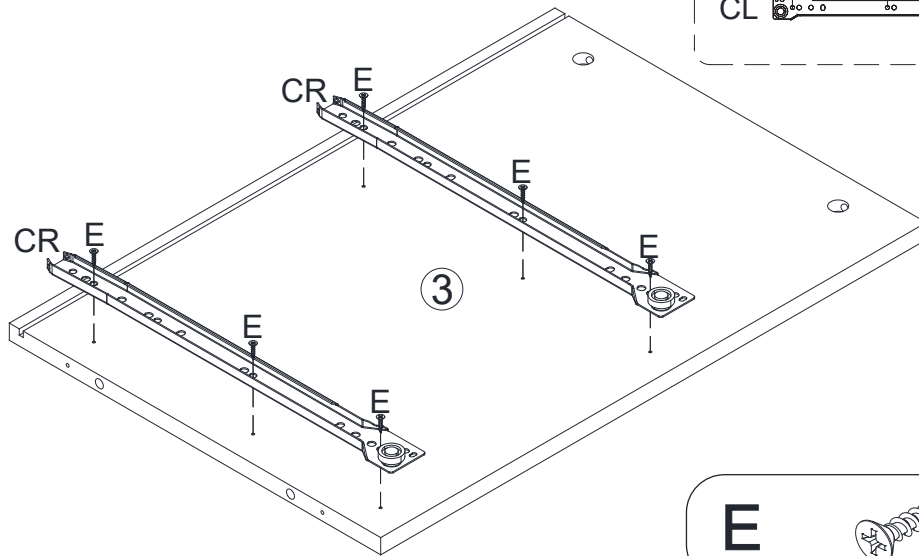

**X 2**

# Step 3



- E**  X 6
- CR**  X 2

# Step 4

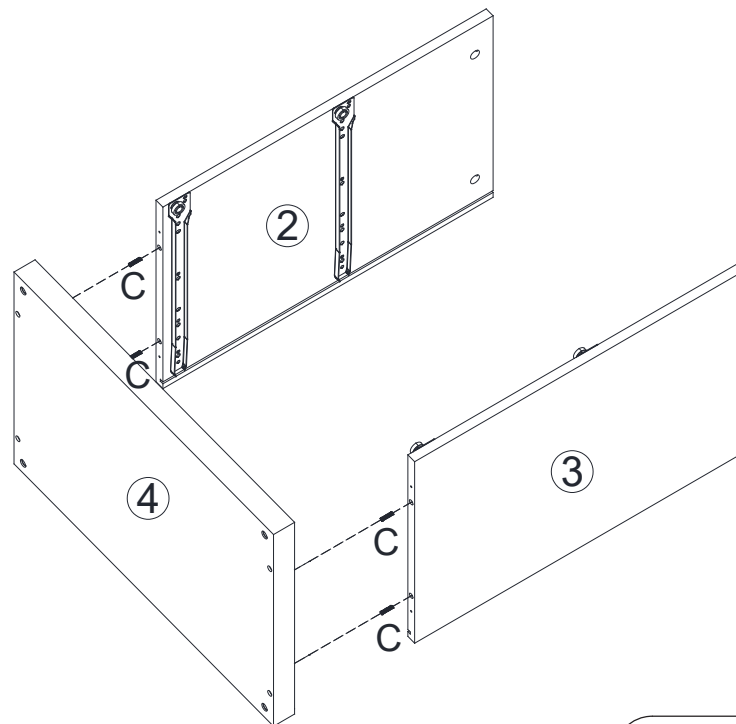

- C**  X 4

## Step 5

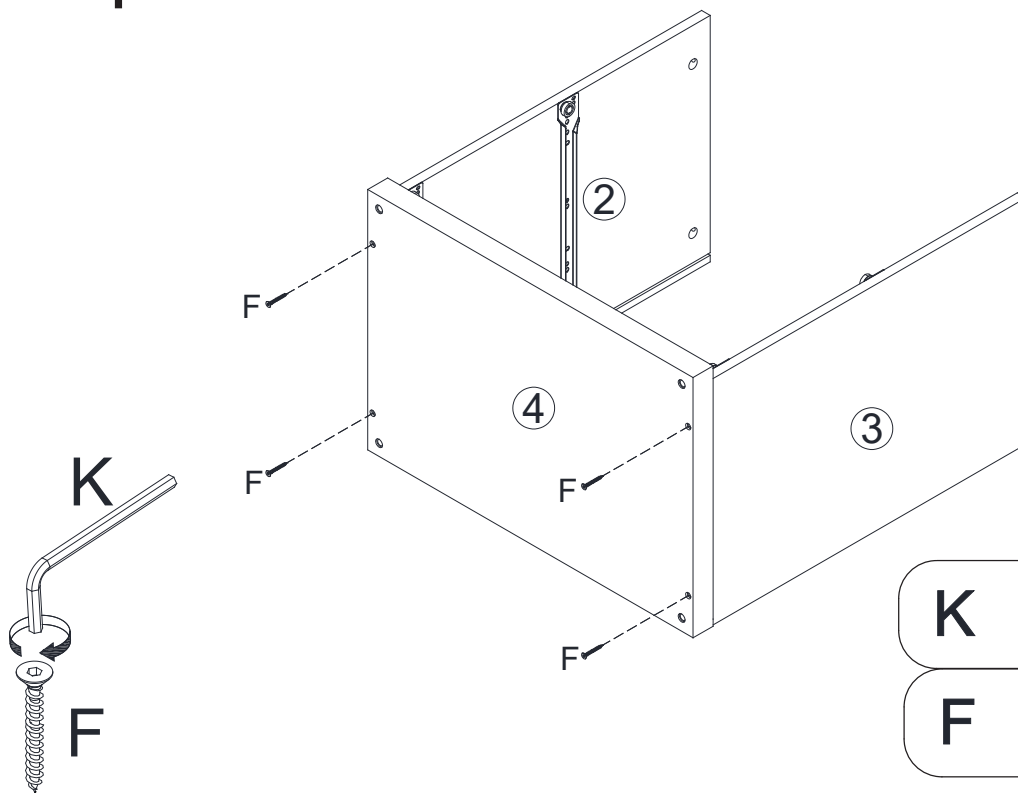

## Step 6

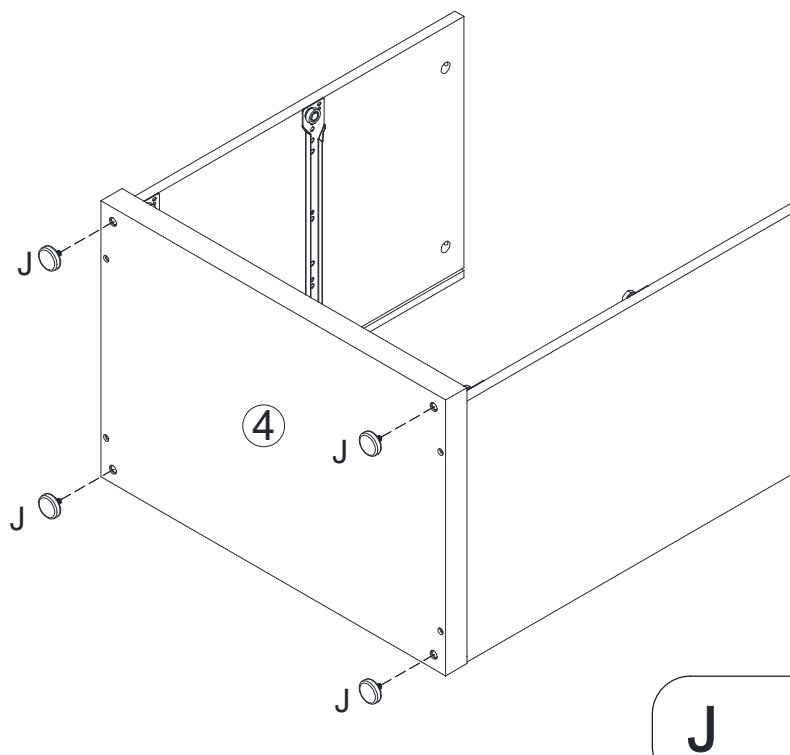

## Step 7

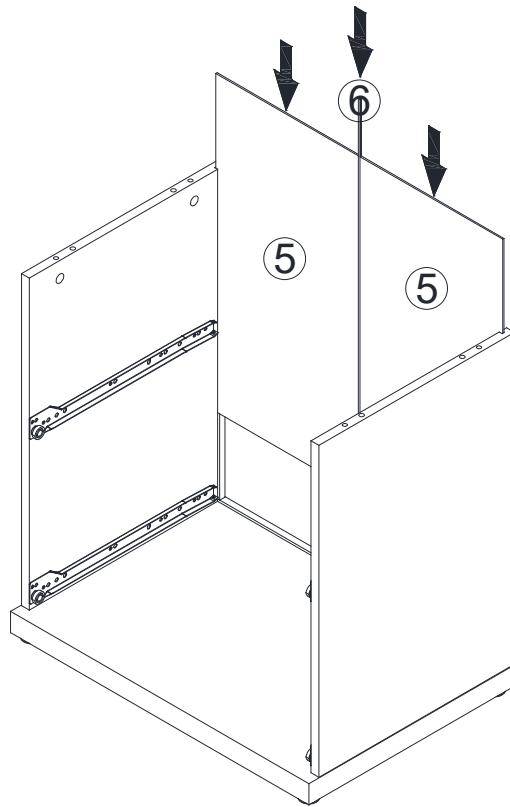

## Step 8

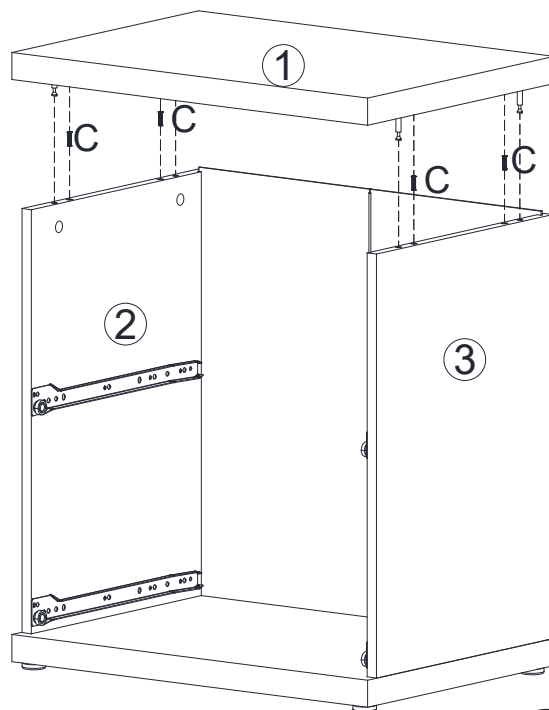

C



X 4

## Step 9

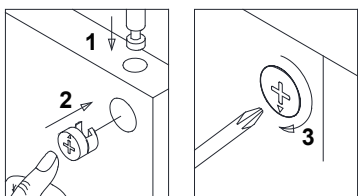
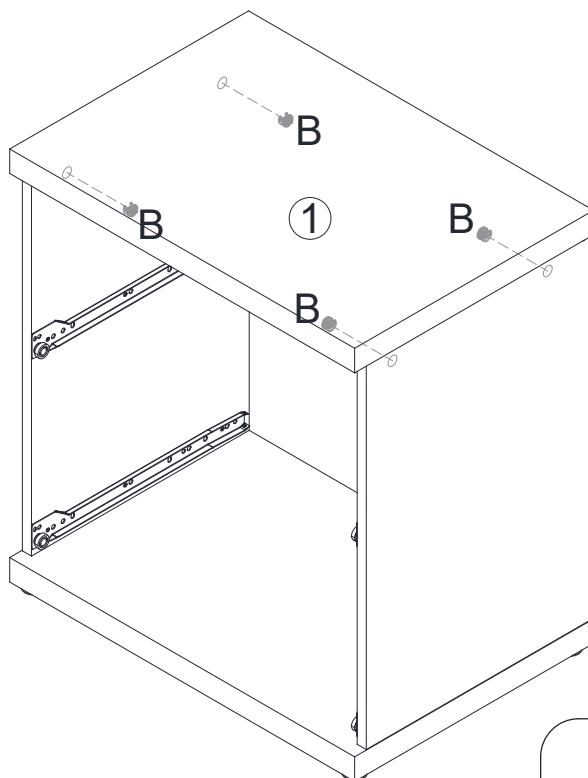

**B**



**X 4**

## Step 10

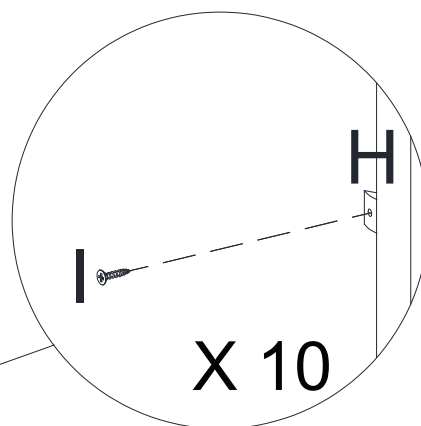
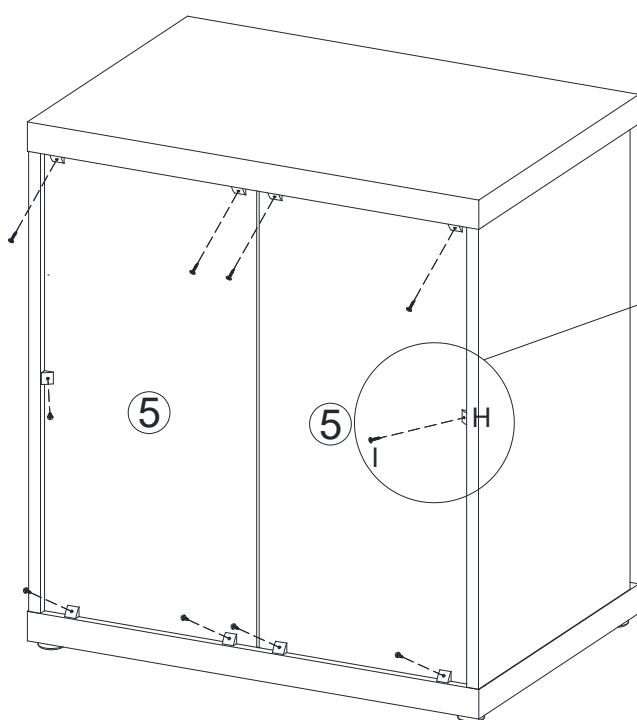

**I**



**X 10**

**H**



**X 10**

# Step 11

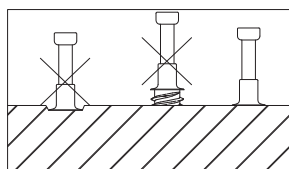
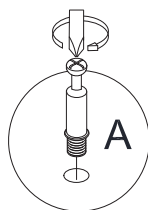
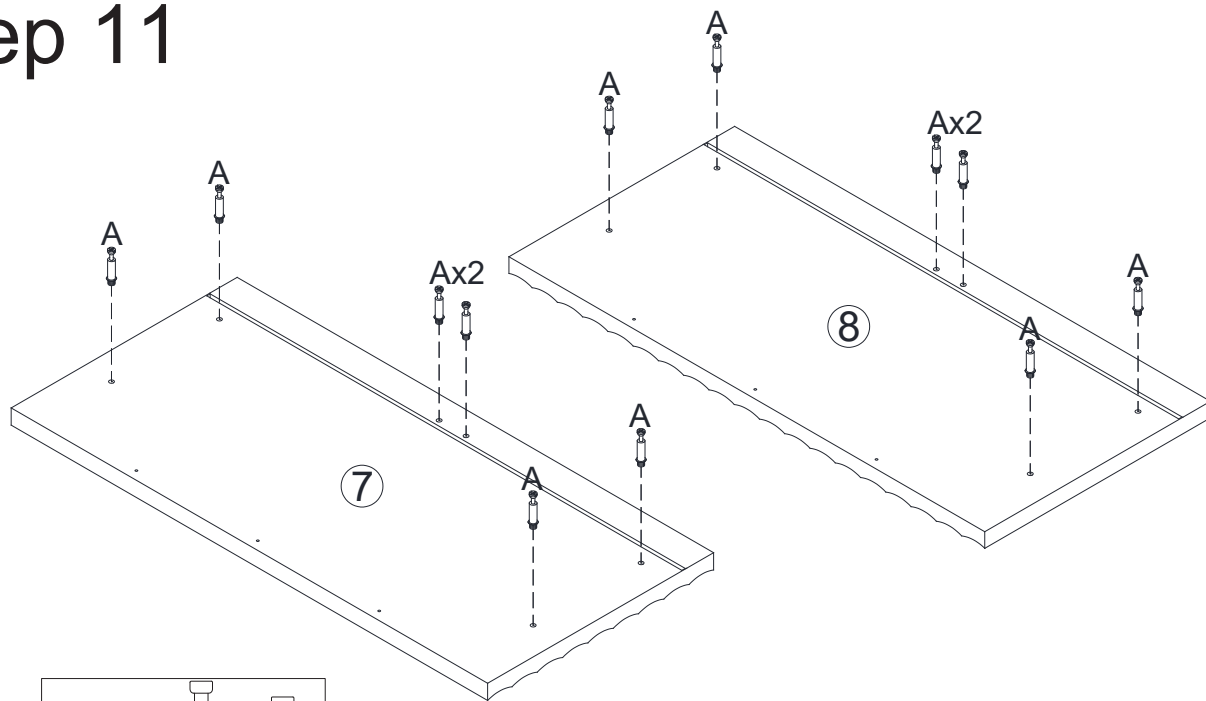

**A**

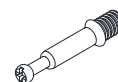

**X 12**

# Step 12

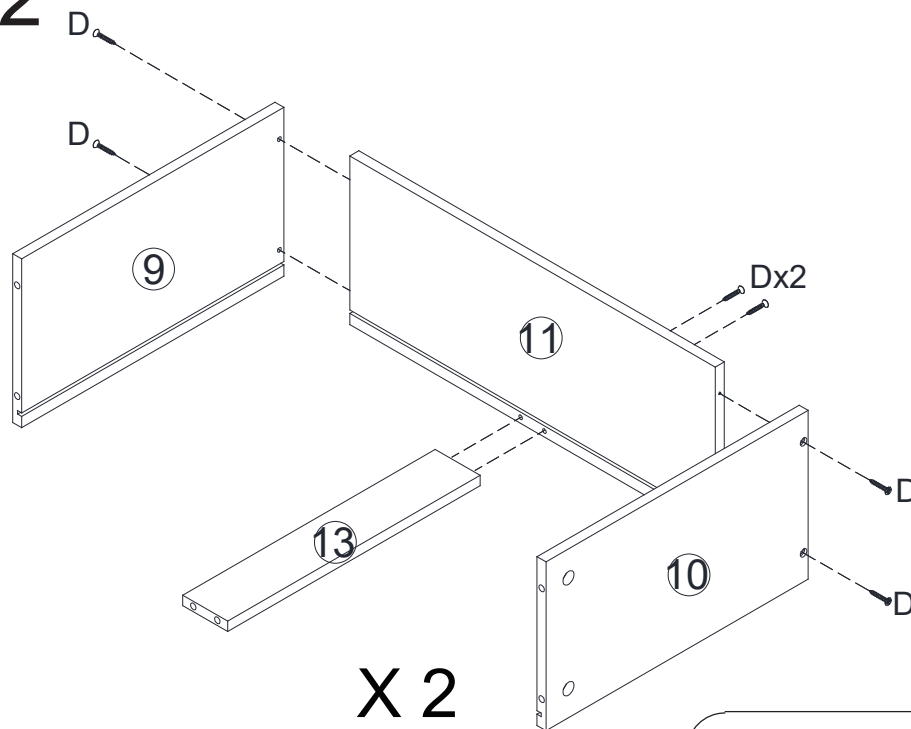

**X 2**

**D**



**X 12**

# Step 13

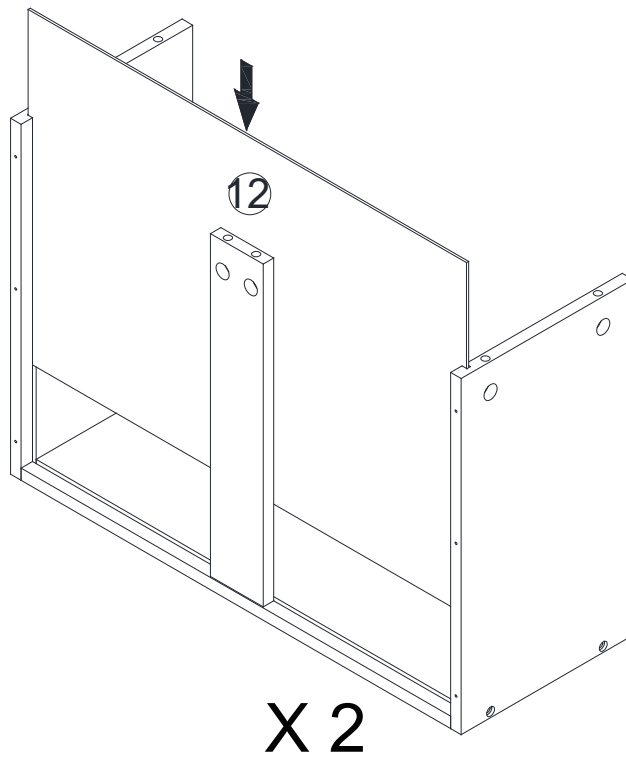

# Step 14

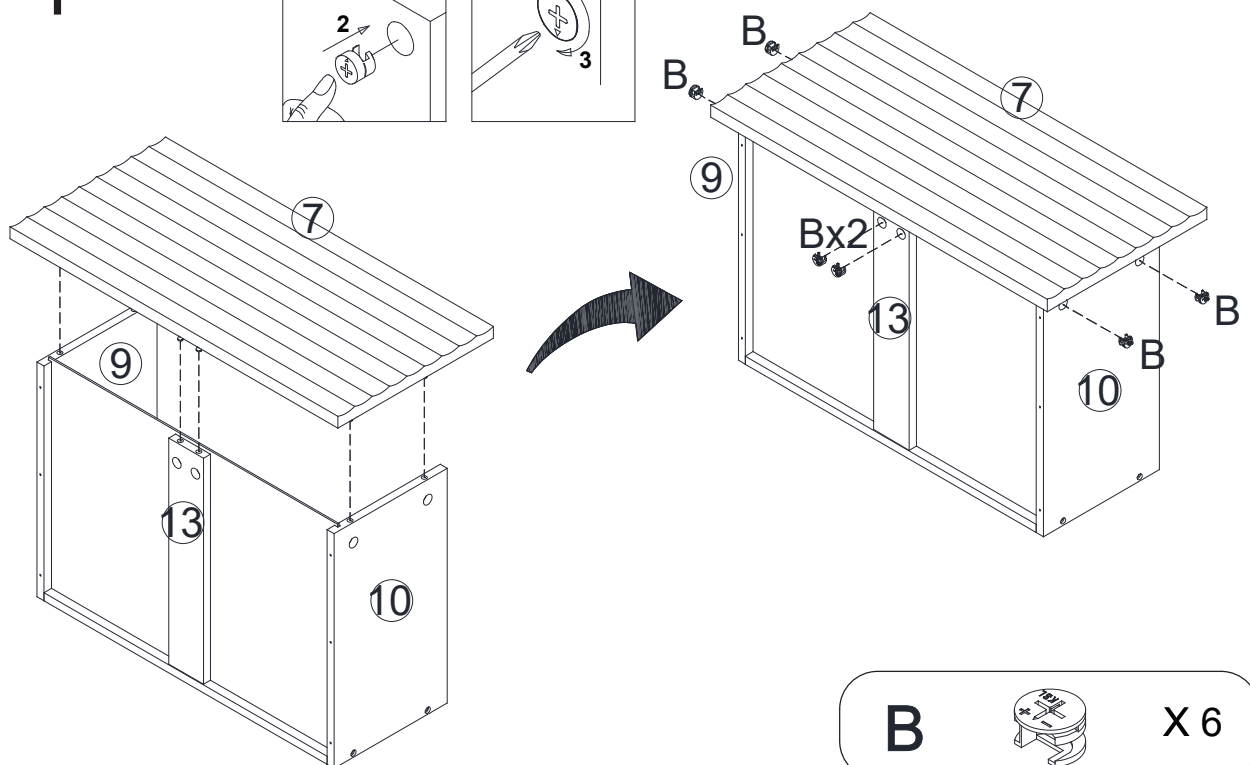
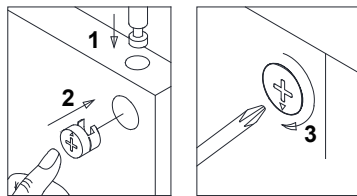

# Step 15

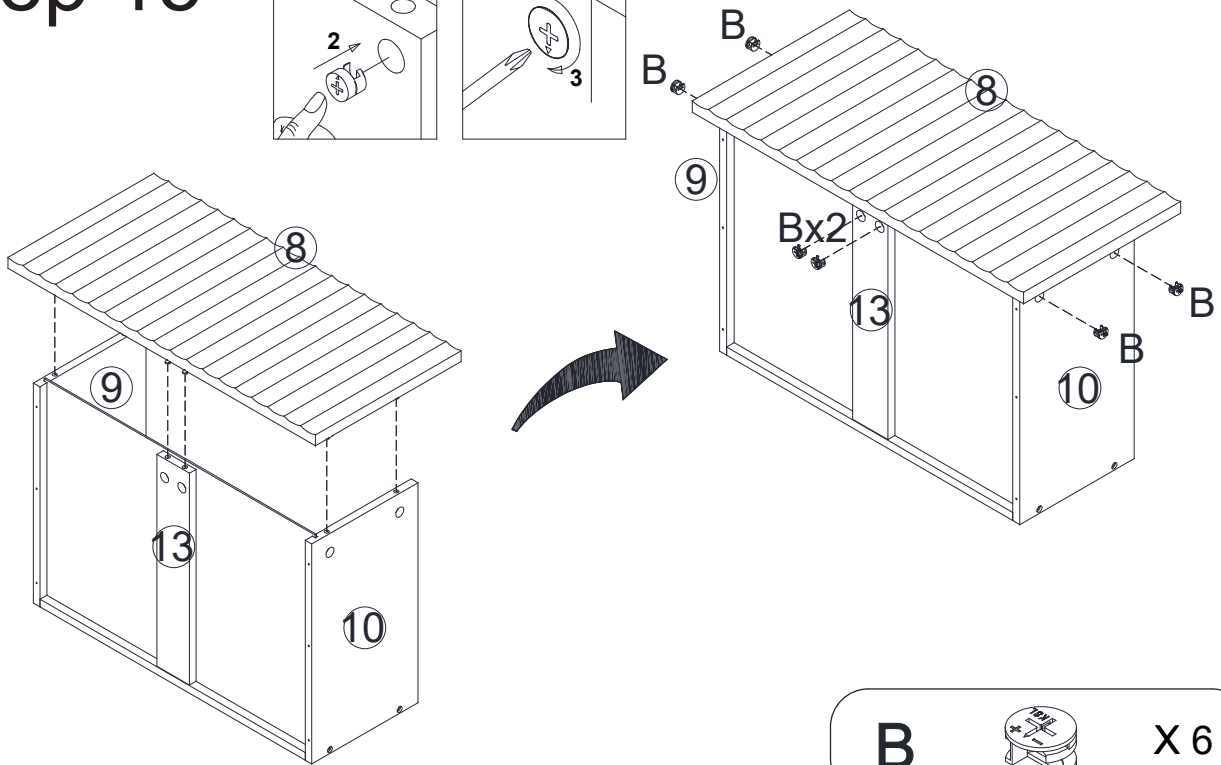
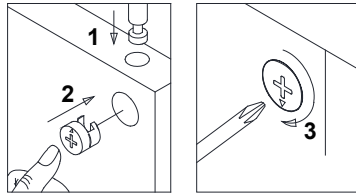

**B**  **X 6**

# Step 16

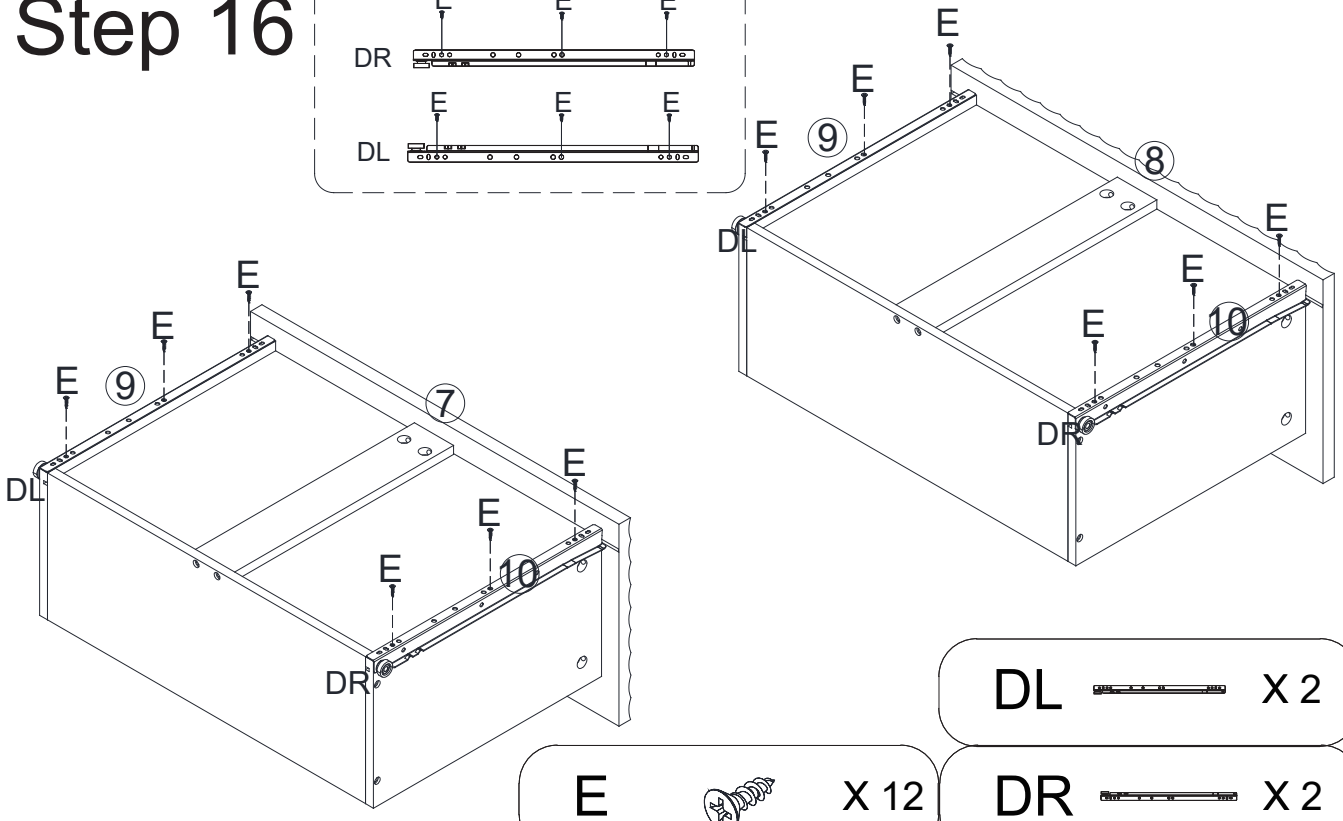
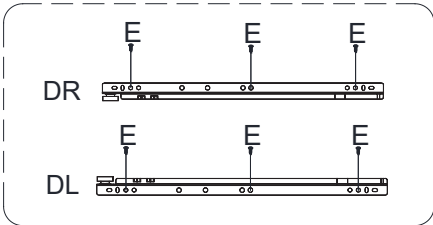



**DL**  **X 2**

**E**  **X 12**

**DR**  **X 2**

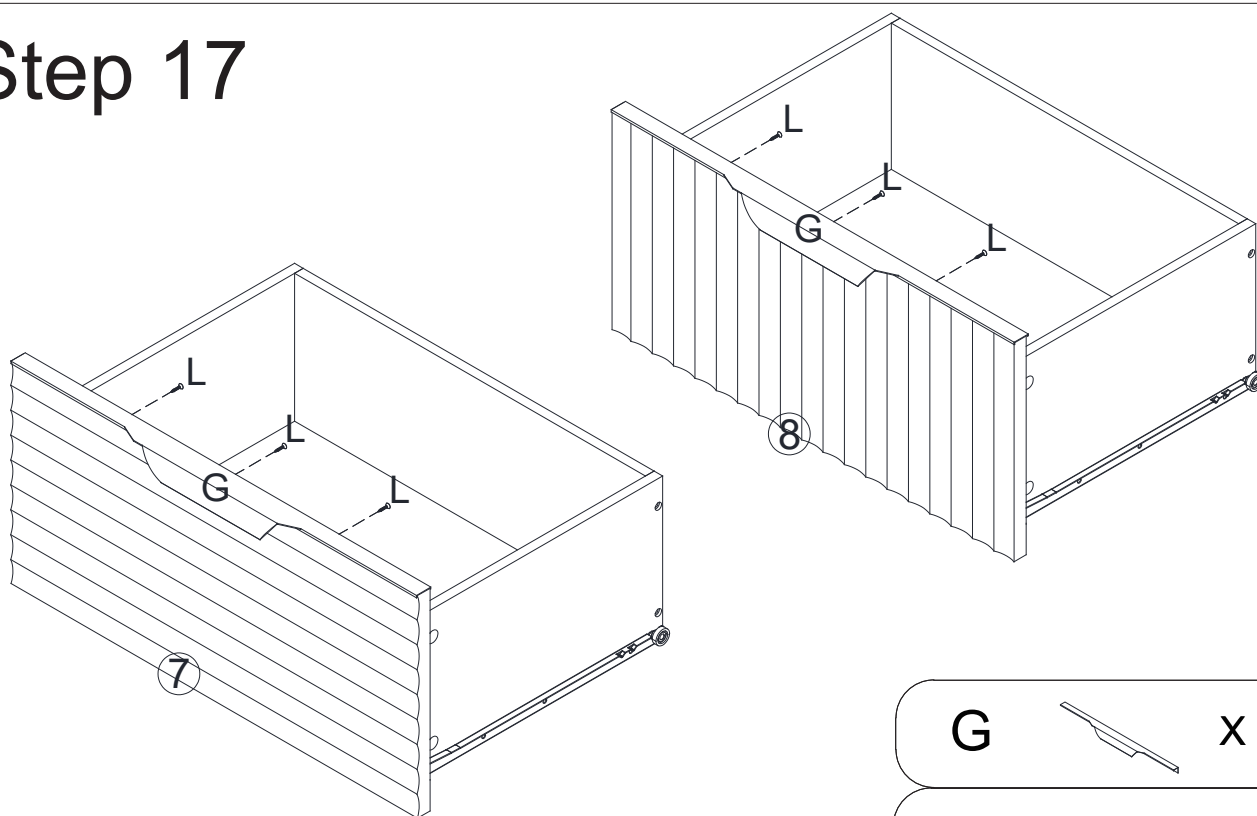
# Step 17



- G  X 2
- L  X 6

# Step 18

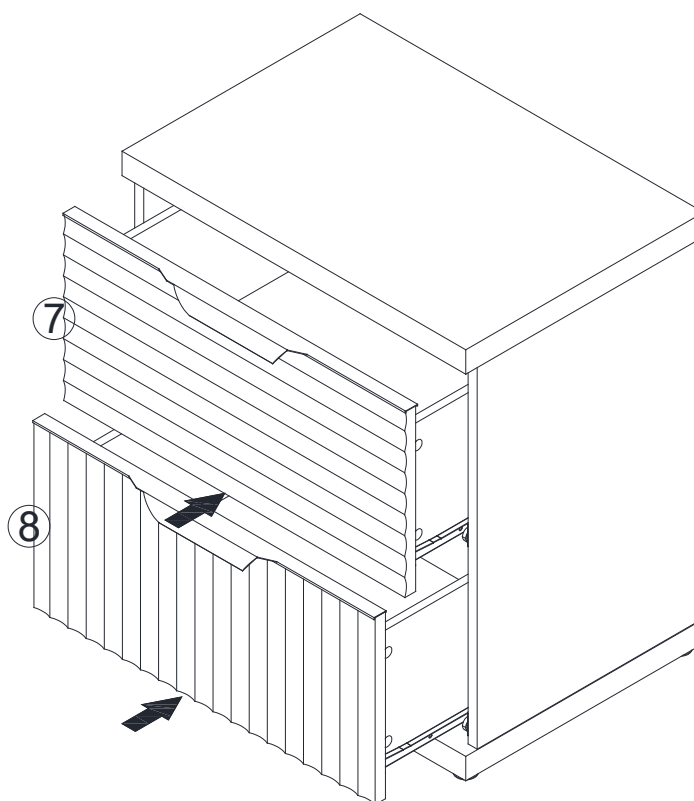
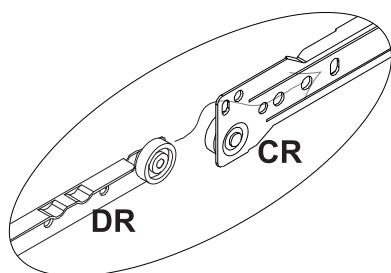
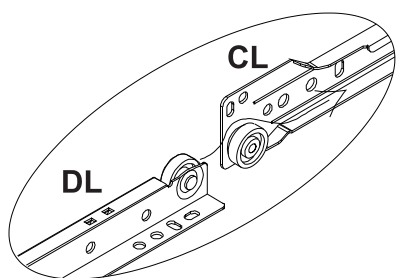

# Step 19

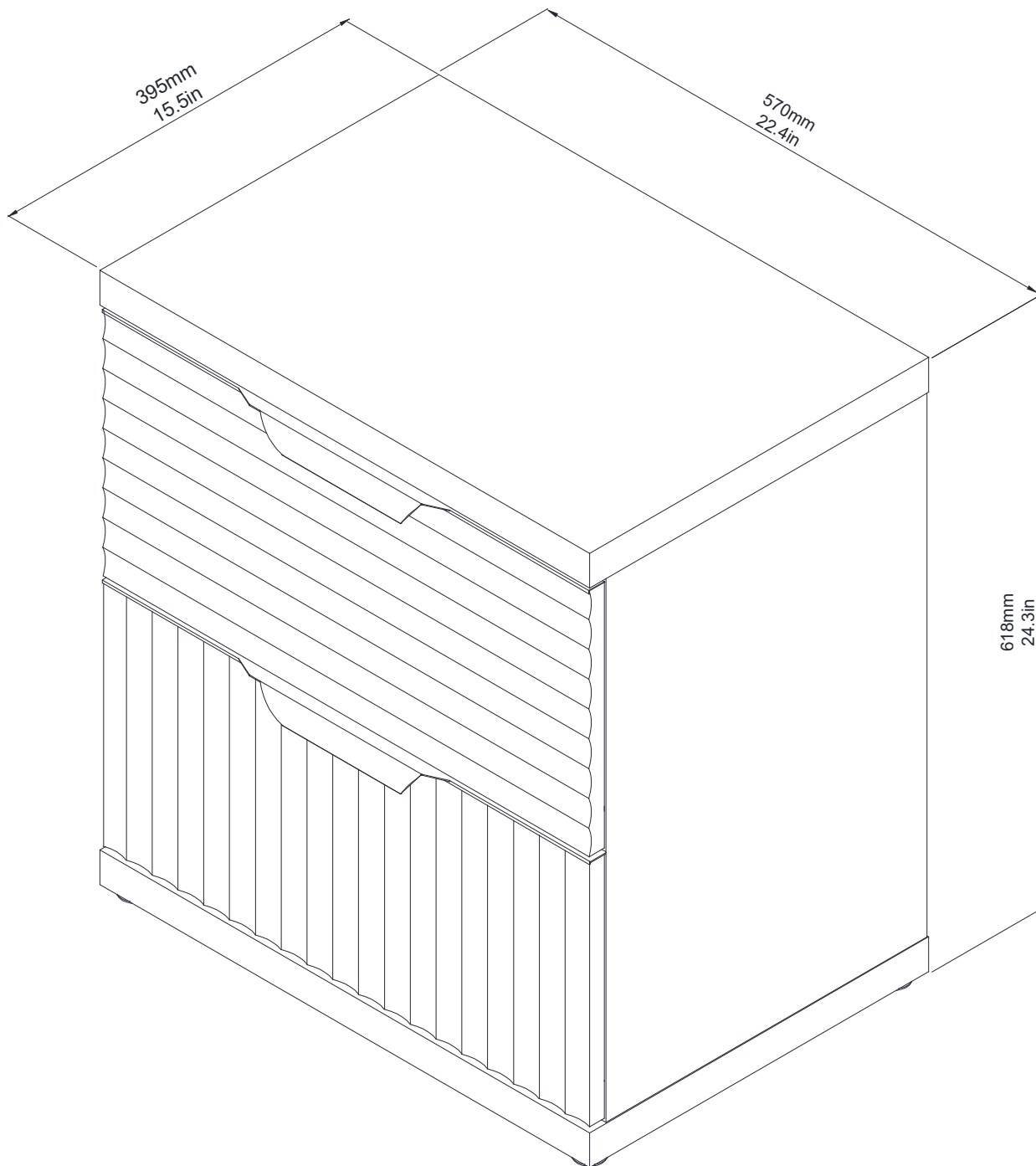

Final assmebly