

# ASSEMBLY INSTRUCTIONS

## X-BACK SIDE CHAIR

*Reading struction carefully priorto assembly*





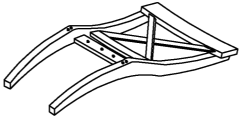
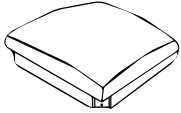
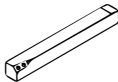

*Thank you for purchasing this quality product. Check carefully for small parts which may have come loose during shipment.*

*Remove all components from pack and place table top upside down on softsurface such as carpet or clothto prevent scratching the finish. Identify and count all parts as specified below. Do not tighten bolts until assembly is complete.*

### "PART LISTS"

STT	DESC	OUTLOOK	Q'TY
1	CHAIR BACK		1pc
2	SEAT FRAME		1pc
3	CHAIR LEGS		2pc

### "HARDWARE LISTS"

STT	OUTLOOK	SIZE	Q'TY
A		5/16" x 3" BOLT	4pcs
B		5/16"x2 " BOLT	4pcs
C		5/16"x1 1/2" BOLT	2pcs
D		5/16" SPRING WASHER	10pcs
E		5/16"x19mm LOCK WASHER	10pcs
F		4mm ALLEN WRENCH	1pc

STEP 1

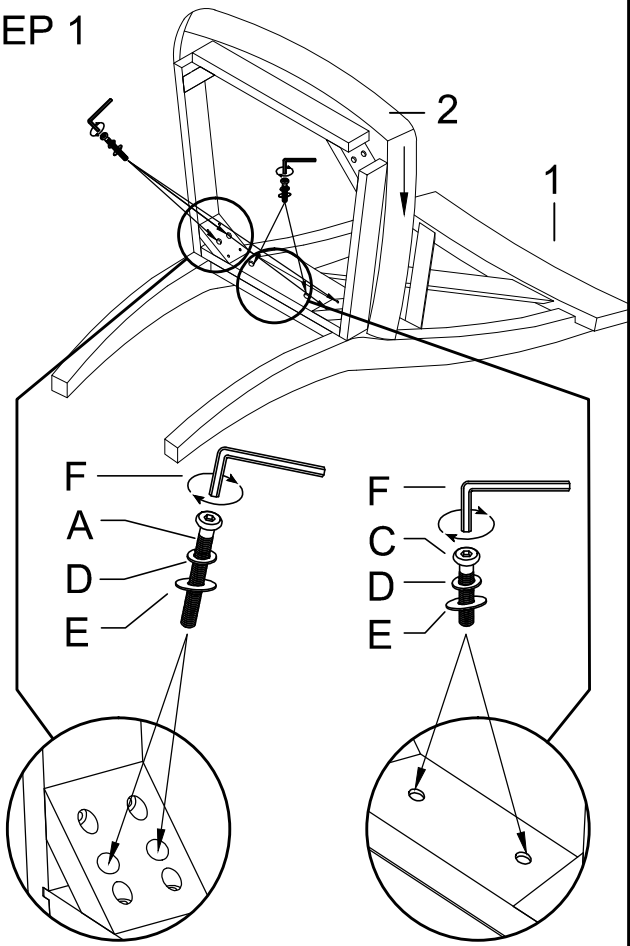

STEP 2

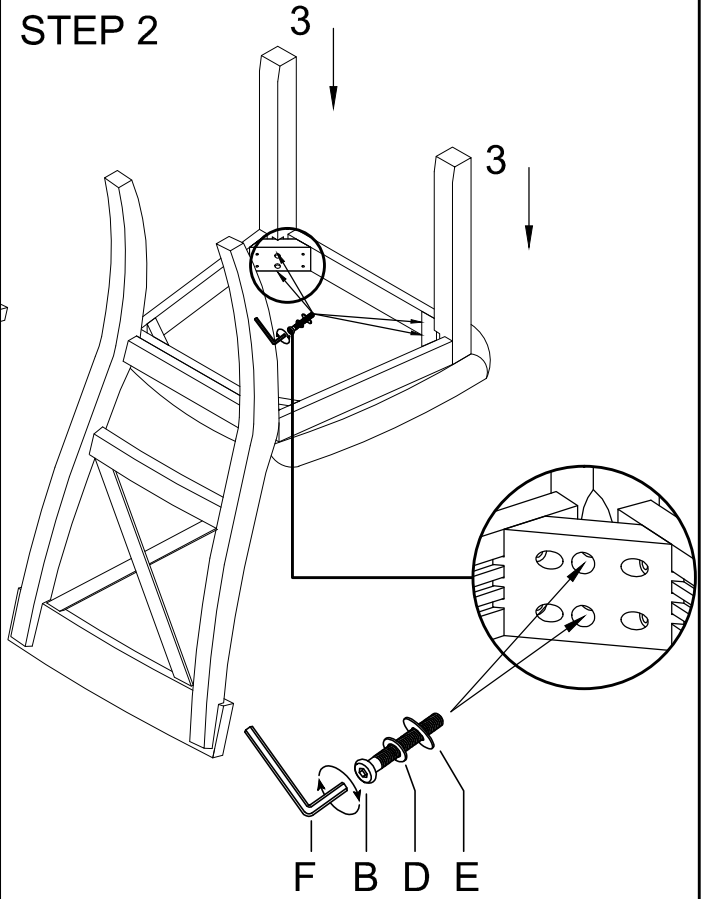

FINAL

