

**VERTICAL DESKTOP SORTER  
ASSEMBLY MANUAL**

**THANK YOU FOR SELECTING THE VERTICAL DESKTOP SORTER!** This product is perfect for the busy office worker - it is a compact, desktop organizer that can hold numerous documents, letters, and memos. The sorter includes 10 hardboard shelves that form up to 11 letter-sized compartments. The entire unit can support up to 15 lbs. Shelves can also be removed to create larger compartments for document bundles. The vertical desktop sorter is constructed of compressed wood with a laminate finish and has a solid hardboard back. This guide will help you assemble your sorter.

## NOTES

- Do not store liquids inside the compartments.
- Designed for inside use only.
- Never stand on the sorter as it was not designed to hold your weight.

## BEFORE YOU ASSEMBLE

- Place all parts on a clean, smooth surface to avoid scratching the parts.
- Check to be sure you have all parts and hardware.
- Remove all wrapping materials, including any staples & packing straps.
- Keep all hardware, small parts and packaging out of reach of children.

## SPECIFICATIONS

width: 10-<sup>3</sup>/<sub>4</sub> inches (27.3cm)

depth: 12 inches (30.5cm)

height 16 inches (40.6)

color: wood

construction: furniture-grade particle board

number of compartments: 11

## PARTS

Check your package and your carton should contain all items shown in the parts list below - if not, consult the retailer who sold you the product.

1 Top Panel (A)

1 Bottom Panel (B)

1 Side Panel (C)

1 Side Panel (D)

1 Back Panel (E)

10 Shelves (F)

40 Shelf Supports (G)

10 Nails (H)

12 Dowels (I)

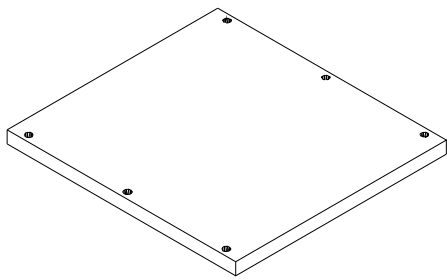

**1 Top Panel (A)**

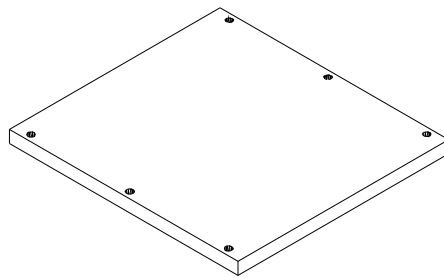

**1 Bottom Panel (B)**

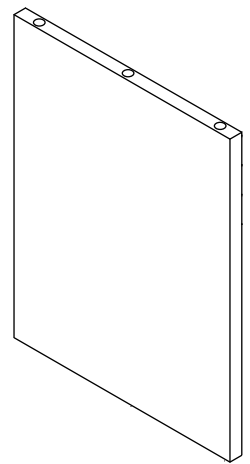

**1 Side Panel (C)**

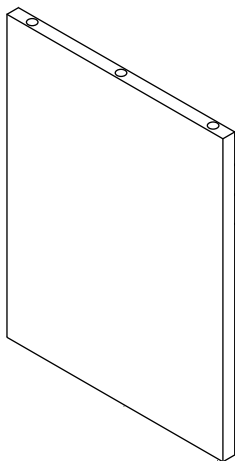

**1 Side Panel (D)**

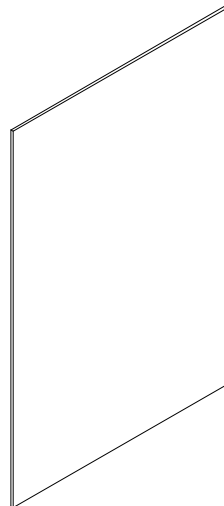

**1 Back Panel (E)**

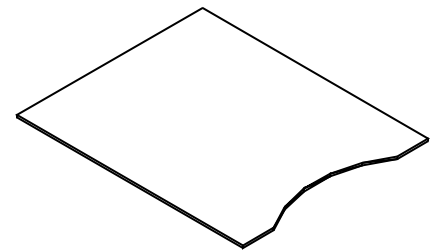

**10 Shelves (F)**



**40 Shelf Supports (G)**

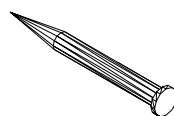

**10 Nails (H)**

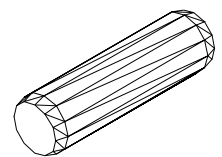

**12 Dowels (I)**

# ASSEMBLY INSTRUCTIONS

## STEP 1

- 1.) Lay top panel A and bottom panel B on a flat surface with holes facing up.
- 2.) Insert a small amount of glue in each hole.
- 3.) Carefully insert dowels I into holes (softly tap with a mallet if needed).

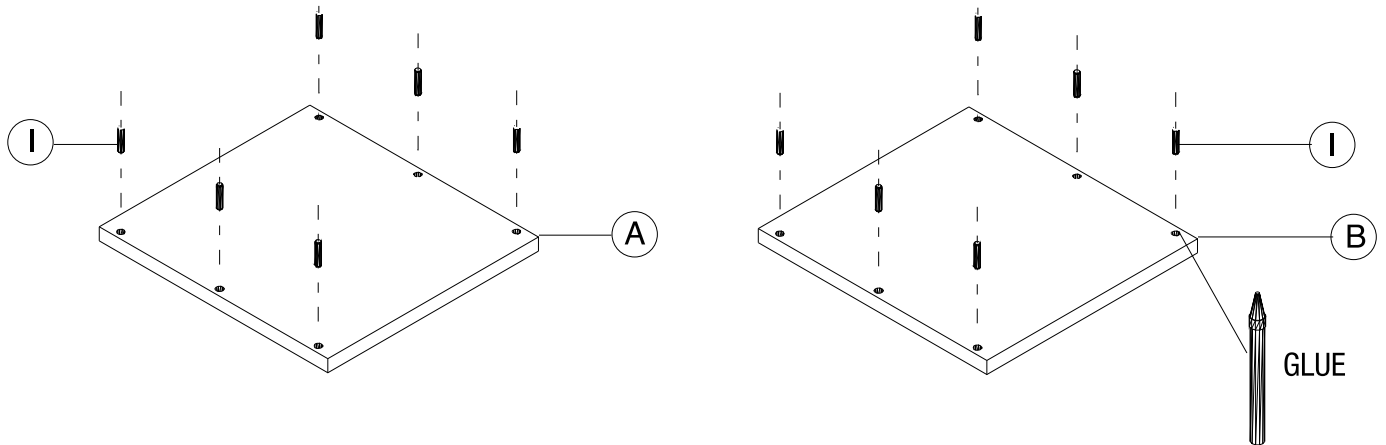

## STEP 2

- 1.) Insert a small amount of glue in each hole on the edges of side panels C and D.
- 2.) Align dowels on top and bottom panels A and B with holes on side panels C and D.
- 3.) Carefully press top and bottom panels A and B together with side panels C and D (softly tap with a mallet if needed).

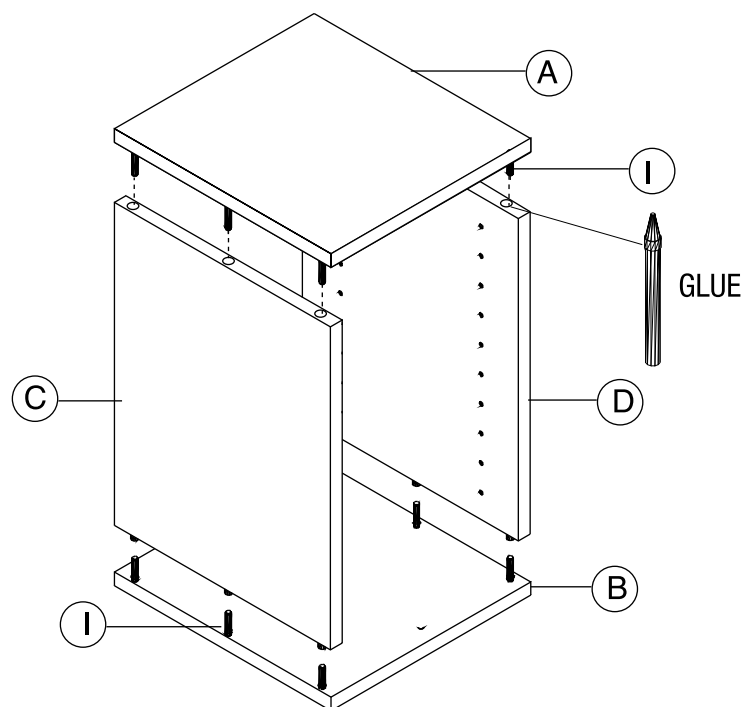

## STEP 3

- 1.) Align back panel E with the unfinished side of the panels.
- 2.) Using a hammer, install nails H through back panel E and into side panels.

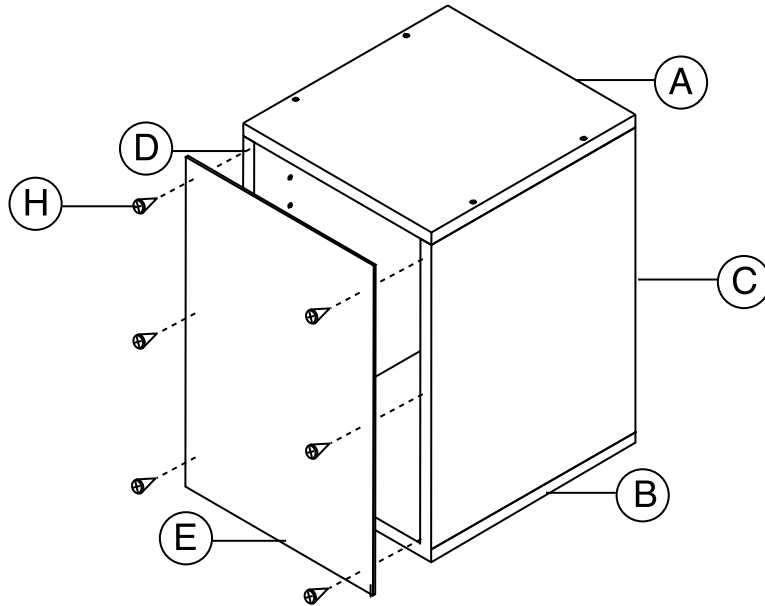

## STEP 4

- 1.) Install shelf supports G into holes on the insides of side panels C and D.

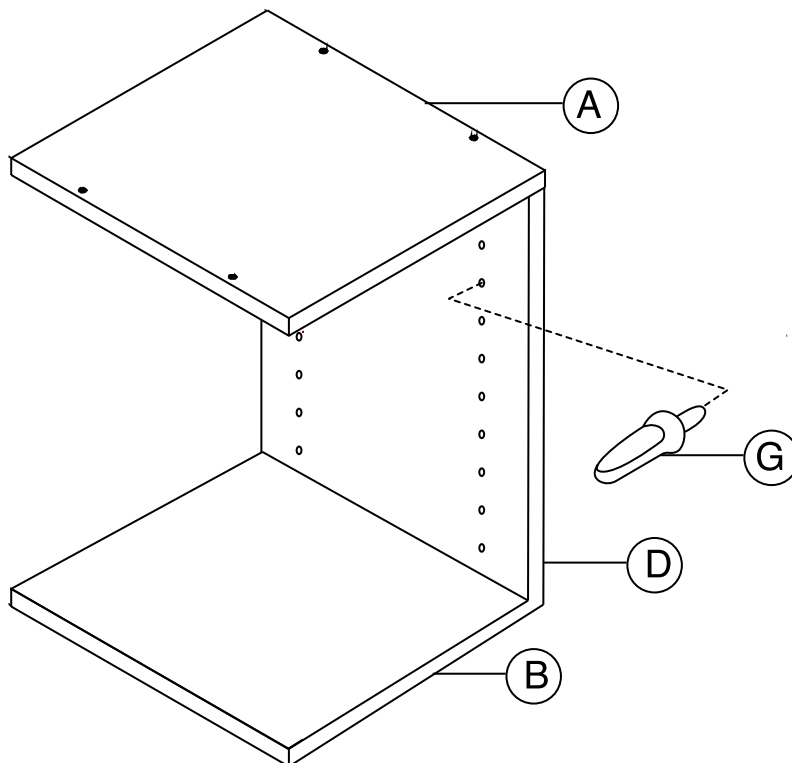

## STEP 5

1.) Carefully insert shelving F on top of supports G (be sure they are level).

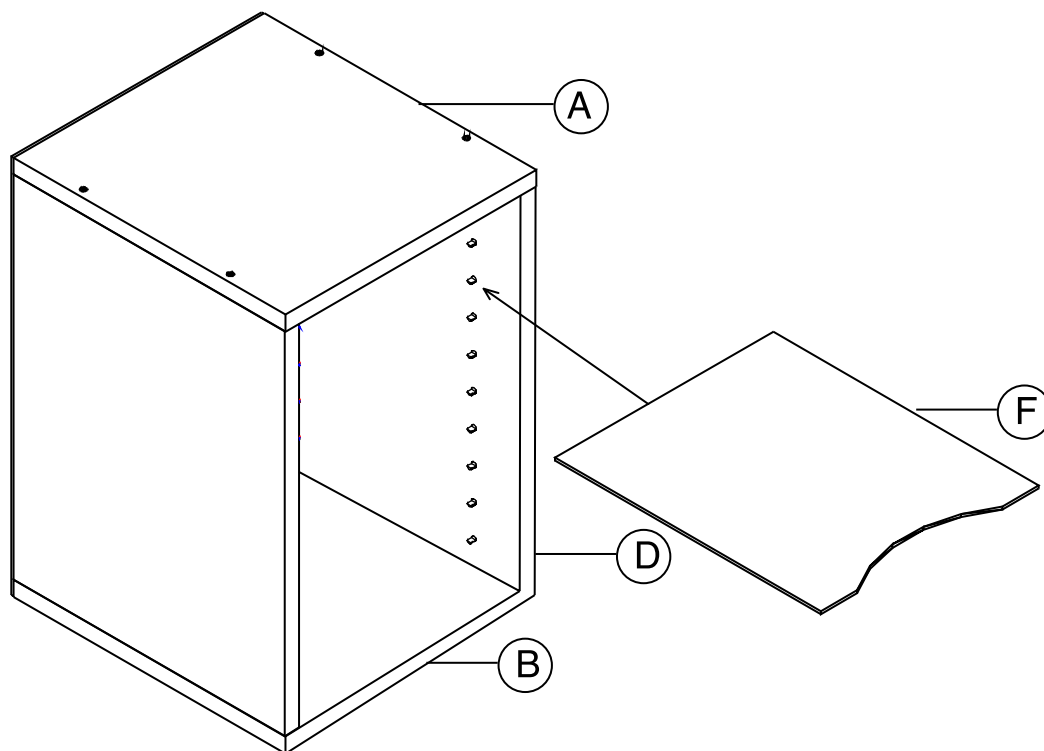

# LIMITED WARRANTY

1. The Adir Company (the company) warrants to the purchaser that the product will be free from defects in workmanship and materials for a period of one (1) year from the date of purchase.
2. These warranties are not assignable or transferable to any other person.
3. Any damage to the product as a result of misuse, tampering, abuse, neglect, accident, improper installation, modification, unauthorized service, destruction, or the alteration of the serial number, or use violate of the instructions furnished by the Company will void this warranty.
4. The sole responsibility of the Company shall be limited to the repair or replacement (in its sole discretion) of any component of the product which fails to conform to this warranty at no cost to the purchaser for the period of the warranty.
5. Contact the Company directly to obtain service under this warranty. If it becomes applicable to send a defective product to the Company, a Return Authorization Number must first be obtained from the company. In order to obtain service under this warranty, purchaser must provide the Company with the following items (a) proof of purchase, (b) police or fire department report, (c) photographs of damaged sad, and (d) written testimonial.
6. Products shipped without prior Return Authorization and Return Authorization Number may not be accepted, and the Company will not be responsible for their disposition and/or cost of return to the owner.
7. The Company will not assume any responsibility for any loss or damage incurred in shipping. All return authorized products should include a copy of the original invoice in order that this warranty may be Honored.
8. This warranty is not an insurance policy. The Company is not responsible for any manner of damage to or theft of the Purchaser's product or its contents.
9. We recommend that the enclosed warranty card be completed in full, and returned to the Company within ten (10) days of the original date of purchase to validate this warranty.
10. Any implied warranties that the purchaser may have are limited to the duration of the warranties described above. There are no further warranties that extend or apply beyond the face hereof, and the company expressly disclaims and excludes any and all warranties of merchantability or fitness for a particular purpose. Some states do not allow limitations on how long an implied warranty lasts, so the above limitation may not apply to you.
11. Repair or replacement shall be the sole remedy for the purchaser under this warranty. The company shall not be liable for any direct, indirect, incidental or consequential damages, losses or expense arising from the use or misuse of the product. Some states do not allow the exclusion or limitations of incidental or consequential damages, so the limitation may not apply to you.
12. This warranty gives you specific legal rights, and you may also have other rights which vary from state to state.

# DISCLAIMER

ADIRoffice. does not guarantee that our products will absolutely stop theft, vandalism, burglary, or acts of God. Our products are only a DETERRENT to such acts.

ADIRoffice will always do its utmost to stay current on the prevention of theft and burglary and will continue to offer the best products possible to help in the prevention of such crimes.

By purchasing products from ADIRoffice, user agrees as follows:

TO THE MAXIMUM EXTENT PERMITTED BY LAW, THE PRODUCTS AND INFORMATION ON THIS SITE IS PROVIDED "AS IS" AND WITH ALL FAULTS AND ADIRoffice. MAKES NO PROMISES, REPRESENTATIONS, OR WARRANTIES, EITHER EXPRESS, IMPLIED, STATUTORY, OR OTHERWISE, WITH RESPECT TO THE PRODUCTS AND INFORMATION, INCLUDING ITS CONDITION, ITS CONFORMITY TO ANY REPRESENTATION OR DESCRIPTION, OR THE EXISTENCE OF ANY LATENT OR PATENT DEFECTS, AND ADIRoffice. SPECIFICALLY DISCLAIMS ALL IMPLIED (IF ANY) WARRANTIES OF TITLE, MERCHANTABILITY, NONINFRINGEMENT, FITNESS FOR A PARTICULAR PURPOSE, ACCURACY OR COMPLETENESS, QUIET ENJOYMENT, AND QUIET POSSESSION. THE ENTIRE RISK ARISING OUT OF USE OR PERFORMANCE OF THE PRODUCTS AND INFORMATION LIES WITH USER.

TO THE MAXIMUM EXTENT PERMITTED BY LAW, IN NO EVENT SHALL ADIRoffice PRODUCTS OR ITS SUPPLIERS BE LIABLE FOR CONSEQUENTIAL, INCIDENTAL, SPECIAL, INDIRECT, OR EXEMPLARY DAMAGES WHATSOEVER ARISING OUT OF OR IN ANY WAY RELATING TO THIS AGREEMENT OR USER'S USE OF OR INABILITY TO USE THE PRODUCTS AND INFORMATION, OR THE PROVISION OR FAILURE TO PROVIDE SUPPORT SERVICES, INCLUDING, BUT NOT LIMITED TO, LOST PROFITS, LOSS OF CONFIDENTIAL OR OTHER INFORMATION, BUSINESS INTERRUPTION, PERSONAL INJURY, LOSS OF PRIVACY, FAILURE TO MEET ANY DUTY (INCLUDING OF GOOD FAITH OR REASONABLE CARE), NEGLIGENCE, COSTS OF PROCUREMENT OF SUBSTITUTE GOODS OR SERVICES, OR ANY OTHER CLAIM FOR PECUNIARY OR OTHER LOSS WHATSOEVER, OR FOR ANY CLAIM OR DEMAND AGAINST USER BY ANY OTHER PARTY, EVEN IF ADIRoffice HAS BEEN ADVISED OF THE POSSIBILITY OF SUCH DAMAGES. THESE LIMITATIONS SHALL APPLY NOTWITHSTANDING ANY FAILURE OF ESSENTIAL PURPOSE OF ANY LIMITED REMEDY.

NOTWITHSTANDING ANY DAMAGES USER MAY INCUR FOR ANY REASON WHATSOEVER (INCLUDING, WITHOUT LIMITATION, ALL DAMAGES REFERENCED ABOVE AND ALL DIRECT OR GENERAL DAMAGES), THE ENTIRE LIABILITY OF ADIRoffice AND ANY OF ITS SUPPLIERS UNDER ANY PROVISION OF THIS AGREEMENT AND YOUR EXCLUSIVE REMEDY FOR ALL OF THE FOREGOING SHALL BE LIMITED TO THE GREATER OF THE AMOUNT ACTUALLY PAID FOR THE PRODUCTS AND INFORMATION OR U.S. \$1. THE FOREGOING LIMITATIONS, EXCLUSIONS, AND DISCLAIMERS SHALL APPLY TO THE MAXIMUM EXTENT PERMITTED BY APPLICABLE LAW, EVEN IF ANY REMEDY FAILS ITS ESSENTIAL PURPOSE.

If any provision of this Agreement is declared invalid or unenforceable, the remaining provisions of this Agreement will remain in effect. ADIRoffice has the right to modify these terms and conditions at any time.



follow us on

