



Instruction Manual

VERSION:01



- Important, retain for future reference: read carefully
- Wichtig, für spätere nachschlage aufbewahren: sorgfältig lesen
- Importante, guardar para referencia futura: leer atentamente
- Importante, conservare per riferimenti futuri: leggere attentamente
- Important, à conserver pour référence future : lire attentivement

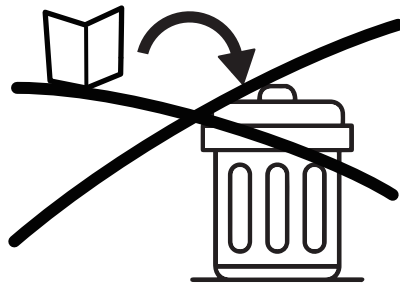
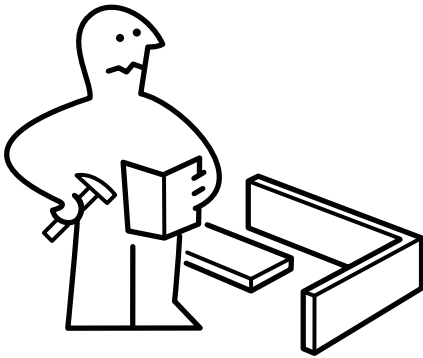

- Assemble on a flat, clean and soft surface.
- Auf einer flachen, sauberen und weichen Oberfläche zusammenbauen.
- Assembler sur une surface plate, propre et douce.
- Assemblare su una superficie piatta, pulita e morbida.
- Ensamblar sobre una superficie plana, limpia y suave.

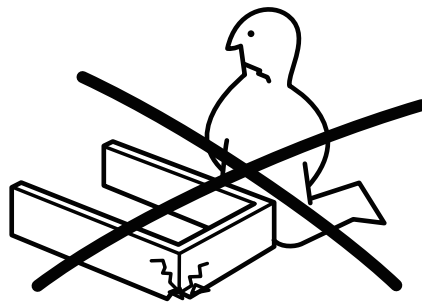
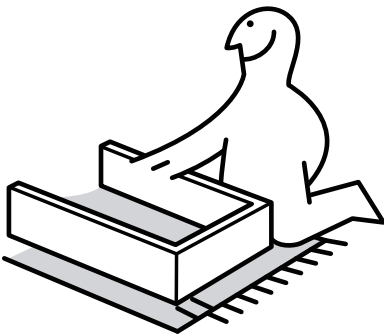

- Professional installation is highly recommended.
- Eine professionelle Installation wird dringend empfohlen.
- Une installation professionnelle est fortement recommandée.
- Si raccomanda vivamente l'installazione professionale.
- Se recomienda altamente la instalación profesional.



- Periodically check that all components are tightly secured.
- Überprüfen sie regelmäßig, dass alle Komponenten fest gesichert sind.
- Vérifiez périodiquement que tous les composants sont bien fixés.
- Controllare periodicamente che tutti i componenti siano ben fissati.
- Verifique periódicamente que todos los componentes estén bien asegurados.



- It is recommended that multiple people assemble this product.
- Es wird empfohlen, dass mehrere Personen dieses Produkt zusammenbauen.
- Il est recommandé que plusieurs personnes assemblent ce produit.
- Si raccomanda che più persone assemblino questo prodotto.
- Se recomienda que varias personas ensamblen este producto.

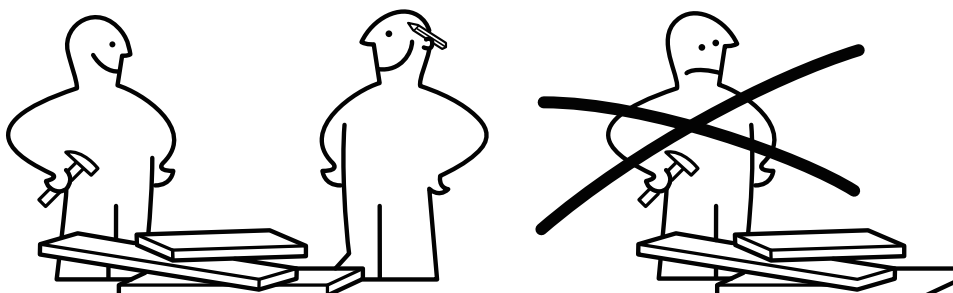

- Please have the following auxiliary tools ready:
- Bitte haben Sie die folgenden Hilfswerkzeuge bereit:
- Veuillez avoir les outils auxiliaires suivants à portée de main:
- Si prega di avere pronti i seguenti strumenti ausiliari:
- Por favor, tenga listos las siguientes herramientas auxiliares:

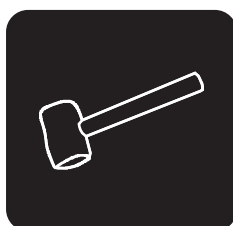
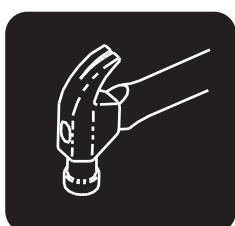

- Serious or fatal crushing injuries can occur due to furniture tip-over. Always secure this furniture to the wall with tip-over restraints.
- Schwere oder tödliche Quetschverletzungen können durch das Umkippen von Möbeln verursacht werden. Sichern Sie diese Möbel immer mit Kipp-Sicherungen an der Wand.
- Des blessures graves ou mortelles par écrasement peuvent survenir lors du basculement de meubles. Fixez toujours ces meubles au mur avec des dispositifs anti-basculement.
- Lesioni gravi o mortali da schiacciamento possono verificarsi a causa del ribaltamento dei mobili. Fissare sempre questi mobili alla parete con i sistemi antiribaltamento.
- Pueden ocurrir lesiones graves o fatales por aplastamiento por el volcamiento de muebles. Asegure siempre este mueble a la pared con dispositivos anti-vuelco.

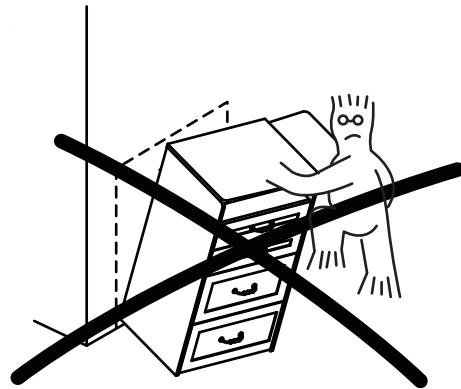
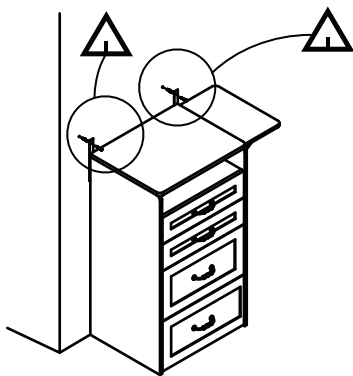

- Never let children climb or hang on drawers, doors, or shelves.
- Lassen Sie Kinder niemals auf Schubladen, Türen oder Regalen klettern oder hängen.
- Ne laissez jamais les enfants grimper ou se suspendre aux tiroirs, portes ou étagères.
- Non permettere mai ai bambini di arrampicarsi o appendersi ai cassetti, alle porte o agli scaffali.
- Nunca permita que los niños trepen o se cuelguen de los cajones, puertas o estantes.



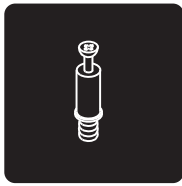

Cam bolt
Exzenterbolzen
Boulon à came
Bullone a camma
Perno de leva

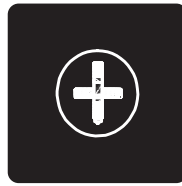

Connecting piece
Verbindungsstück
Pièce de connexion
Raccordo di collegamento
Pieza de conexión

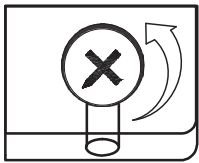

Rotate connecting piece if found in the position illustrated above.
Verbinderstück drehen, falls in der oben abgebildeten Position.
Faire pivoter la pièce de connexion si elle se trouve dans la position illustrée ci-dessus.
Ruotare il raccordo se si trova nella posizione illustrata sopra.
Gire la pieza de conexión si se encuentra en la posición ilustrada arriba.

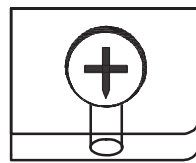

Correct orientation to receive bolts.
Richtige Ausrichtung für die Aufnahme der Bolzen.
Orientation correcte pour recevoir les boulons.
Orientamento corretto per ricevere i bulloni.
Orientación correcta para recibir los pernos.

Pin
Stift
Goupille
Perno
Pasador

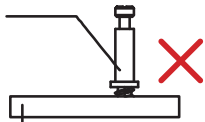



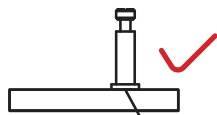



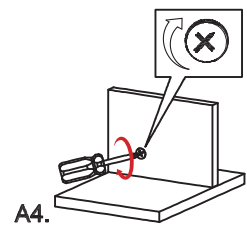
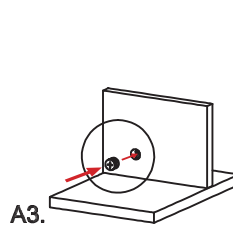
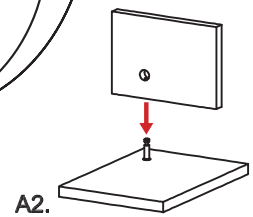
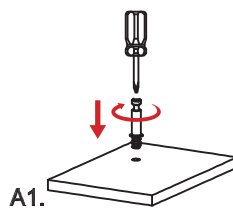



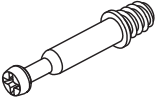

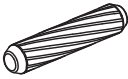
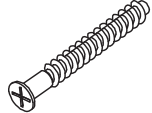

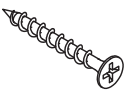
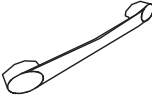



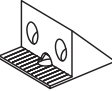
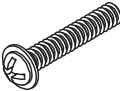

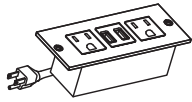
Panel
Platte
Panneau
Pannello
Panel

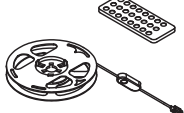

No gap
Kein Spalt
Pas d'espace
Nessuno spazio
Sin espacio

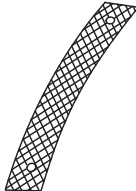
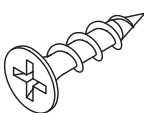
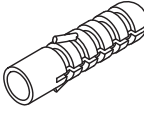
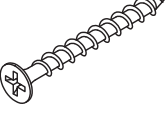

HARDWARE LIST

| | | | | |
|--|---|--|--|--|
| <p>A</p>  <p>6×35mm 70(+2)PCS</p> | <p>B</p>  <p>70(+2)PCS</p> | <p>C</p>  <p>6×30mm 24(+2)PCS</p> | <p>D</p>  <p>M5×40mm 8PCS</p> | <p>E</p>  <p>M3.5×12mm 26(+2)PCS</p> |
| <p>F</p>  <p>M3.5×35mm 8PCS</p> | <p>G</p>  <p>2PCS</p> | <p>H</p>  <p>M3×14mm 10(+1)PCS</p> | <p>J</p>  <p>M3×12mm 16(+1)PCS</p> | <p>K</p>  <p>2PCS</p> |
| <p>L</p>  <p>M4×12mm 2 PCS</p> | <p>M</p>  <p>10(+1) PCS</p> | <p>N</p>  <p>M4×16mm 4PCS</p> | <p>P</p>  <p>4 PCS</p> | <p>Q</p>  <p>1 PCS</p> |
| <p>R</p>  <p>M4×12mm 40(+2)PCS</p> | <p>S</p>  <p>1 PCS</p> | <p>T</p>  <p>8 PCS</p> | <p>U</p>  <p>M6×17mm 8 PCS</p> | <p>V</p>  <p>8 PCS</p> |
| <p>W</p>   <p>M3×15mm</p>   <p>M3×35mm</p> <p>2 PCS</p> | | | | |
|  <p>DL L250</p> <p>2PCS</p>  <p>DR L250</p> <p>2PCS</p>  <p>CL L250</p> <p>2PCS</p>  <p>CR L250</p> <p>2PCS</p> | | | | |

PANEL LIST

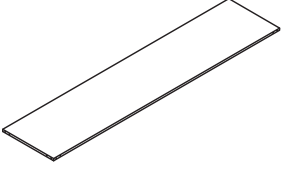
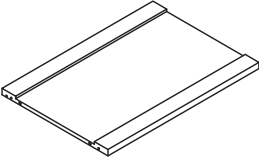
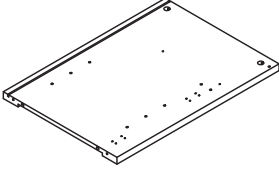
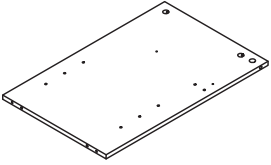
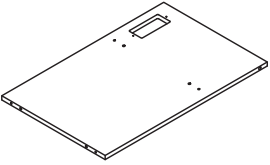
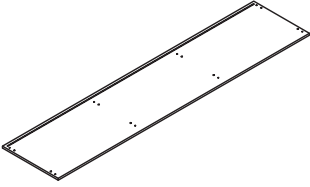
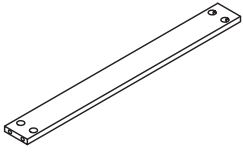
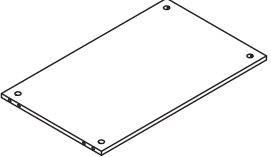
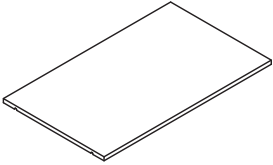
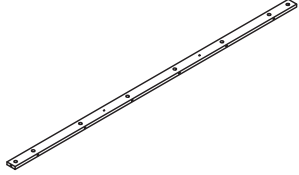
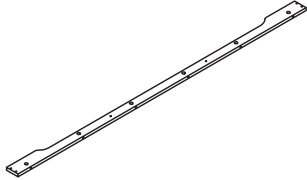
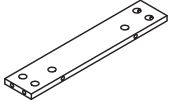
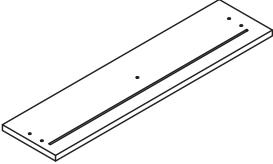
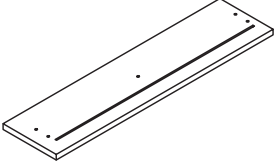
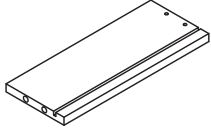
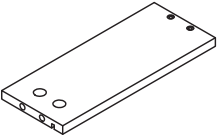
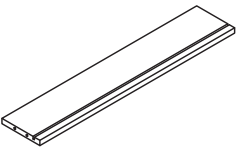
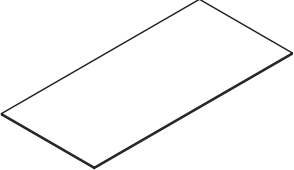
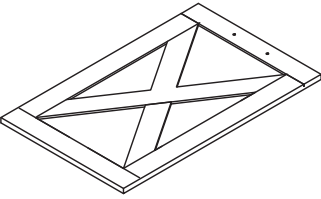
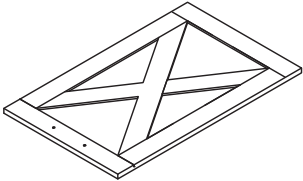
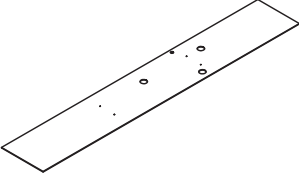
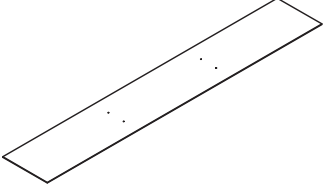
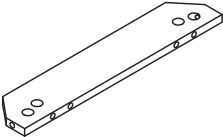
| | | | |
|--|--|---|--|
| <p>1</p>  <p>1780x400x15 1PCS</p> | <p>2</p>  <p>553x388x20 1PCS</p> | <p>3</p>  <p>553x388x20 1PCS</p> | <p>4</p>  <p>553x353x12 1PCS</p> |
| <p>5</p>  <p>553x353x12 1PCS</p> | <p>6</p>  <p>1760x390x12 1PCS</p> | <p>7</p>  <p>562x60x12 2PCS</p> | <p>8</p>  <p>570x345x12 1PCS</p> |
| <p>9</p>  <p>561x338x12 2PCS</p> | <p>10</p>  <p>1718x50x15 1PCS</p> | <p>11</p>  <p>1758x70x15 2PCS</p> | <p>12</p>  <p>358x70x12 2PCS</p> |
| <p>13</p>  <p>572x140x13 1PCS</p> | <p>14</p>  <p>572x140x13 1PCS</p> | <p>15</p>  <p>250x100x12 2PCS</p> | <p>16</p>  <p>250x100x12 2PCS</p> |
| <p>17</p>  <p>514x100x12 2PCS</p> | <p>18</p>  <p>522x245x3 2PCS</p> | <p>19</p>  <p>572x355x13 1PCS</p> | <p>20</p>  <p>572x355x13 1PCS</p> |
| <p>21</p>  <p>1726x280x3 1PCS</p> | <p>22</p>  <p>1726x280x3 1PCS</p> | <p>23</p>  <p>358x70x12 2PCS</p> | |

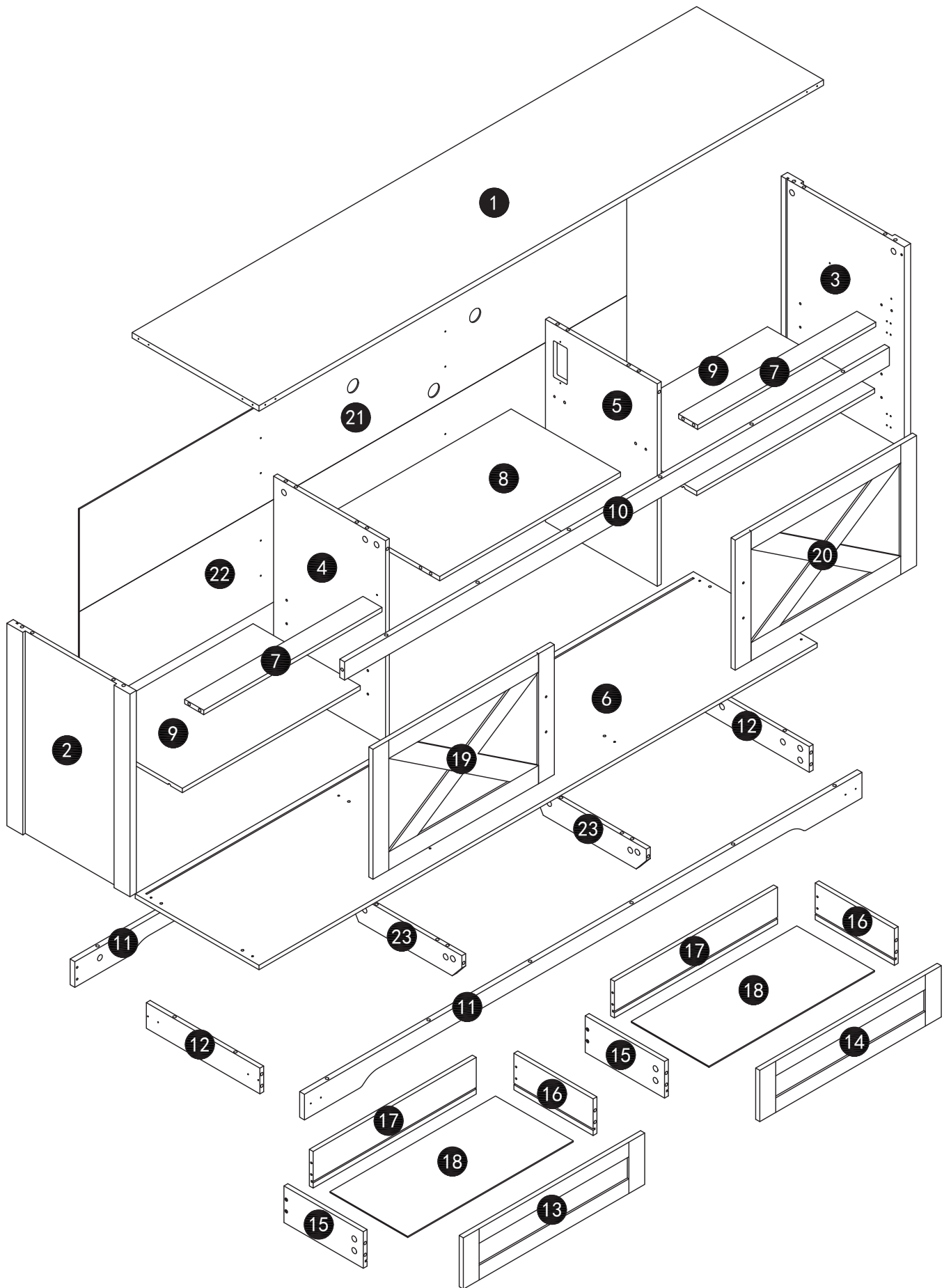

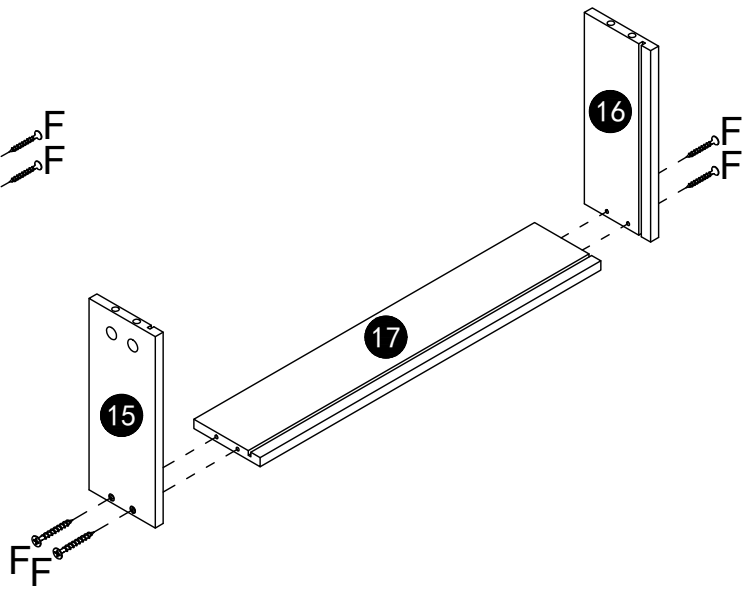
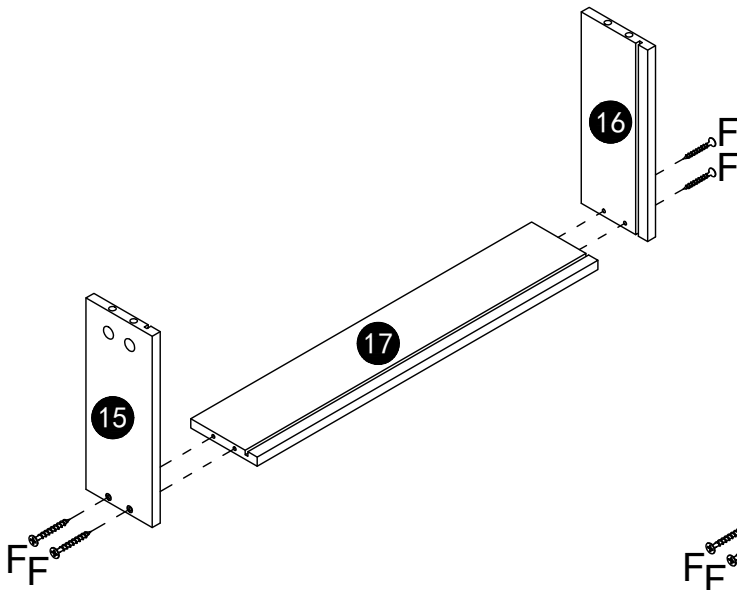
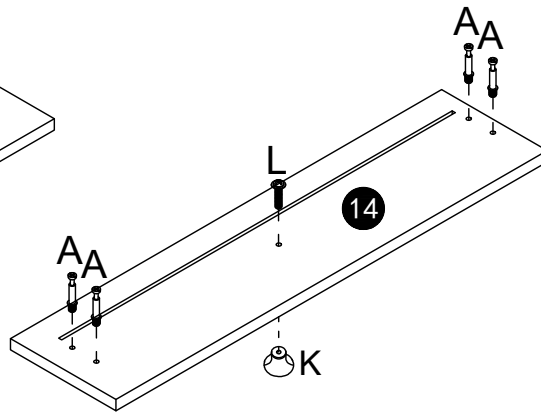
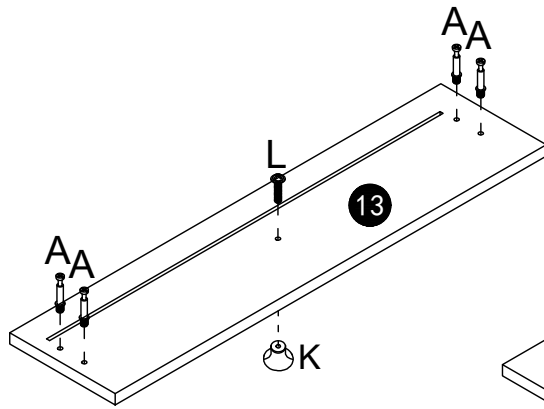
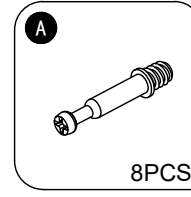
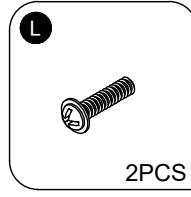
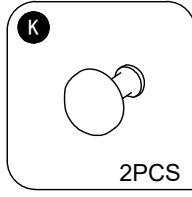
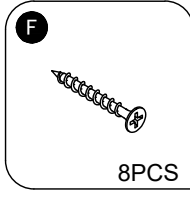
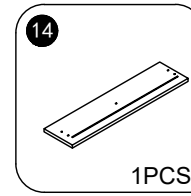
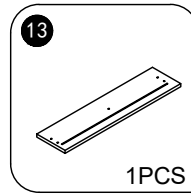
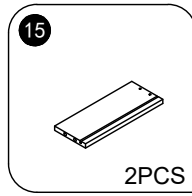
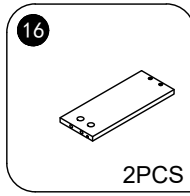
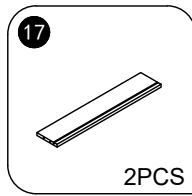

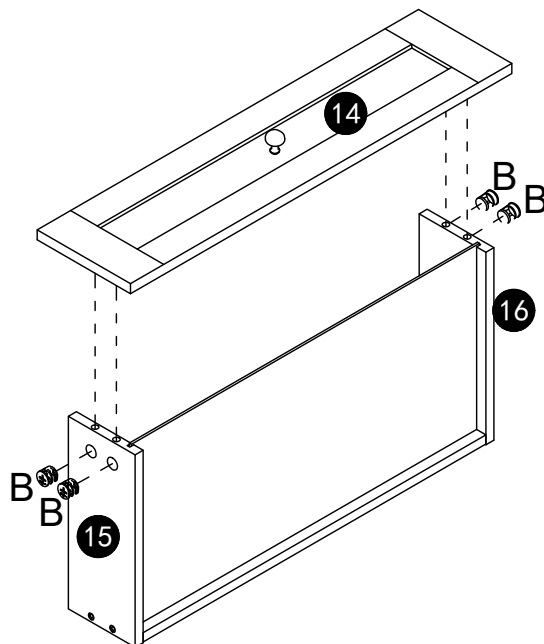
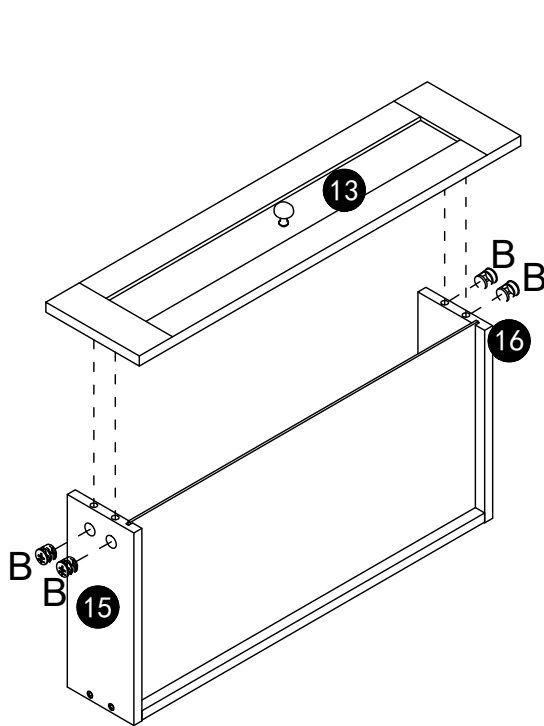
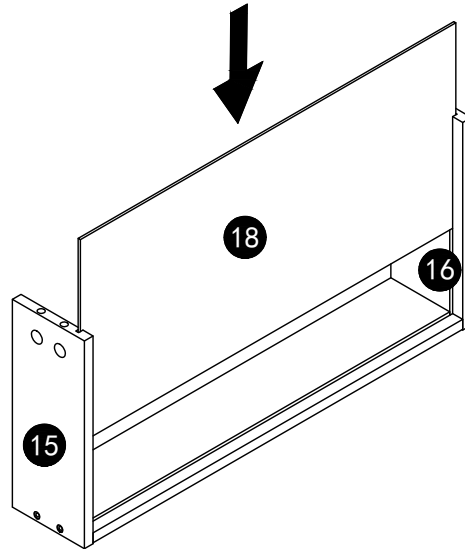
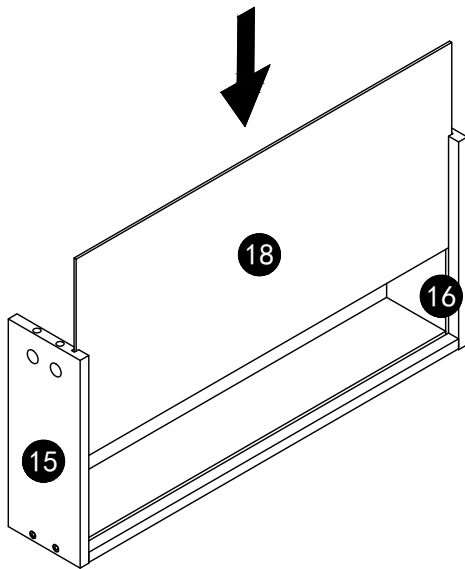
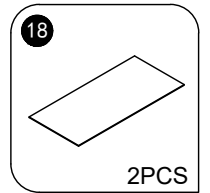
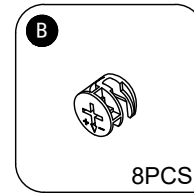

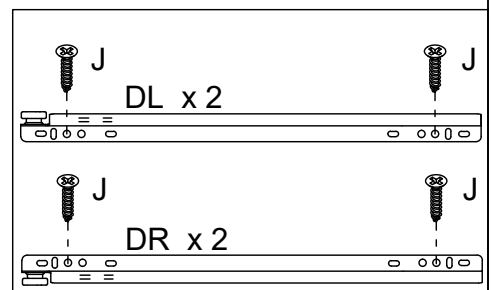
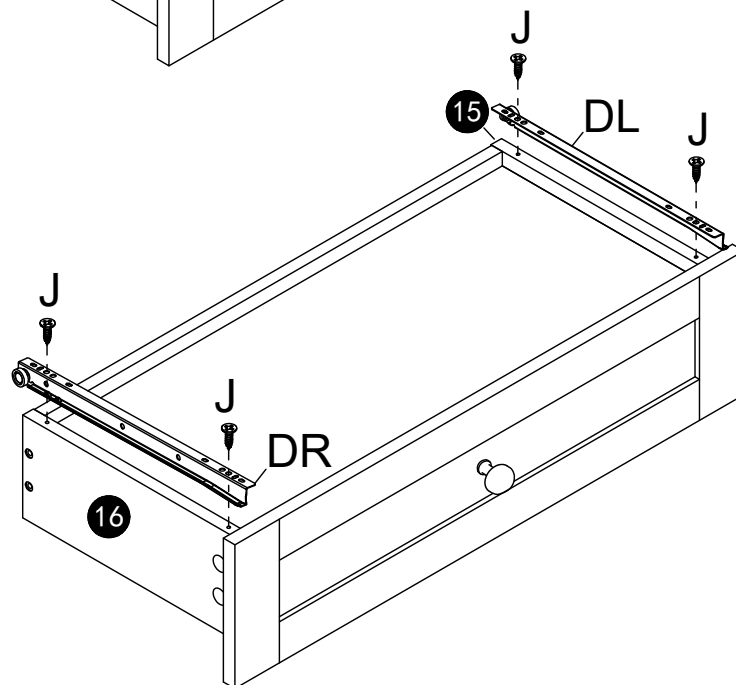
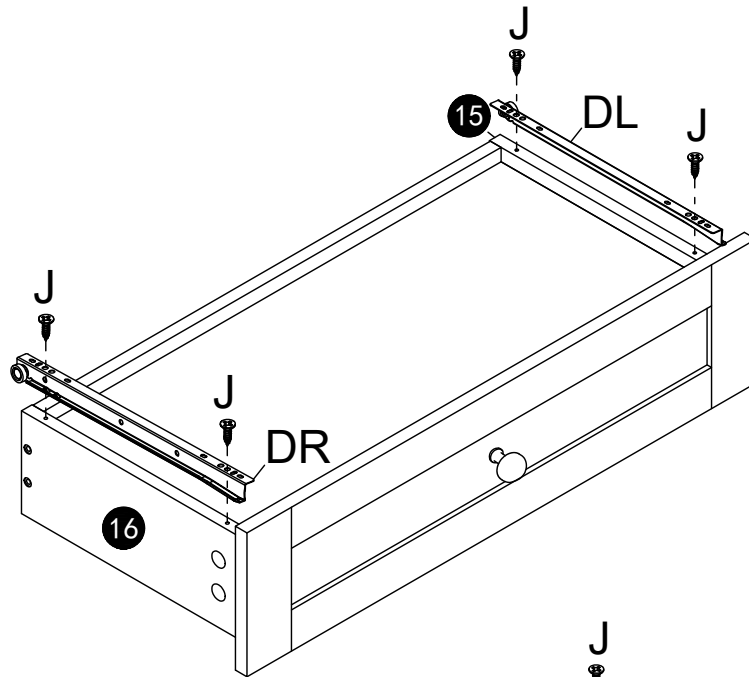
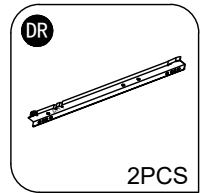
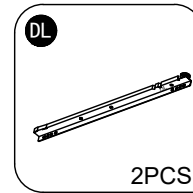
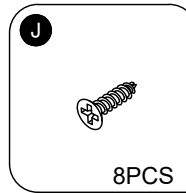

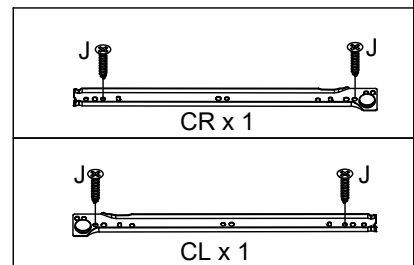
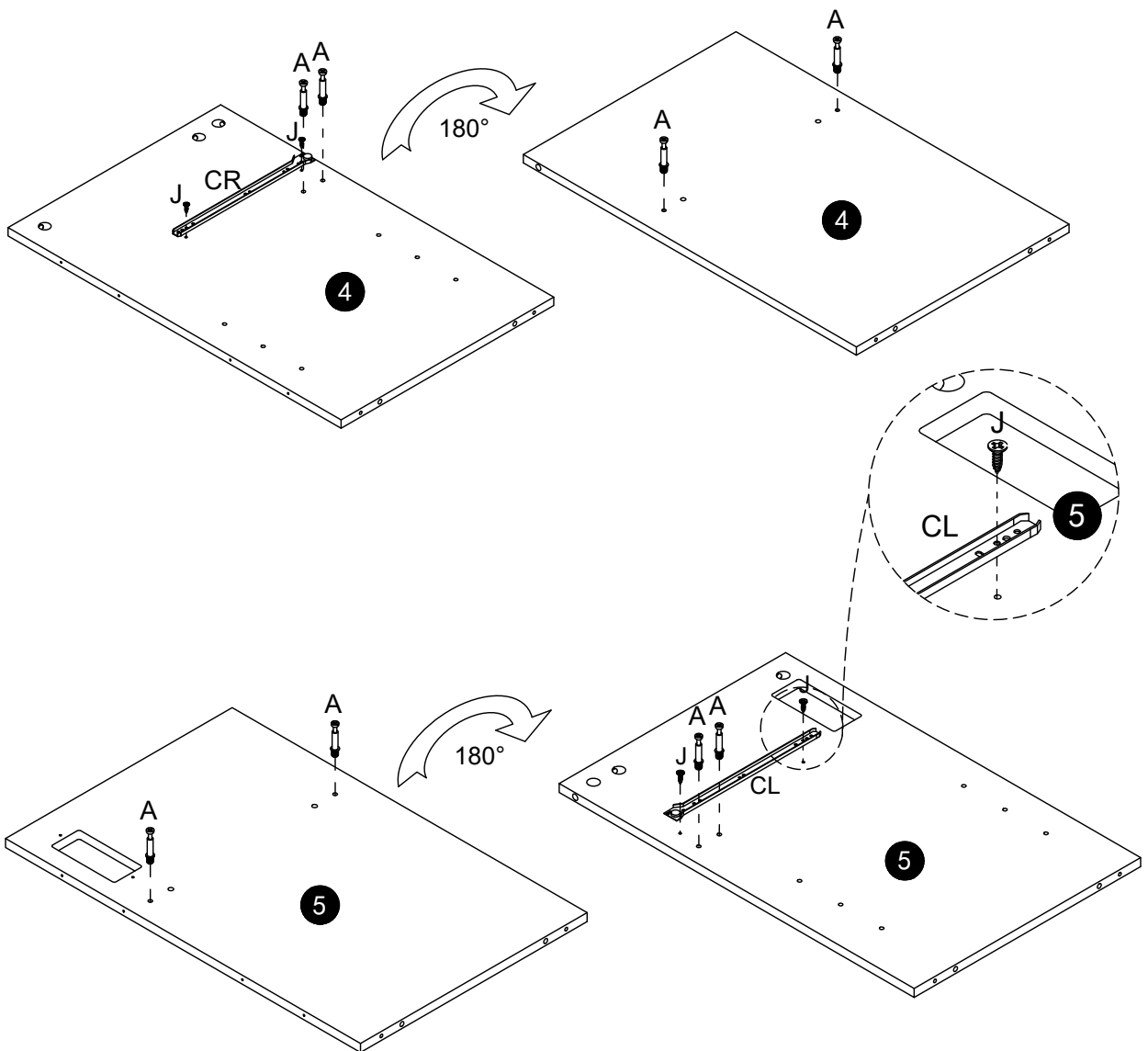
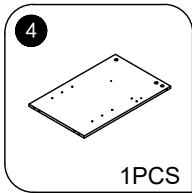
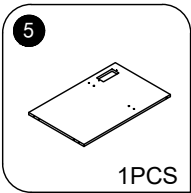
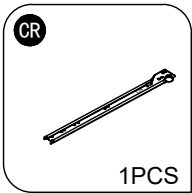
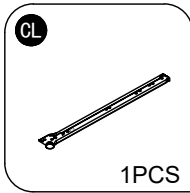
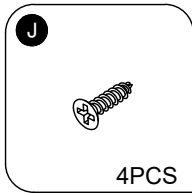
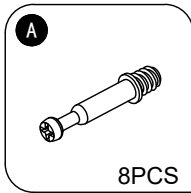

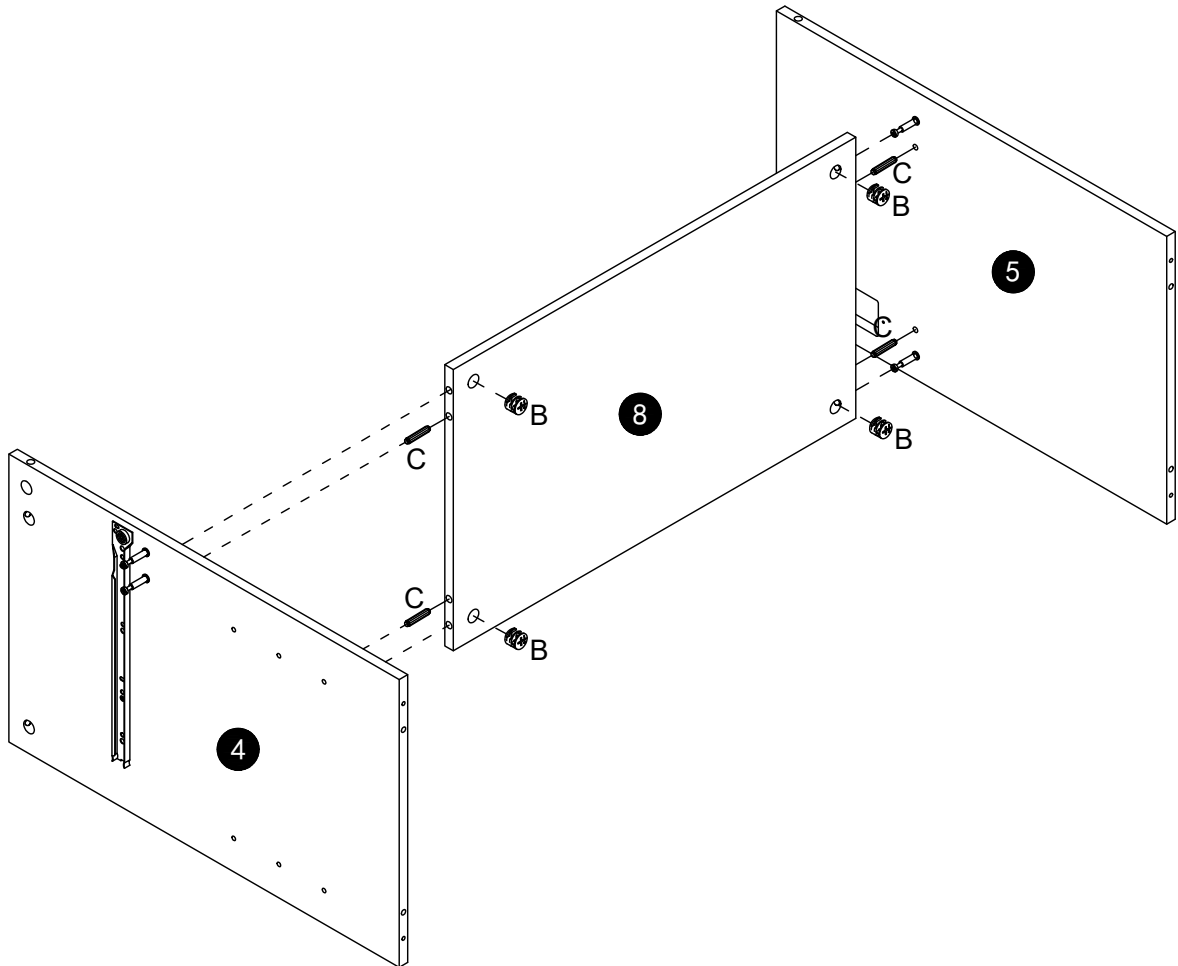
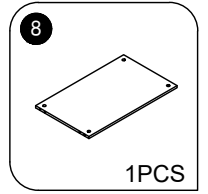
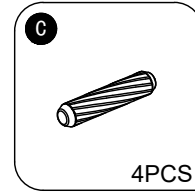
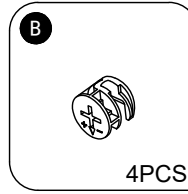

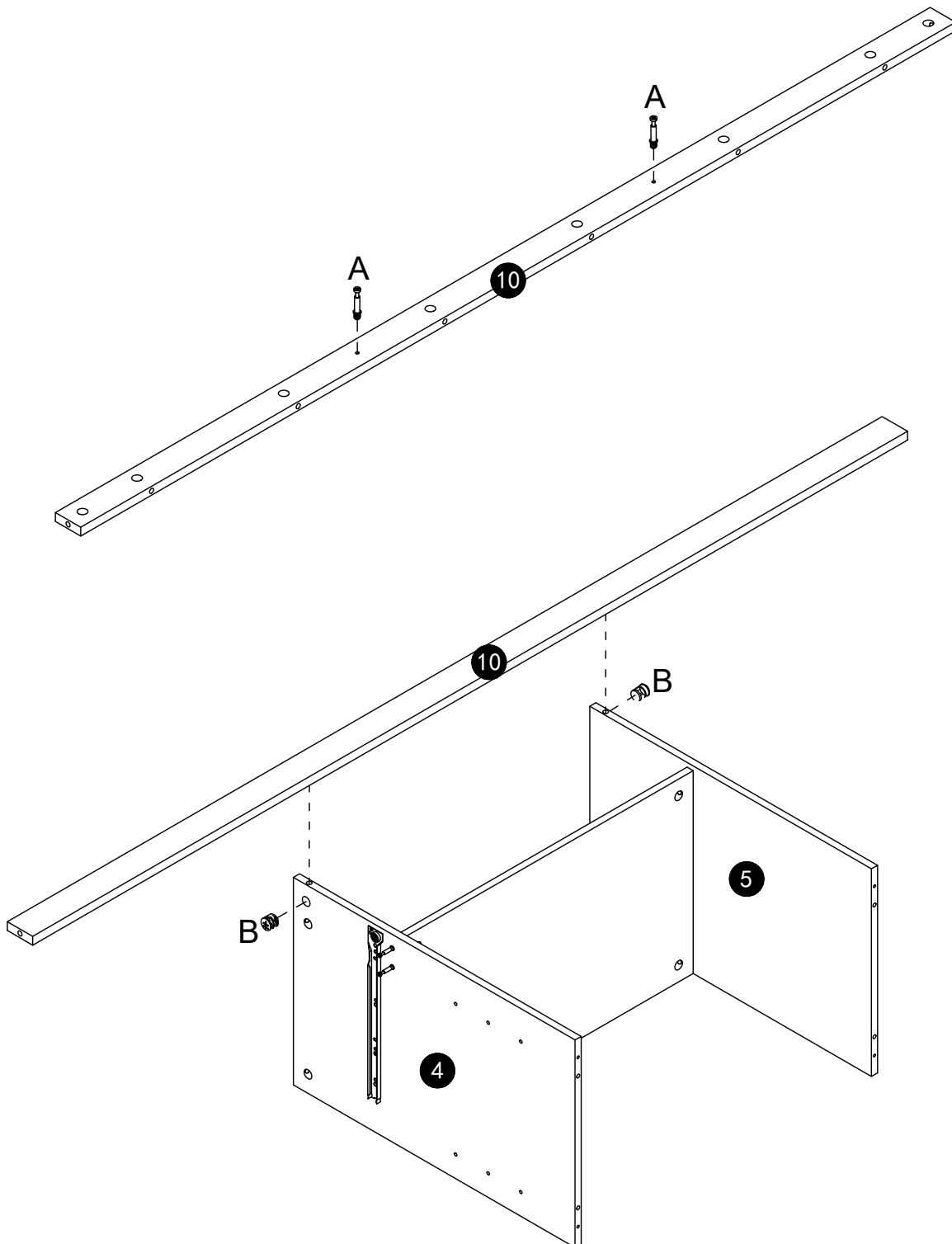
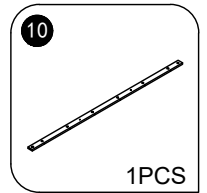
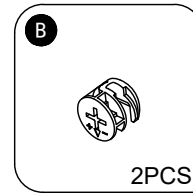
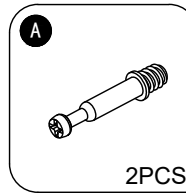

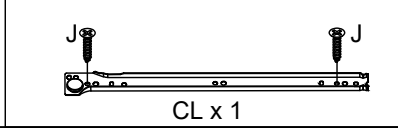
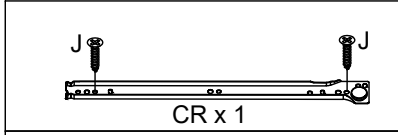
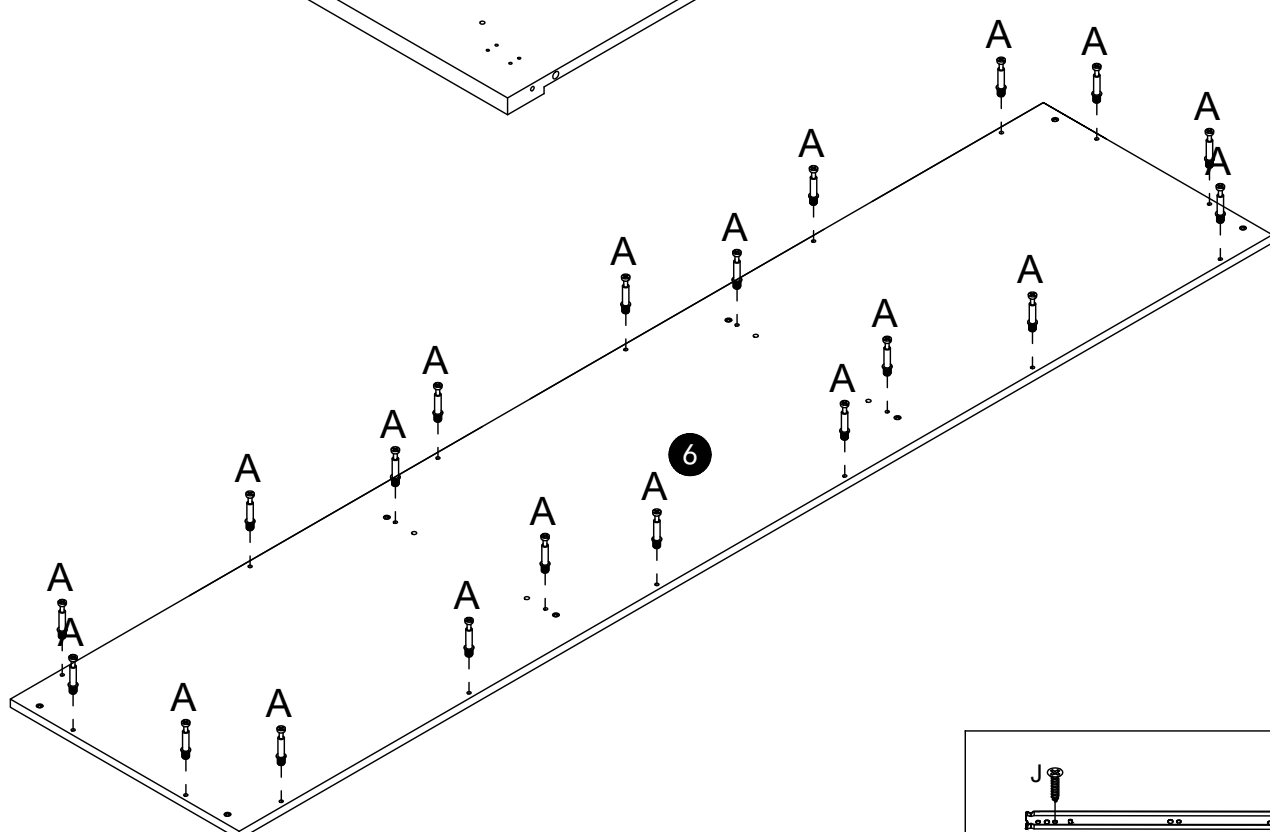
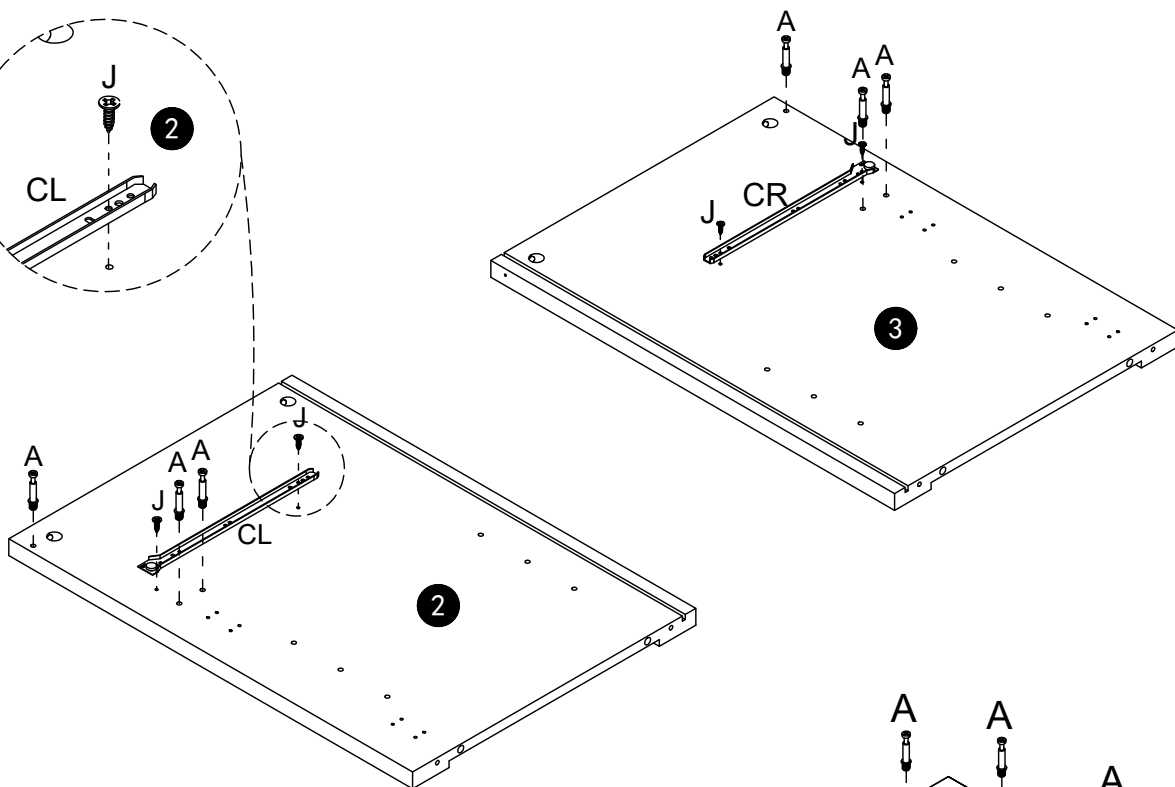
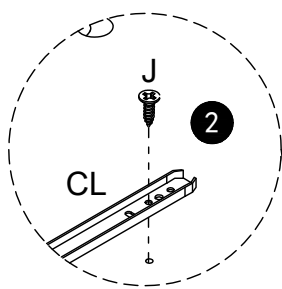
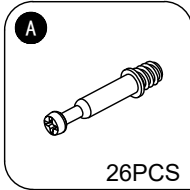
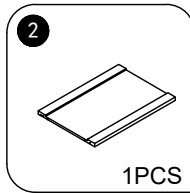
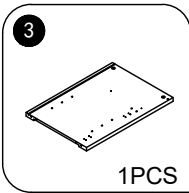
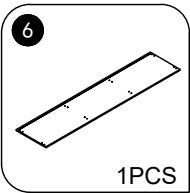
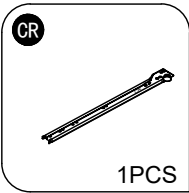
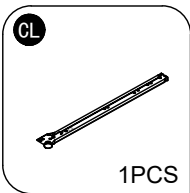
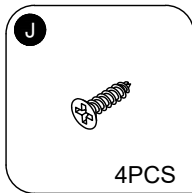

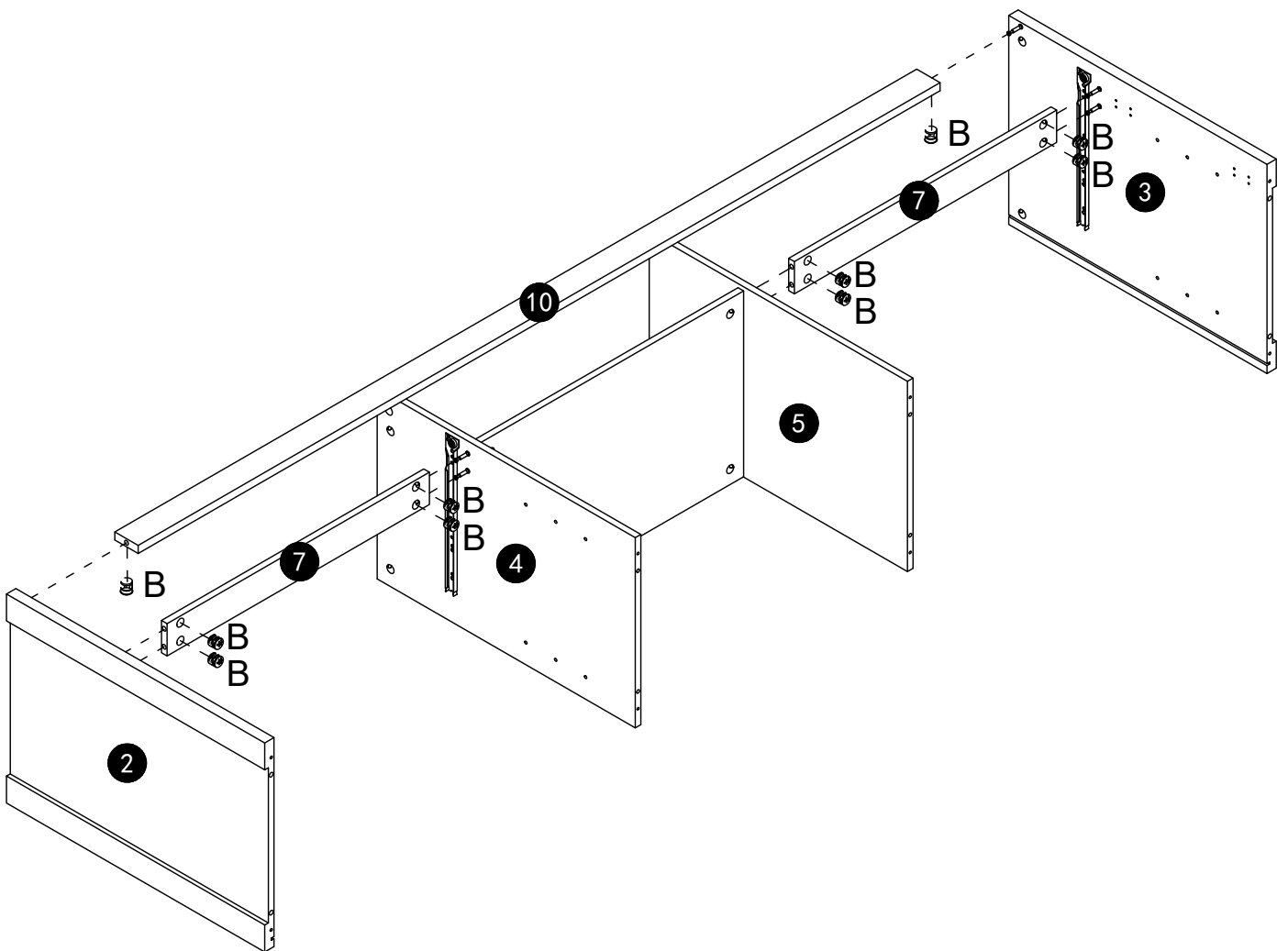
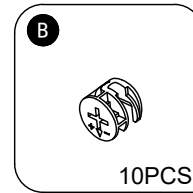

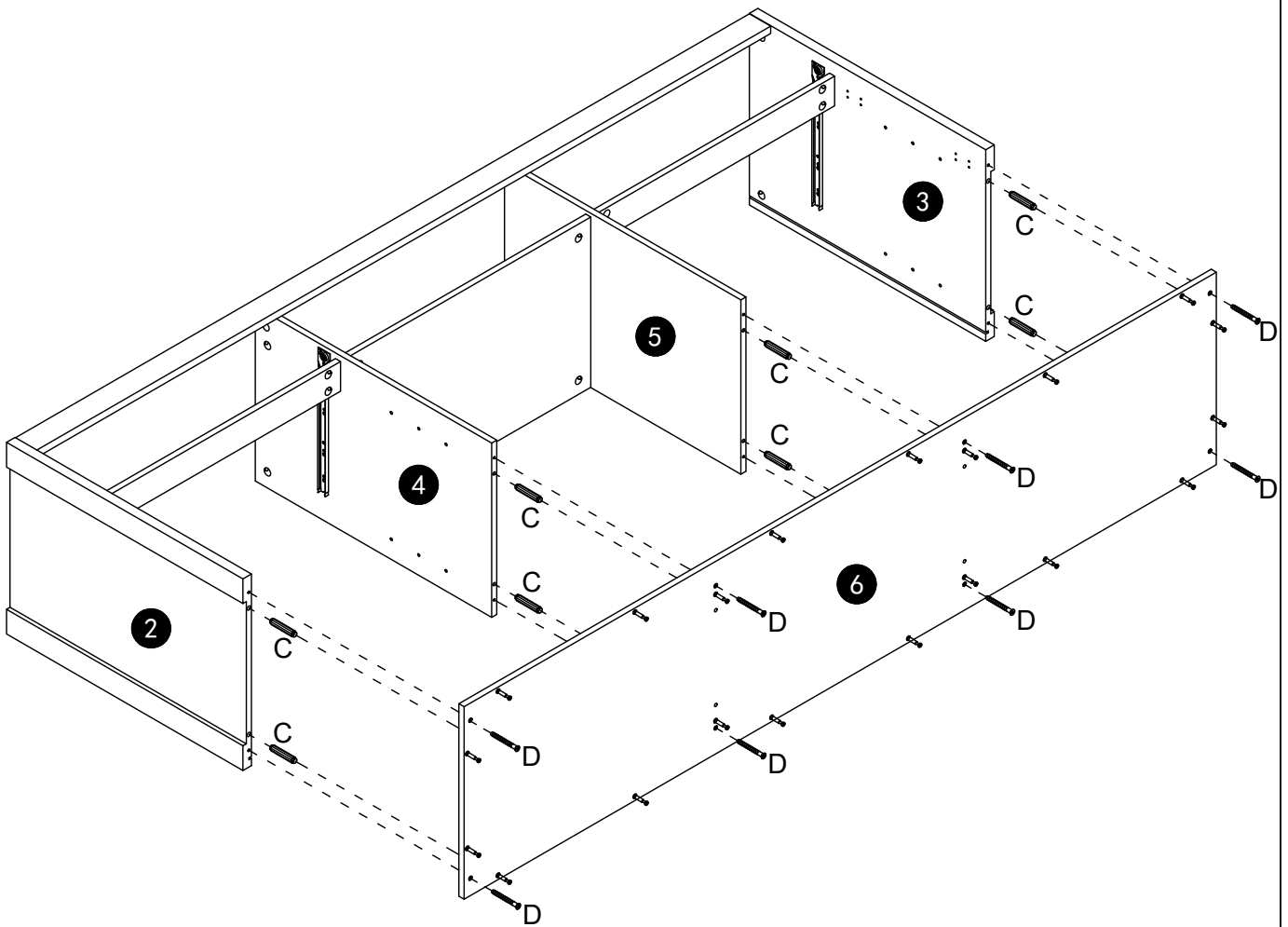
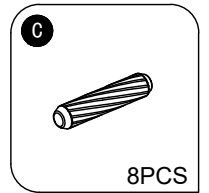
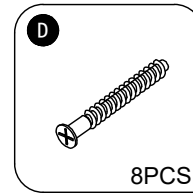

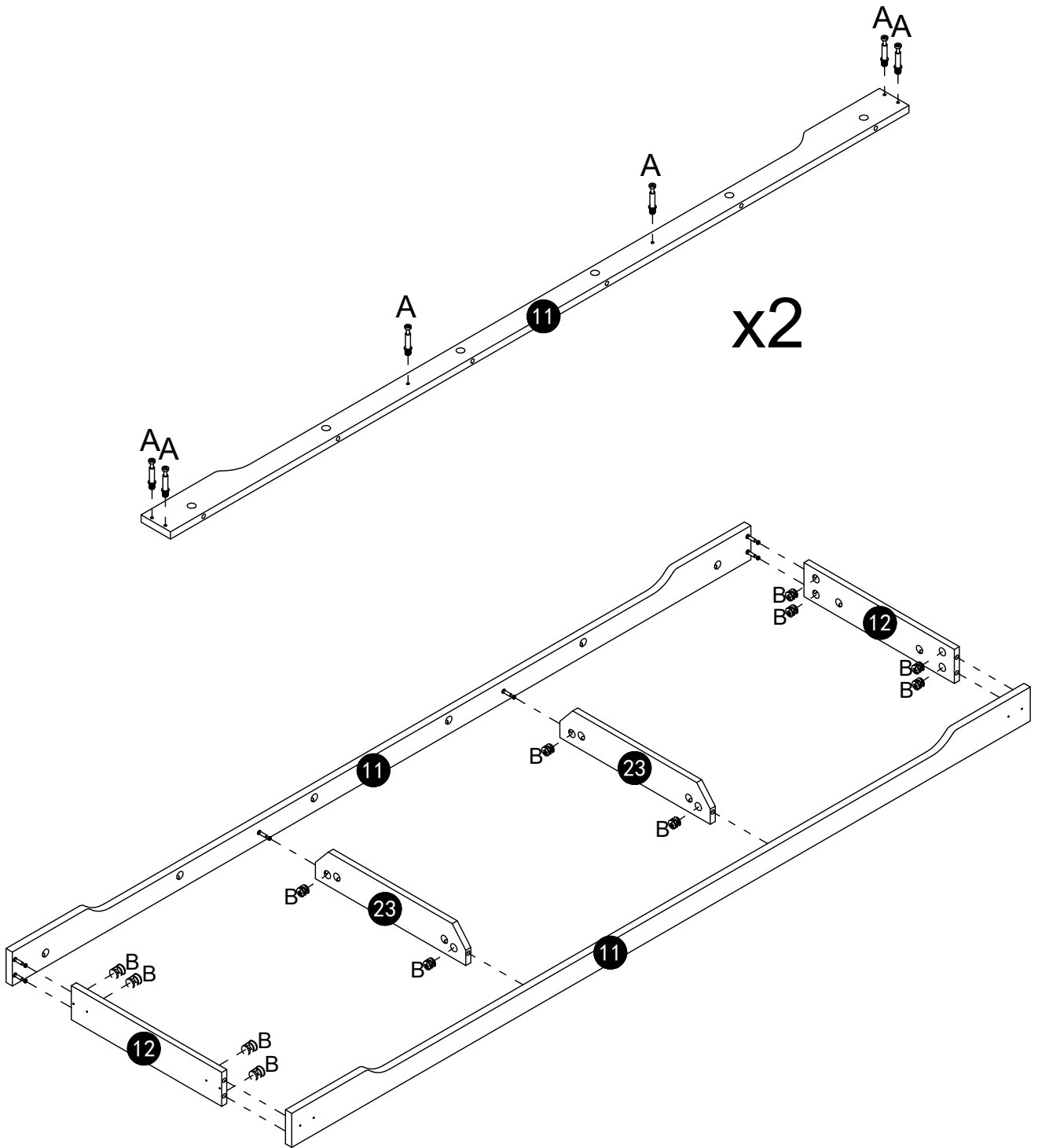
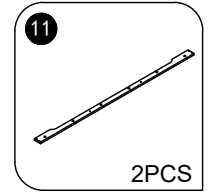
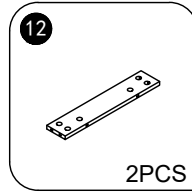
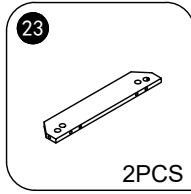
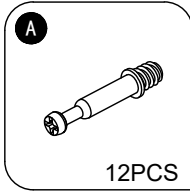
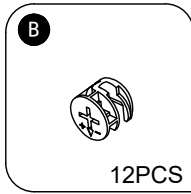

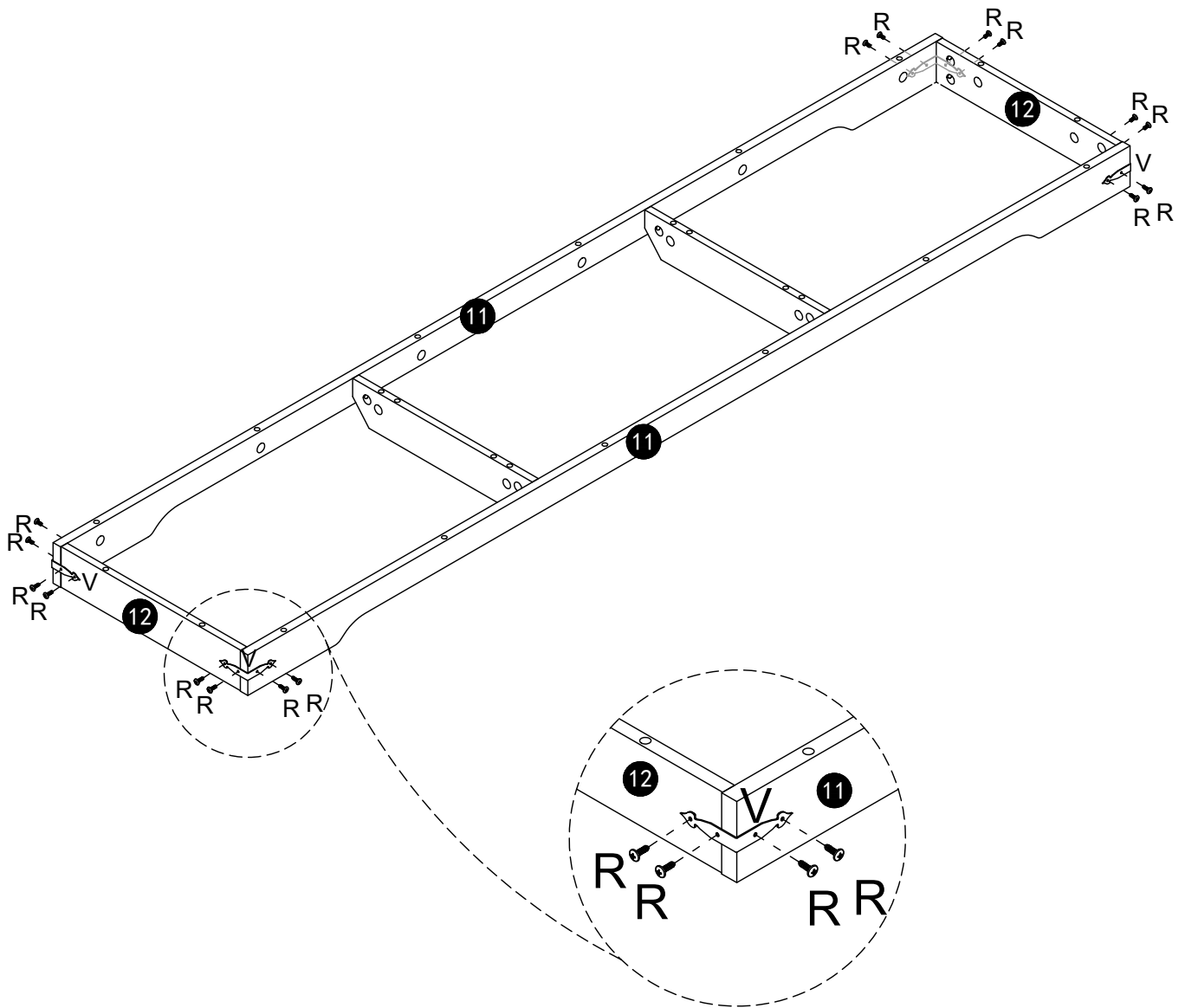
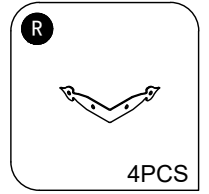
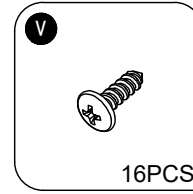

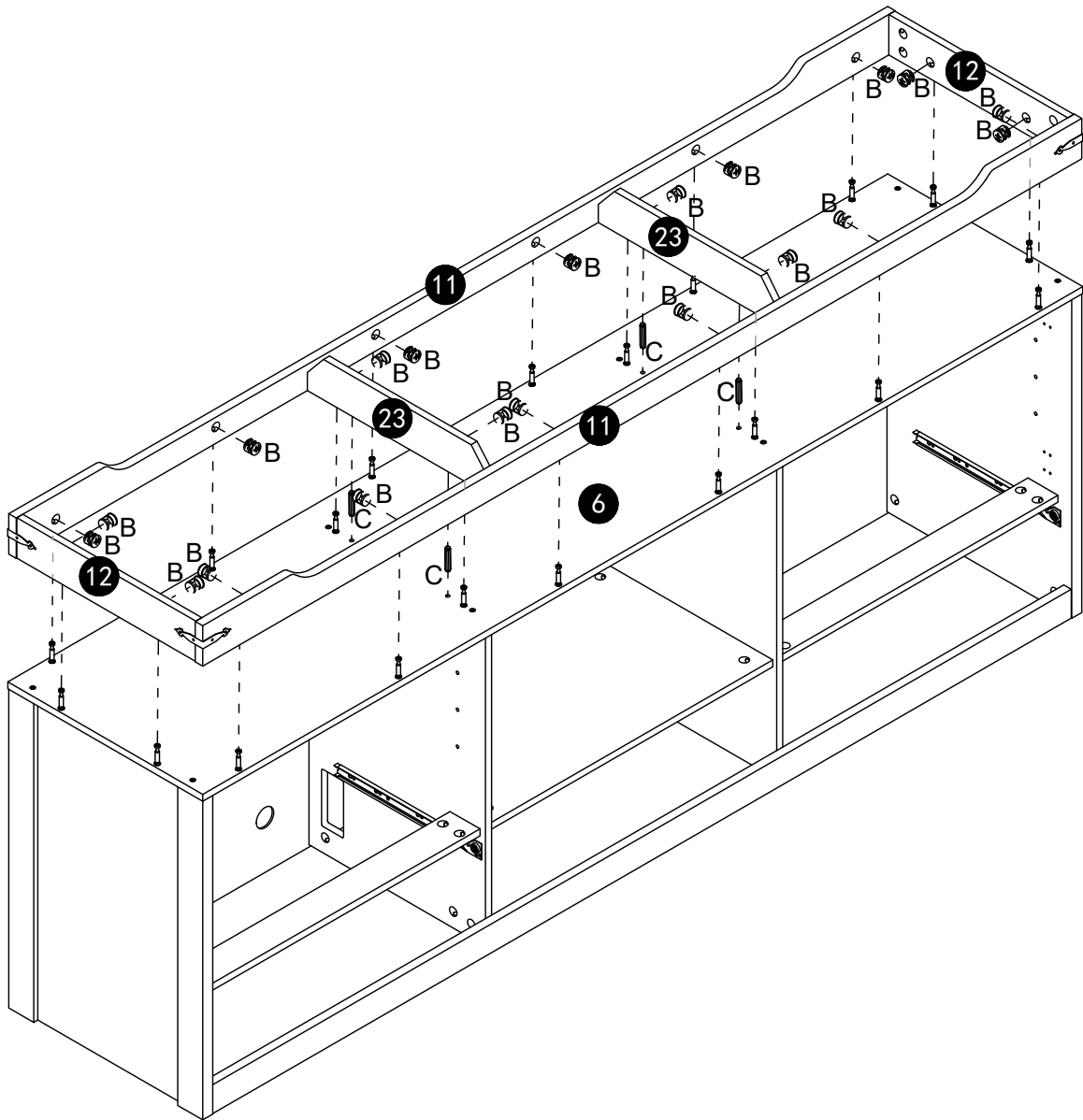
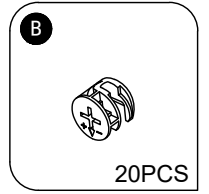
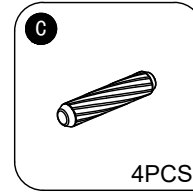

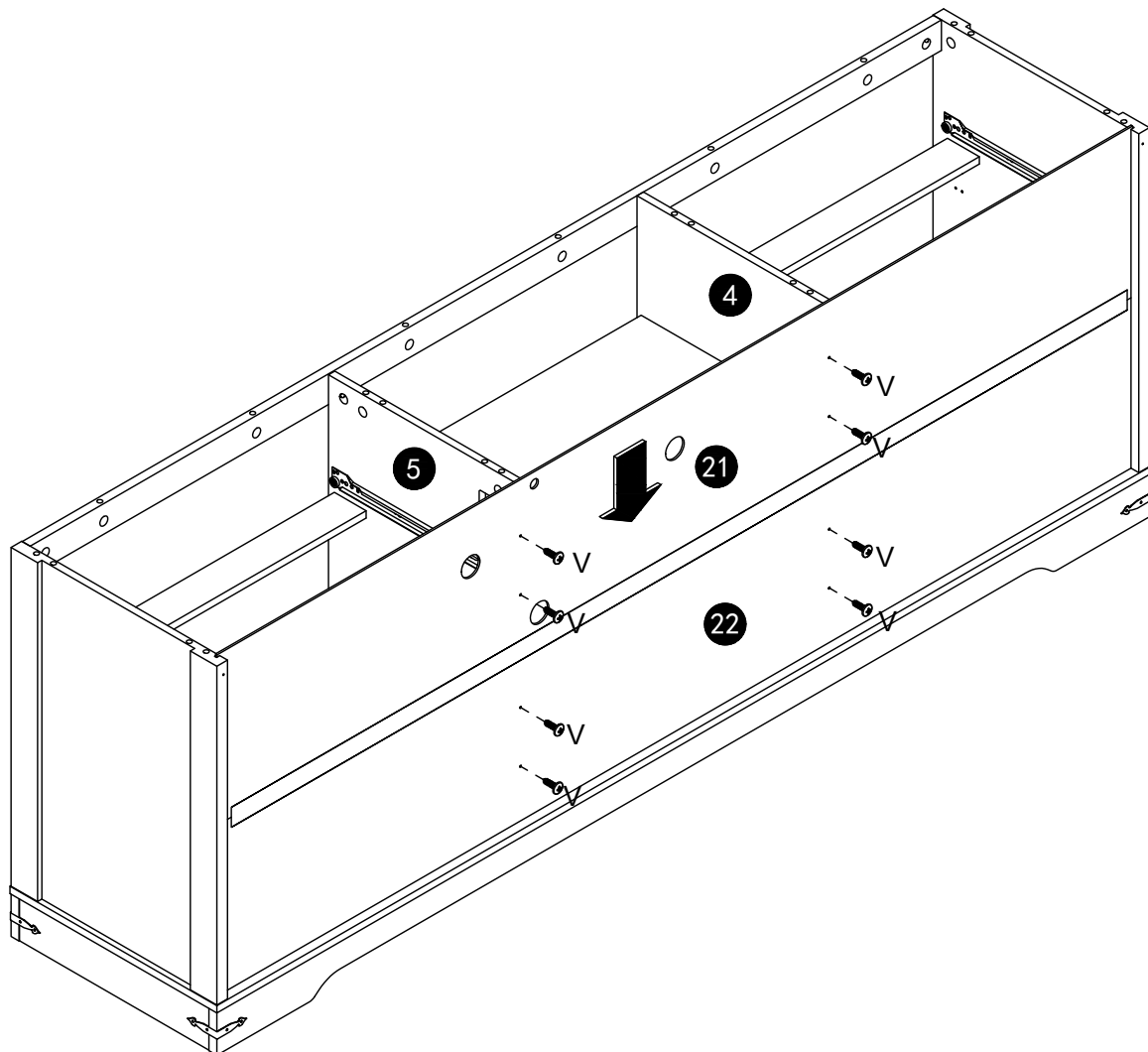
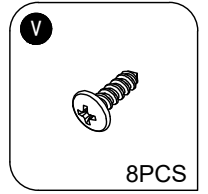
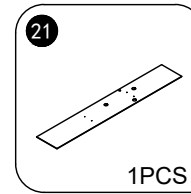
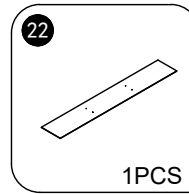

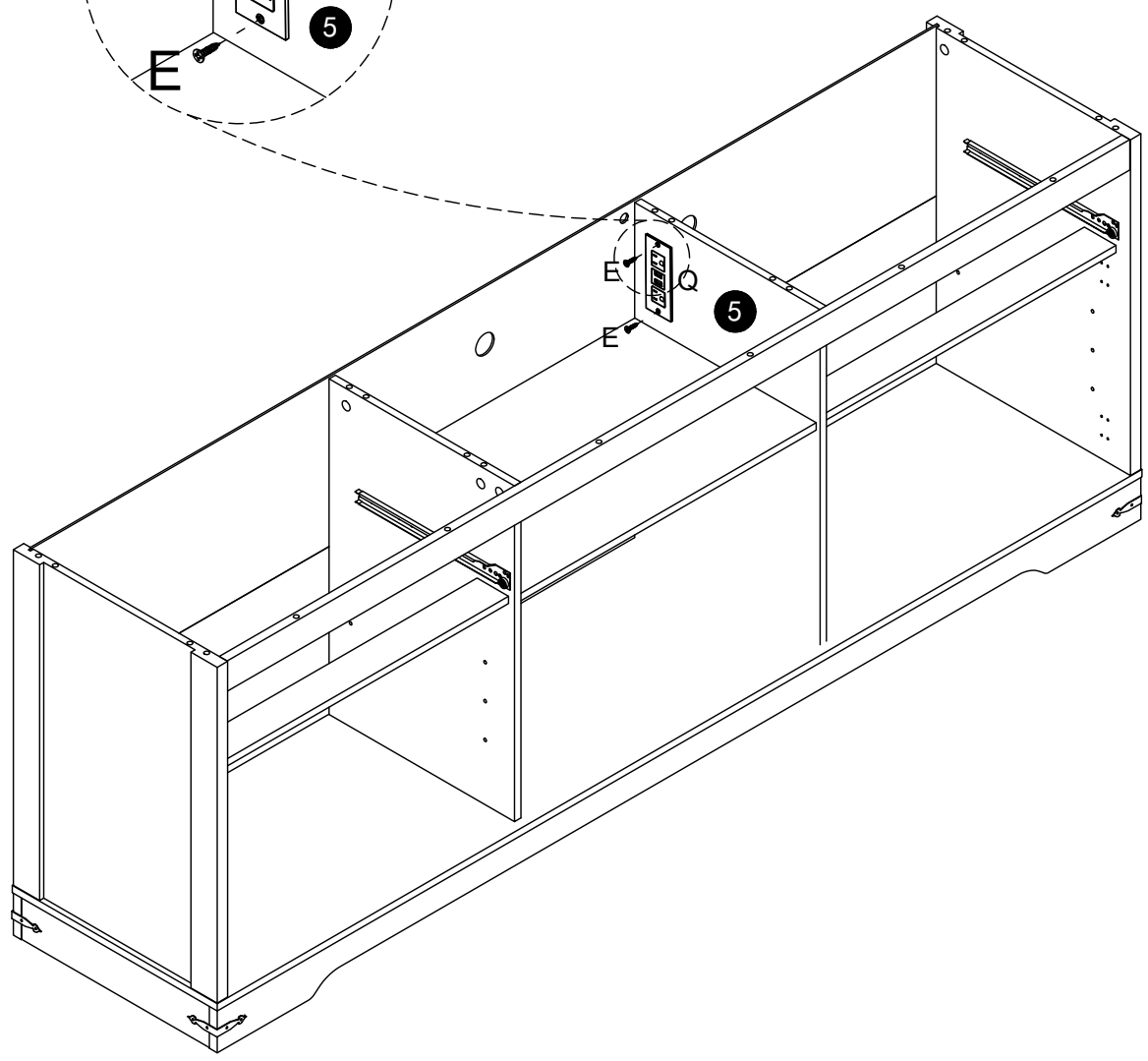
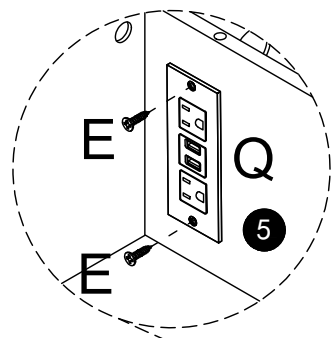
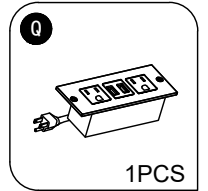
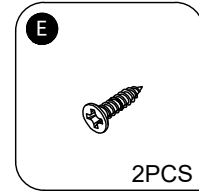

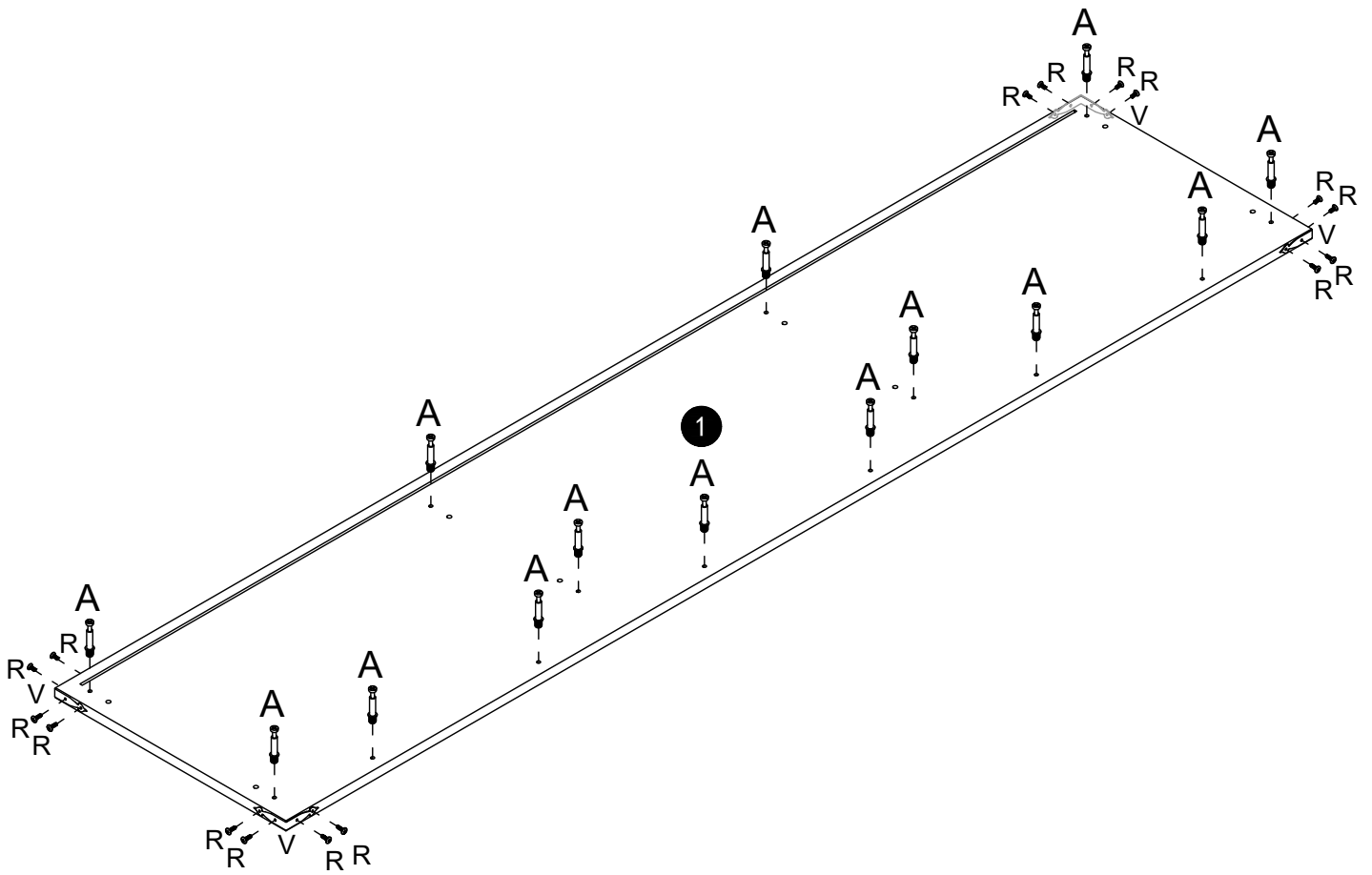
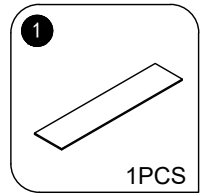
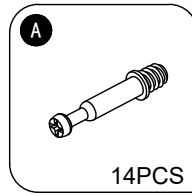
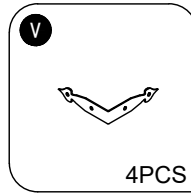
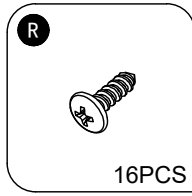

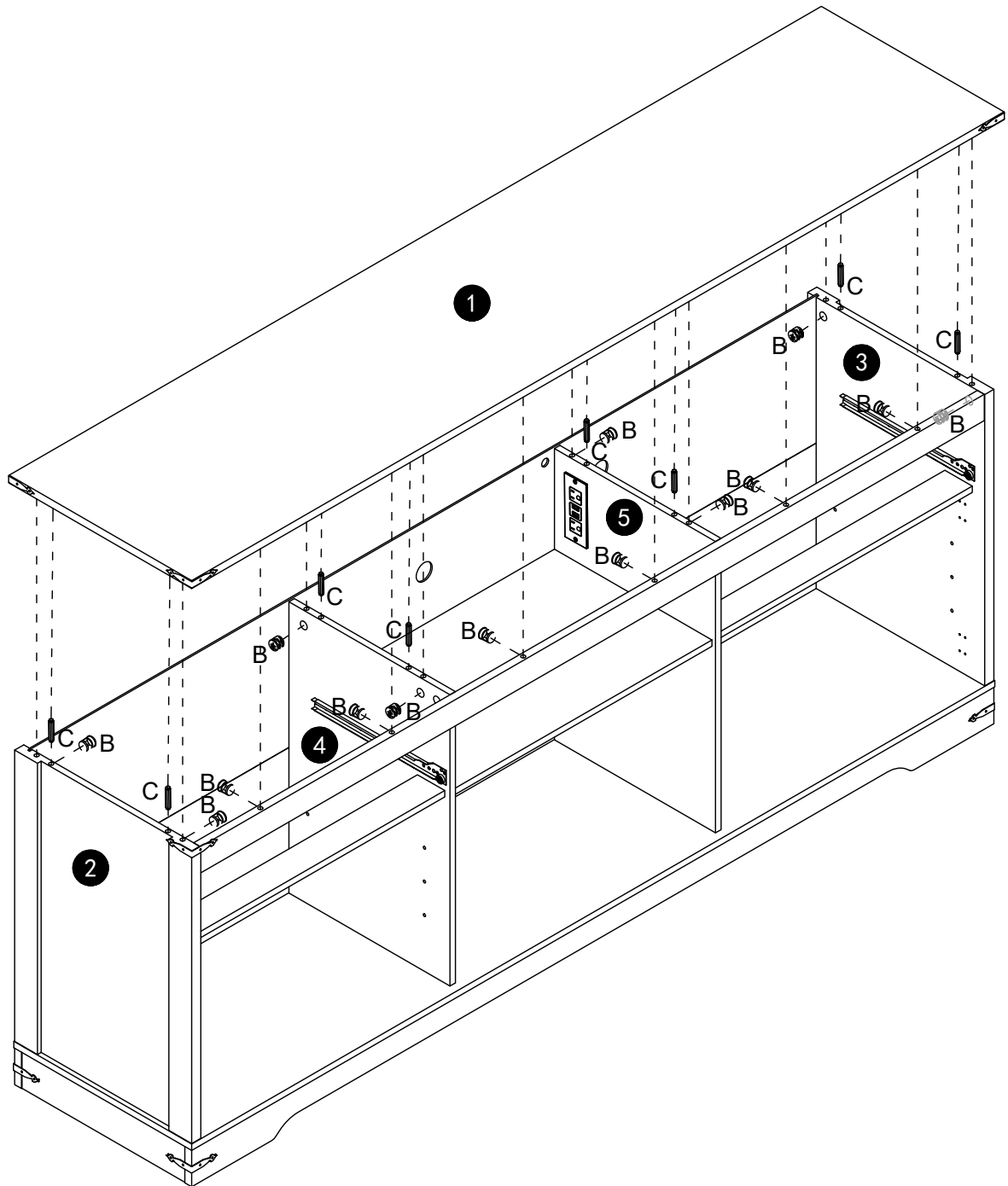
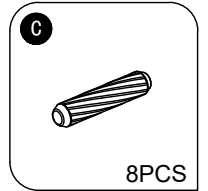
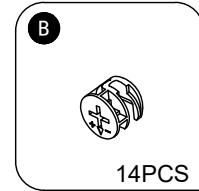

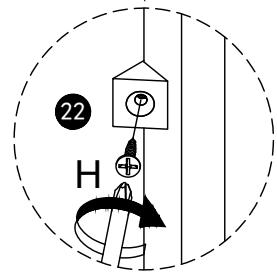
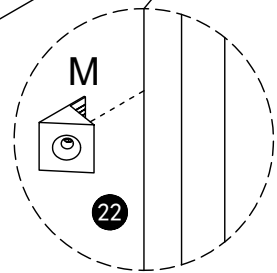
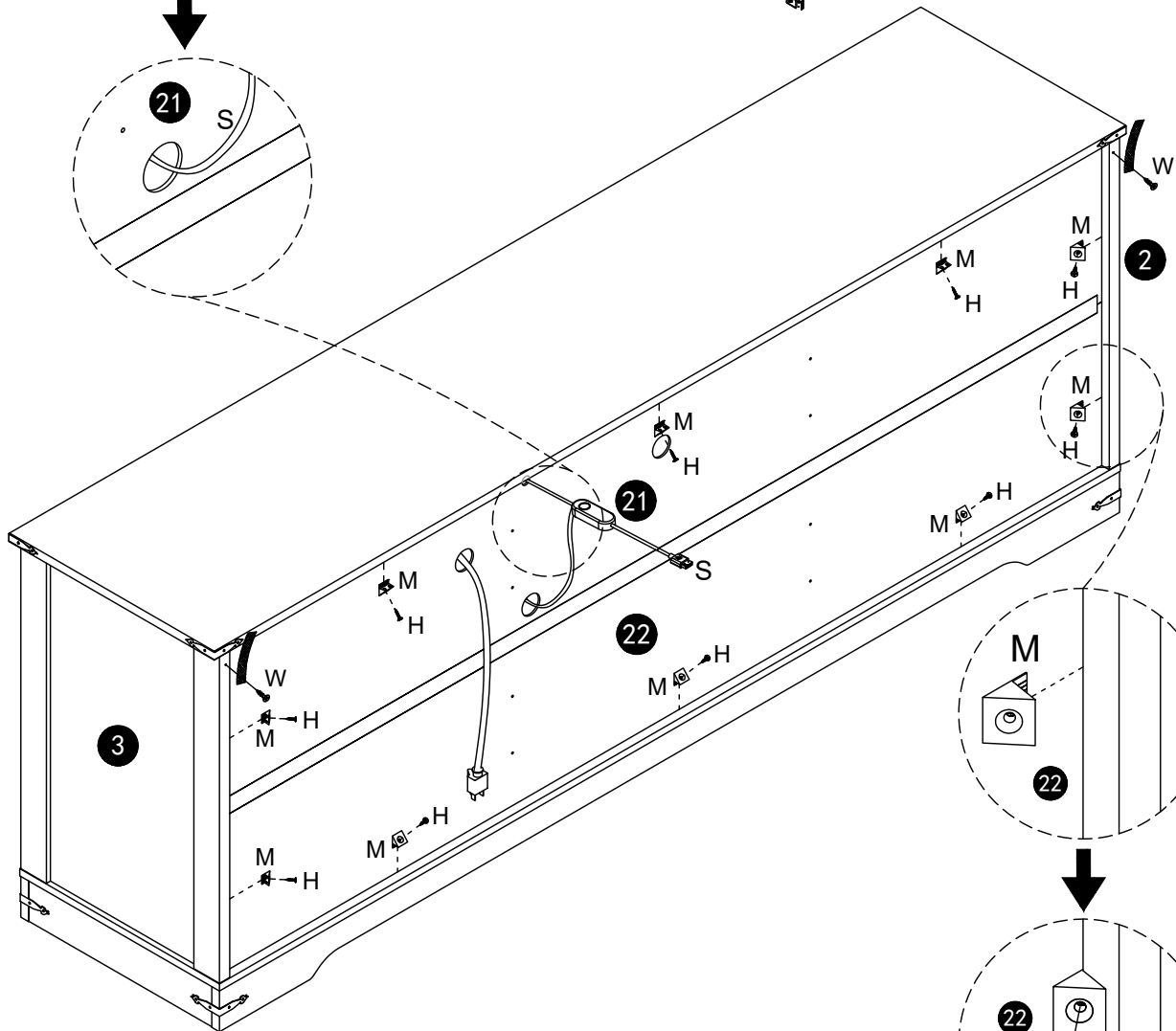
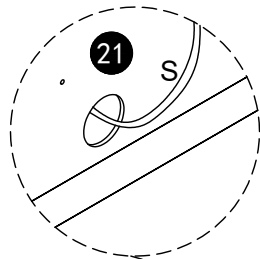
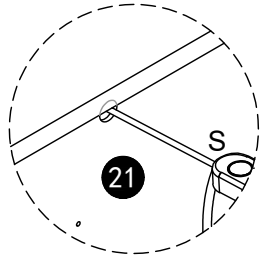
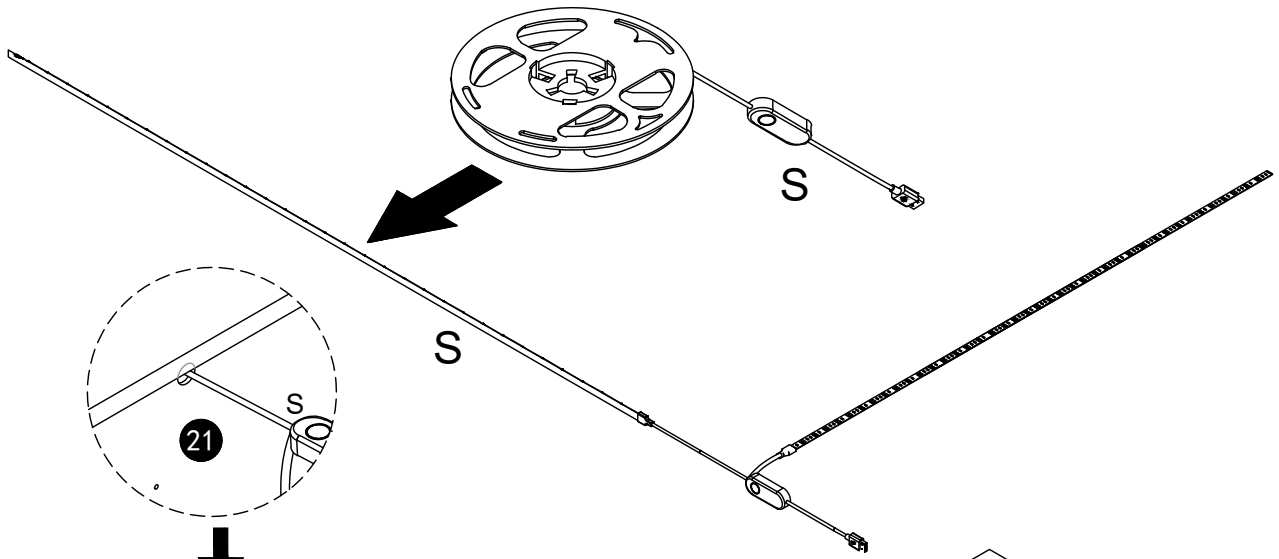
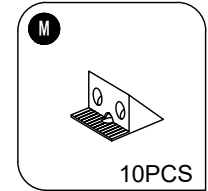
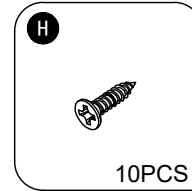
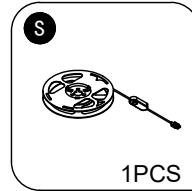

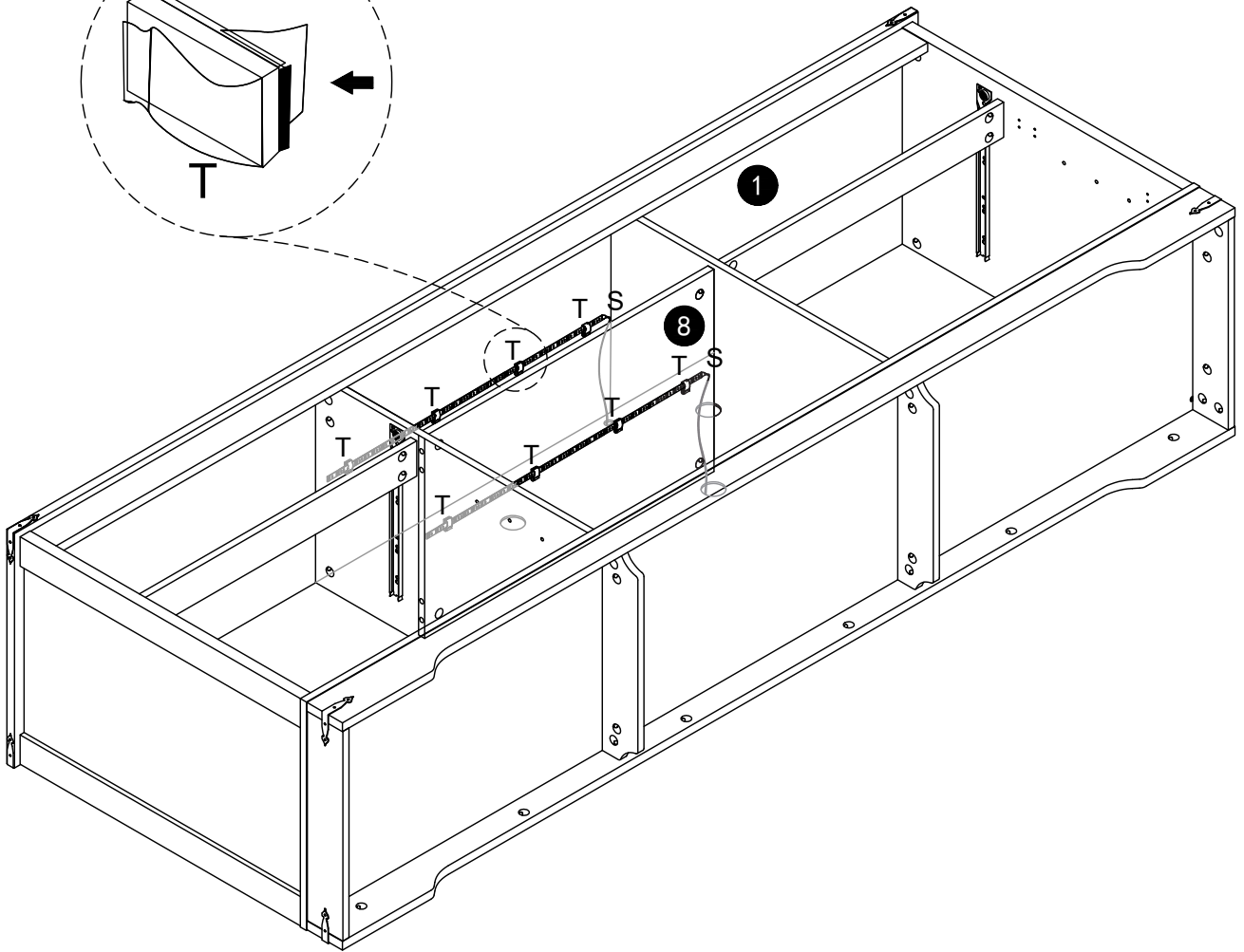
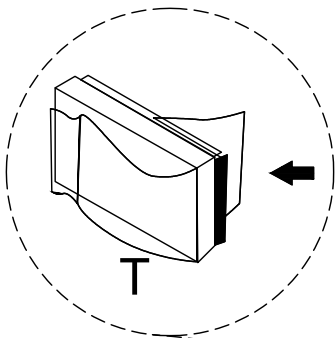
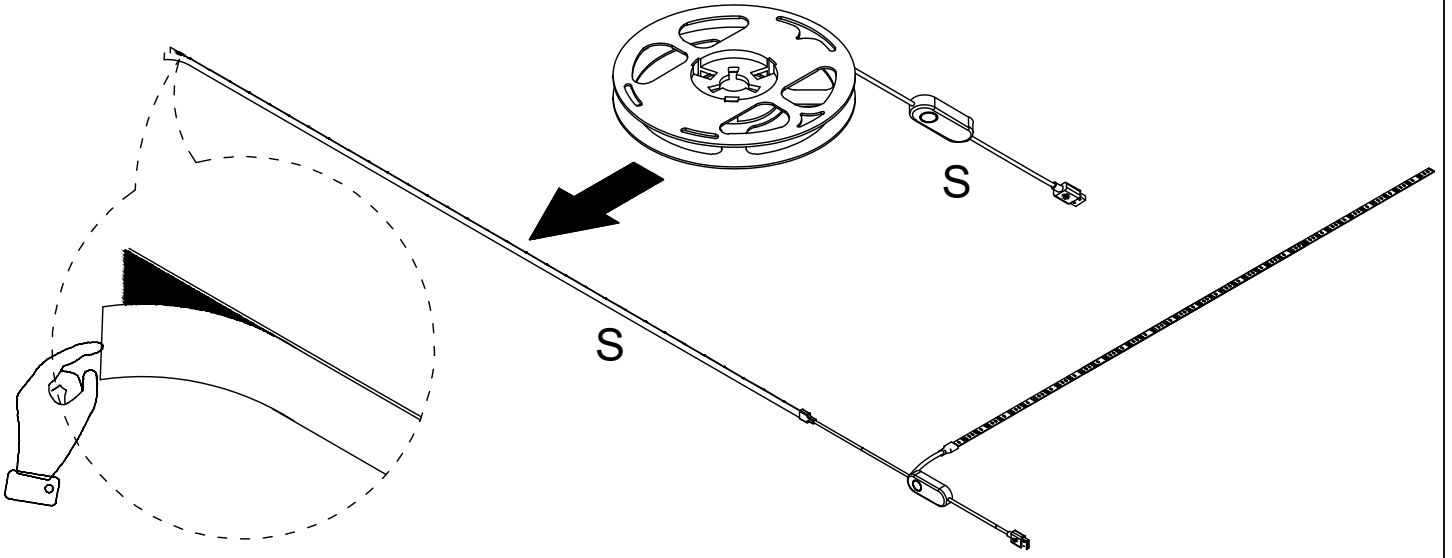
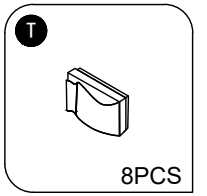

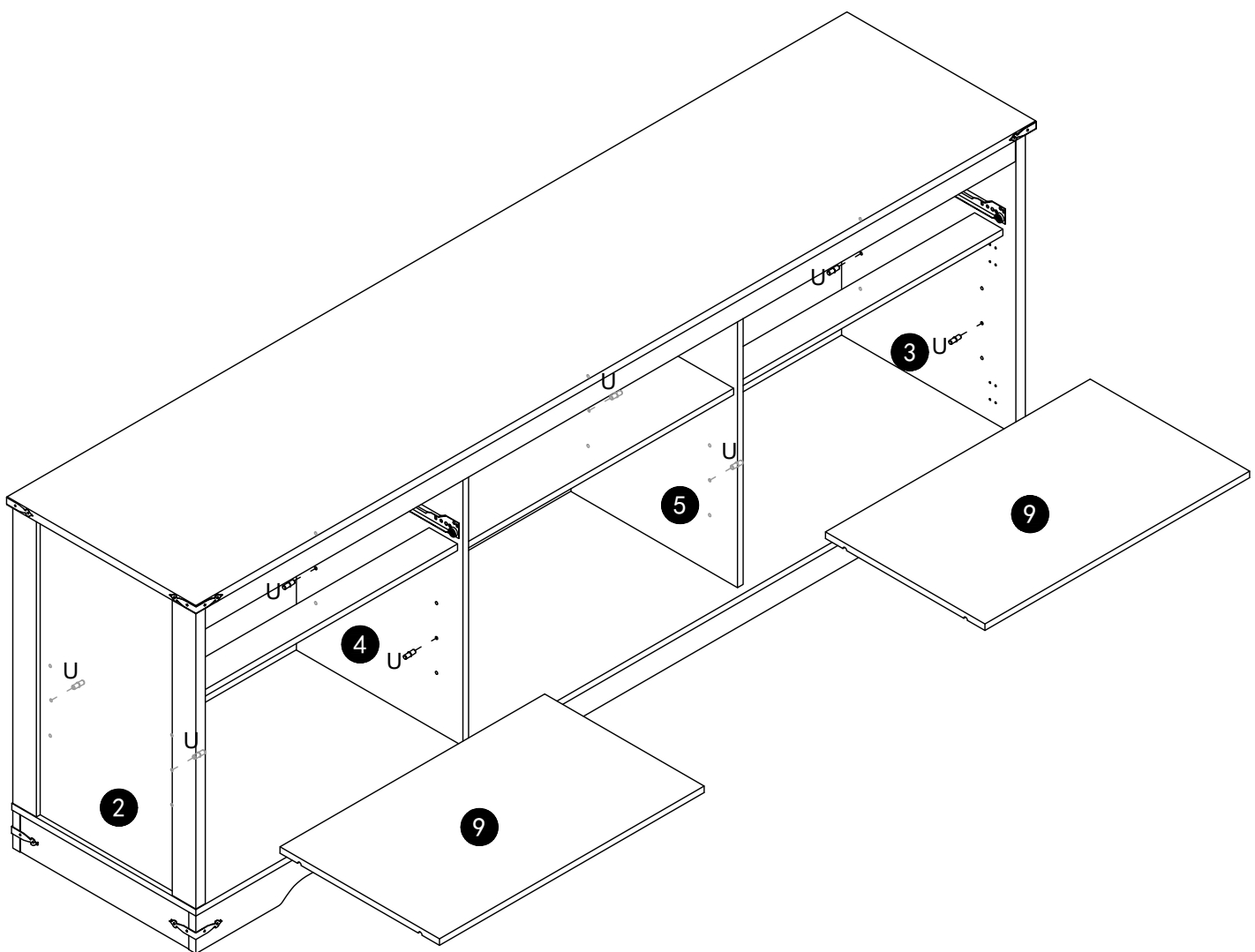
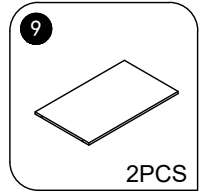
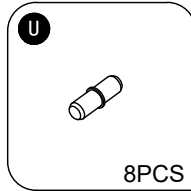

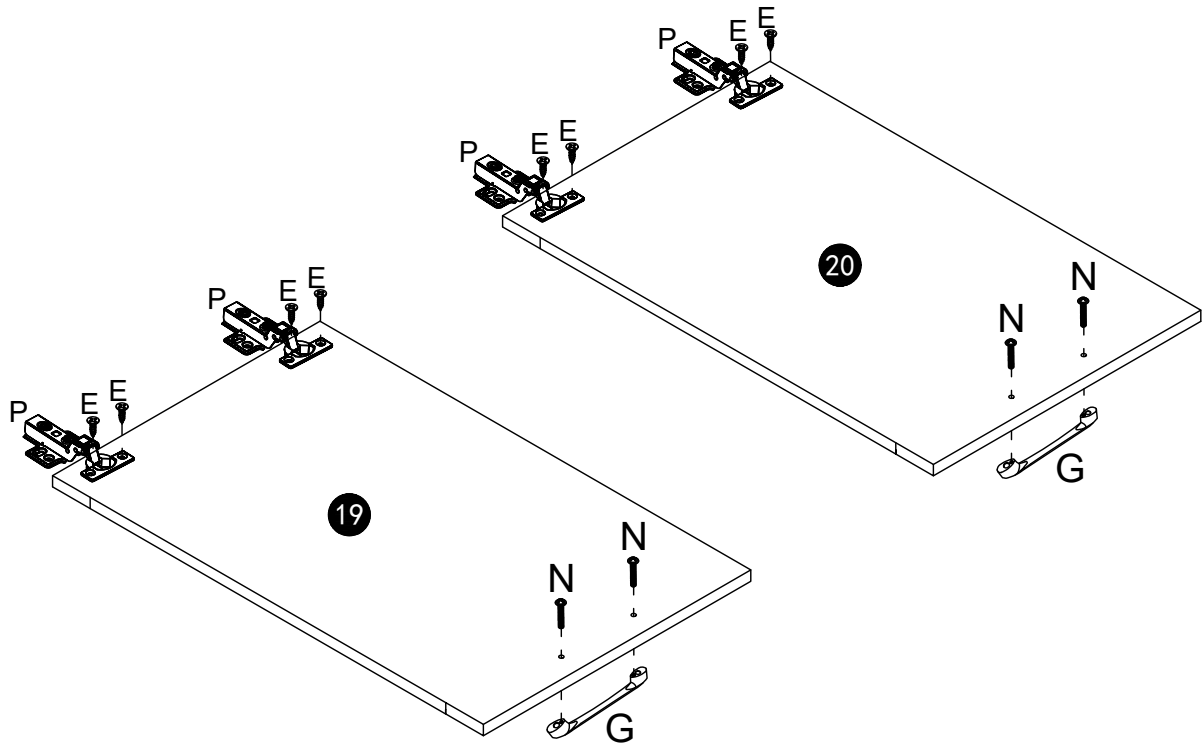
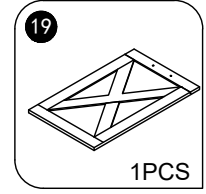
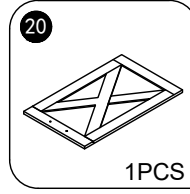
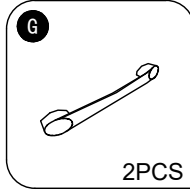
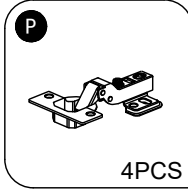
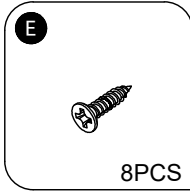

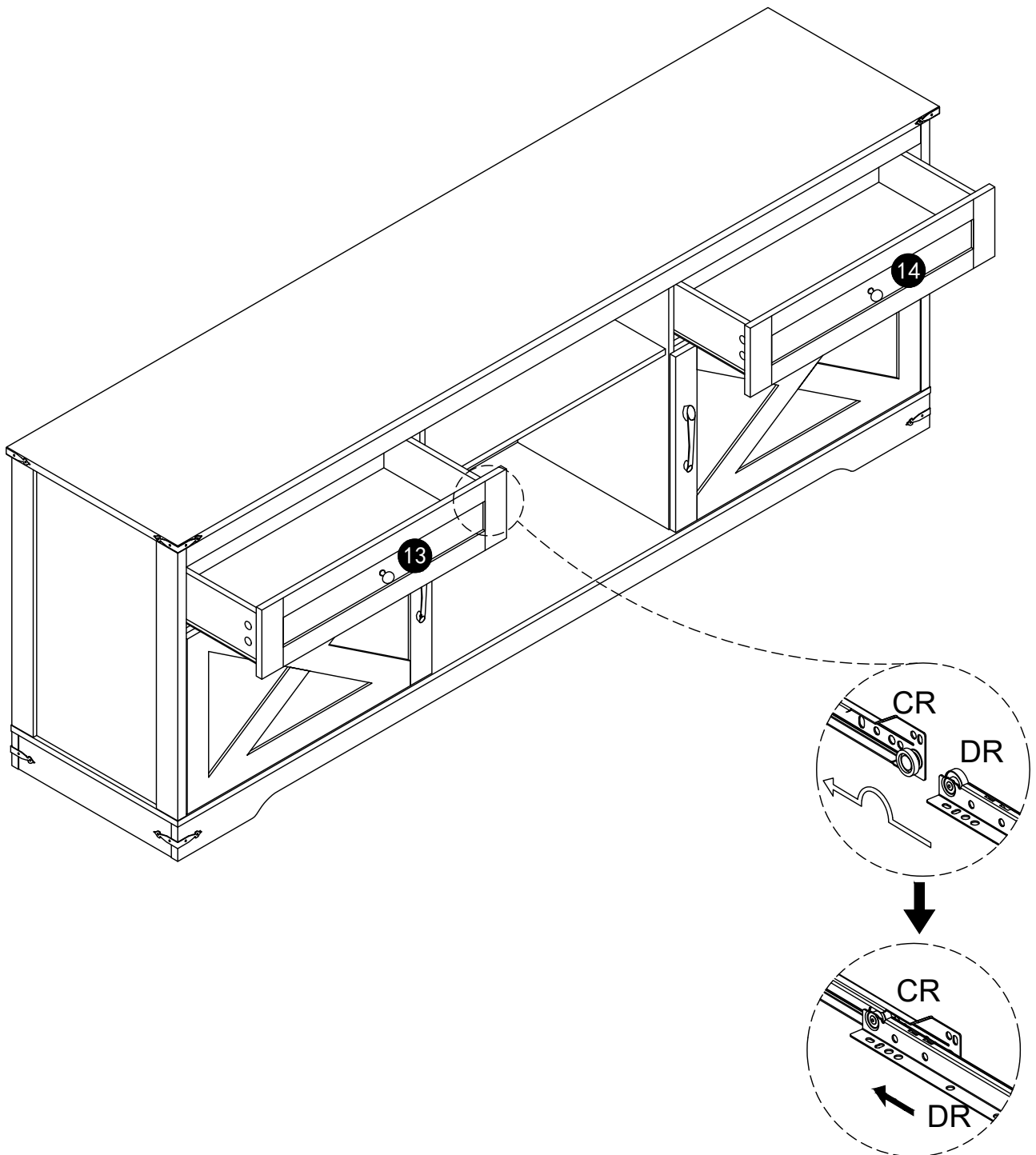

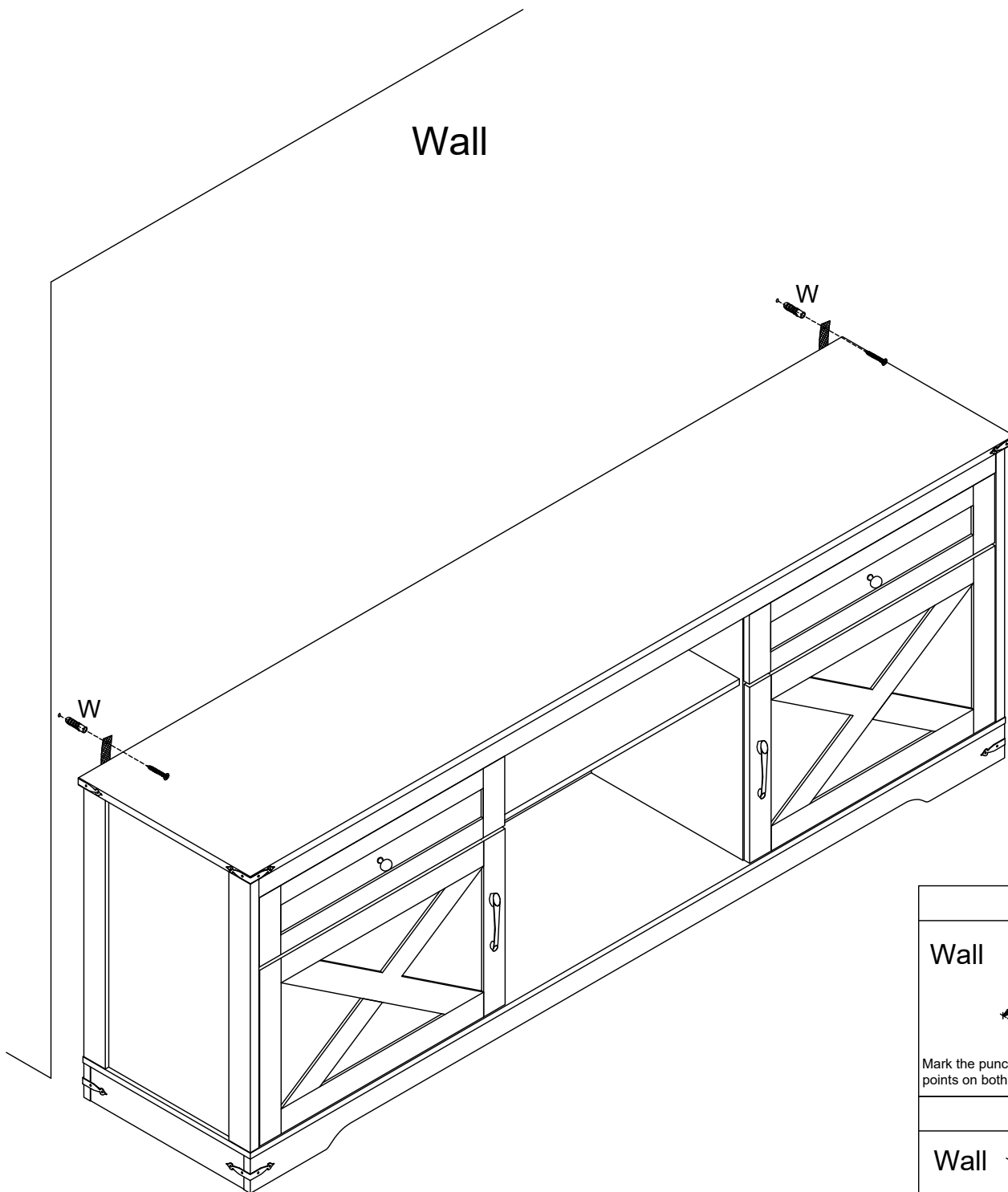
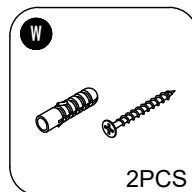

| |
|---|
| 1 |
| <p>Wall</p> <p>Mark the punching points on both sides.</p> |
| 2 |
| <p>Wall</p> <p>Use an electric drill to drill holes at the marked places. Please use a drill bit with a diameter of 6 mm and a length of 30 mm.</p> |
| 3 |
| <p>Wall</p> <p>W x 2</p> |

- Manufacturer and seller expressly disclaim any and all liability for personal injury, property damage or loss, whether direct, indirect, or incidental, resulting from the incorrect attachment, improper use, inadequate maintenance, unapproved modification, or neglect of this product.
- Der Hersteller und Verkäufer lehnen ausdrücklich jegliche Haftung für Personenschäden, Sachschäden oder Verluste ab, egal ob direkt, indirekt oder zufällig, die durch falsche Anbringung, unsachgemäßen Gebrauch, unzureichende Wartung, nicht genehmigte Änderungen oder Vernachlässigung dieses Produkts entstehen.
- El fabricante y vendedor renuncian expresamente a toda responsabilidad por lesiones personales, daños materiales o pérdidas, ya sean directos, indirectos o incidentales, derivados de la incorrecta colocación, uso inadecuado, mantenimiento insuficiente, modificación no aprobada o negligencia de este producto.
- Il produttore e il venditore declinano espressamente ogni responsabilità per lesioni personali, danni materiali o perdite, dirette, indirette o incidentali, derivanti dall'errato fissaggio, uso improprio, manutenzione inadeguata, modifica non autorizzata o negligenza di questo prodotto.
- Le fabricant et le vendeur déclinent expressément toute responsabilité en cas de blessures corporelles, de dommages matériels ou de pertes, qu'ils soient directs, indirects ou accessoires, résultant de la fixation incorrecte, de l'utilisation inappropriée, de l'entretien insuffisant, de la modification non approuvée ou de la négligence de ce produit.