

**INSTRUCTION MANUAL ENCLOSED**

**ATTENTION**

**IF YOU HAVE ANY PROBLEMS OR QUESTIONS, EMAIL OR CALL  
CUSTOMER SERVICE BEFORE YOU RETURN THIS PRODUCT TO THE  
STORE WHERE IT WAS PURCHASED.**

**INSTRUCTION MANUAL ENCLOSED**

# COFFEE TABLE

## COFFEE TABLE INSTRUCTION



Part	PARTS LIST Description	Quantity
<i>PARTS</i>		
A	Wicker Table Top	1
B	Glass Table Top	1
C	Table Base	1
D	Table Feet	3
<i>HARDWARE</i>		
E	Bolts M6*20mm	3
F	Bolts M6*16mm	3
G	Washers 1	6
H	Washers 2	6
I	Allen Key	1

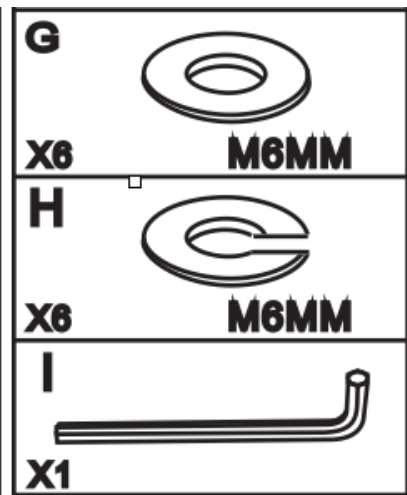
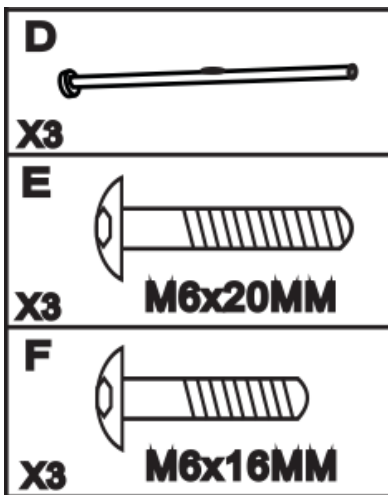
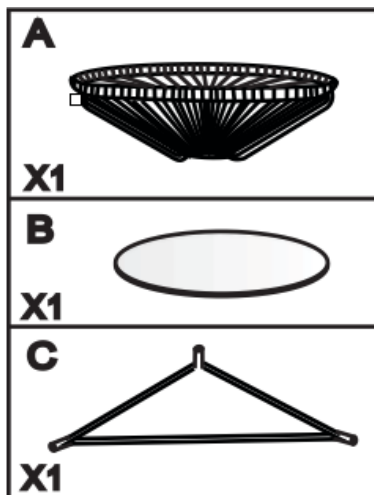

## PLEASE READ AND FOLLOW ALL SAFETY TIPS

### GETTING STARTED

1. Before assembly, CAREFULLY use scissors or utility knife to cut and unwrap all parts. Make sure you do not discard the hardware.

1. Locate 3 Table Feet(D) to the Wicker Table Top(A) by the pre-drilled threads. Fasten Bolts(E) with Washers 1(H) and Washers 2(G) by using Allen Key(I). (Photo 1).



2. Locate Table Base(C) to Table Feet(D) by the pre-drilled threads. Fasten Bolts(F) with Washers 1(H) and Washers 2(G) by using Allen Key(I). Put Glass Table Top(B) on top of the Wicker Table Top(A) (Photo 2)

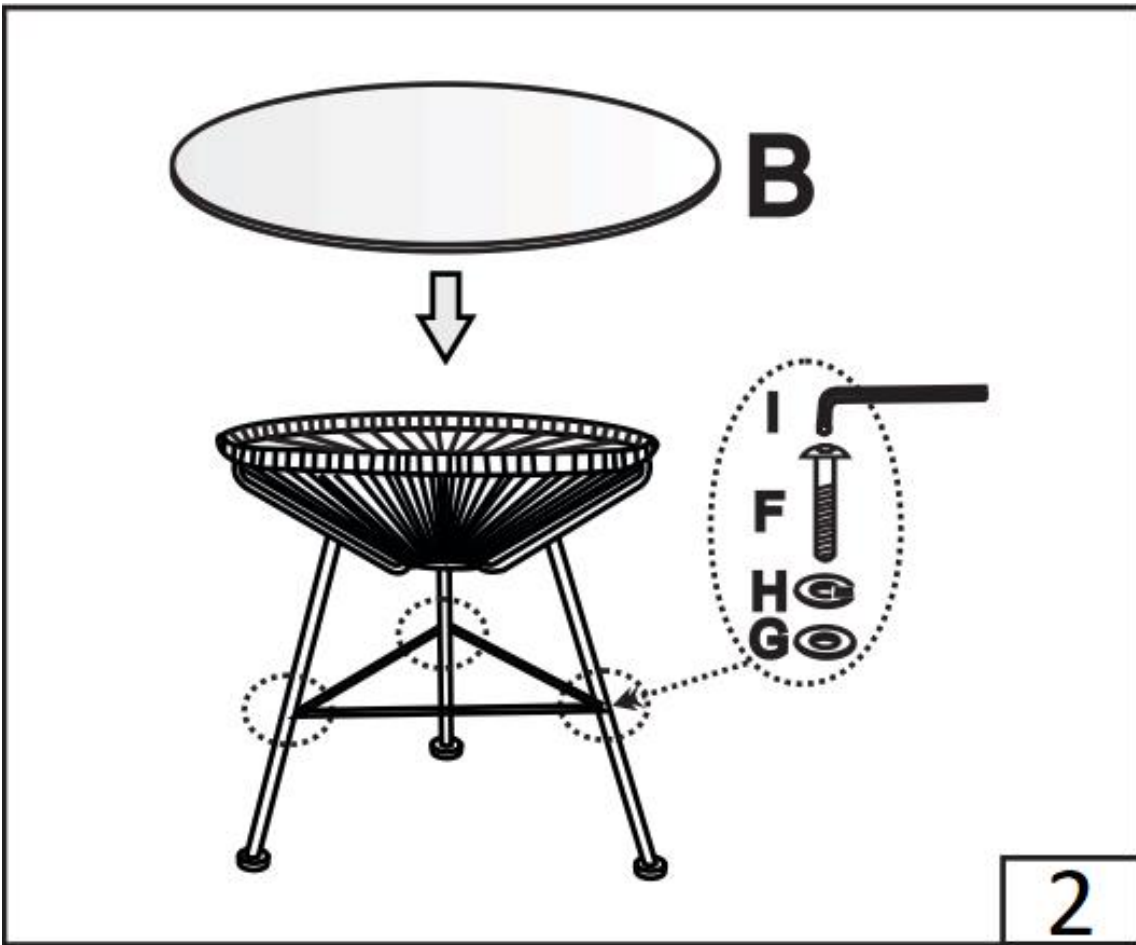

Till now you have finished the whole assembly and enjoy your coffee with this table!!