

ASSEMBLY INSTRUCTIONS

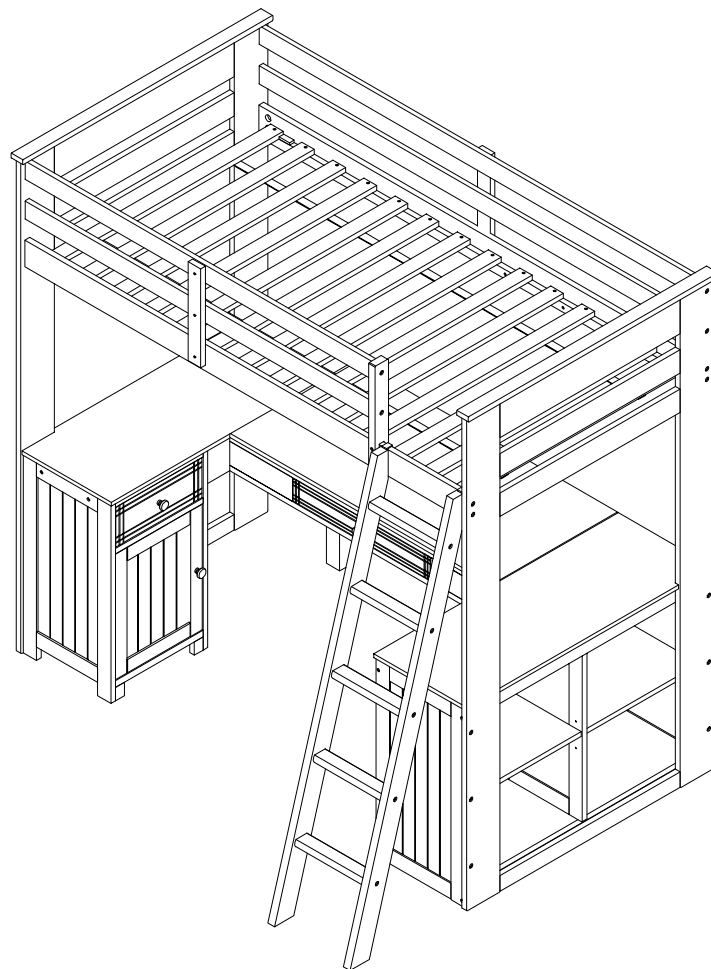















*** Thank you for purchasing this quality product. Be sure to check all packing materials carefully for small parts which may have come loose inside the carton during shipment. Identify and count all parts and compare with parts list below.

*** Assemble product on a flat, soft surface such as a carpet or cloth to prevent scratching the finish. Read all instruction and study the drawings carefully before starting the assembly process.







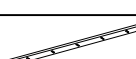
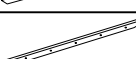
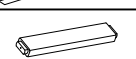
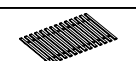
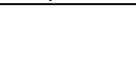









IMPORTANT: Do not tighten bolts completely until all bolts are completely lined up and inserted into holes

PARTS LIST

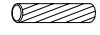
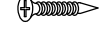
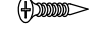





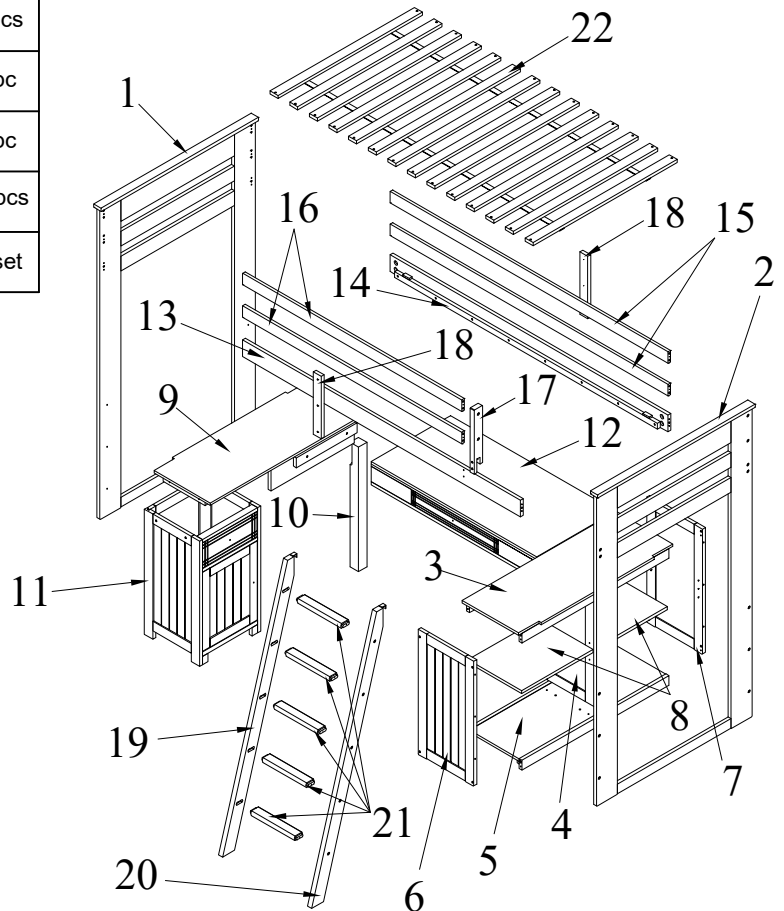





















NO.	DIAGRAM	PART NAME	Q'Ty
1		Headboard Left	1 pc
2		Headboard Right	1 pc
3		Right Bookcase-Top Panel	1 pc
4		Right Bookcase - Center Panel	1 pc
5		Right Bookcase - Bottom Panel	1 pc
6		Right Bookcase - Left Panel	1 pc
7		Right Bookcase - Left Panel	1 pc
8		Right Bookcase - Shelf Panel	2 pcs
9		Nightstand - Top Panel	1 pc
10		Legs	1 pc
11		Nightstand	1 pc
12		Desk	1 pc
13		Front Rail	1 pc
14		Back Rail	1 pc
15		Long Guardrail (Back)	2 pcs
16		Short Guardrail (Front)	2 pcs
17		Guardrail Attachment	1 pc
18		Guardrail Support	2 pcs
19		Ladder Rail (Left Side)	1 pc
20		Ladder Rail (Right Side)	1 pc
21		Ladder Step	5 pcs
22		Completed Twin Slat (14pcs / 1set)	1 set

HARDWARE LIST

NO.	DIAGRAM	PART NAME	Q'Ty
A		Bolt: 6.3 * 60 (mm)	10 pcs
B		Half Round Nut	8 pcs
C		Spring Washer	2 pcs
D		Flat Washer	2 pcs
E		Short Bolt 6.3 x 15 (mm)	2 pcs
F		Short Bolt 6.3 x 30 x 11.5 (mm)	19 pcs
G		Short Bolt 6.3 x 55 (mm)	1 pcs
H		Short Bolt 6.3 x 30 x 15 (mm)	11 pcs
I		Screw Bolt 7 x 50 (mm)	8 pcs
J		Screw Bolt 7 x 50 (mm)	10 pcs
K		Wood Dowel 10 x 40 (mm)	30 pcs
L		Screw: 4 * 30 (mm)	34 pcs
M		Screw: 4 * 20 (mm)	6 pcs
N		Screw: 3.5* 15 (mm)	8 pcs
O		Small L Shape Connection Braket	8 pcs
P		Big L Shape Connection Braket	2 pcs
Q		Allen Key (M4)	1 pc



packed in 4 cases

Carton	Disignation	Part	Hardware
	Headboard Left x 1pc	#1 	 A: Bolt: 6.3 * 60 (mm) x 10pcs  B: Half Round Nut x 8pcs  C: Spring Washer x 2pcs  D: Flat Washer x 2pcs  E: Short Bolt 6.3 x 15 (mm) x2pcs  F: Short Bolt 6.3 x 30 x 11 (mm) x 19pcs  G: Short Bolt 6.3 x 55 (mm) x1pc  H: Short Bolt 6.3 x 30 x 15 (mm) x 11pcs  I: Screw Bolt 7 x 50 (mm) x 8pcs  J: Screw Bolt 7 x 50 (mm) x 10pcs  K: Wood Dowel 10 x 40 (mm) x30pcs  L: Screw: 4 * 30 (mm) x34pcs  M: Screw: 4 * 20 (mm) x 6pcs  N: Screw: 4 * 15 (mm) x 8pcs  O: Small L Shape Connection Braket x 8pcs  P: Big L Shape Connection Braket x 2pcs  Q: Allen Key (M4) x 1pc
	Headboard Right x 1pc	#2 	
	Front Rail x 1pc	#13 	
	Back Rail x 1pc	#14 	
	Long Guardrail (Back) x 2pcs	#15 	
	Short Guardrail (Front) x 2pcs	#16 	
	Guardrail Attachment x 1pc	#17 	
	Guardrail Support x 2pcs	#18 	
	Ladder Rail (Left Side) x 1pc	#19 	
	Ladder Rail (Right Side) x 1pc	#20 	
	Ladder Step x 5pcs	#21 	
	Completed Twin Slat (14pcs / 1set)	#22 	
	Nightstand - Top Panel x 1pc	#9	
	Legs x 1pc	#10	
	Nightstand x 1pc	#11	
	Desk x 1pc	#11	
	Right Bookcase-Top Panel x 1pc	#3	
	Right Bookcase - Center Panel x 1pc	#4	
	Right Bookcase - Bottom Panel x 1pc	#5	
	Right Bookcase - Left Panell x 1pc	#6	
	Right Bookcase - Left Panel x 1pc	#7	
	Right Bookcase - Shelf Panel x 1pc	#8	

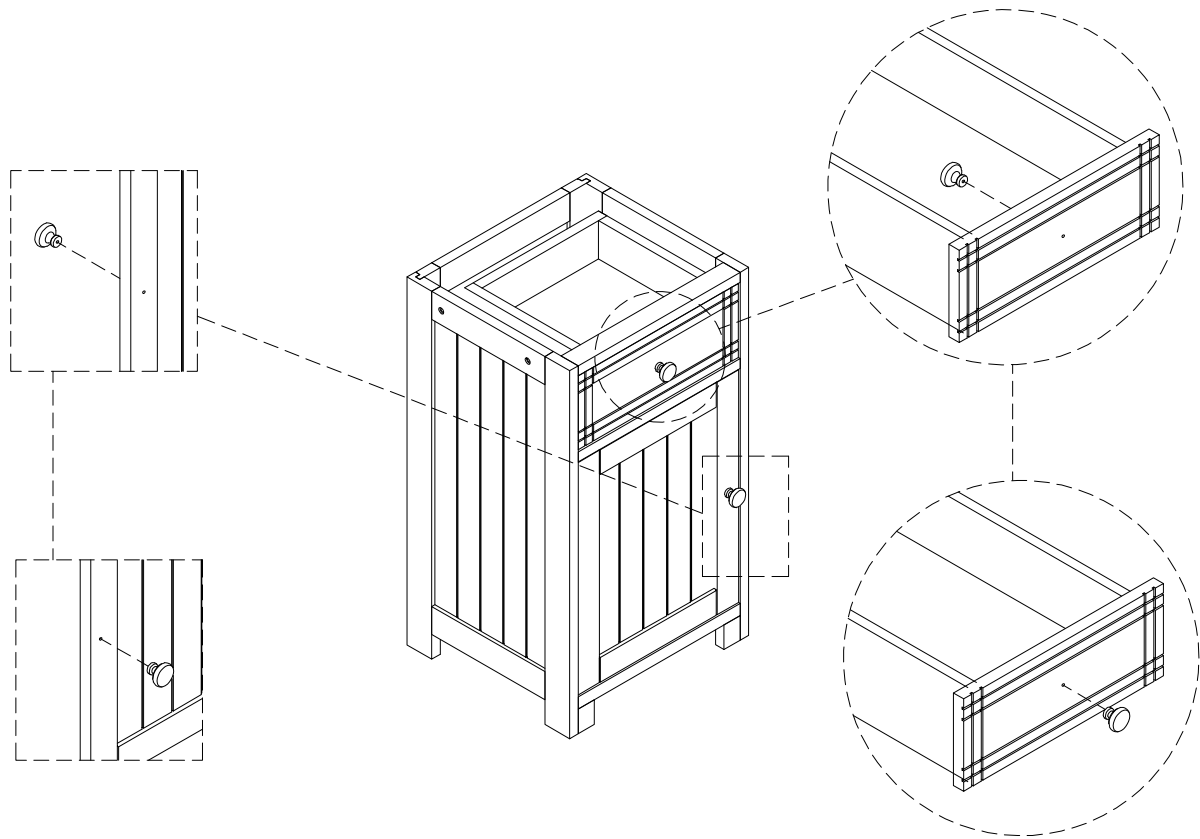

STEP 1:

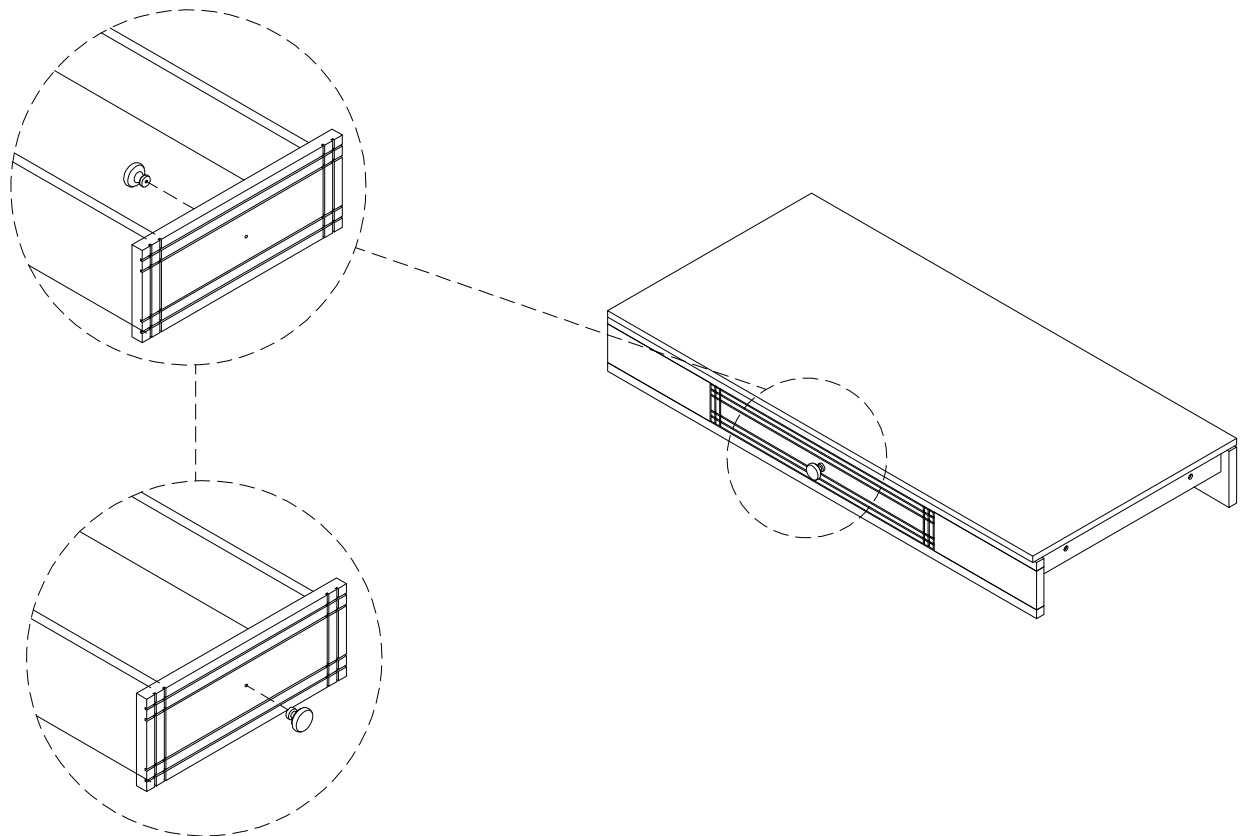

STEP 2:



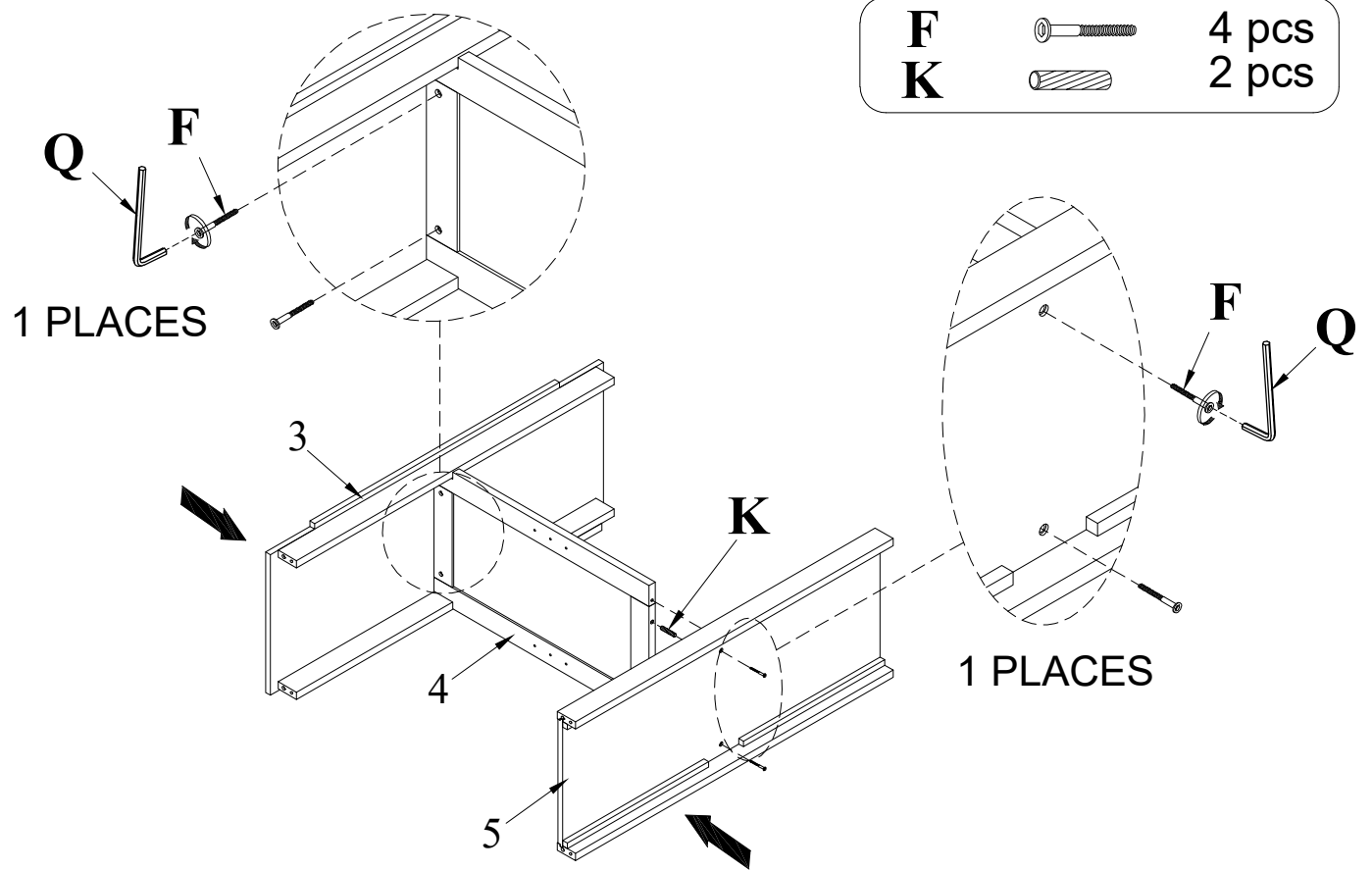

STEP 3:

F		4 pcs
K		2 pcs



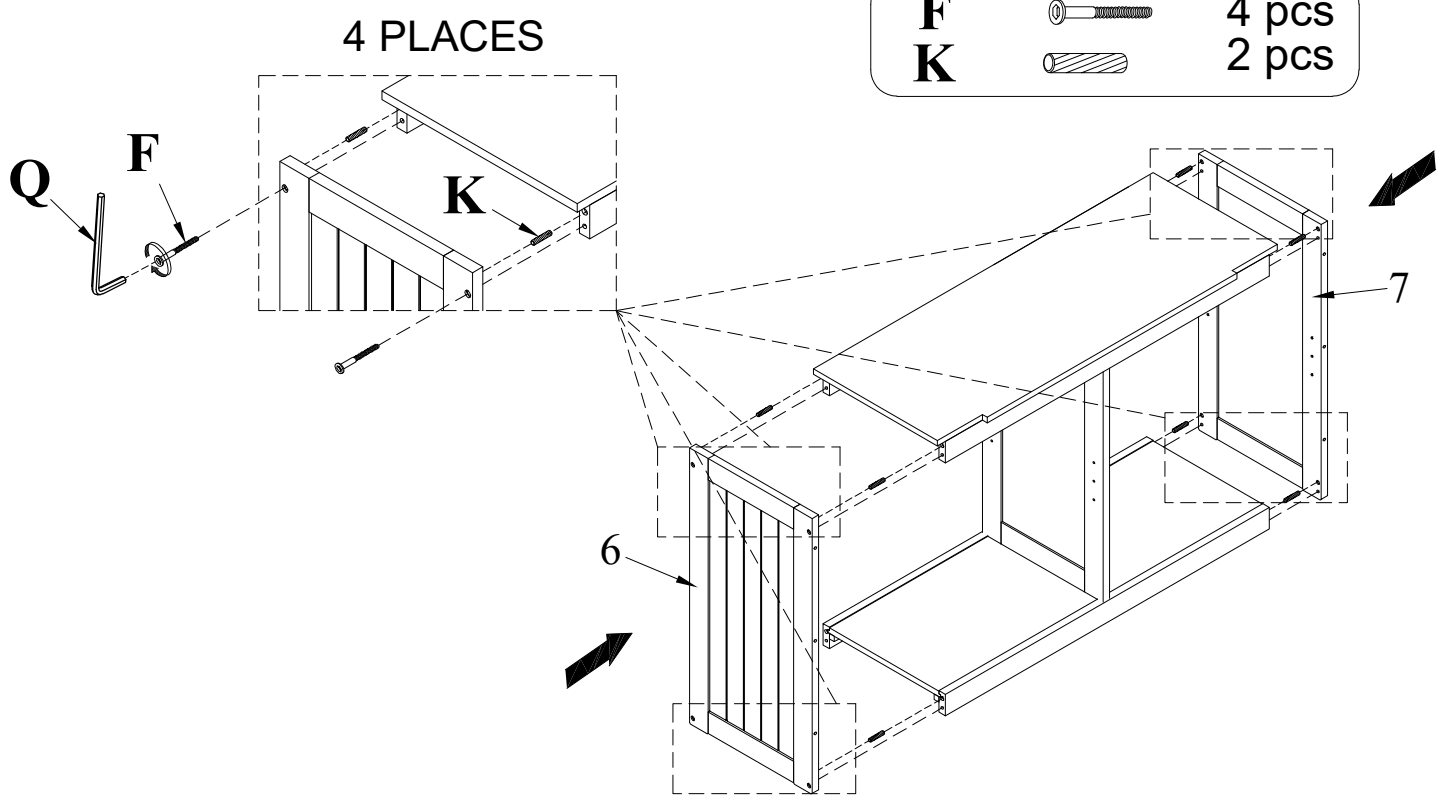

STEP 4:

F		4 pcs
K		2 pcs



STEP 5:

- | | | |
|----------|---|-------|
| N |  | 8 pcs |
| O |  | 8 pcs |

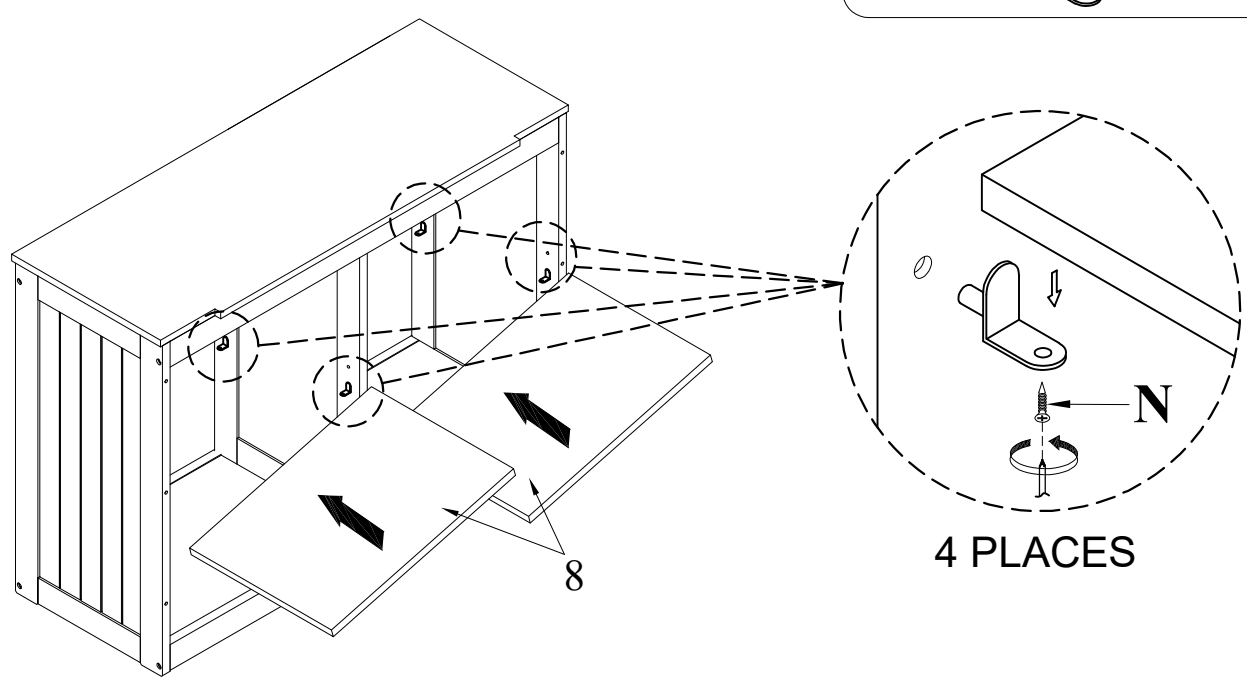

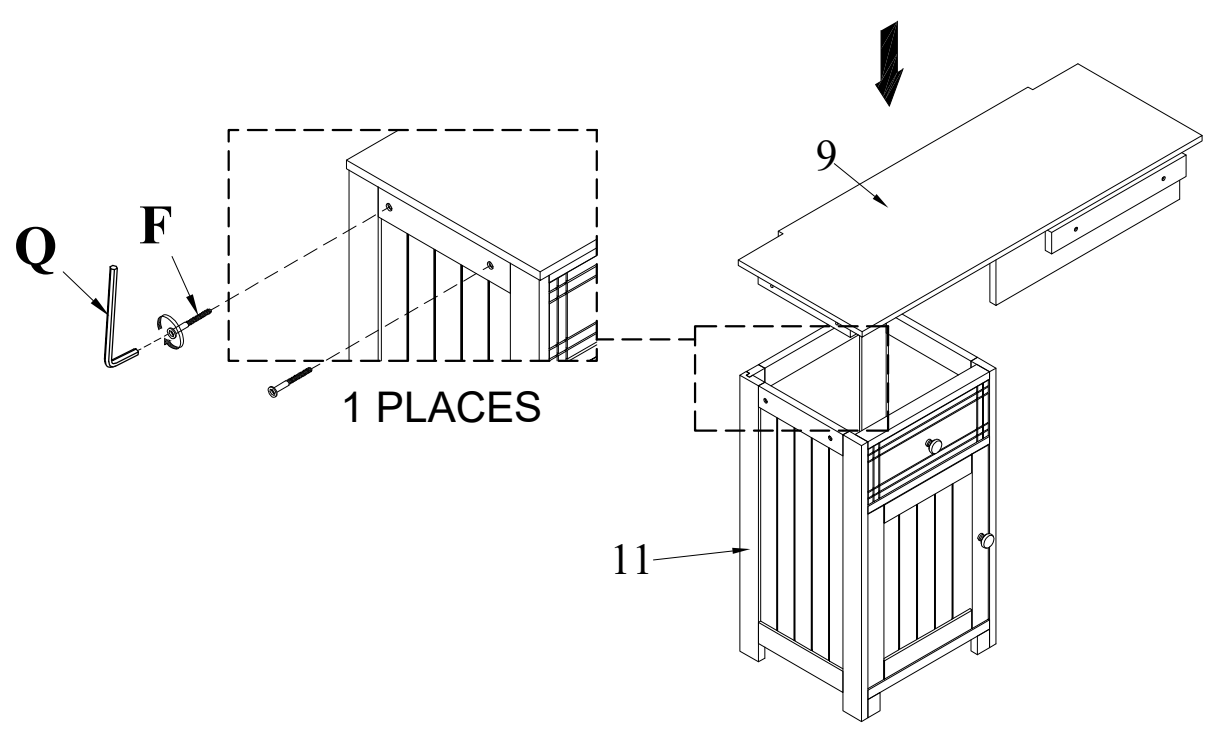

STEP 6:

- | | | |
|----------|---|-------|
| F |  | 4 pcs |
|----------|---|-------|



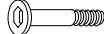
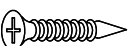

STEP 7:

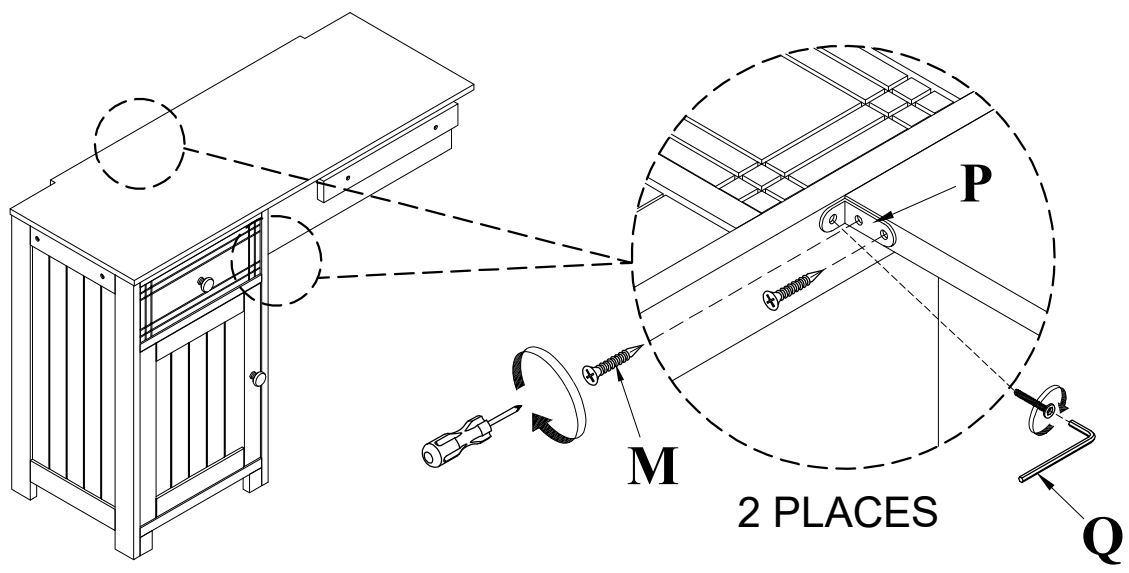
E		2 pcs
M		4 pcs
P		2 pcs



STEP 8:

A		2 pcs
C		2 pcs
D		2 pcs

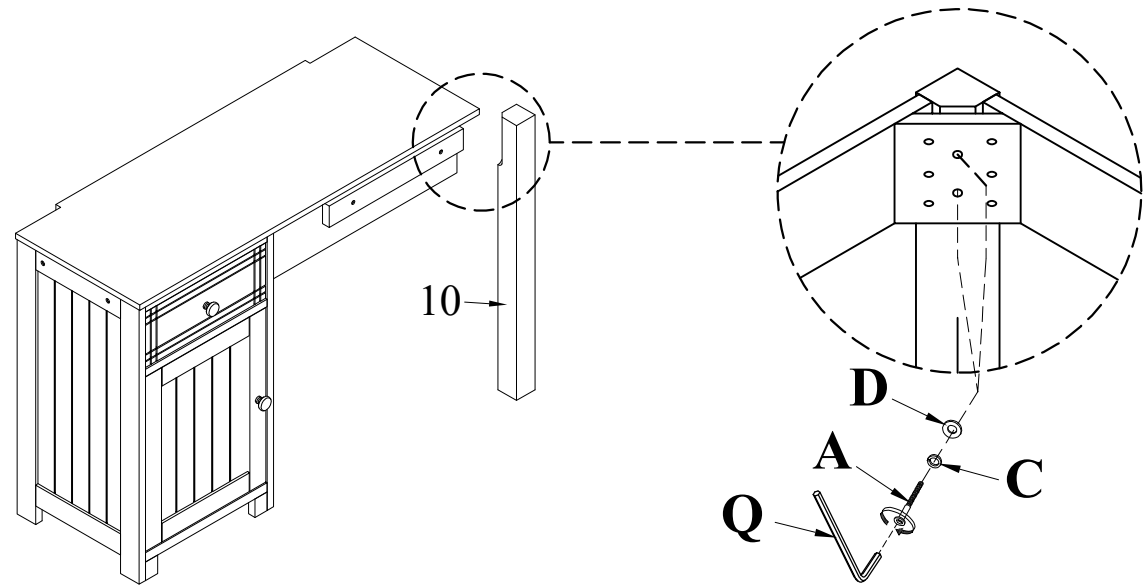

STEP 9:

F  4 pcs

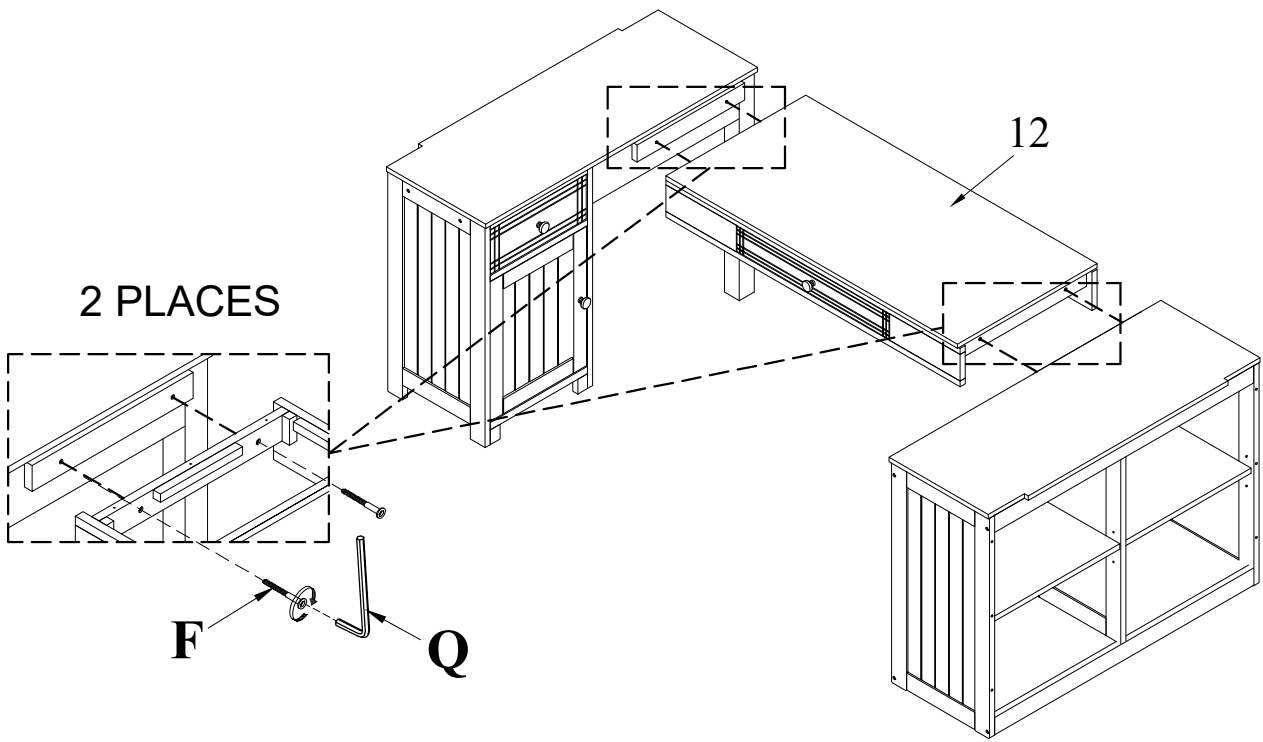

STEP 10:

H  5 pcs

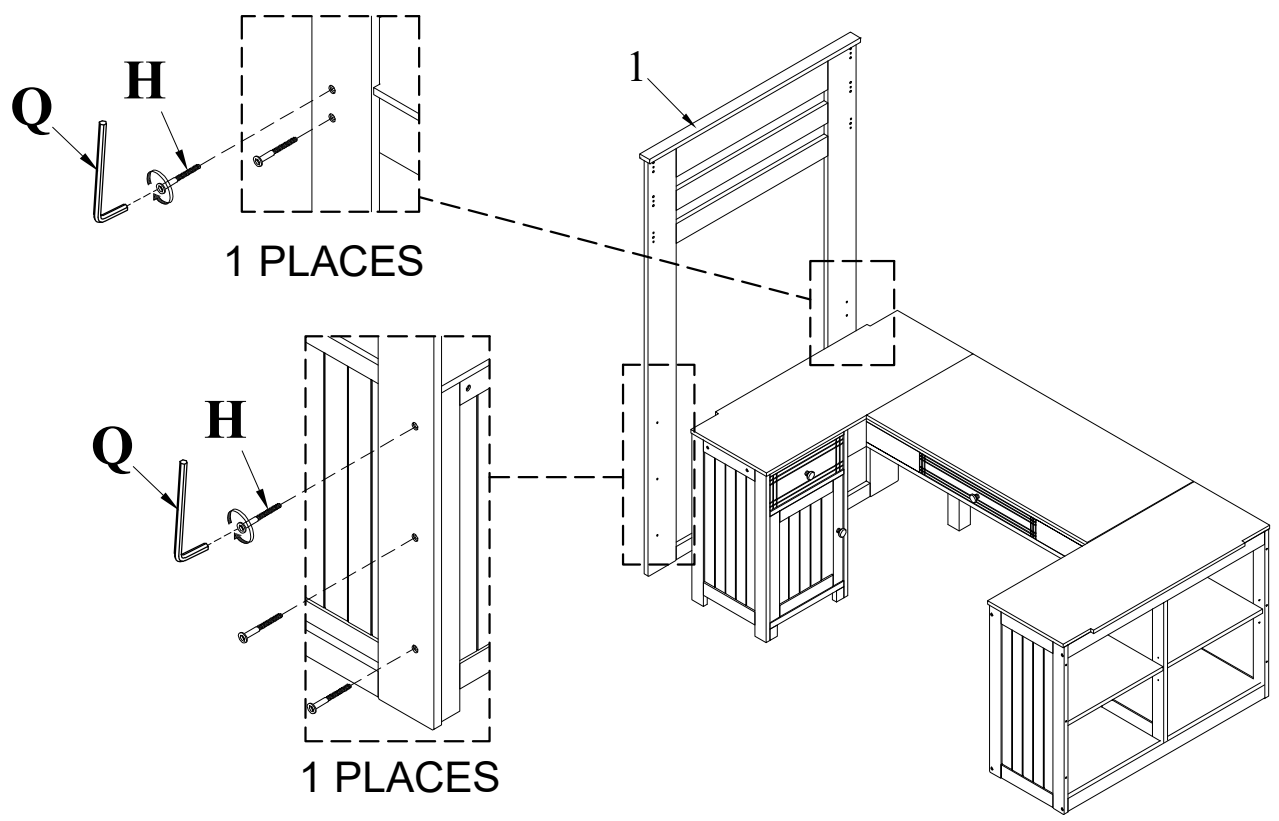

STEP 11:

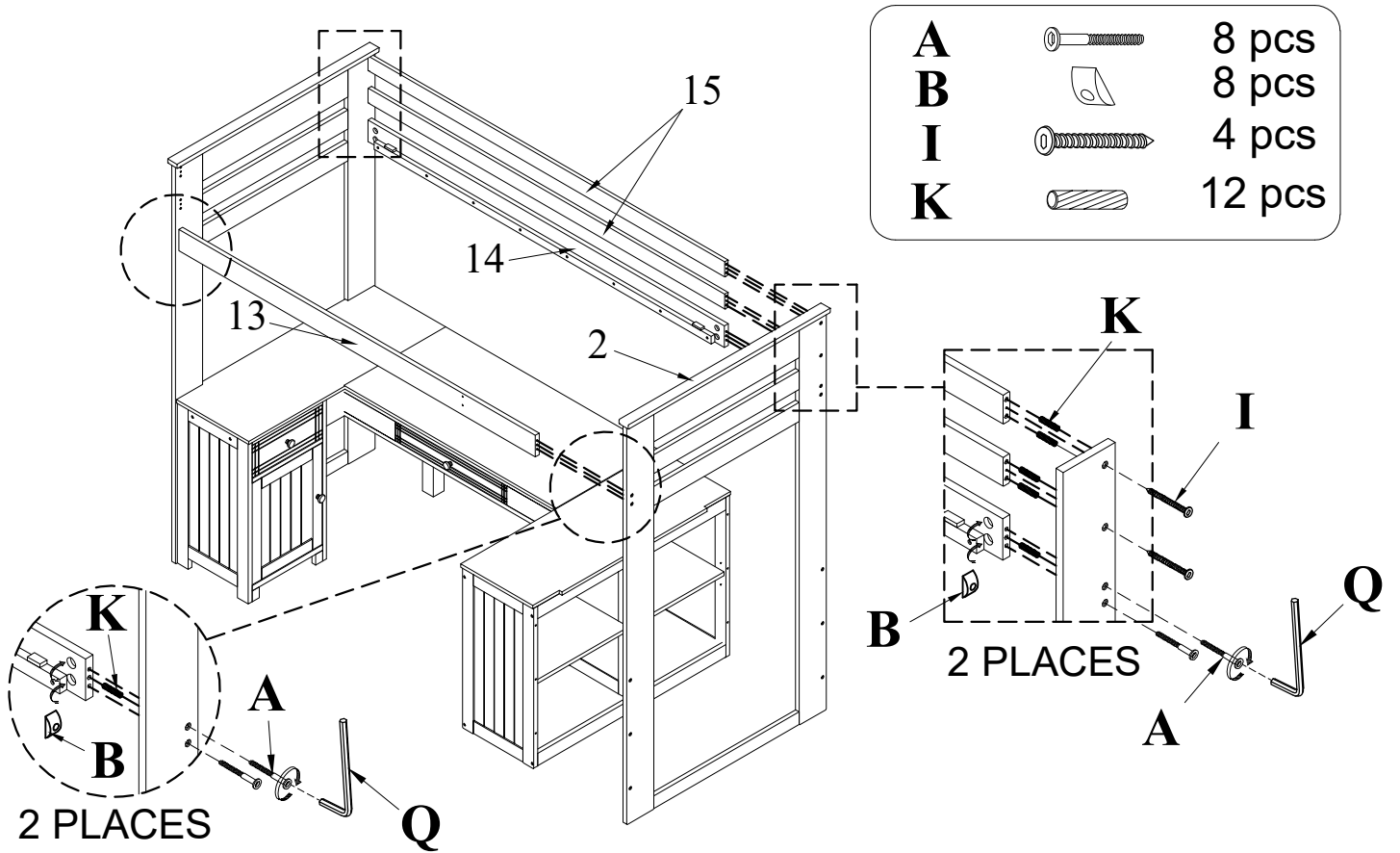

STEP 12:

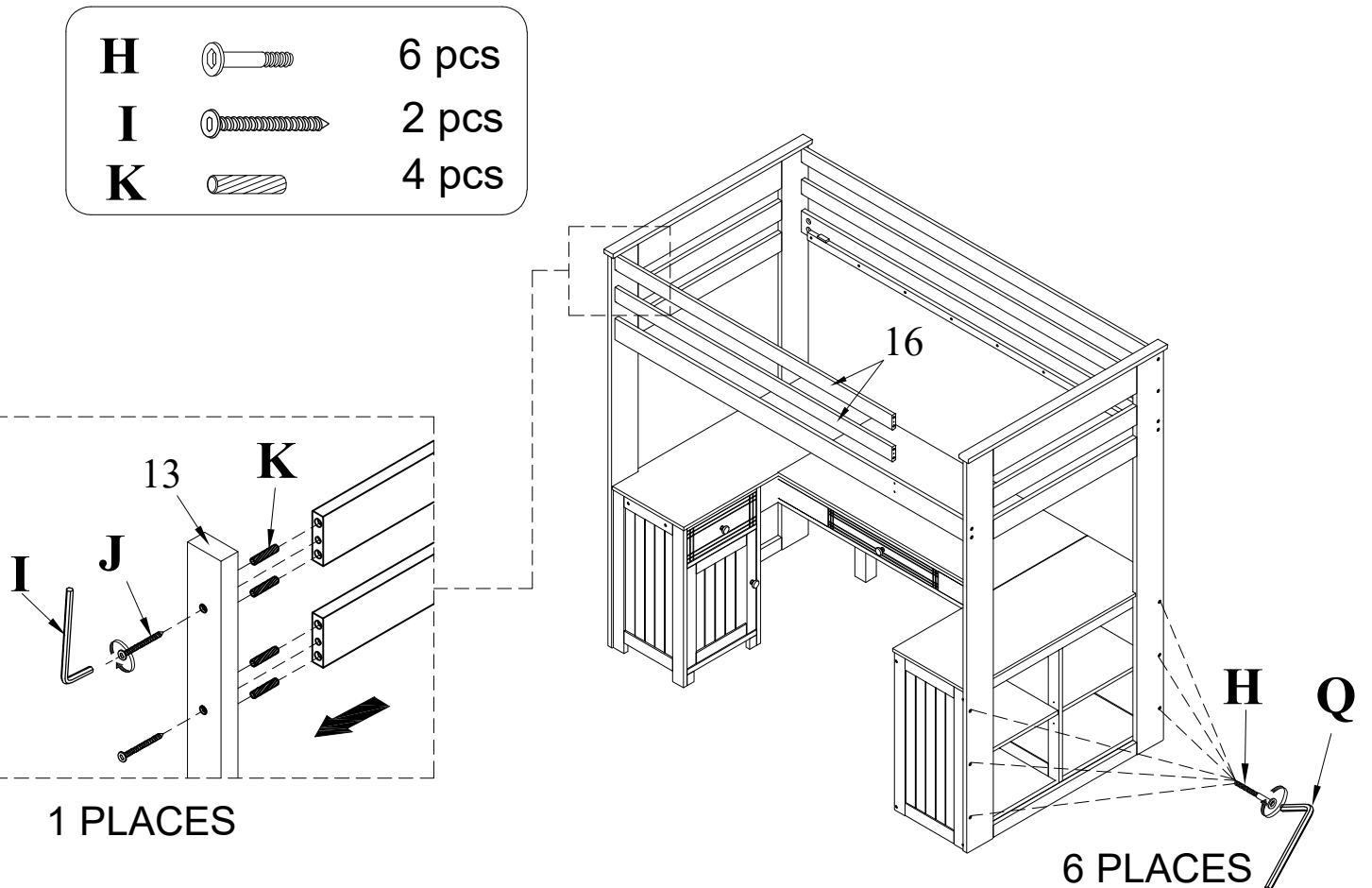

STEP 13: GUARDRAIL ATTACHMENT ASSEMBLY

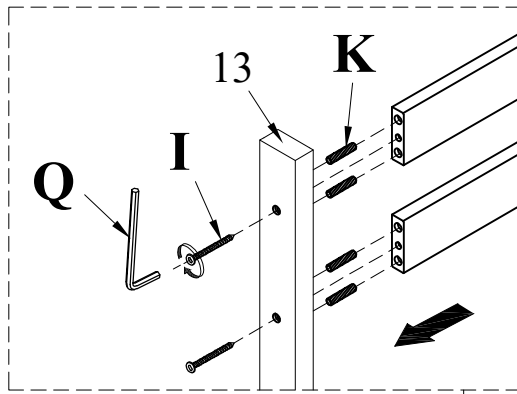

G		1 pcs
I		2 pcs
K		4 pcs
F		1 pcs

1 PLACES

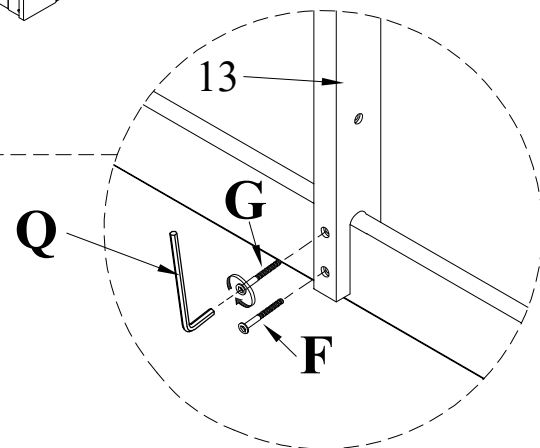
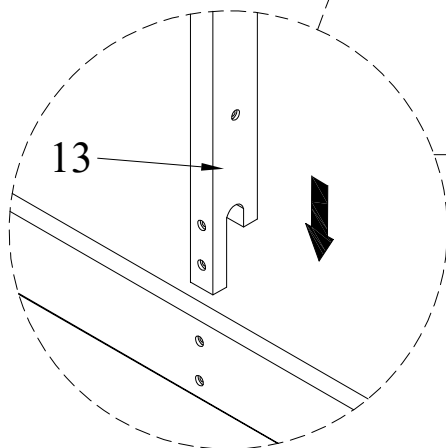
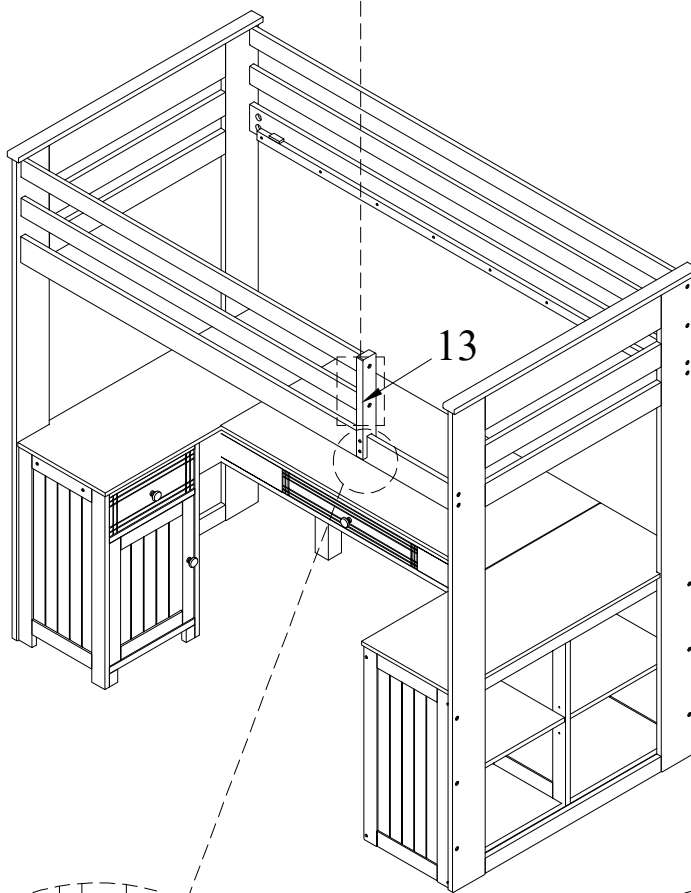

1 PLACES

STEP 14: GUARDRAIL SUPPORT ASSEMBLY

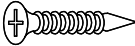
L  6 pcs

6 PLACES

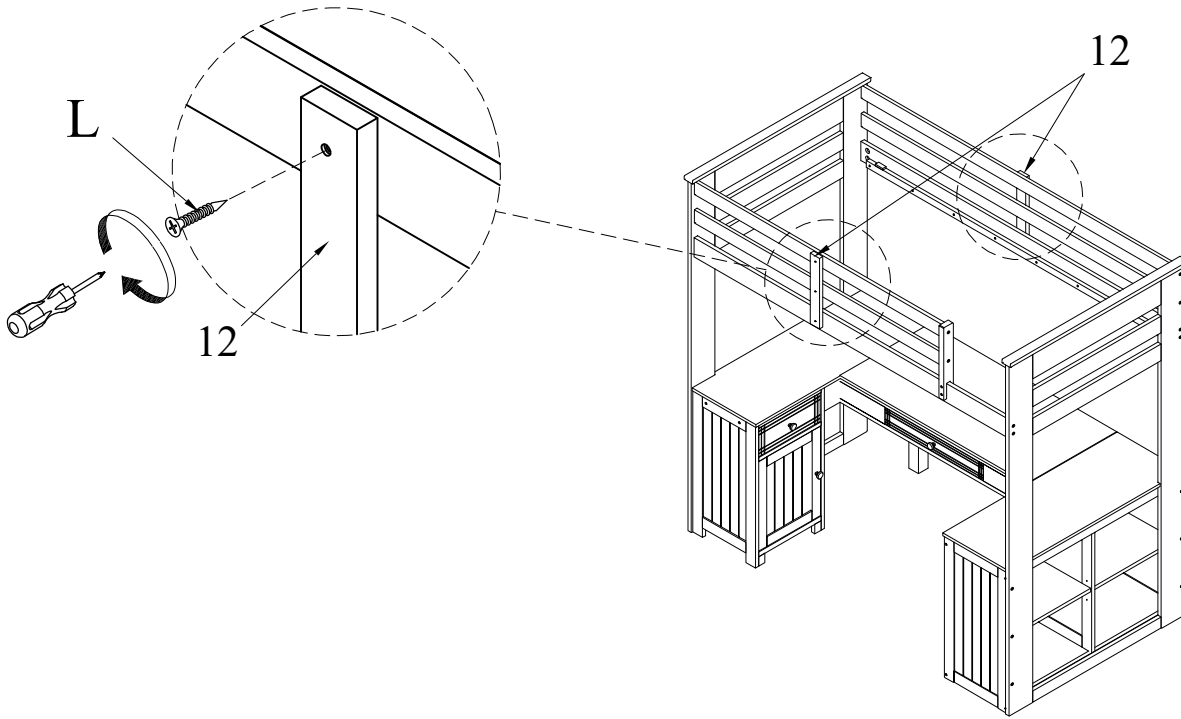

STEP 15: LADDER ASSEMBLY

J  10 pcs

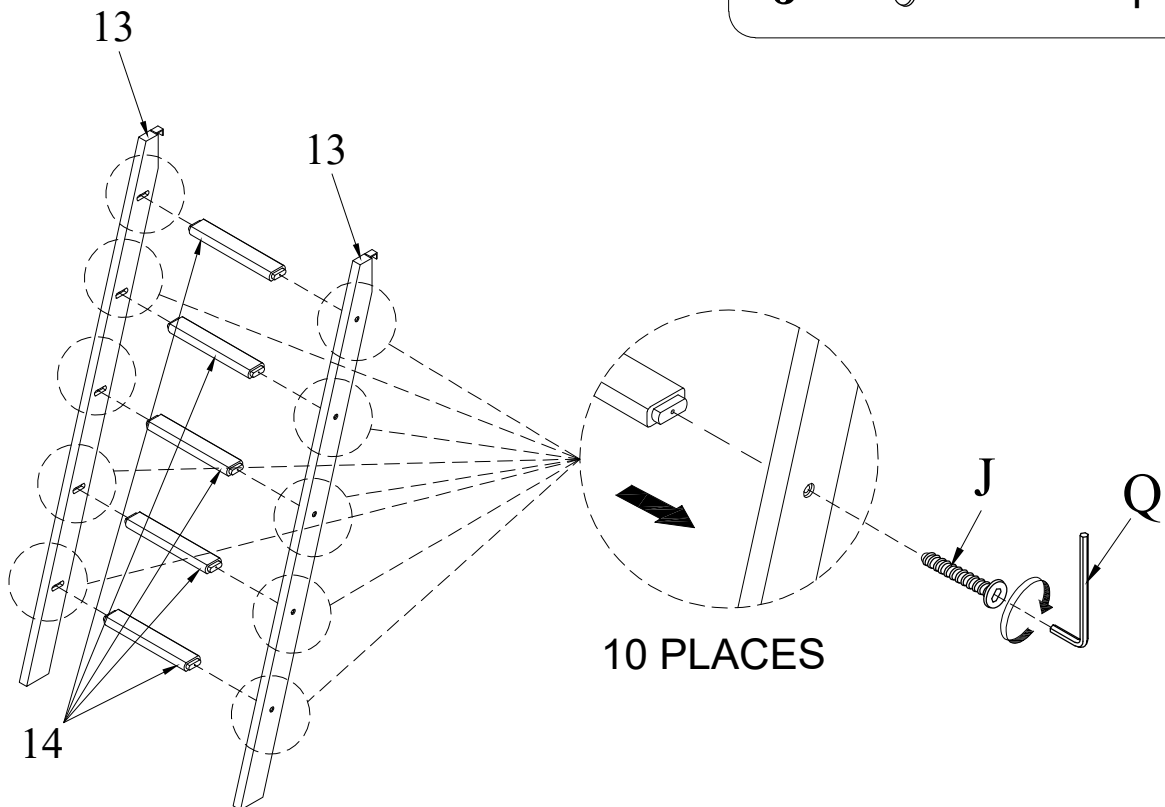

10 PLACES

STEP 16: COMPLETED LADDER ASSEMBLY

M  2 pcs

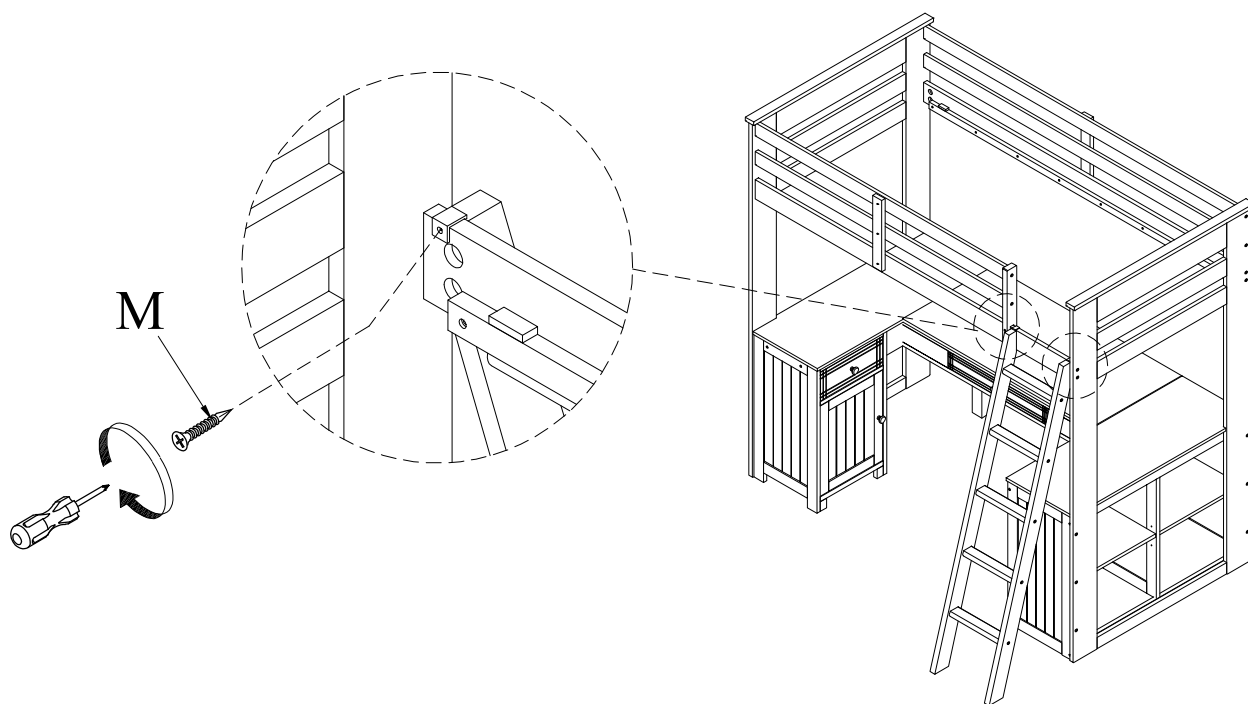

STEP 17: COMPLETED TWIN SLAT ASSEMBLY

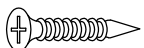
L  28 pcs

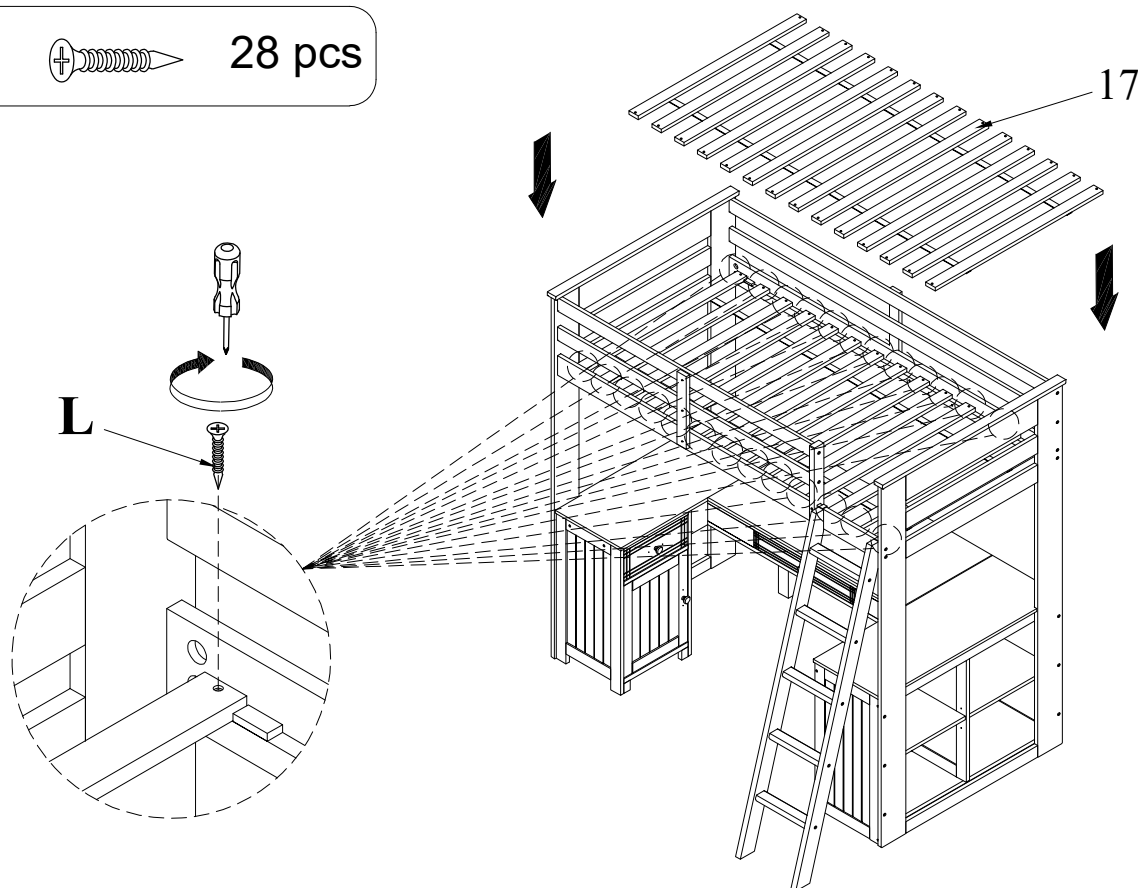

STEP 18:

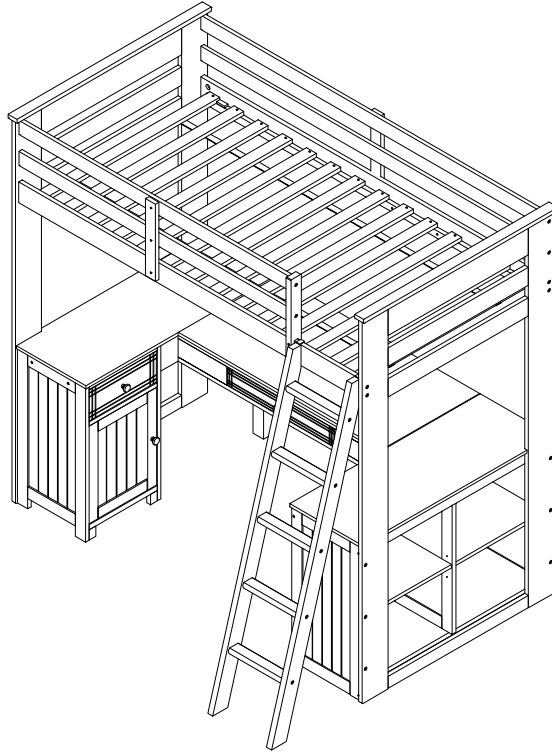

ASSEMBLY IS COMPLETED

WARNING !!!

To help prevent serious or fatal injuries from entrapment or falls:

1. Follow the information on the warning label appearing on the upper bunk end structure and on the carton. Do not remove warning label from bed.
2. Use only mattress which is 39" WIDE AND 75" LONG ON UPPER BUNK.
3. Ensure thickness of upper mattress does not exceed 6" and top surface of mattress is at least 5" below the upper edge of guardrails.
4. Do not allow children under 6 years to use the upper bunk.
5. Periodically check and ensure that the guardrail, ladder, and other components are in their proper position, free from damage, and that all connectors are tight.
6. Do not allow horseplay on or under the bed and prohibit jumping on the bed.
7. Always use ladder for entering and leaving upper bunk.
8. Do not use substitute parts. Contact the manufacturer or dealer for replacement parts.
9. Use of a night-light may provide added safety precaution for a child using the upper bunk.
10. Always use guardrails on both long sides of the upper bunk. If the bunk bed will be placed next to a-wall, the guardrail that runs the full length of the bed should be placed against the wall to prevent entrapment between the bed and the wall.
11. The use of water or sleep flotation mattresses is prohibited.

STRANGULATION HAZARD:

12. Never attach or hang items to any part of the bunk bed that are not designed for use with the bed, for example, but not limited to, hooks, belts and jump ropes.
13. Prohibit more than one person on upper bunk.
14. Maximum total weight not to exceed-150 lbs on the upper bunk, and maximum 200 lbs on lower bunk.
15. Keep these instructions for future reference.