

ASSEMBLY
REQUIREMENTS

2 Hours
Assembly Time
(Approximate)

1-Person
Assembly

Tools Required:
(Not Provided)

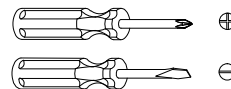

Thank you for purchasing our product!

Please refer and use this assembly instruction to assemble the product. Contact our customer service department in case there are any missing or damage parts or hardware. Replacement parts are normally shipped within 2 or 3 days.

PRODUCTS PURCHASED THROUGH OUR
AUTHORIZED VENDORS ONLY ARE ELIGIBLE
FOR REPLACEMENT PARTS.

We appreciate your business!

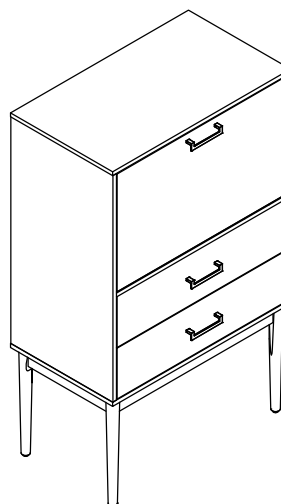

ASSEMBLY PREPARATION

1. Remove all packaging materials, staples and packing straps from the carton.
2. Refer to Parts List and Hardware List, and ensure parts and hardware are correct before assembly.
Contact customer service for missing parts.
3. Place all wooden parts on a clean, flat and soft surface (e.g. carpet or rug) to prevent scratch and damage to parts.

SAFETY PRECAUTION

1. KEEP ALL HARDWARE PARTS OUT OF REACH OF CHILDREN.
2. DISPOSE PLASTIC PACKAGING MATERIAL IMMEDIATELY TO AVOID ANY RISK OF SUFFOCATION TO CHILDREN AND ANIMALS.

TIPS FOR ASSEMBLY

1. Allow ample room for assembly and assemble the product near where the product will be placed.
2. Assemble the product on a surface that does not scratch or damage the exterior gloss and finish of the furniture.
3. Identify all of the parts, hardware and quantities required for each step.
4. During assembly, do not over-tighten any fittings as this may cause damage.
5. DO NOT USE POWER TOOLS TO ASSEMBLE THIS PRODUCT.
6. Always place the product on a flat, level surface.
7. Do not sit or stand on the partially assembled product; only use the product for which it is intended.

CARE AND MAINTENANCE

- Use a slightly damp cloth to clean the product. Do not use bleach or abrasive cleaning material.
- Check all the fittings periodically and re-tighten as necessary. Do not use the product if any of the parts is damaged or broken.
- Never allow any kind of liquid to remain on your furniture. Absorption can cause wood to warp or delaminate.
- Do not place hot items (e.g. hot drinks) directly onto the wood surface.
- Do not drag and/or pull the furniture.

This product is for indoor and household use only - not for commercial use.

ASSEMBLY INSTRUCTIONS

TALL BAR CABINET

PARTS LIST

NO.	PART NAME	QTY	NO.	PART NAME	QTY
(A)	Top Panel	1	(H)	Drawer Front Panel	2
(B)	Bottom Panel	1	(I)	Drawer Left Panel	2
(C)	Left Panel	1	(J)	Drawer Right Panel	2
(D)	Right Panel	1	(K)	Drawer Back Panel	2
(E)	Shelf Panel	1	(L)	Drawer Bottom Panel	2
(F)	Top Flap	1	(M)	Leg	4
(G)	Upper Back Panel	1	(N)	Bottom Bar	2
(O)	Lower Back Panel	1			



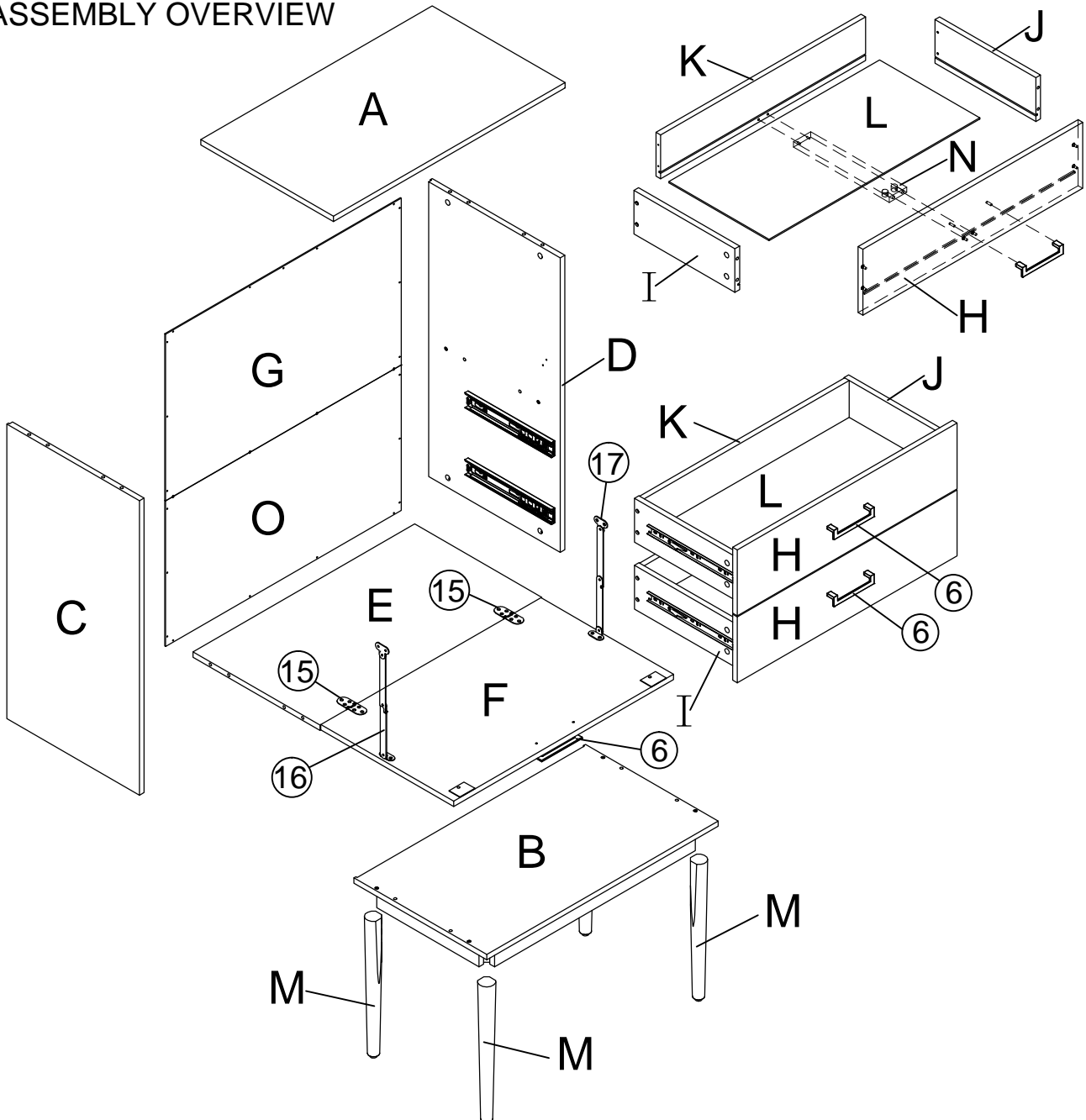





ASSEMBLY OVERVIEW

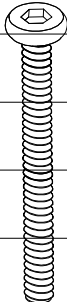
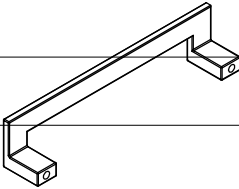
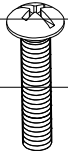
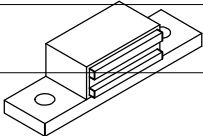
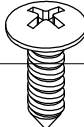

ASSEMBLY INSTRUCTIONS

TALL BAR CABINET

HARDWARE LIST

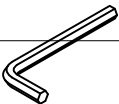
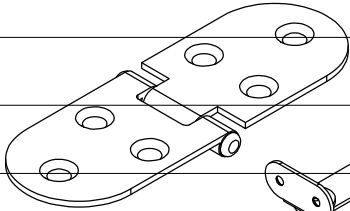
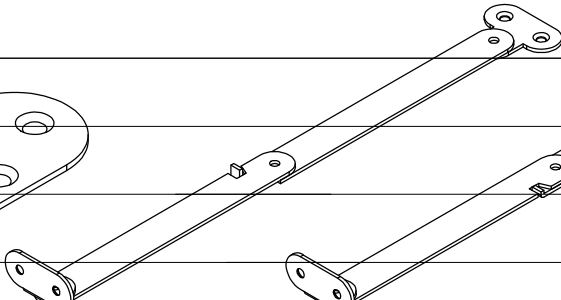
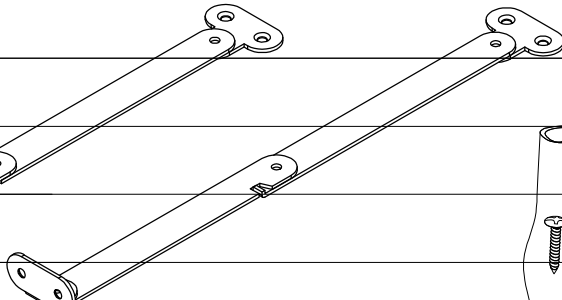
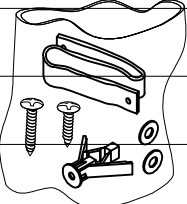
							4CM
24X ø6*35mm 1	12X ø8*30mm 2	24X ø15*9mm 3	12X ø3*30mm 4	8X ø1/4"*45mm 5	3X 140*28.5*24mm 6	6X ø5/32"*20mm 7	3CM
Cam-bolt	Wood Dowel	Cam-lock	Screw	Screw	Handle	Handle Bolt	2CM
							1CM
2X 45*12mm 8	8X ø4*15mm 9	8X ø1/4" 10	8X ø1/4" 11	12X ø3.5*12mm 12	28X ø3*15mm 13	1X 4mm 14	0CM
Door Magnet	Screw	Flat Washer	Spring Washer	Screw	Screw	Allen Wrench	5CM
							4CM
2X 90*31*1.5mm 15	1X 343*45*23.5mm 16	1X 343*45*23.5mm 17	1 SET 18				3CM
Hinge	Left Flap Hinge	Right Flap Hinge	Safety Strap Kit				2CM
							1CM
							0CM

EXTRA HARDWARE

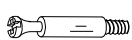

ø6*35mm
2PCS
Cam-bolt



ø15*9mm
2PCS
Cam-lock



ø8*30mm
2PCS
Wood Dowel

INSTRUCTIONS FOR CAM-BOLT & CAM-LOCK

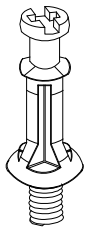

CAM-BOLT

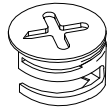

CAM-LOCK

Tools Required

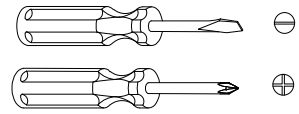

INSERTING AND TIGHTENING CAM-BOLT

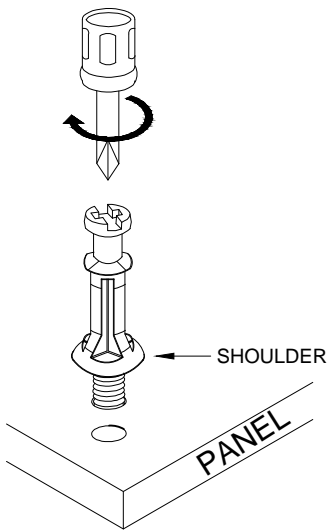

Place Cam-bolt on pre-drilled hole and screw in vertically

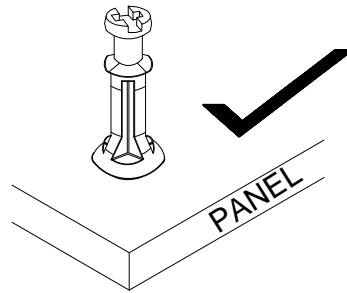

Shoulder is flushed (on the same level) with the panel.

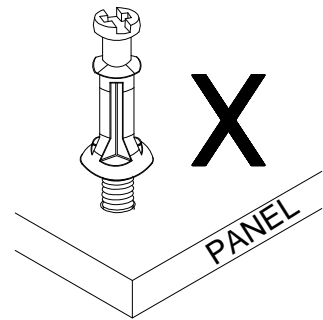

Shoulder is above the panel.

Place Cam-bolt on the designated pre-drilled holes on the panel. Use a Phillips Screwdriver to screw-in Cam-bolt vertically until shoulder is flushed (on the same level) with panel.

INSERTING AND TIGHTENING CAM-LOCK

INSERTING CAM-LOCK

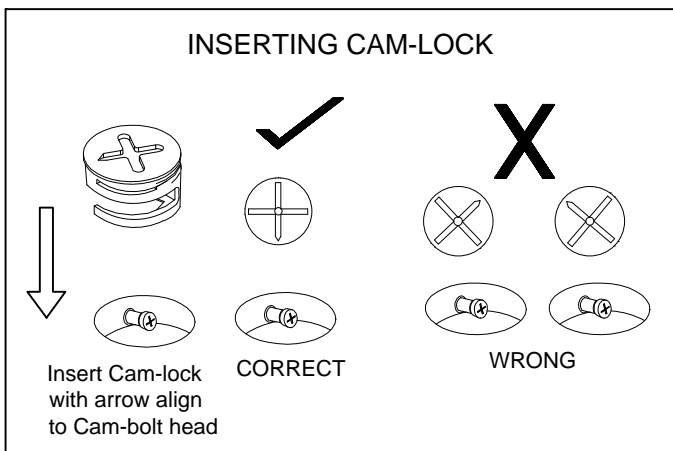

Align the arrow on the Cam-lock to the Cam-bolt head and insert the Cam-lock. Ensure Cam-lock is fully inserted.

TIGHTENING CAM-LOCK

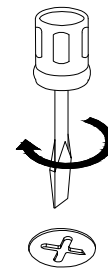

Use a Flat-head Screwdriver to turn Cam-lock clockwise so it locks onto the head of the Cam-bolt. Turn until it is snug (about 3/4ths of a turn) -- over-tightening could damage Cam-lock or/and Cam-bolt.

ASSEMBLY INSTRUCTIONS TALL BAR CABINET

STEP 1- Assemble Drawers

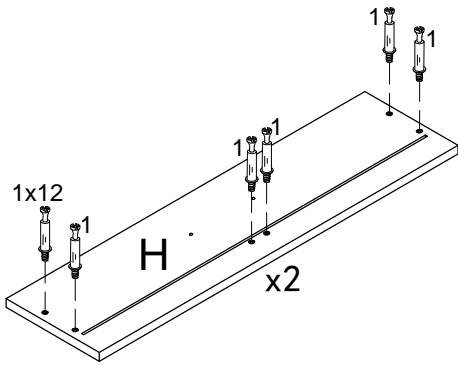

Step 1A:
Lay Drawer Front Panel (H) as shown on a material that does not scratch its exterior surface and screw in Cambolt (1) into designated holes. Refer to Page 4 for instructions to screw in and tighten Cam-bolt.

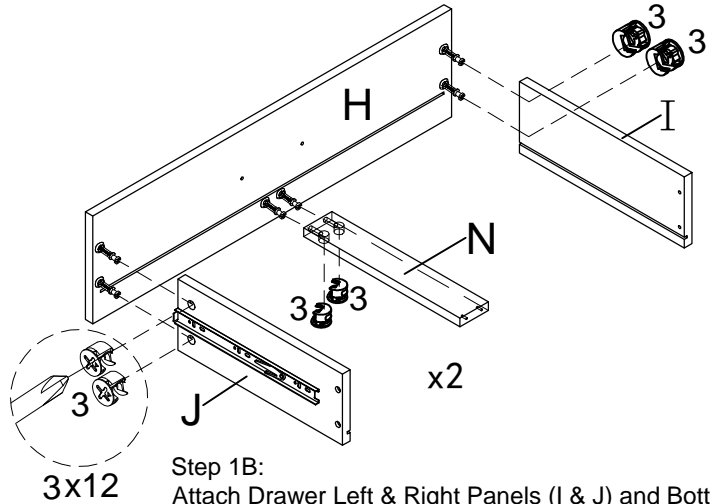

Step 1B:
Attach Drawer Left & Right Panels (I & J) and Bottom Bar (N) to Drawer Front Panel (H) via cam-bolt on (H) - note the groove on (I & J) is at the bottom. Next, insert Cam-lock (3) into designated holes on (I, J & N) and turn clockwise to lock onto cam-bolt. Refer to Page 4 for instructions to insert and tighten cam-lock.

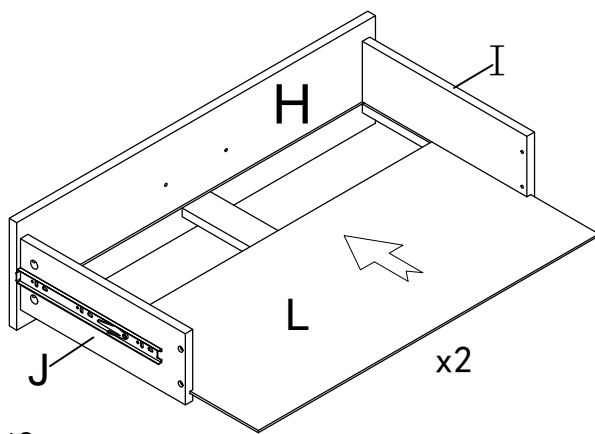

Step 1C:
Fit Drawer Bottom Panel (L) via groove on (I, J & H).

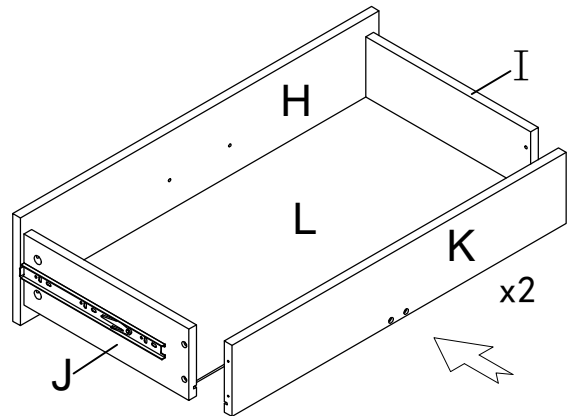



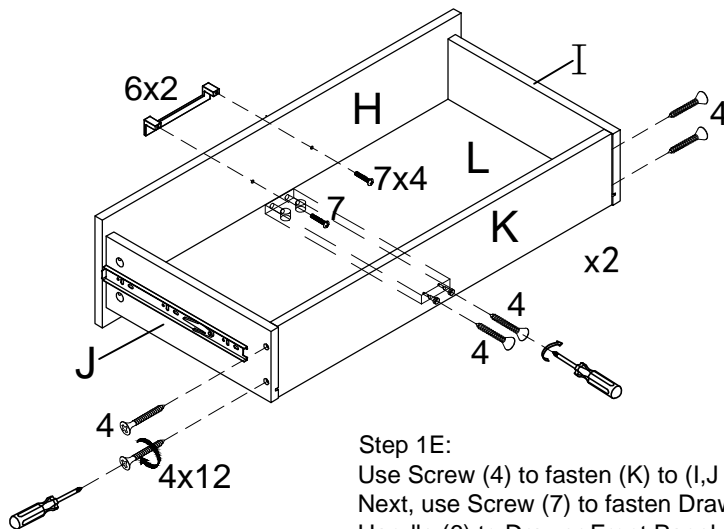

Step 1D:
Attach Drawer Back Panel (K) to side panels - check that the edge of (L) fits into the groove on (K).



Step 1E:
Use Screw (4) to fasten (K) to (I, J & N). Next, use Screw (7) to fasten Drawer Handle (6) to Drawer Front Panel (H).

The assembly of the drawer is complete.

①		12PCS
③		12PCS
④		12PCS
⑥		2PCS
⑦		4PCS

ASSEMBLY INSTRUCTIONS

TALL BAR CABINET

STEP 2

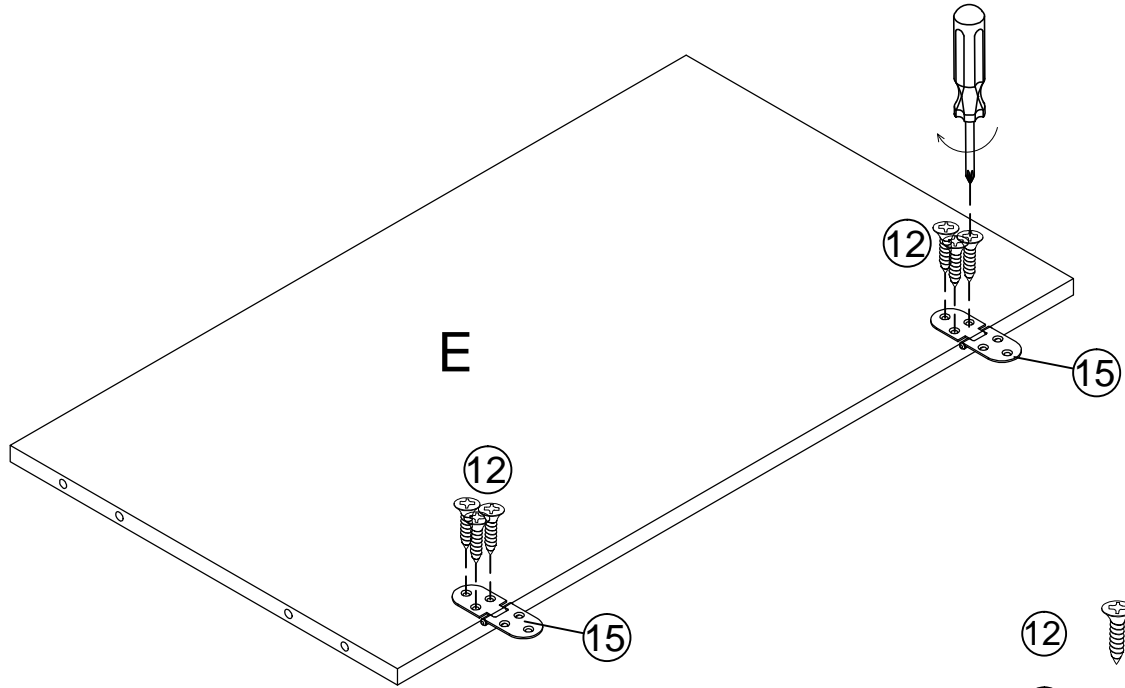

Lay Shelf Panel (E) as shown on a material that does not scratch its exterior surface and use Screw (12) to fasten Hinge (15) to (E).

- ⑫ 6PCS
- ⑮ 2PCS

STEP 3

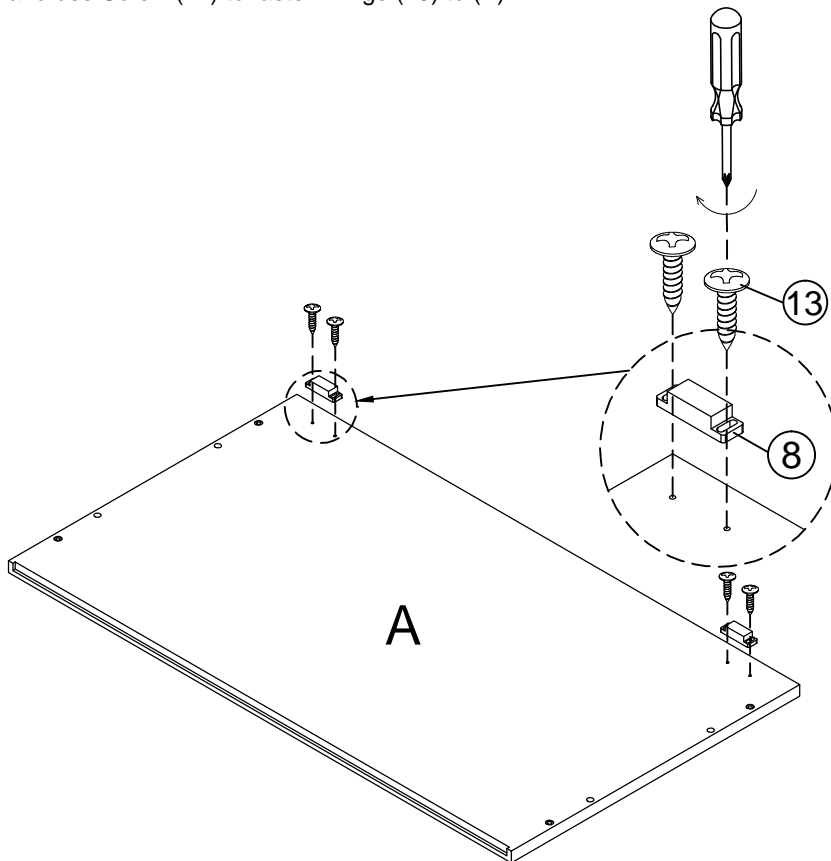

Lay Top Panel (A) bottom-side upon a material that does not scratch its exterior surface and use Screw (13) to fasten Door Magnet (8) to (A) as shown.

- ⑧ 2PCS
- ⑬ 4PCS

ASSEMBLY INSTRUCTIONS

TALL BAR CABINET

STEP 4

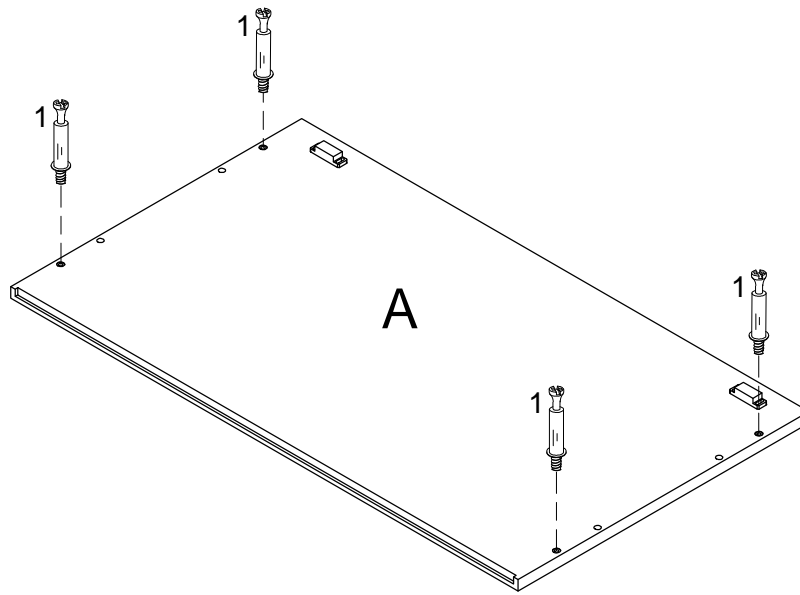

Screw in Cam-bolt (1) into designated holes on bottom-side of Top Panel (A).

STEP 5

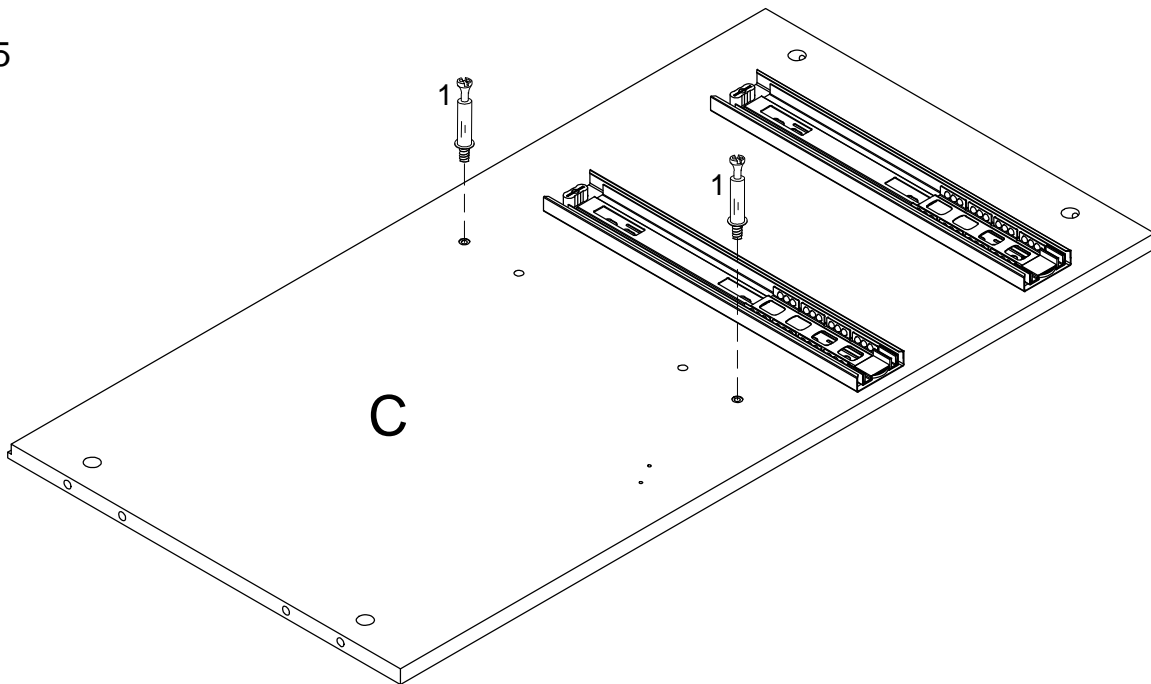

Lay Left Panel (C) on a material that does not scratch its exterior surface and screw in Cam-bolt (1) into designated holes as shown.



ASSEMBLY INSTRUCTIONS TALL BAR CABINET

STEP 6

Lay Right Panel (D) on a material that does not scratch its exterior surface and screw in Cam-bolt (1) into designated holes as shown.

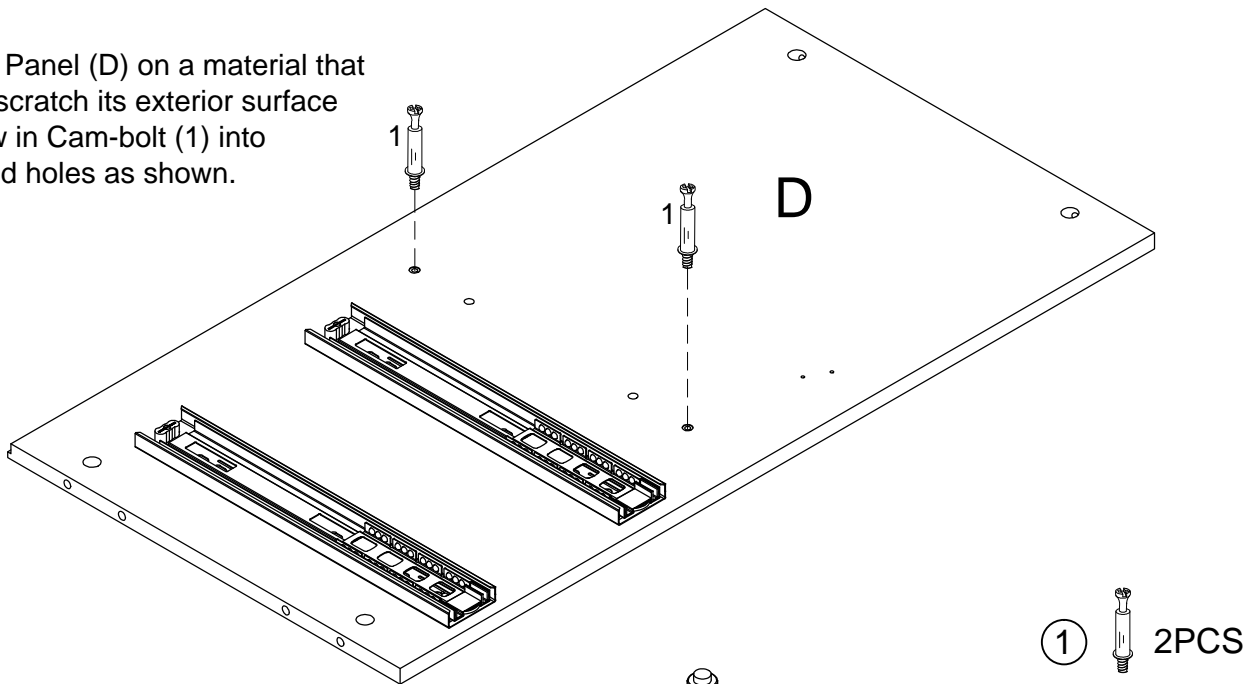

STEP 7

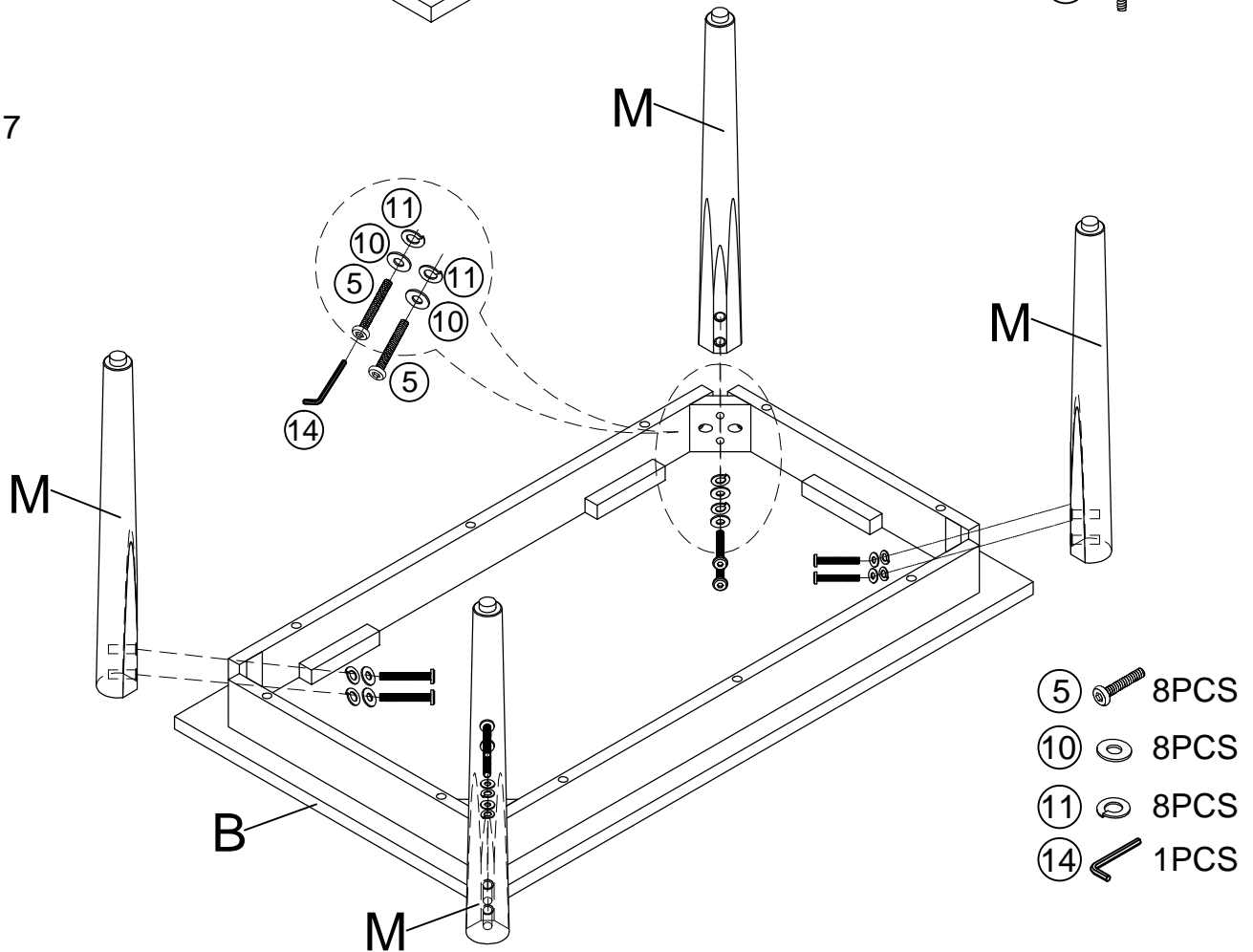

- a) Lay Bottom Panel (B) bottom-side up on a material that does not scratch its exterior surface.
- b) Position Leg (M) against the corner of the aprons and align the screw holes on (M) and the corner block.
- c) Use Screw (5) fitted with Flat Washer (10) and Spring Washer (11) to fasten (M) to corner block. Use Allen Key (14) to drive and tighten (5). Do not tighten (5) completely until both screws are in place.

ASSEMBLY INSTRUCTIONS TALL BAR CABINET

STEP 8

With assistance set assembly from STEP 9 right-side up and screw in Cam-bolt (1) into the designated holes as shown.

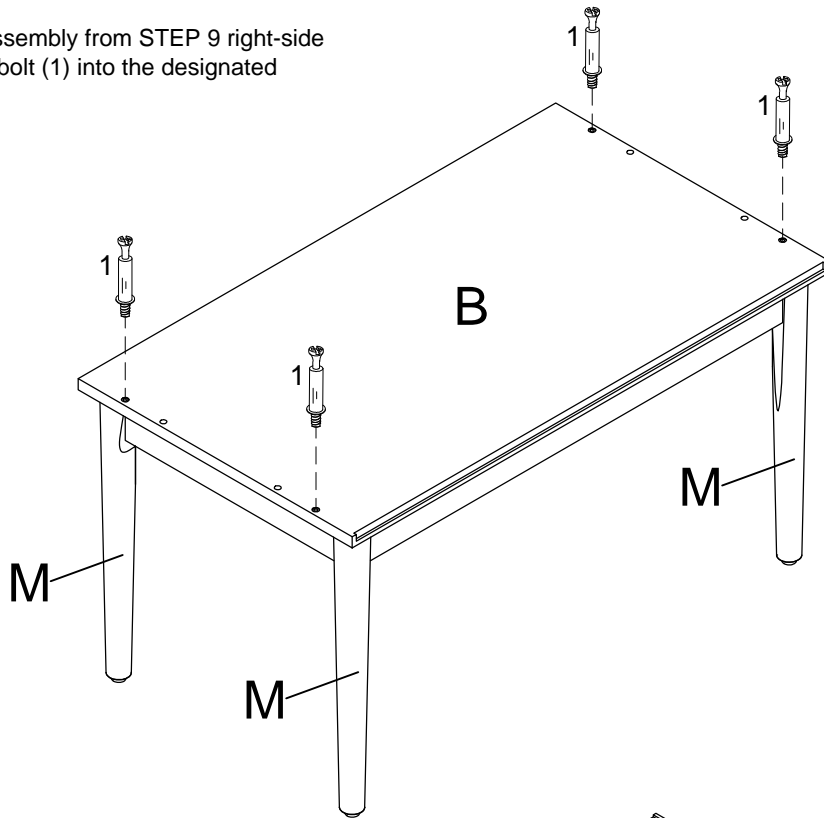

STEP 9

- a) With assistance position Shelf Panel (E), Left & Right Panel (C & D) from STEP 2, STEP 5 and STEP 6, respectively as shown.
- b) Insert Wood Dowel (2) into the designated holes on (C & D).
- c) Attach (C & D) to (E) via wood dowel and cam-bolt.
- d) Insert Cam-lock (3) into the designated holes on the bottom-side of (E) and turn clockwise to lock onto cam-bolt.

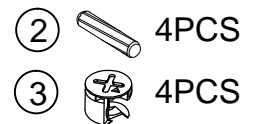
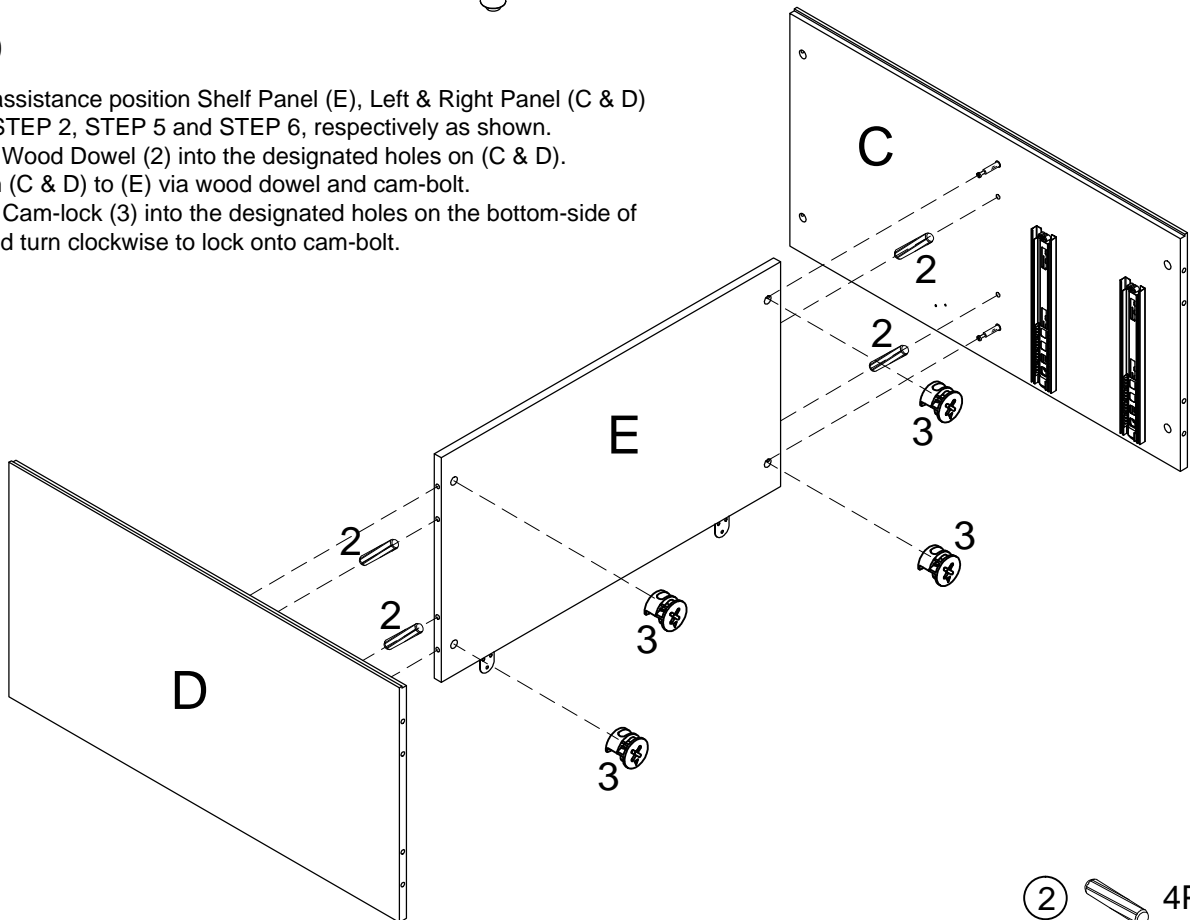

ASSEMBLY INSTRUCTIONS TALL BAR CABINET

STEP 10

- Insert Wood Dowel (2) into the designated holes on Bottom Panel (B) from STEP 8 as shown.
- With assistance attach assembly from STEP 9 to (B) via wood dowel and cam-bolt on (B).
- Insert Cam-lock (3) into the designated holes near the bottom edge of (C & D) and turn clockwise to lock onto cam-bolt.

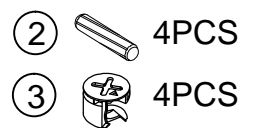
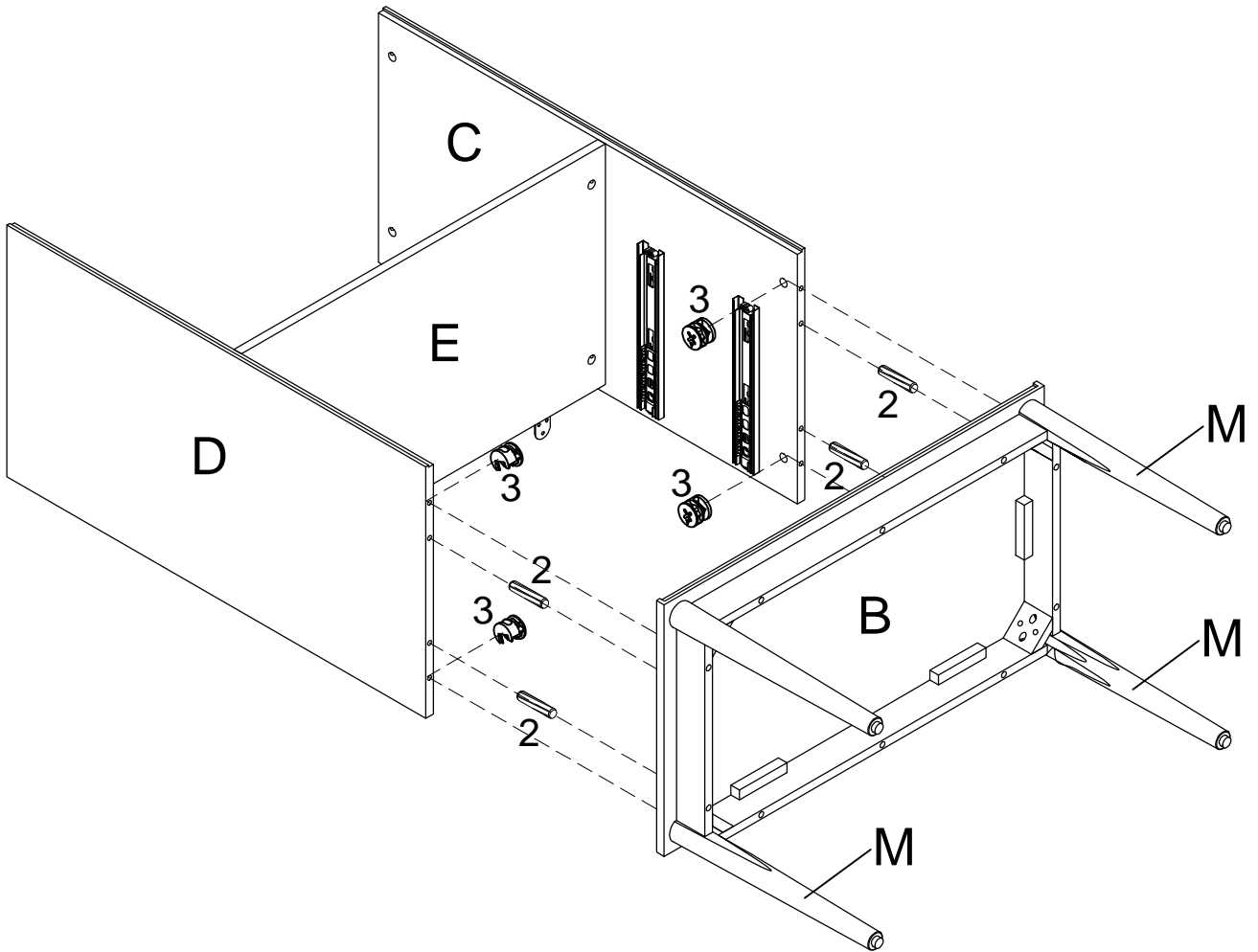



ASSEMBLY INSTRUCTIONS TALL BAR CABINET

STEP 11

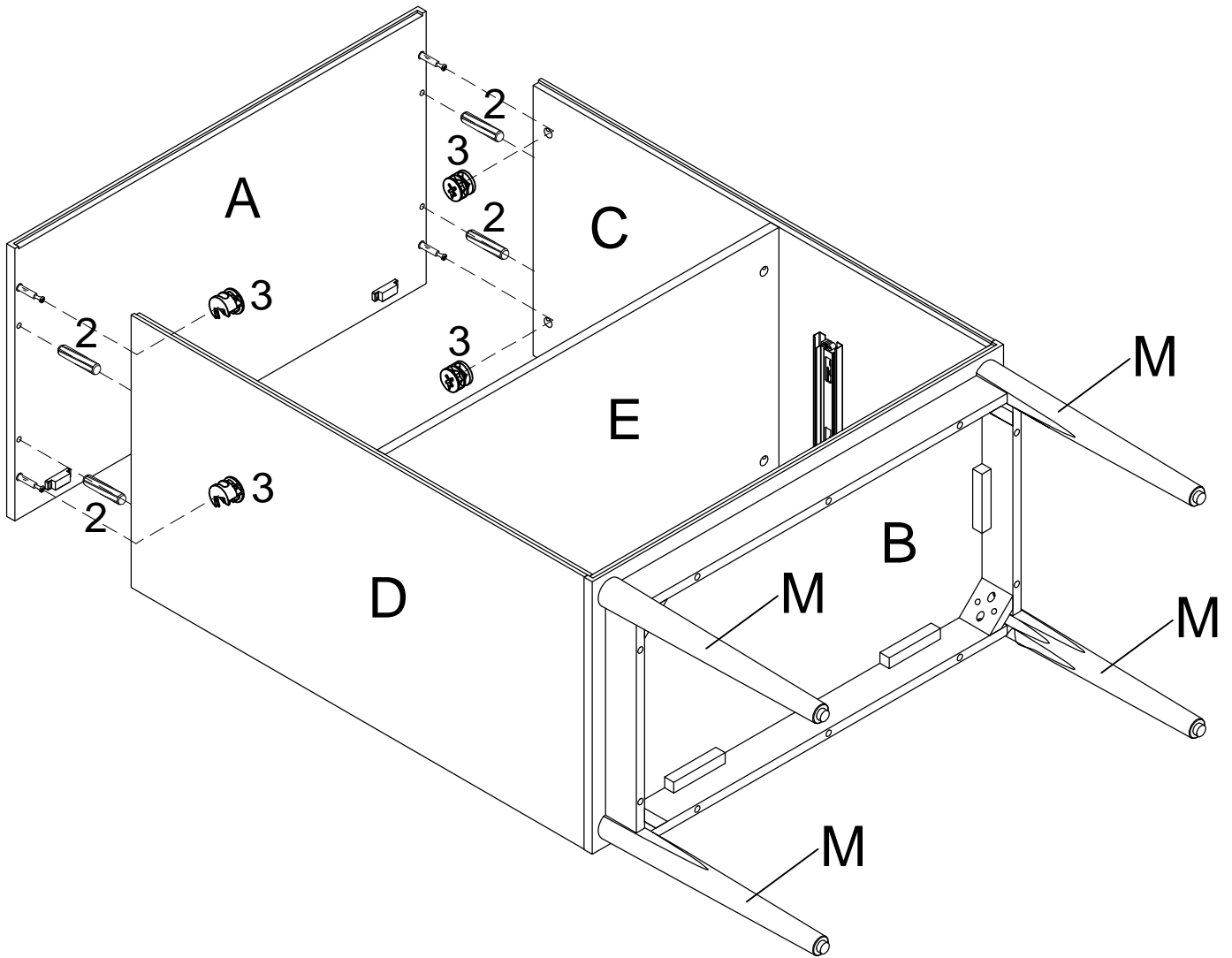
- Insert Wood Dowel (2) into the designated holes on the top edge of Side Panel (C & D) as shown.
- With assistance attach Top Panel (A) from STEP 4 to (C & D) via cam-bolt and wood dowel on the respective parts. Check that the front edge of (A) with the Door Magnet is in front (mirror the Hinge on Shelf (E)).
- Insert Cam-lock (3) into the designated holes on (C & D) and turn clockwise to lock onto cam-bolt.



- | | | |
|---|---|------|
| ② |  | 4PCS |
| ③ |  | 4PCS |

ASSEMBLY INSTRUCTIONS

TALL BAR CABINET

STEP 12

With assistance, fit Back Panel (G & O) squarely to the back edge of Side, Top and Bottom Panel and fasten with Screw (13).

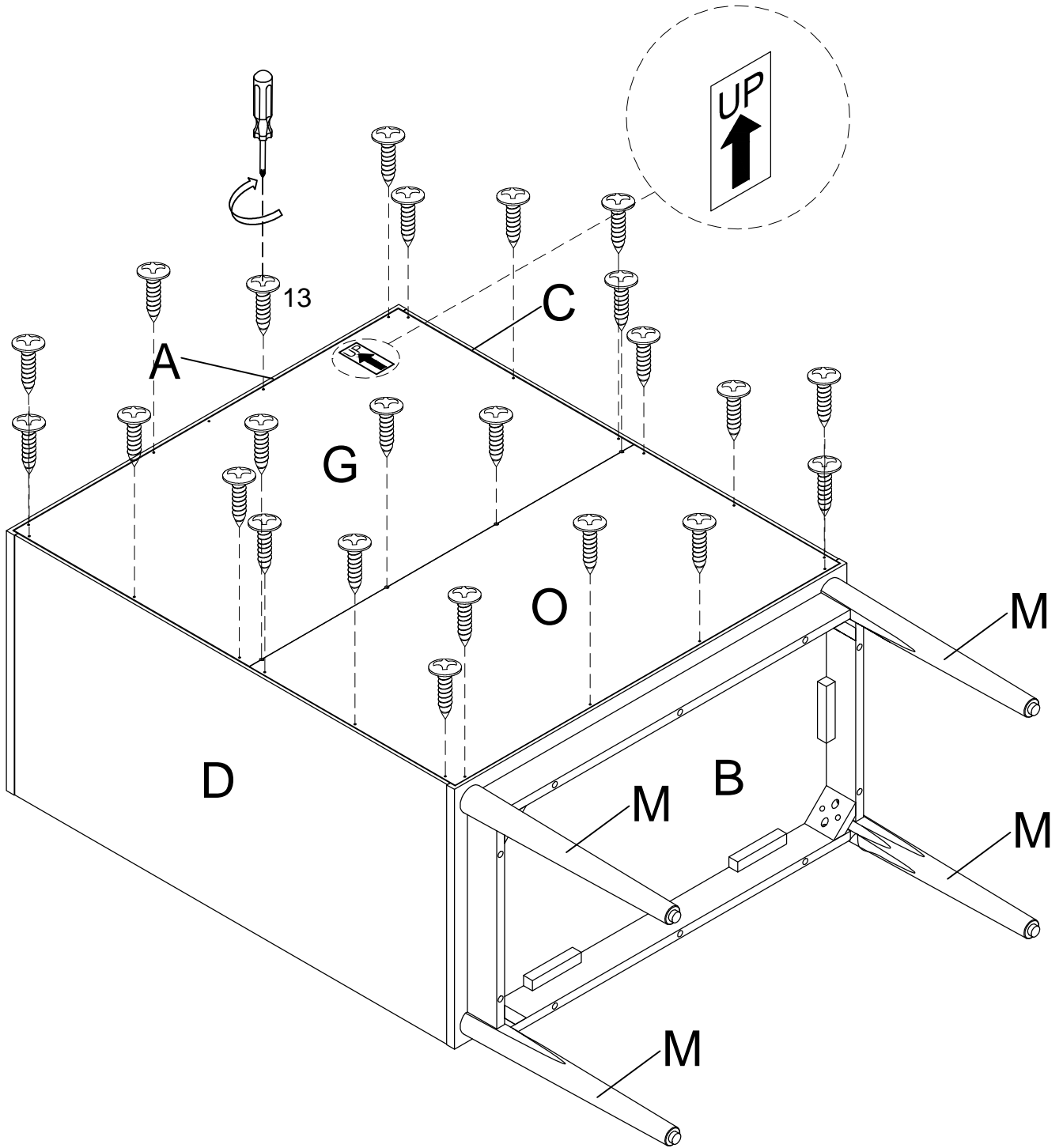

⑬  24PCS

ASSEMBLY INSTRUCTIONS
TALL BAR CABINET

STEP 13

Position Left Flap Hinge (16) as shown and use Screw (9) to fasten (16) into designated holes on Left Panel (C).

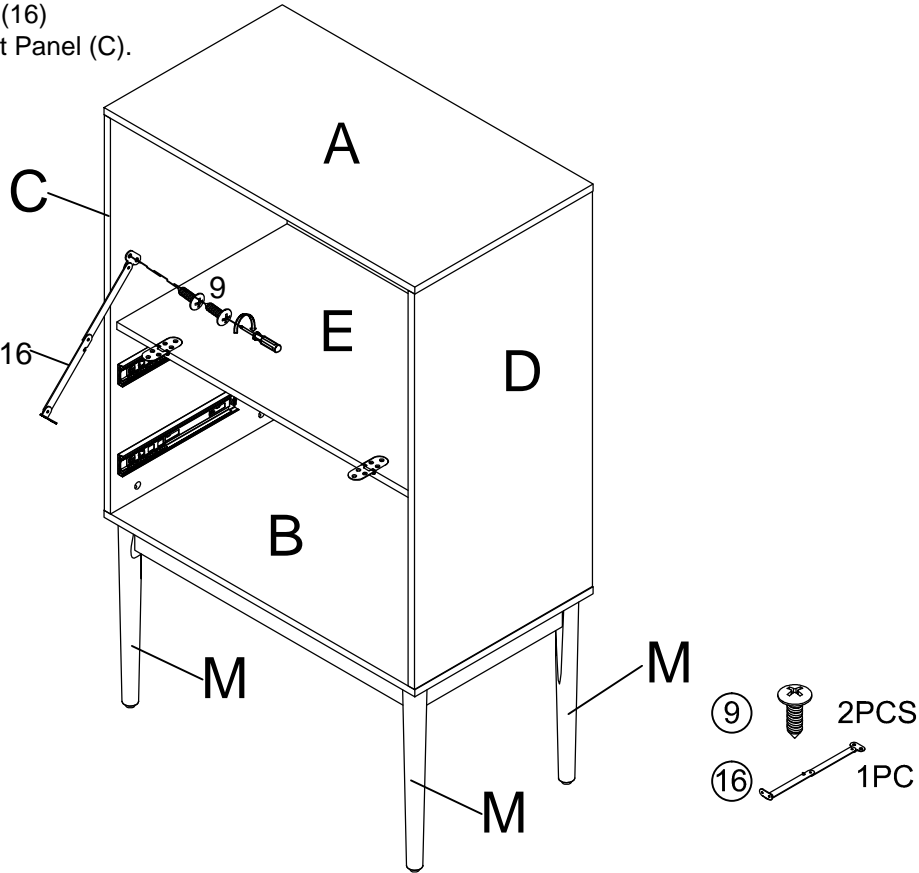

STEP 14

Position Right Flap Hinge (17) as shown and use Screw (9) to fasten (17) into designated holes on Right Panel (D).

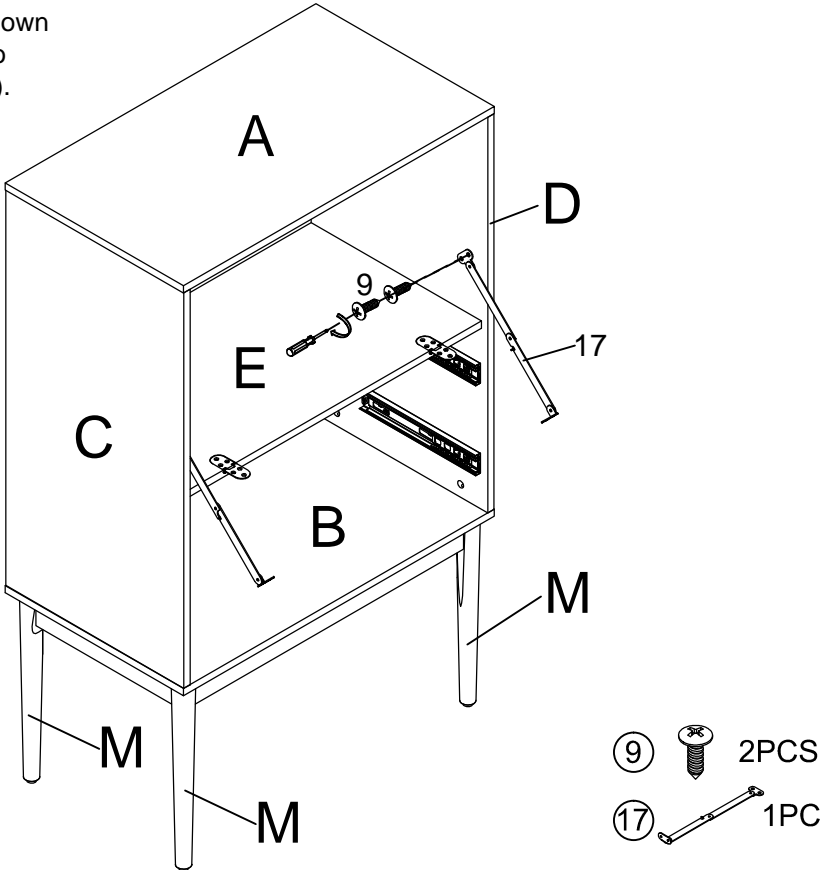

ASSEMBLY INSTRUCTIONS

TALL BAR CABINET

STEP 15

- With assistance, use Screw (12) to fasten Top Flap (F) to Hinge on Shelf Panel (E).
- Identify designated holes near left and right edge of (F) to fasten Left Flap Hinge (16) and Right Flap Hinge (17) and use Screw (9) to fasten (16 & 17) to (F).
- Use Screw (7) to fasten Handle (6).

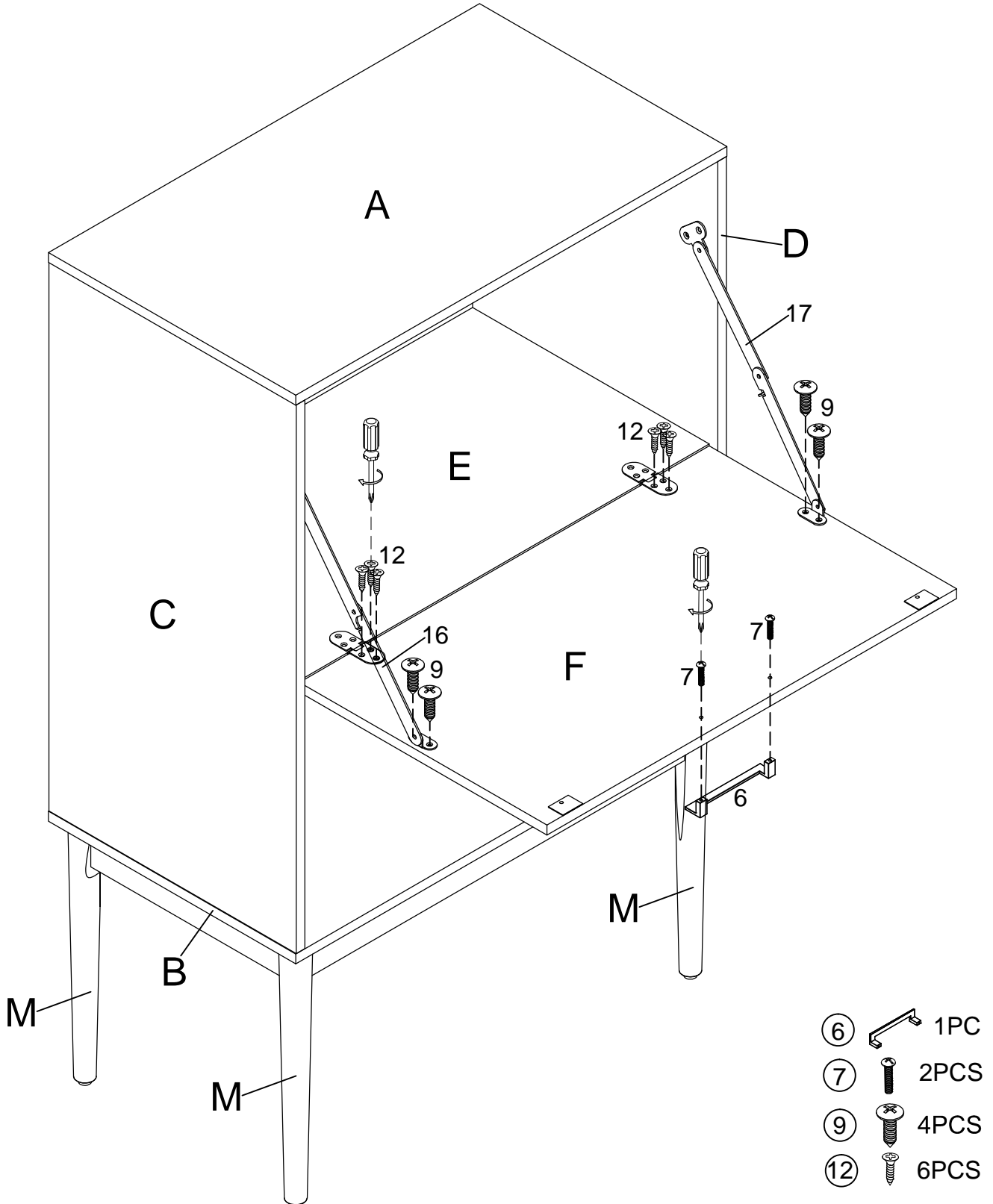

ASSEMBLY INSTRUCTIONS TALL BAR CABINET

STEP 16

To insert Drawers:

- On the Left and Right Panel (C & D), bring the ball-bearing slider on Slide Track forward to the front.
- On the Left and Right Panel of the drawer, align the back open-end of the Slide Runner to fit squarely into the groove on the open front-end of the Slide Track on (C & D). Be sure the drawer is not tilted or angled, and push in the drawer squarely.
- When the drawer is pushed in about half way, the Trigger Disconnect Lever on Slide Runner will be engaged onto Slide Track which will create a slight resistance - this is normal. Pull out the drawer a little bit and gently push in the drawer again to engage the Trigger Disconnect Lever to the slide mechanism on Slide Track. The drawer should now slide smoothly.
- If the drawer cannot be pushed in or stuck, do not force it in. Remove the drawer and repeat the steps above.

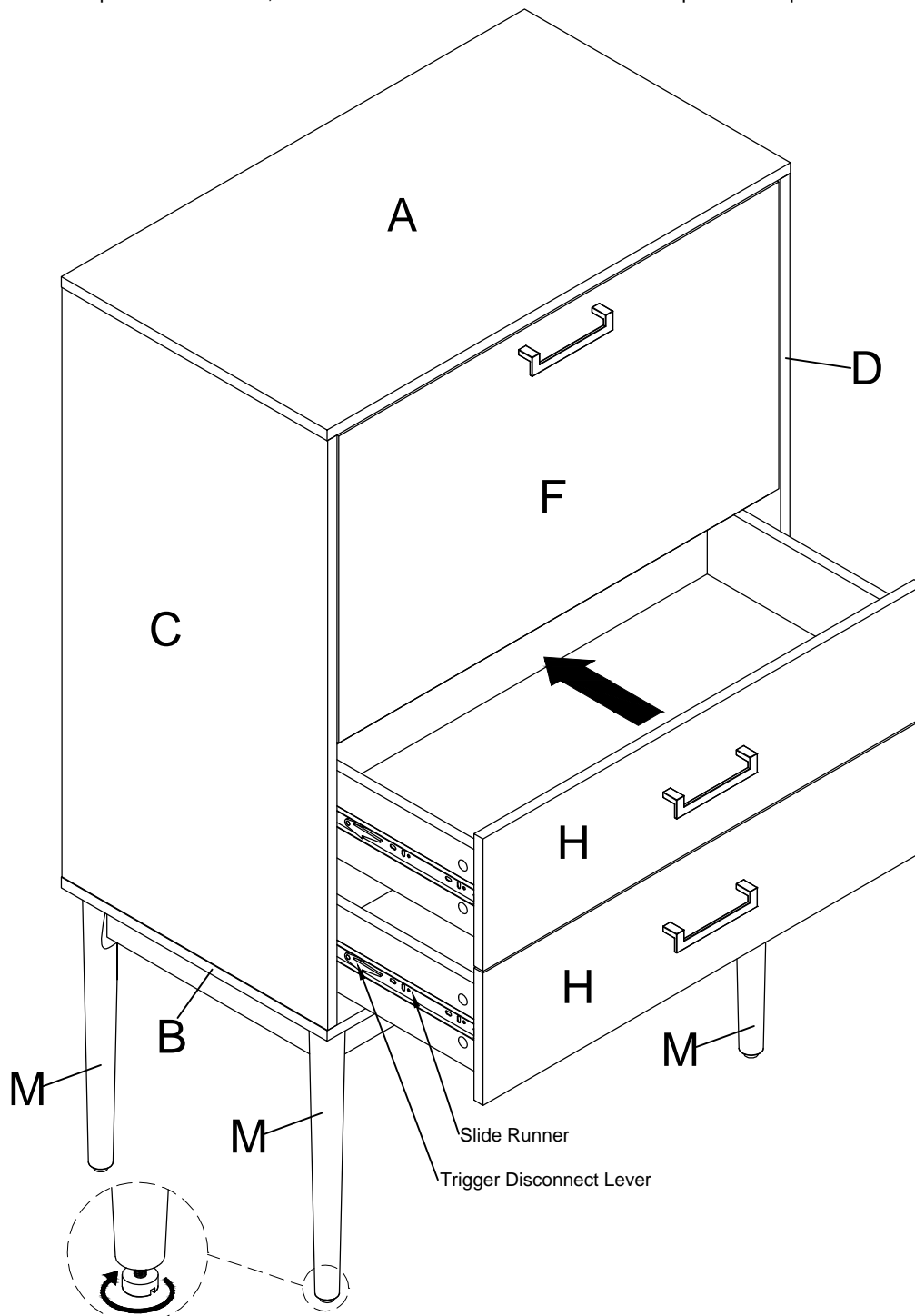

Note: It is important to adjust the levelers on the bottom of Leg (M) when the unit is fully assembled and placed upright. Always extend the adjustable leveler until it is firmly on the floor.

Important: Safety strap kit (part #18) must be installed to prevent tip-over which may cause damage and /or injury.

ASSEMBLY INSTRUCTIONS TALL BAR CABINET

STEP 17



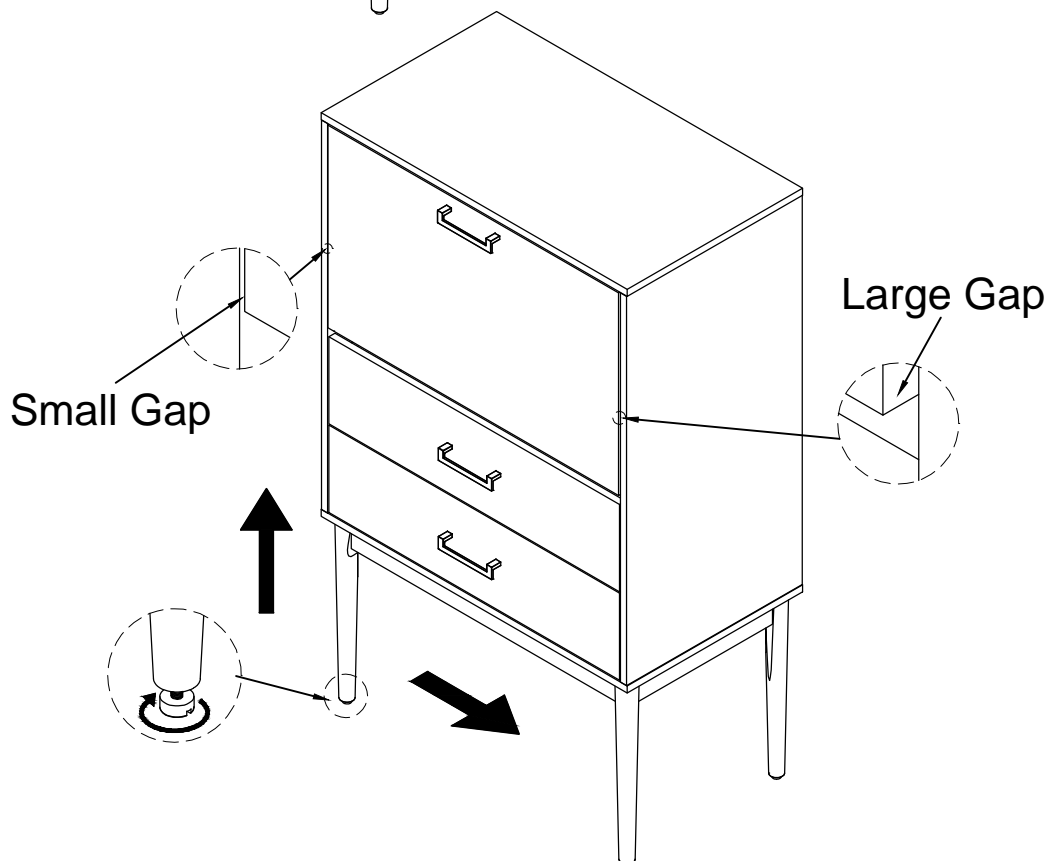
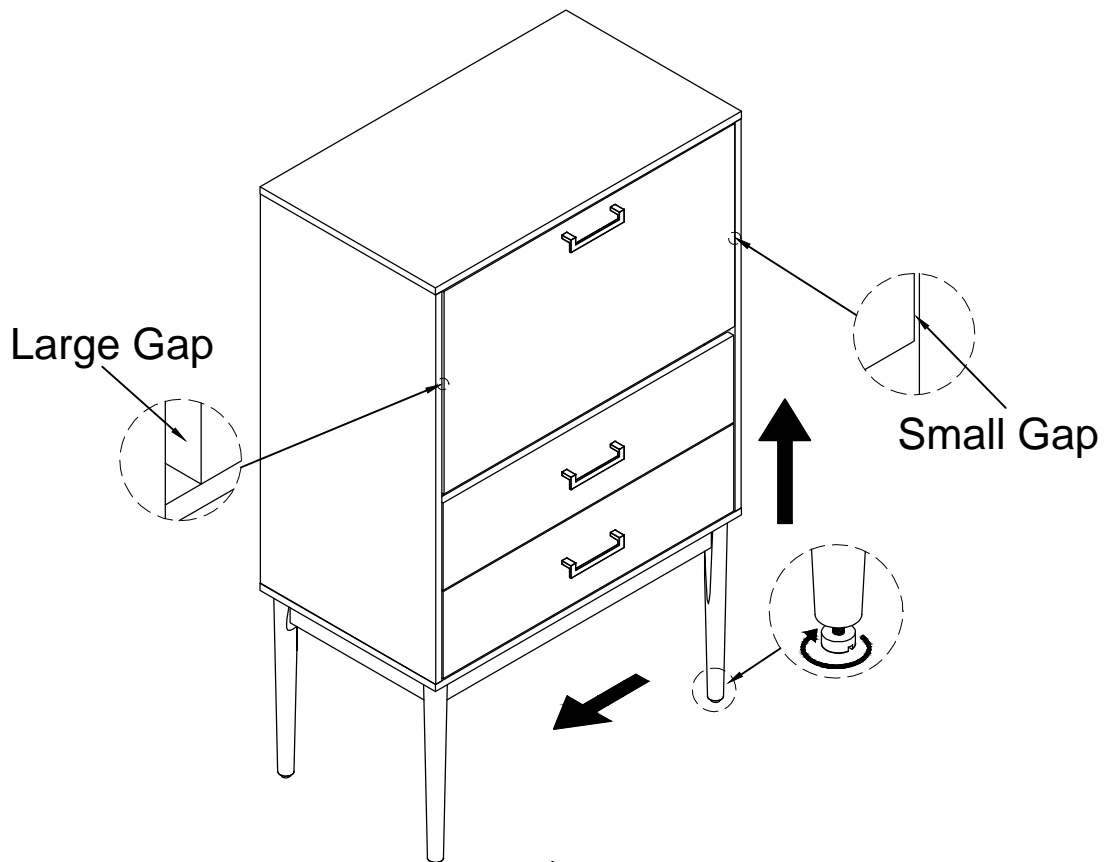

Extend adjustable leveler until it's firmly in contact with the floor.

If the gap of right side is small, higher the right adjustable leveler or lower left adjustable leveler, vice versa.

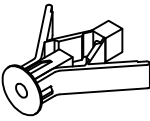

If relocating, adjust leveler as needed until it's firmly in contact with the floor in new location. then adjust the lever as above instruction.

ASSEMBLY INSTRUCTIONS TALL BAR CABINET

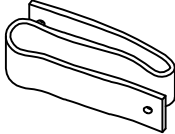
#18	A	B	C	D	E
			 D8*3/4"	 D8*1-1/2"	
Safety Strap Kit 1 SET	Wall Anchor 1 PC	Washer 2 PCS	Short Screw 1 PC	Long Screw 1 PC	Safety Wall Strap 1 PC

SAFETY WALL STRAP INSTALLATION

It is highly recommended to install the safety strap to prevent tip-over which can cause damage and /or injury.

1. Insert Short Screw (C) through Washer (B) and Safety Strap (E) to screw onto the Back edge of Top Panel (A). Use a Phillips screwdriver to drive (C).
2. Drill a 11/32" hole at the location where you want to secure the unit. The drilled hole has to level with safety strap on the back edge of (A). Next, fit Wall Anchor (A) into the drilled hole.
3. Insert Long Screw (D) through Washer (B) and Safety Strap (E) to screw into Wall Anchor (A). Use a Phillips screwdriver to drive (D).

Note: This item is not designed to store clothing.

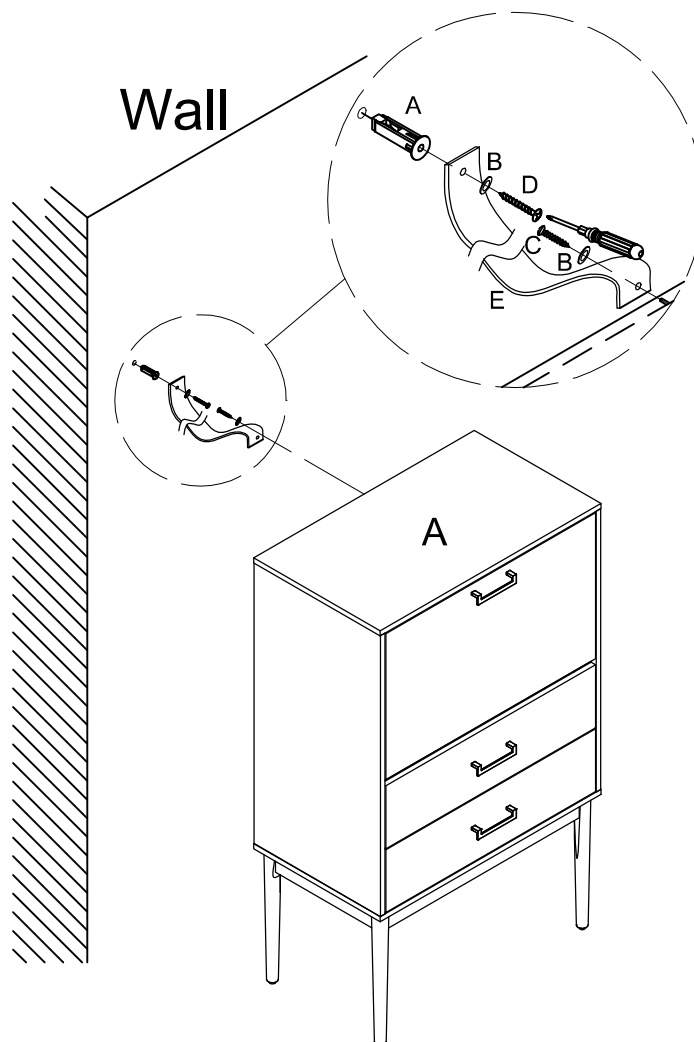

The assembly of the Bar Cabinet is complete.