

Assembly Instructions

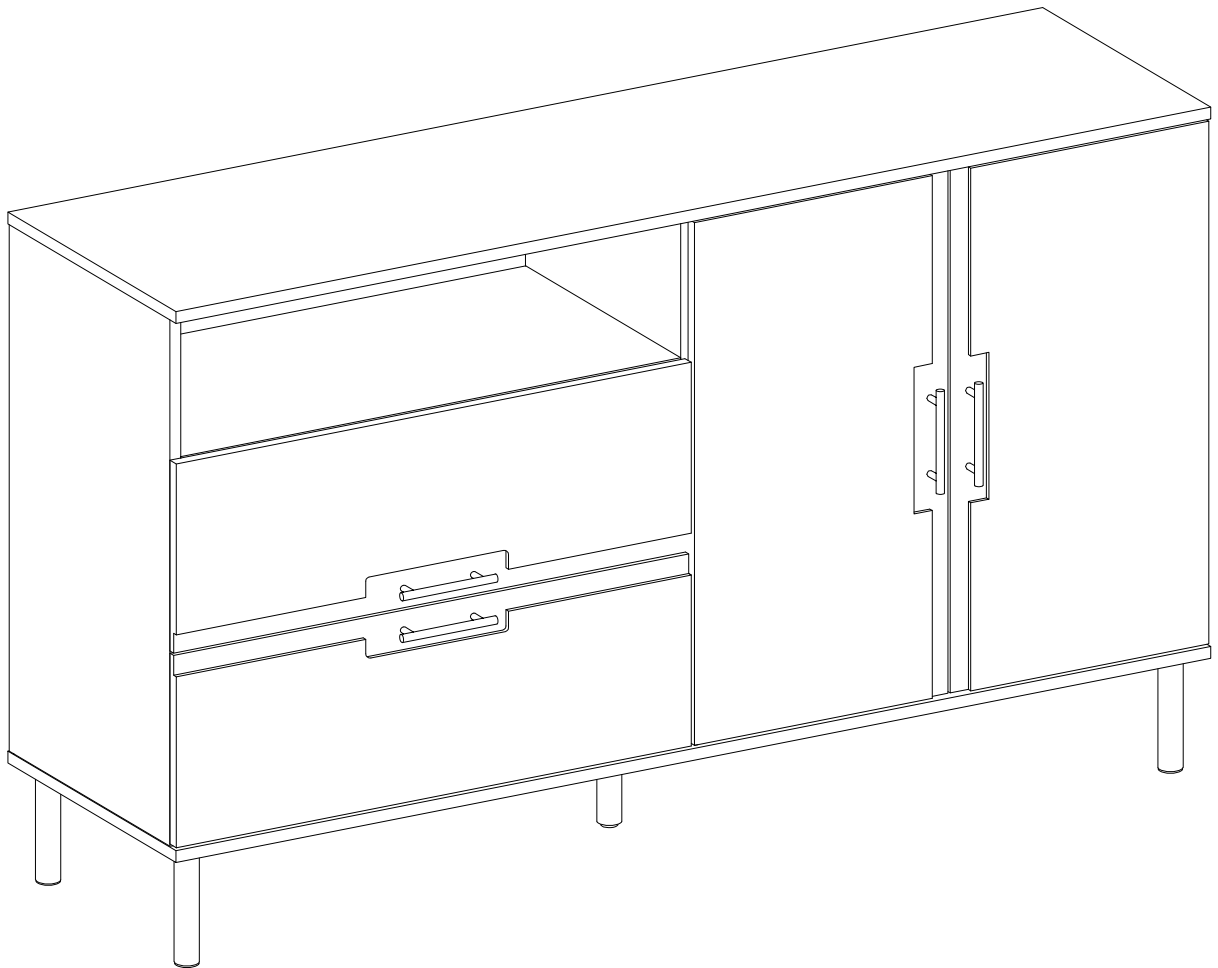

General Assembly Guidelines

- I. Ensure that all parts and hardware are available before beginning assembly.
- II. Follow each step carefully to ensure the proper assembly of this product.
- III. Two people are recommended for ease in the assembly of this product.
- IV. The three main types of hardware used to assemble this product are: wood dowels, screws and bolts.
- V. The provided glue is to secure wood dowels in place. When first inserting dowels, locate the appropriate hole for the dowel, place a small amount of glue in the hole and insert the dowel. Wipe away excess glue immediately.

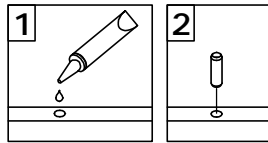

In future assembly steps when dowels are necessary to attach assembly parts together, place a small amount of glue on the end of the dowel before attaching parts together. Wipe away excess glue immediately.

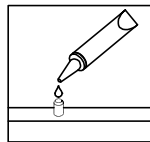

- VI. A Phillips head screwdriver is required for the assembly of this product.

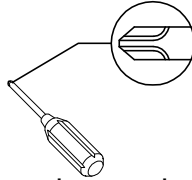

- VII. Power tools should not be used to assemble this product.

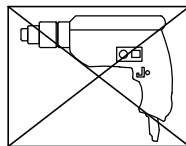

- VIII. Drill may be needed for securing product to wall.

- IX. Concealed hinges are three-way adjustable.

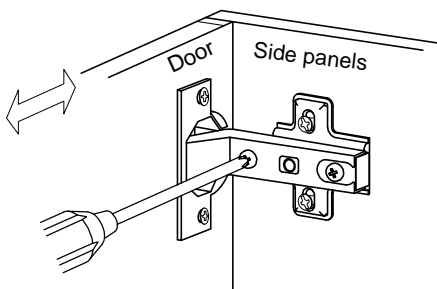

Horizontal
by screw adjustment

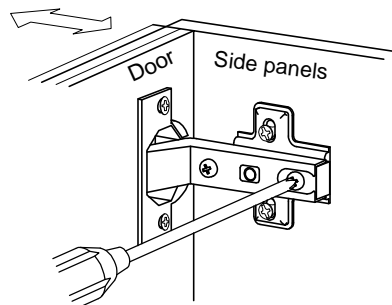

In-and-Out
by loosening the hinge-arm
mounting screw or via cam
adjustment

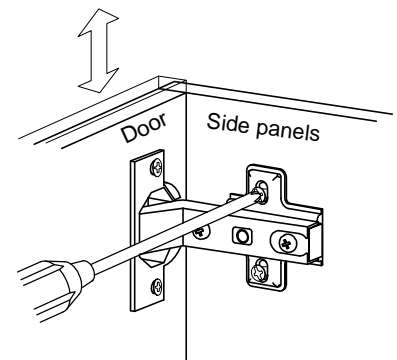





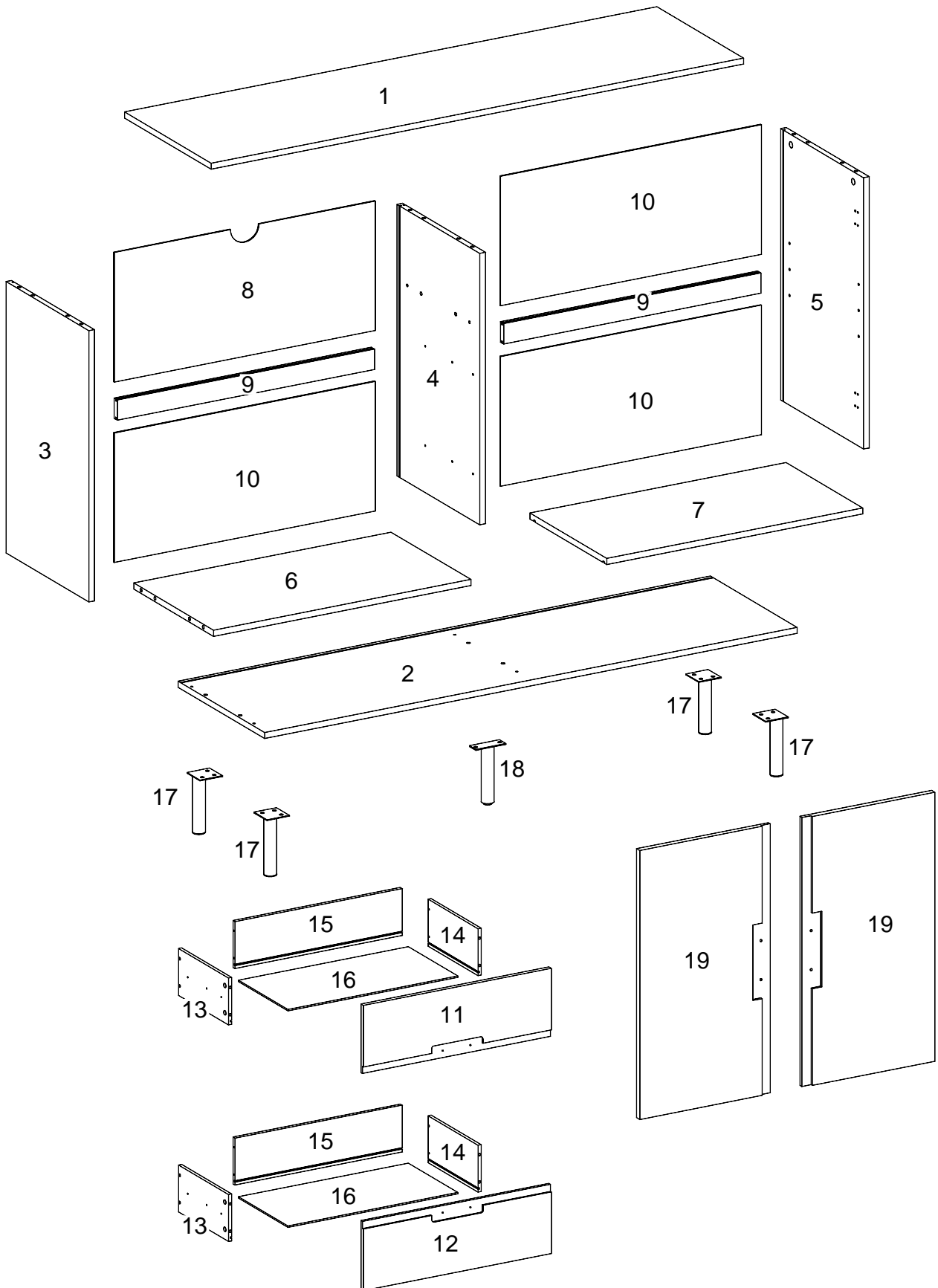



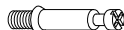







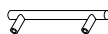

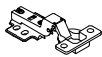

Vertical
Via slots in the mounting
plate or via cam adjustment

Parts List

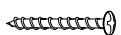
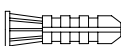
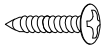

Hardware List

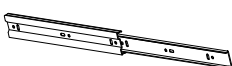
A		Ø8x30mm	Wooden dowel	16 pcs
B		Ø6x35mm	Cam bolt	18 pcs
C		Ø15x11mm	Cam lock	10 pcs
D		Ø30mm	Sticker	18 pcs
E		Ø15x9.5mm	Cam lock	8 pcs
F		Ø6x50mm	Screw	6 pcs
G			Plastic wedge	16 pcs
H		Ø3x17mm	Screw	16 pcs
J		Ø4x38mm	Screw	8 pcs
K			Handle	4 pcs
L		Ø4x16mm	Bolt	8 pcs
M			Europe Hinge	2 pcs
N			Europe Hinge	2 pcs
P		Ø3.5x14mm	Screw	24 pcs
Q			Door stopper	1 pc
R		Ø3.5x14mm	Screw(Black)	2 pcs
S			Shelf support pin	4 pcs
T		4mm	Hex Key	1 pc
U		Ø6x12mm	Bolt	14 pcs
V			Velcro strap	2 pcs
W		Ø4x25mm	Screw	2 pcs
X			Nut	2 pcs
Y		Ø4x12mm	Screw	2 pcs
Z		Ø3.5x12mm	Screw	24 pcs
AA			Glue tube	1 pc
BB			Drawer slider	2 Set

* Note: This piece comes preassembled for shipping purposes and must be disassembled to complete the desk assembly.

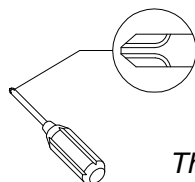

Philips head screwdriver required for assembly
(not included)

The hardware quantities listed above are required for proper assembly.
Some extra hardware may also have been included.

Step 1

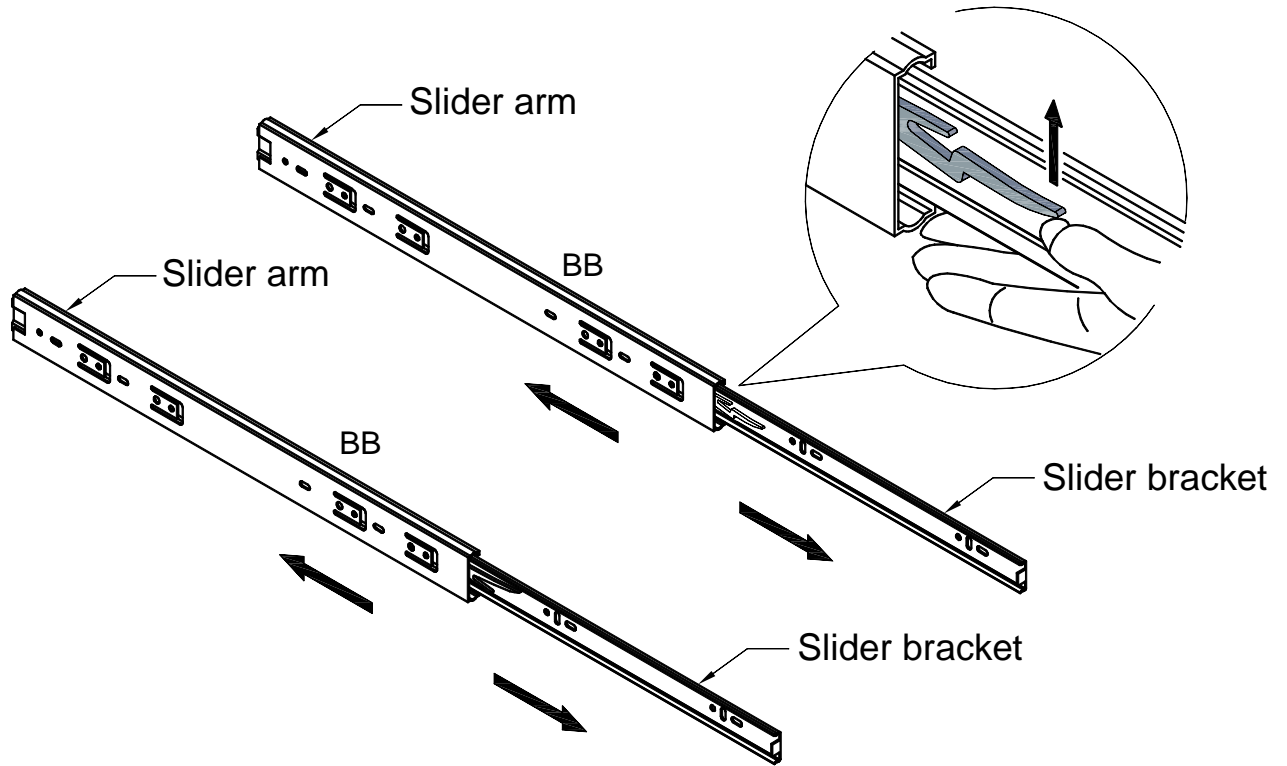

Separate the slide bracket from the slide arm as per diagram.

Step 2

X 2

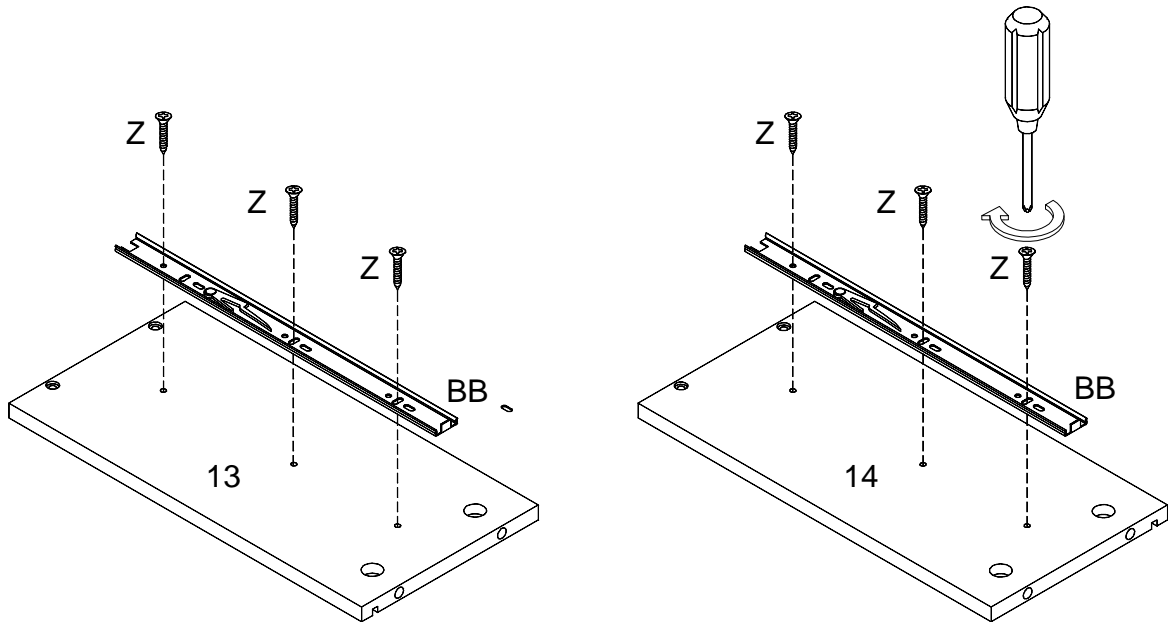

Using screw (Z) attach drawer slider bracket (BB) to parts (13,14) with Philips head screwdriver as per diagram .

Step 3

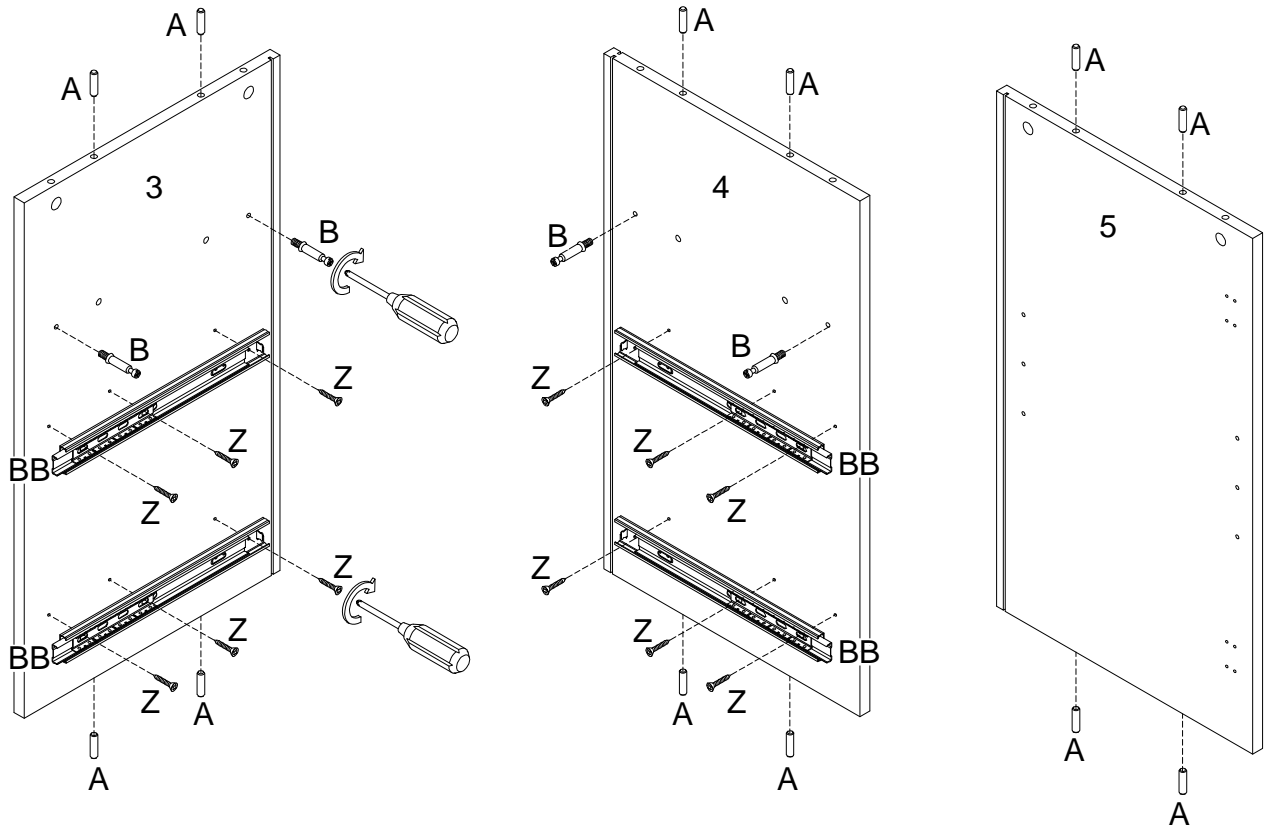

Insert wooden dowel (A) into parts (3,4,5) and secure cam bolt (B) to parts (3,4), then using screw (Z) attach Drawer slider arm (BB) to parts (3,4) with Philips head screwdriver as per diagram.

Step 4

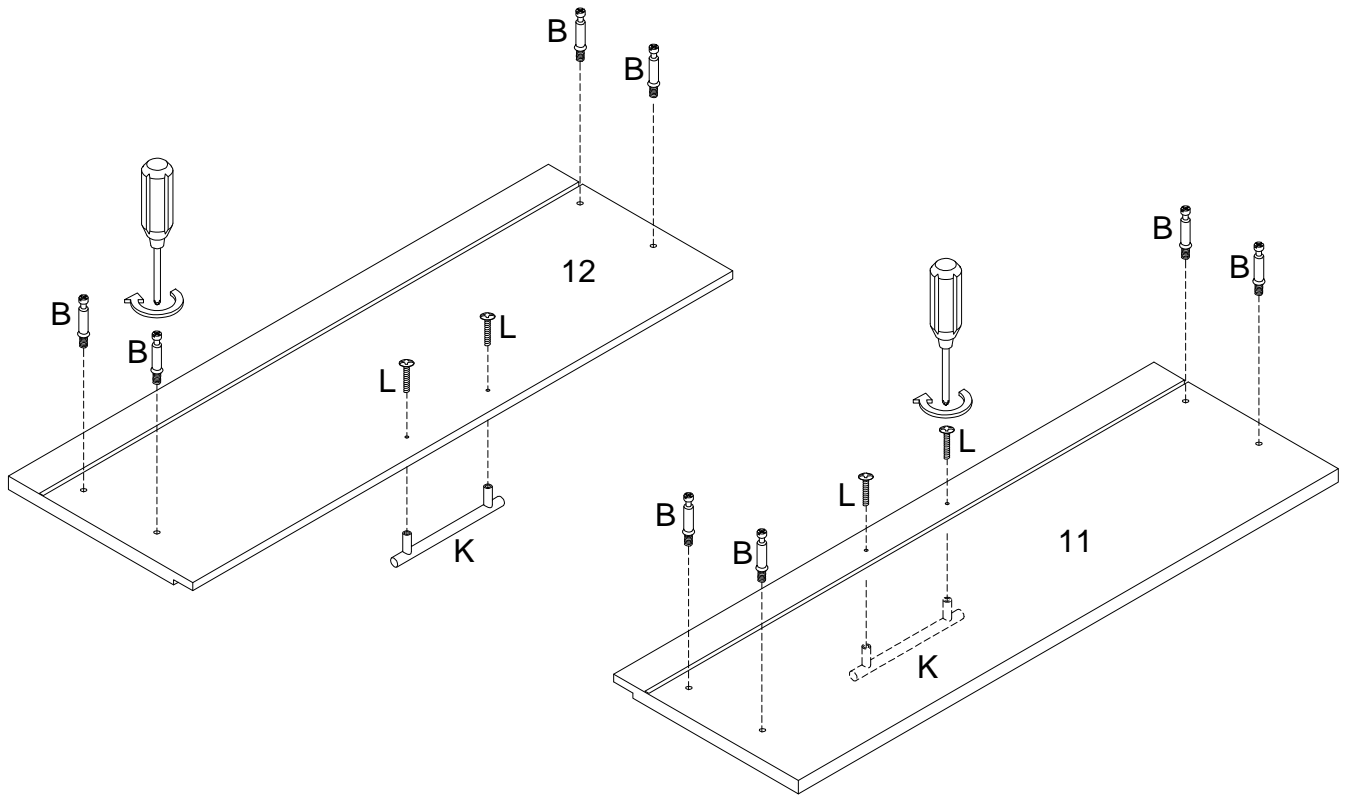

Secure cam bolt (B) to parts (11,12), then using bolt (L) attach handle (K) into parts (11,12) with Philips head screwdriver as per diagram.

Step 5

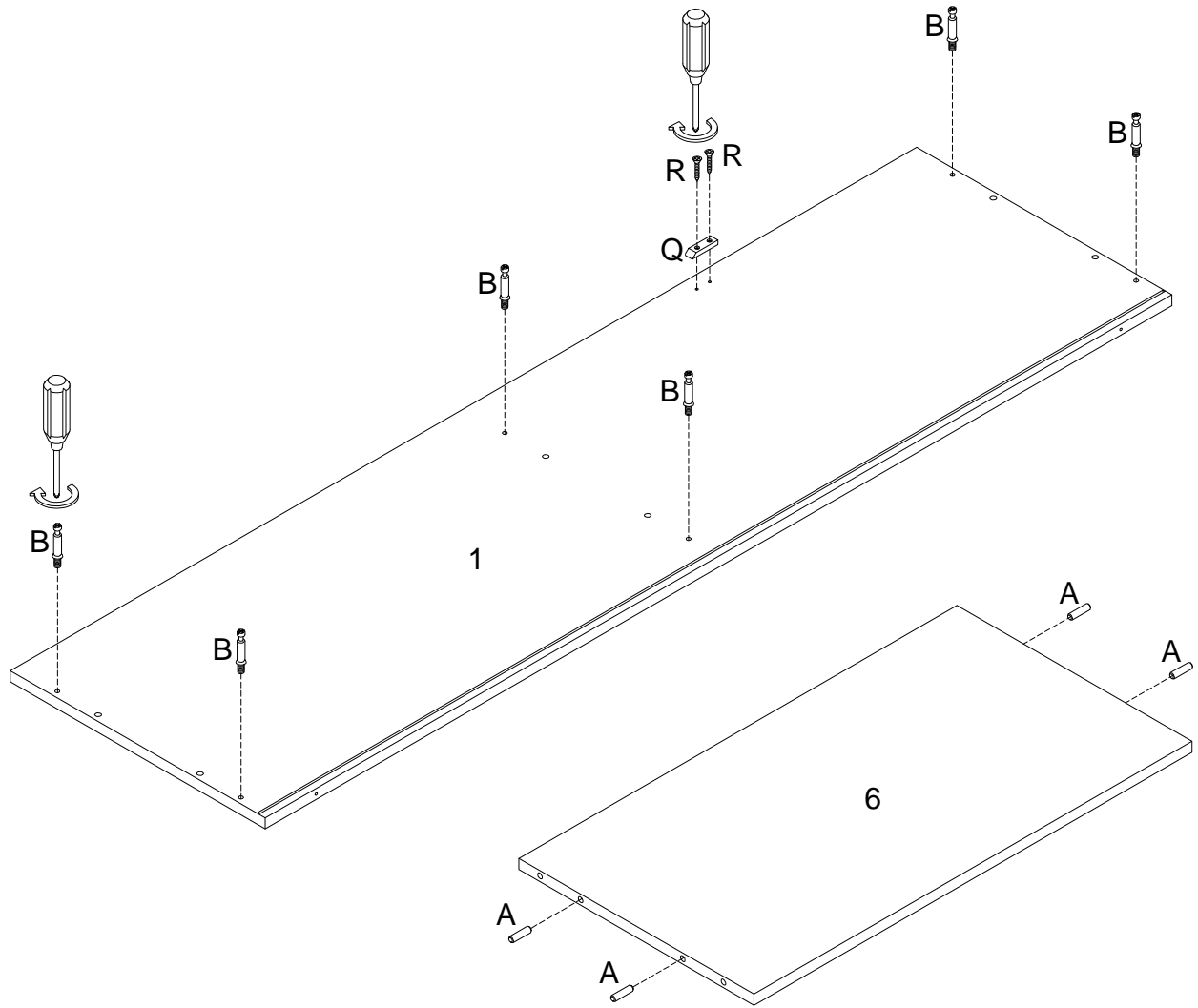

Insert wooden dowel (A) into part (6) and secure cam bolt (B) to part (1), then using screw (black) (R) attach Door stopper (Q) to part (1) with Philips head screwdriver as per diagram.

Step 6

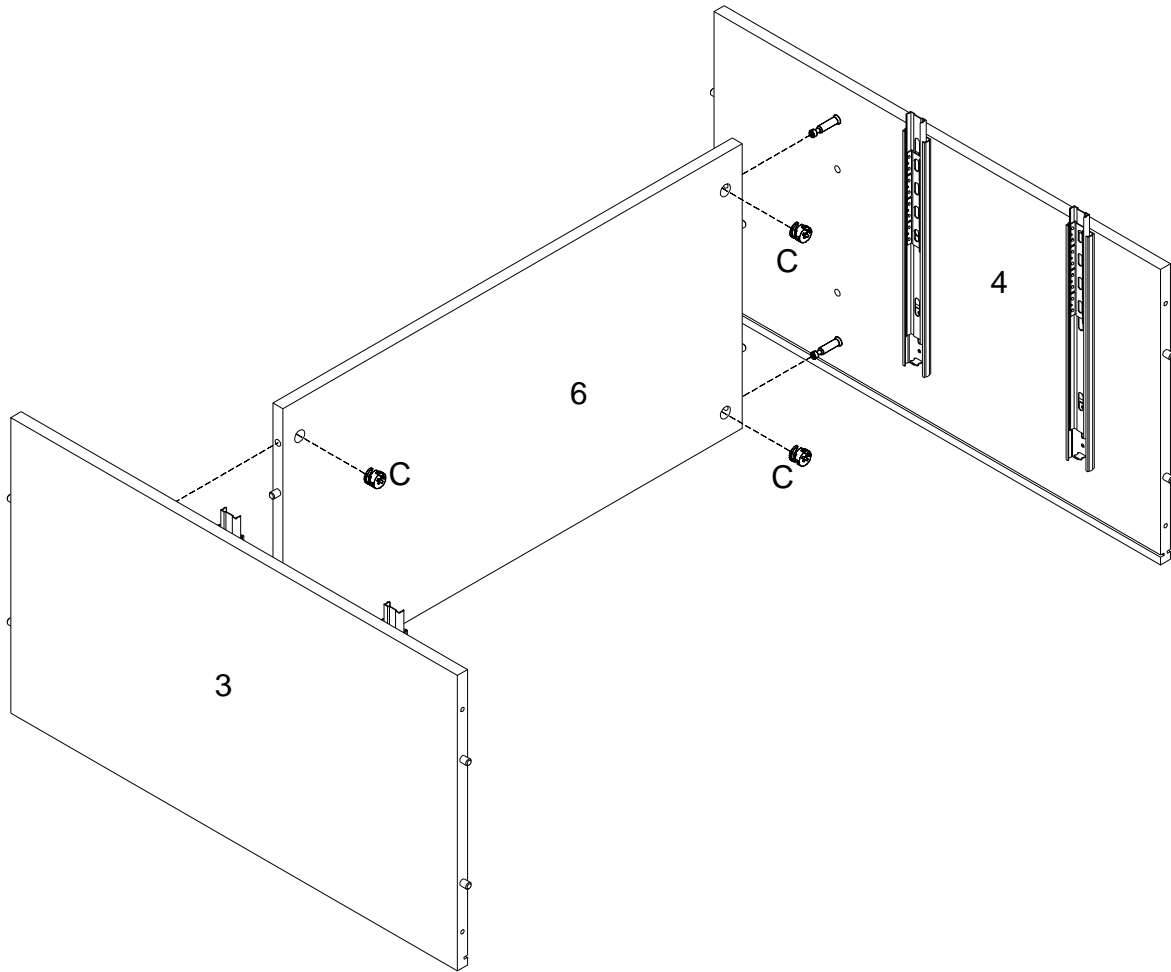
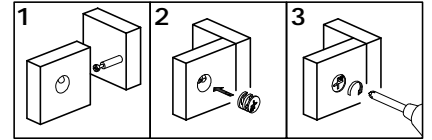

Using cam lock(C) attach part (6) to parts (3,4) with Philips head screwdriver as per diagram.

Step 7

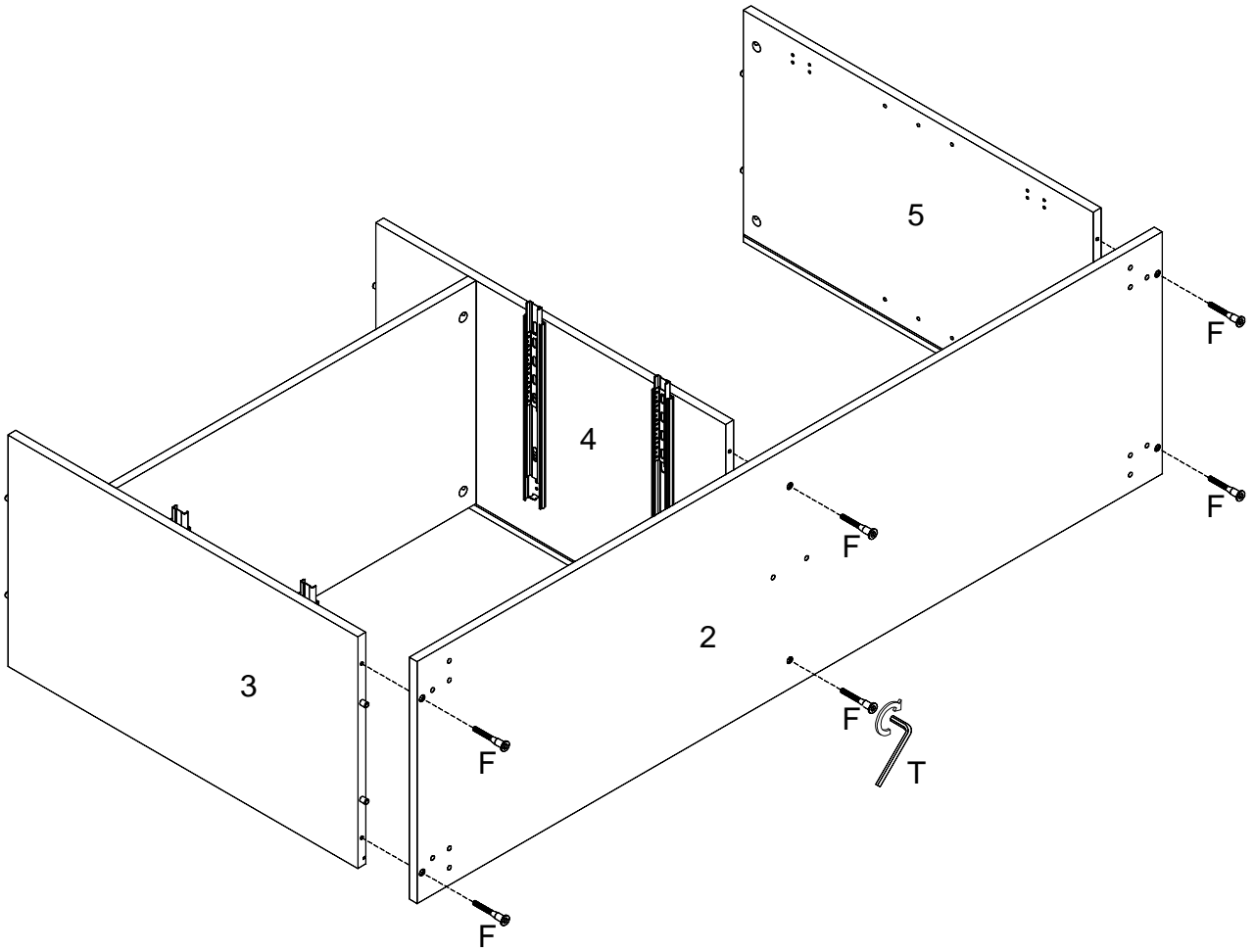

Using screw (F) attach part (2) into parts (3,4,5) with hex key (T) as per diagram.

Step 8

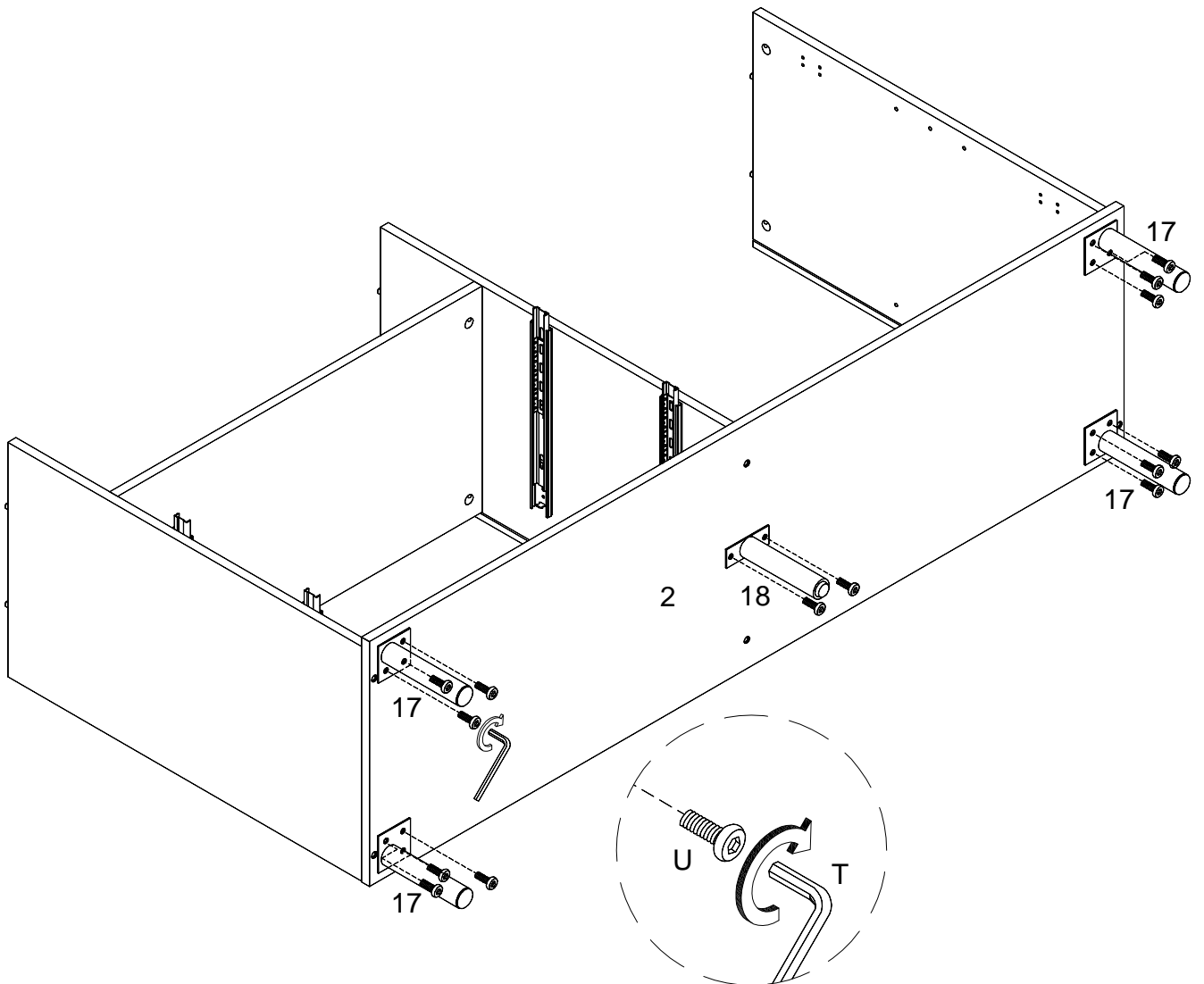

Using bolt (U) attach parts (17,18) to part (2) with hex key (T) as per diagram.

Step 9

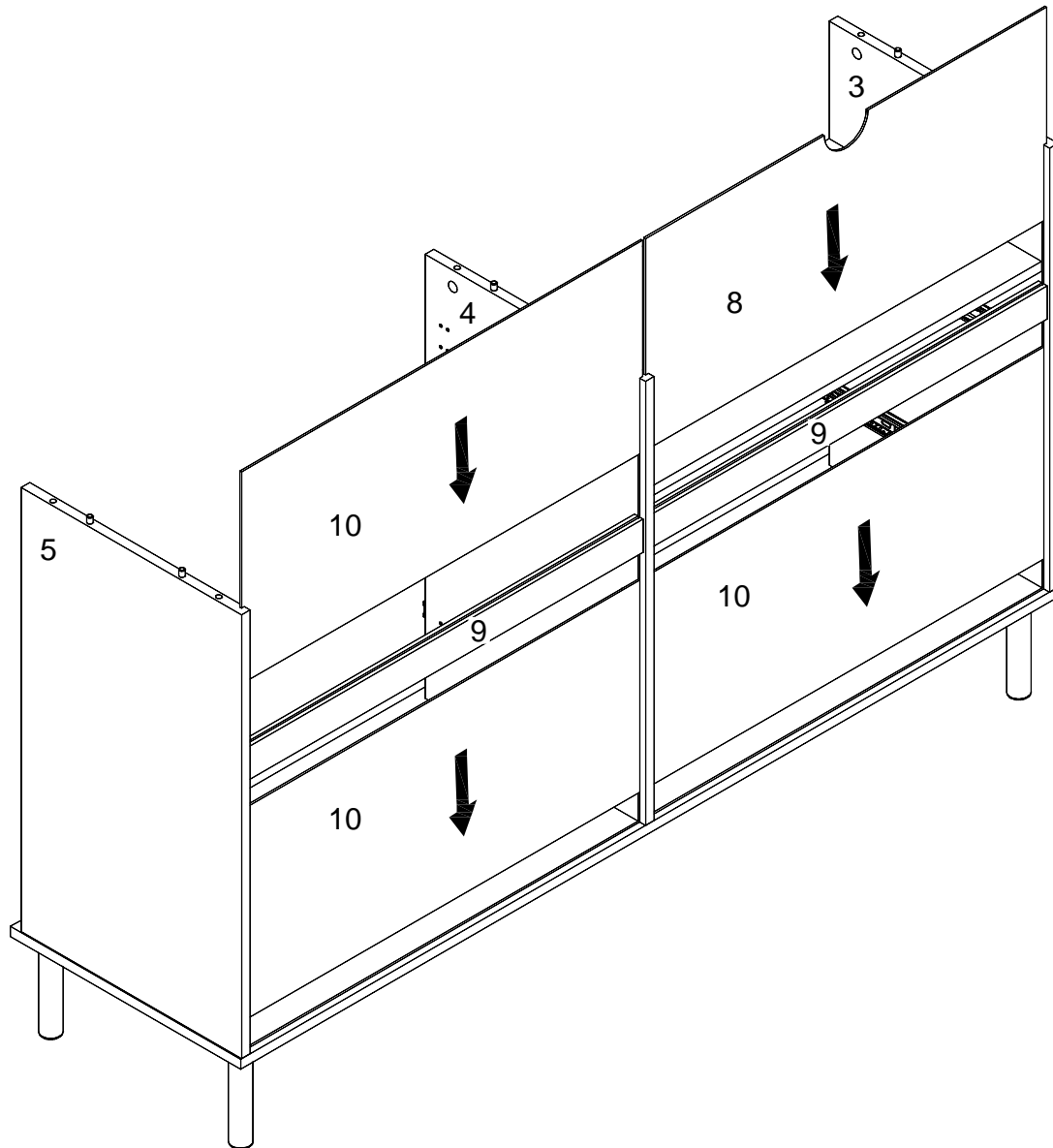

Put parts (8,9,10) as per diagram.

Step 10

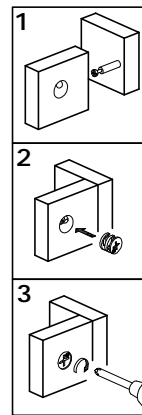
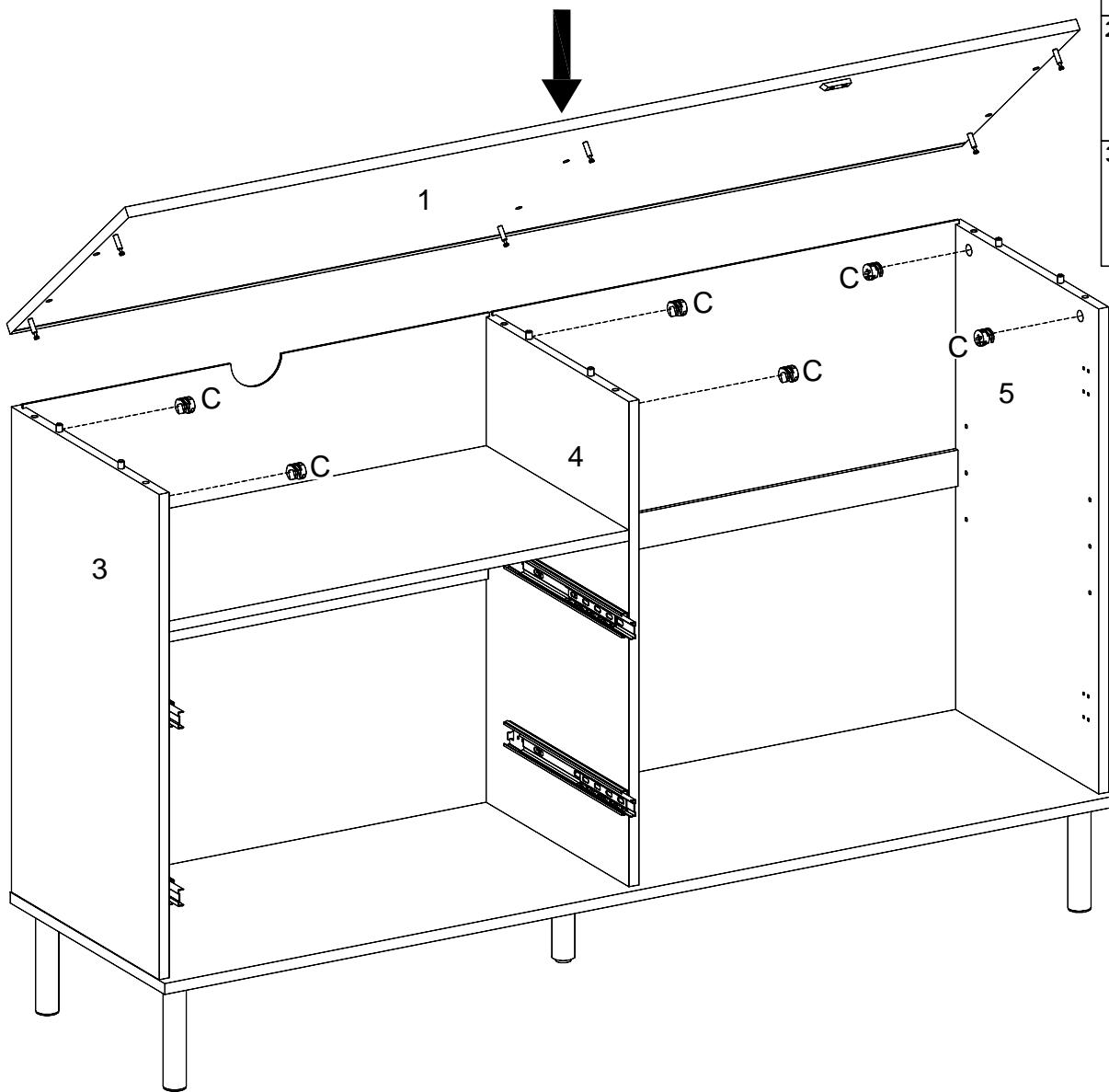

Using cam lock(C) secure part (1) to parts (3,4,5) with Philips head screwdriver as per diagram.

Step 11

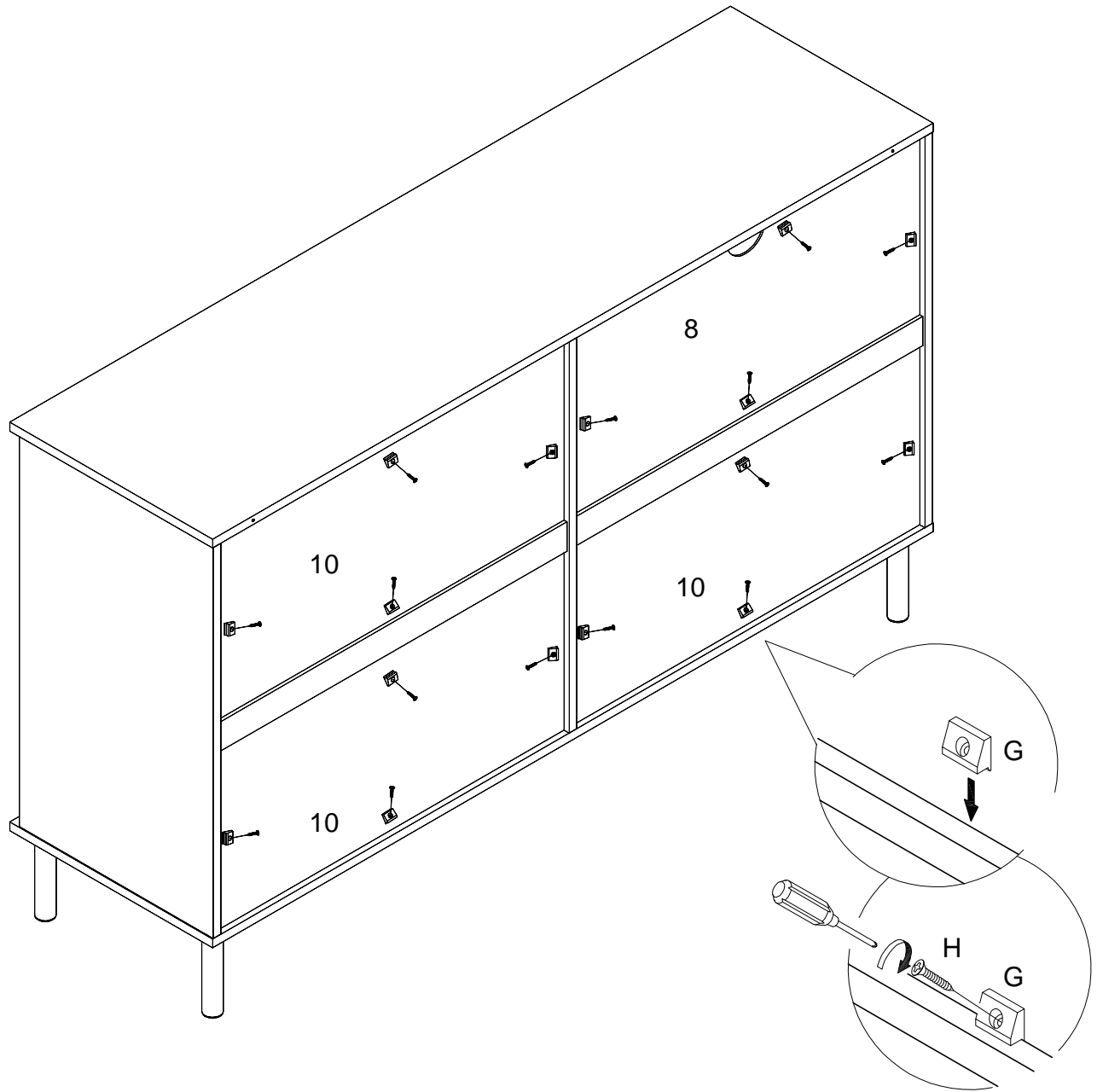

Using screw (H) to fix plastic wedge (G) with Philips head screwdriver as per diagram.

Step 12

X 2

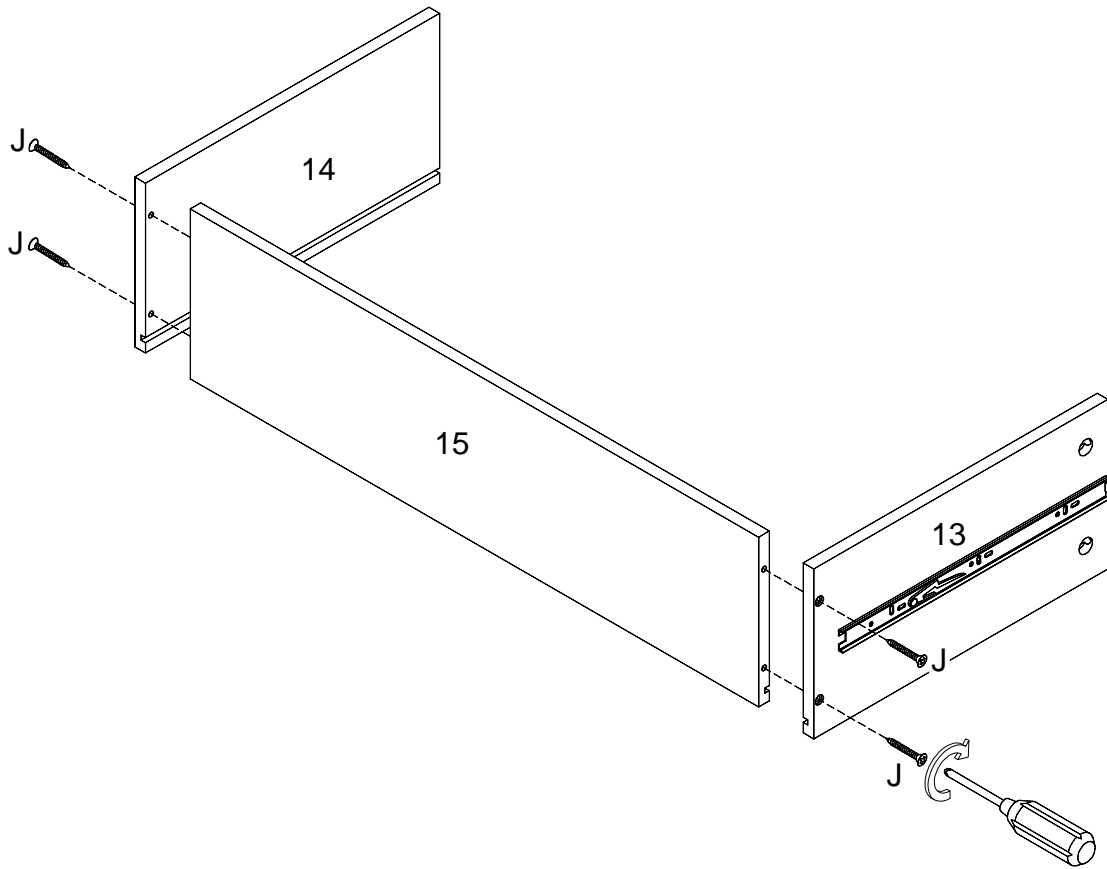

Using screw (J) attach parts (13,14) to part (15) with Philips head screwdriver as per diagram.

Step 13

X 2

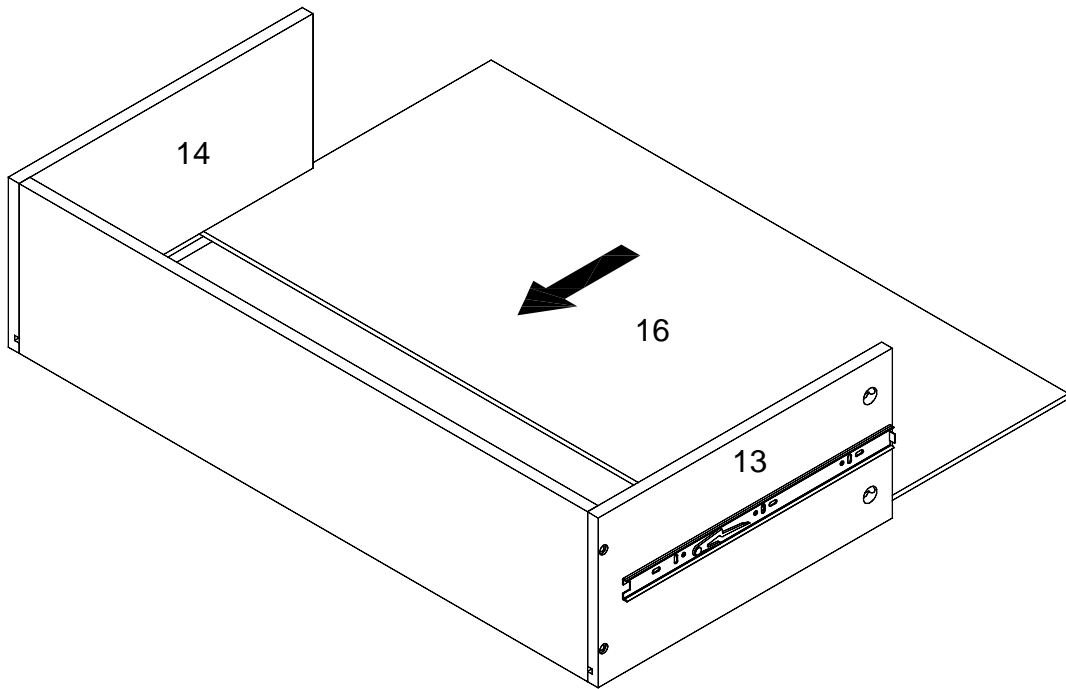

Put part (16) into parts (13,14) as per diagram.

Step 14

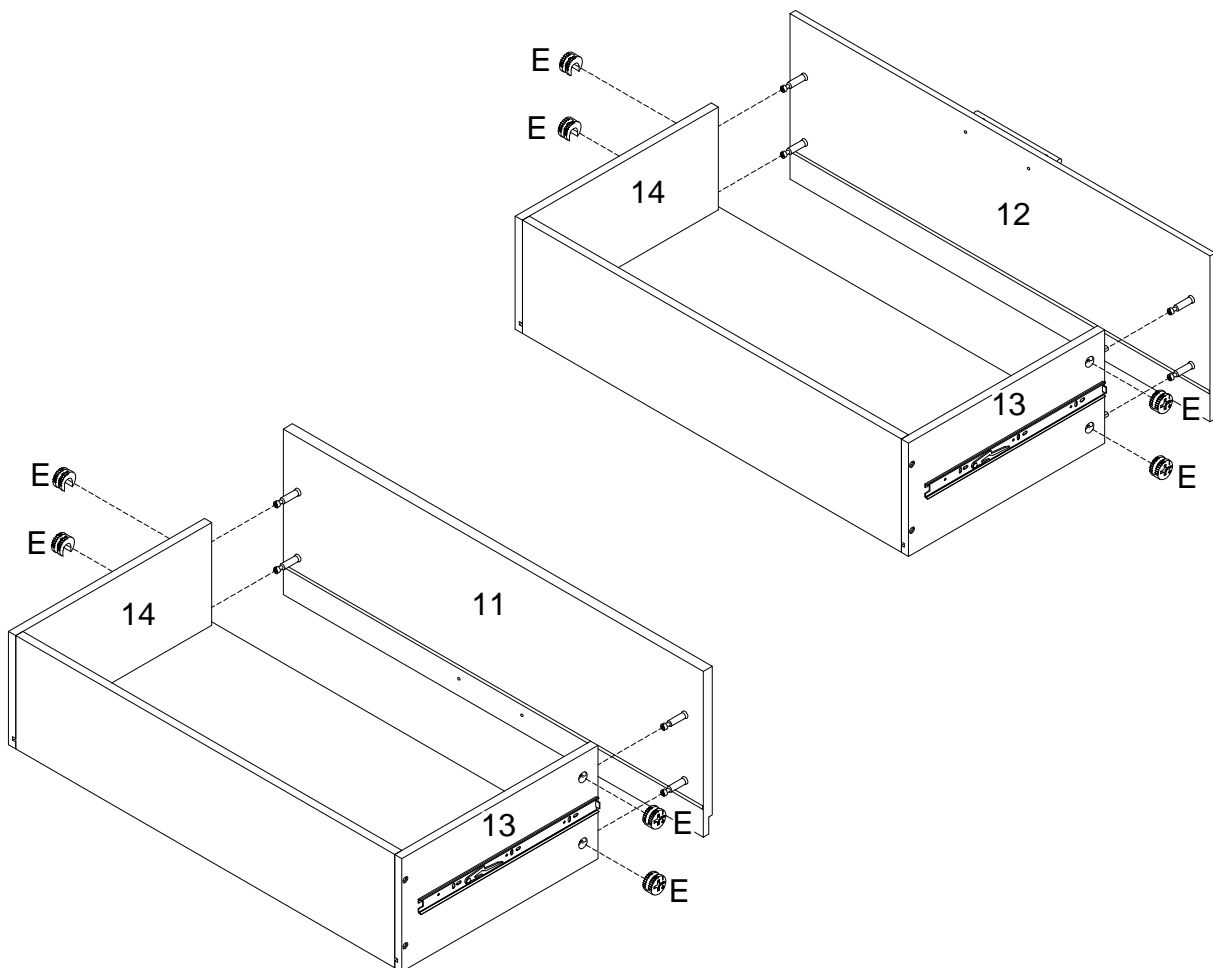
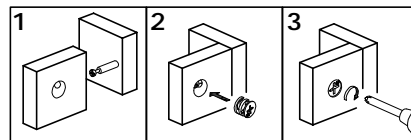

Using cam lock(E) secure parts (11,12) to parts (13,14) with Philips head screwdriver as per diagram.

Step 15

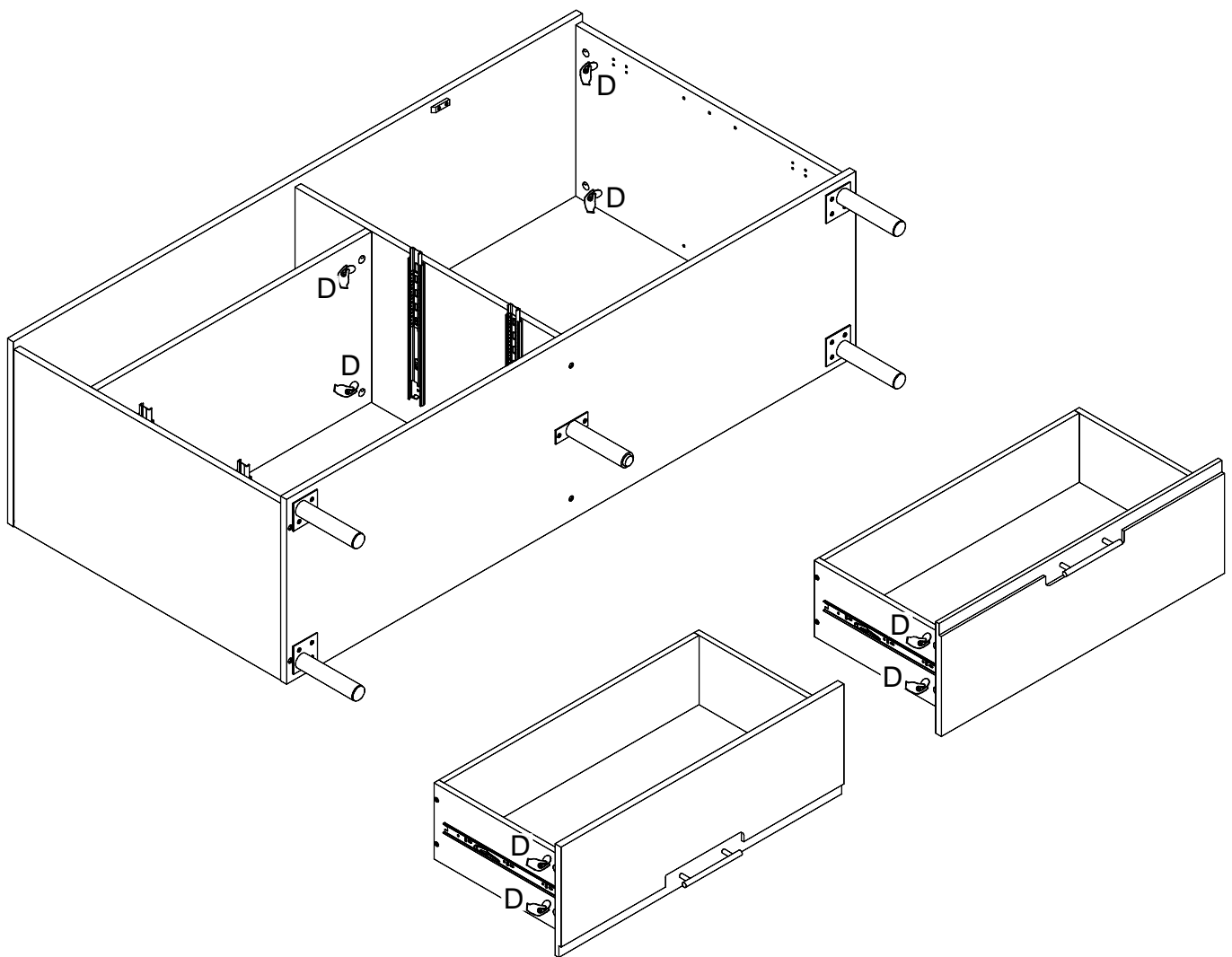

Place sticker (D) cover the holes as per diagram .

Step 16

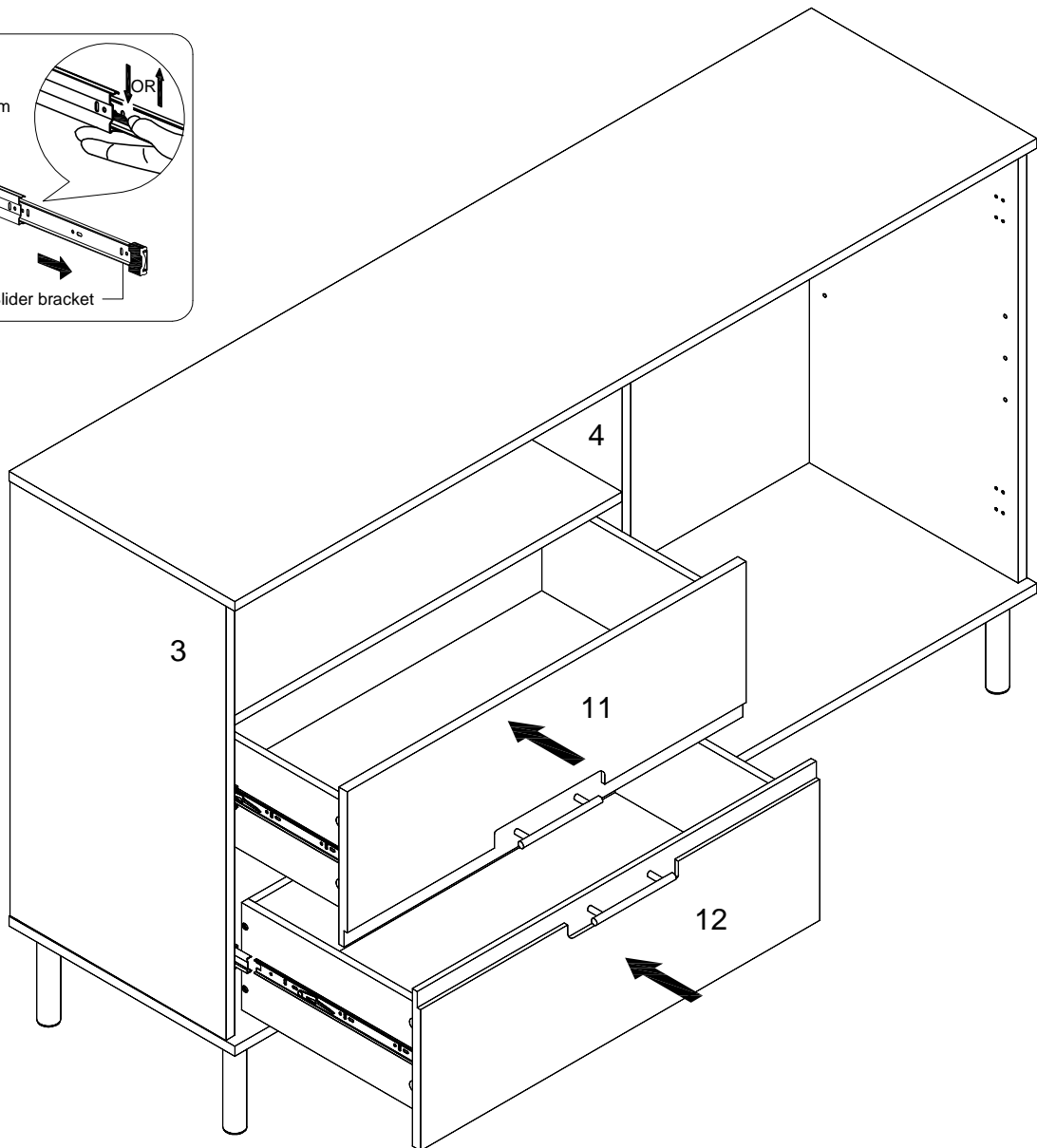
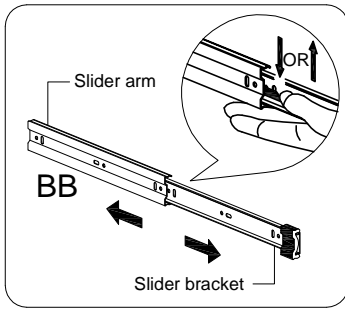

Assembled the drawers as per diagram

Note :If the drawer does not go in smoothly .Press or lift the plastic release lever .Pull out the slider bracket from the slider arm then re-assembled the drawer until they were going in smoothly well .

Step 17

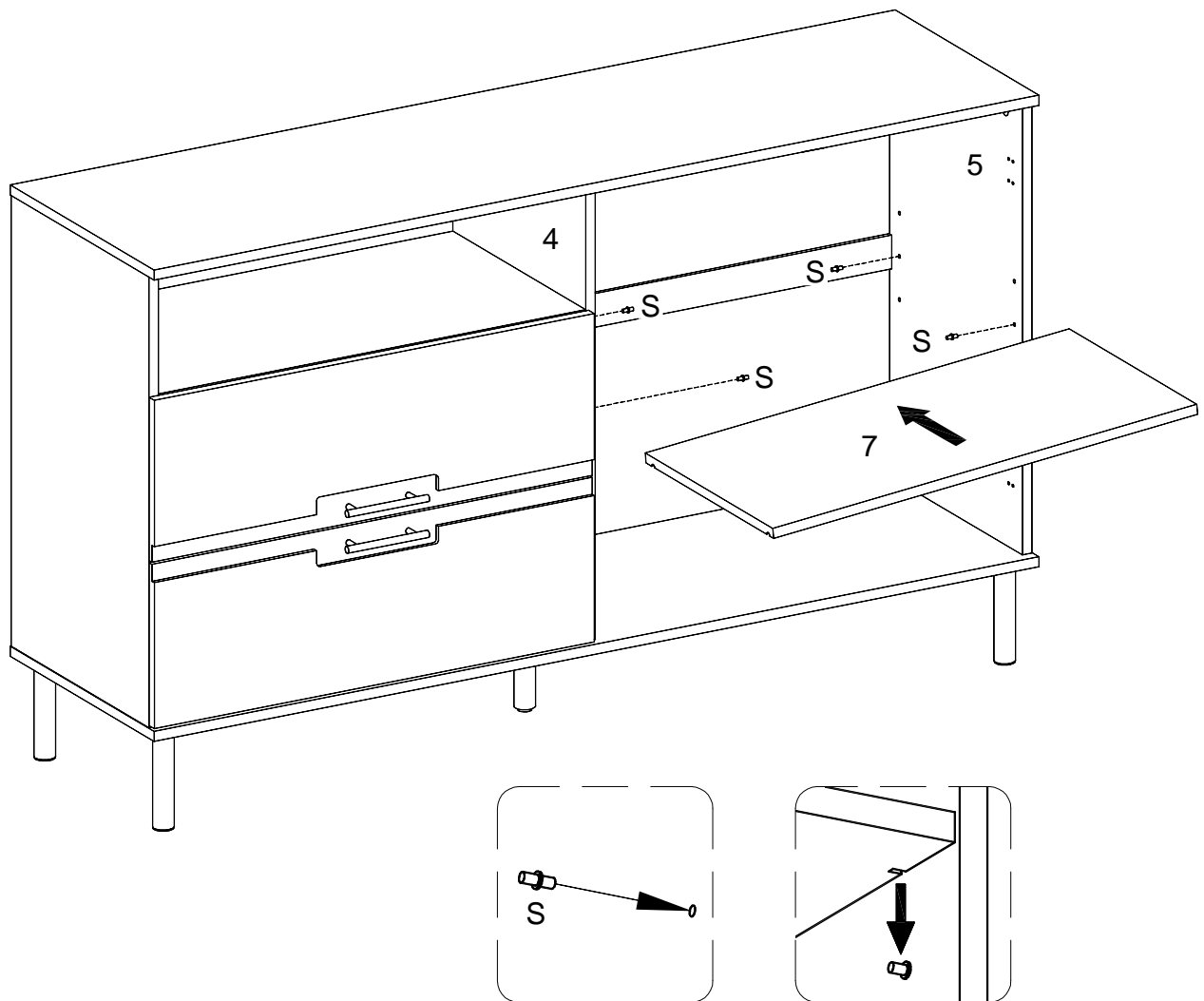

Insert shelf support pin (S) into parts (4,5) as per diagram. Make sure you place the four shelf support pins (S) in the same level. So the shelf is not tilted. Put part (7) into unit as per diagram. Tilt and rest the adjustable shelf(7) onto the shelf support pins .

Step 18

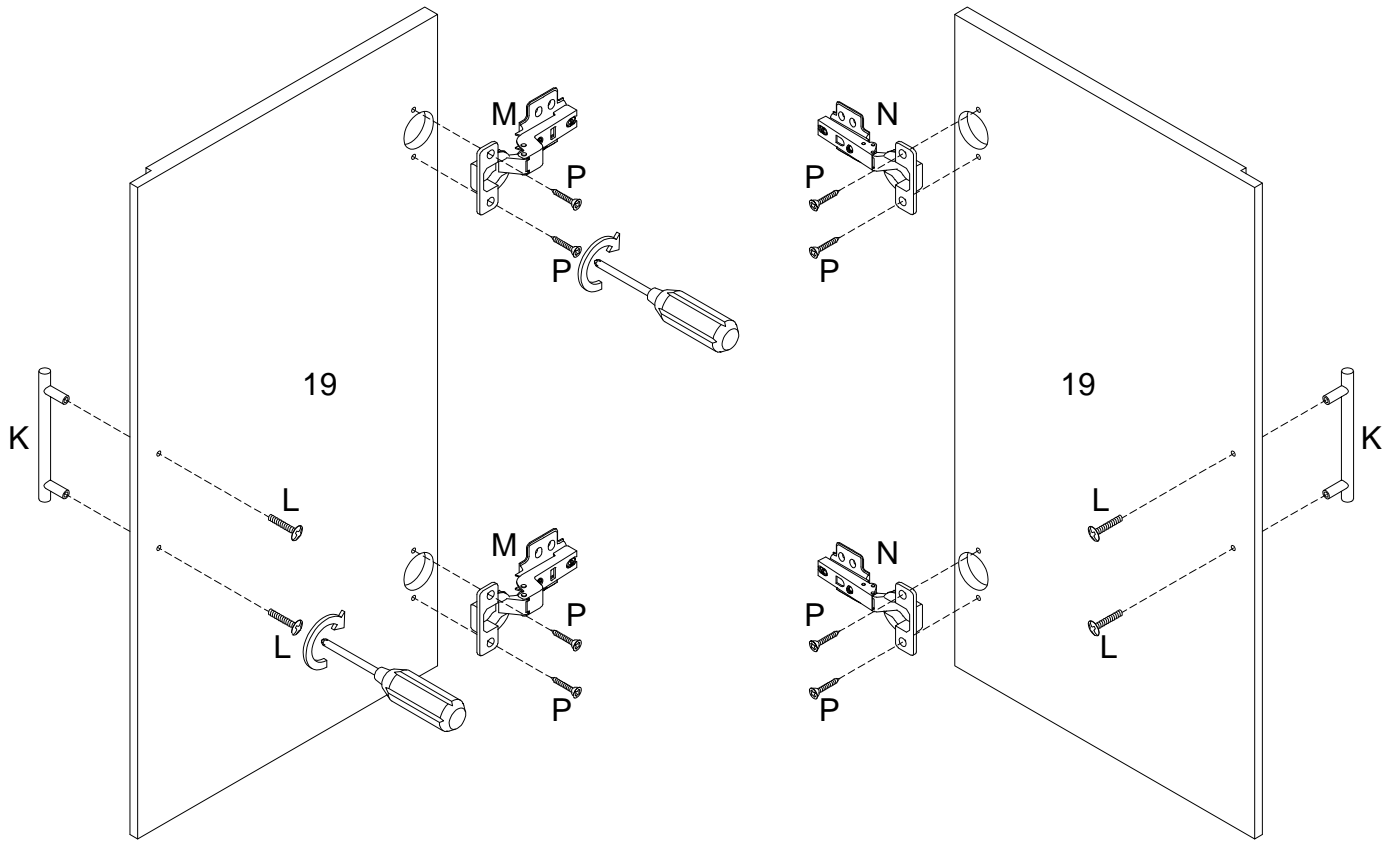

Using screw (P) attach Europe hinges (N,M) into part (19) , then using bolt (L) secure handle (K) to part (19) with Philips head screwdriver as per diagram.

Step 19

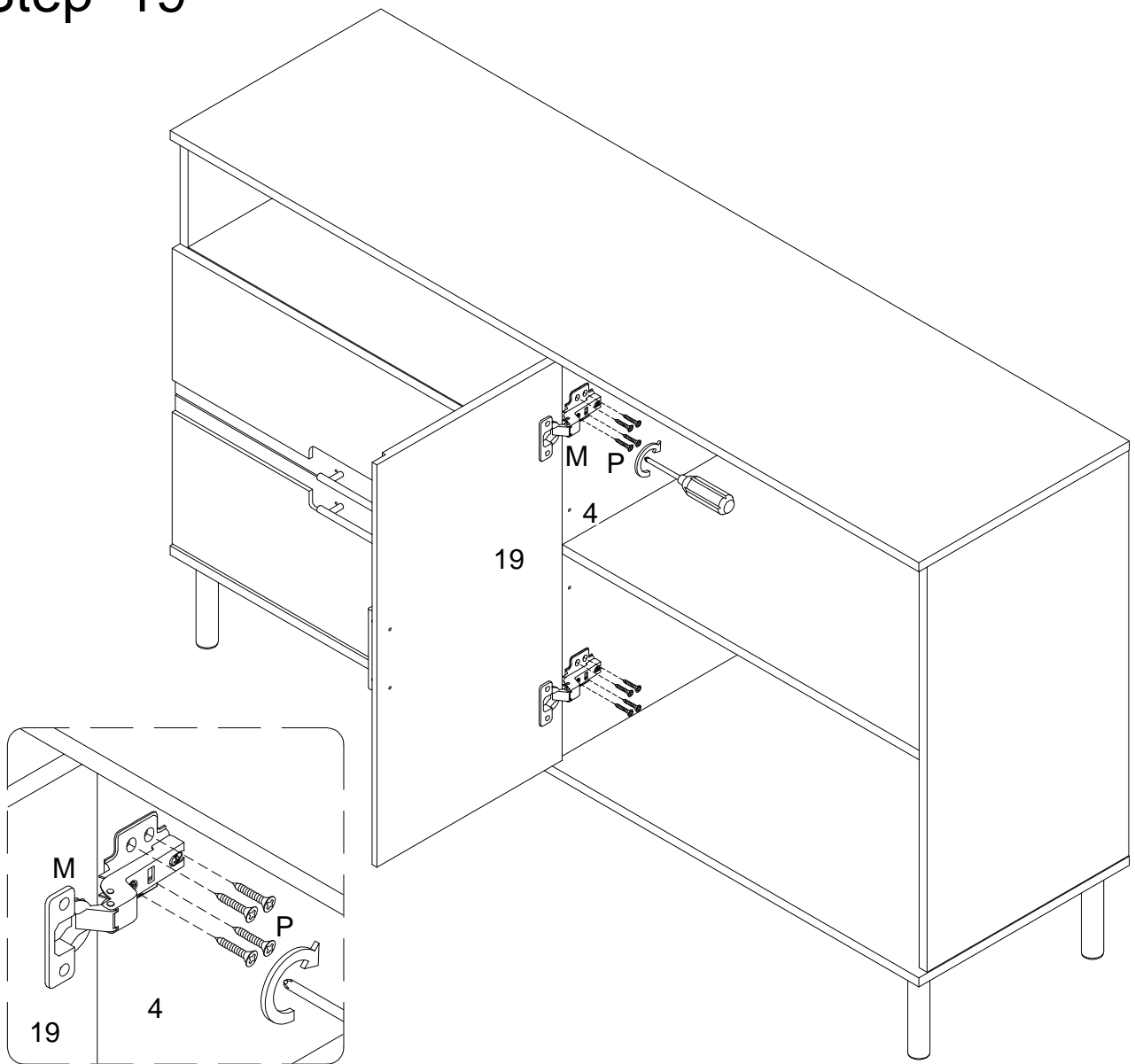

Using screw (P) attach Europe hinge (M) into part (4) with Philips head screwdriver as per diagram.

Step 20

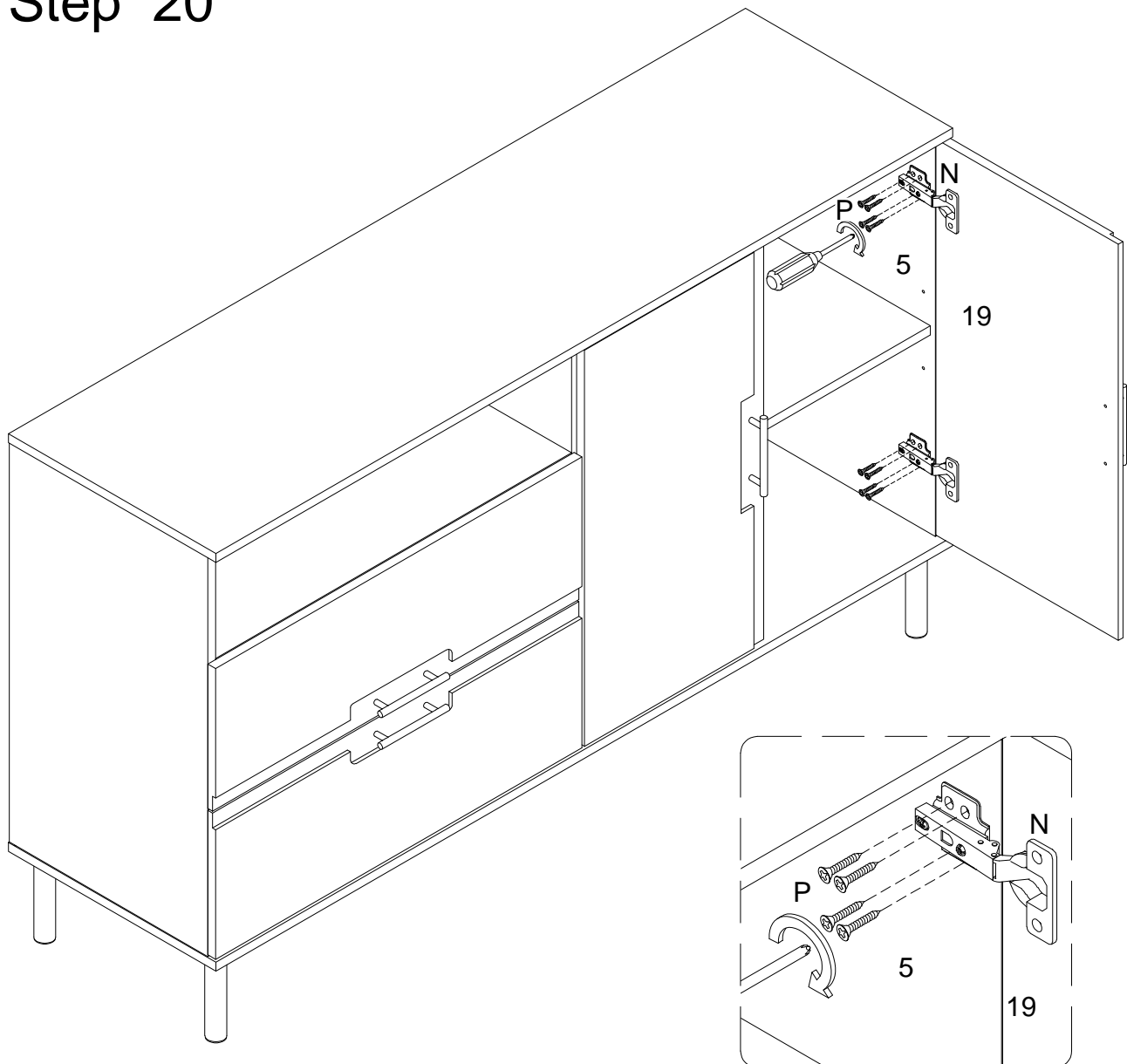

Using screw (P) attach Europe hinge (N) into part (5) with Philips head screwdriver as per diagram. Open and close the doors to make sure they were shut correctly. If necessary, adjust the screws for a good fit.

Step 21

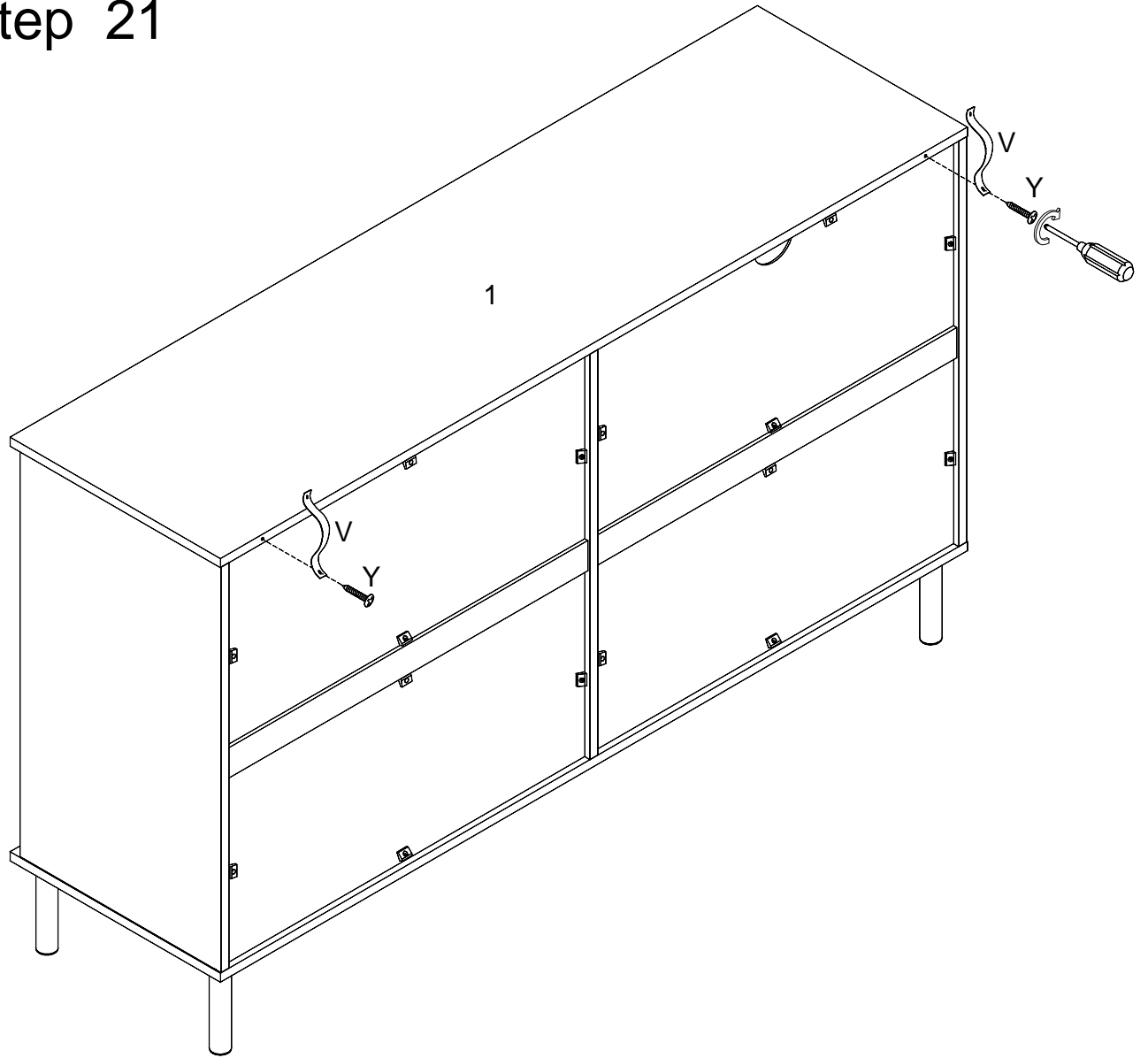

Using screw (Y) attach plastic strap (V) into part (1) with Philips head screwdriver as per diagram.

Step 22

WARNING

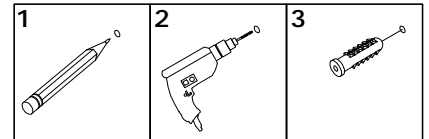

Serious or fatal injuries can occur from furniture tipping over. To prevent the furniture from tipping over we recommend that it is permanently fixed to the wall. Wall anchor and hardware are included with this product. Please make sure hardware is suitable for your walls before installing, as different wall materials may require different types of anchors.

Wall

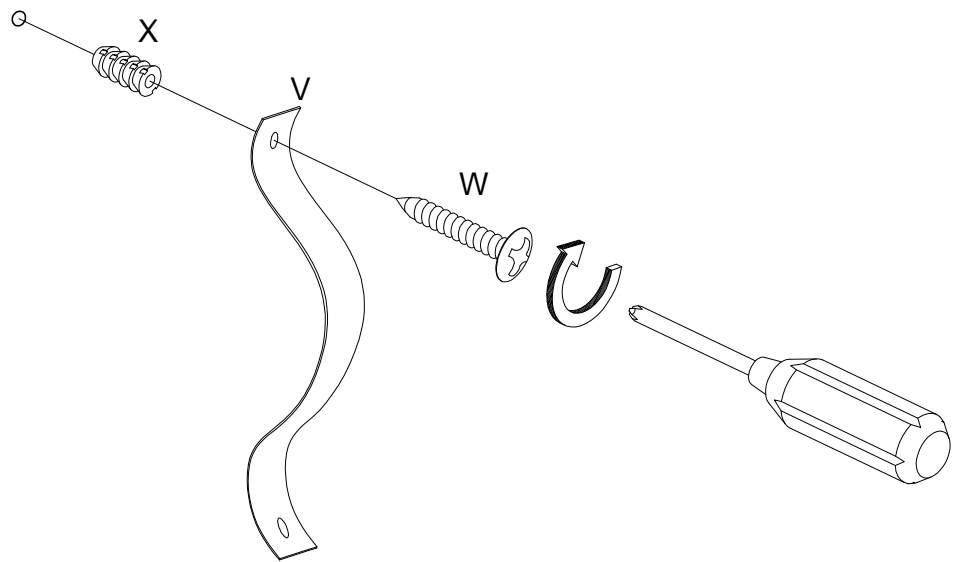

Using screw (W) attach Velcro strap (V) into Nut (X) to wall with Philips head screwdriver as per diagram.

Step 23

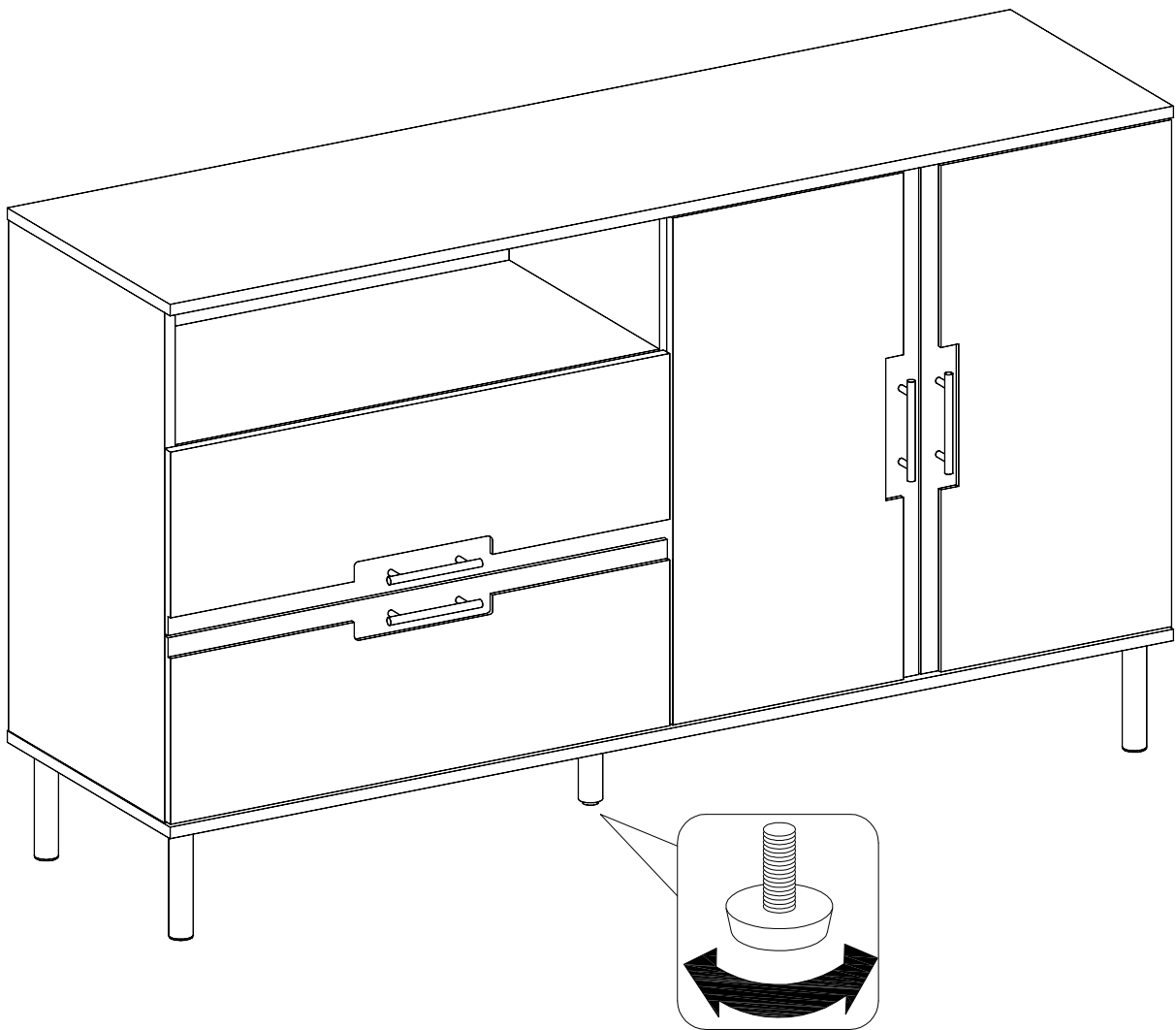

Position the assembled unit at the desired location ,if necessary adjust the floor leveler at the bottom of the support leg to level the unit .

Step 24

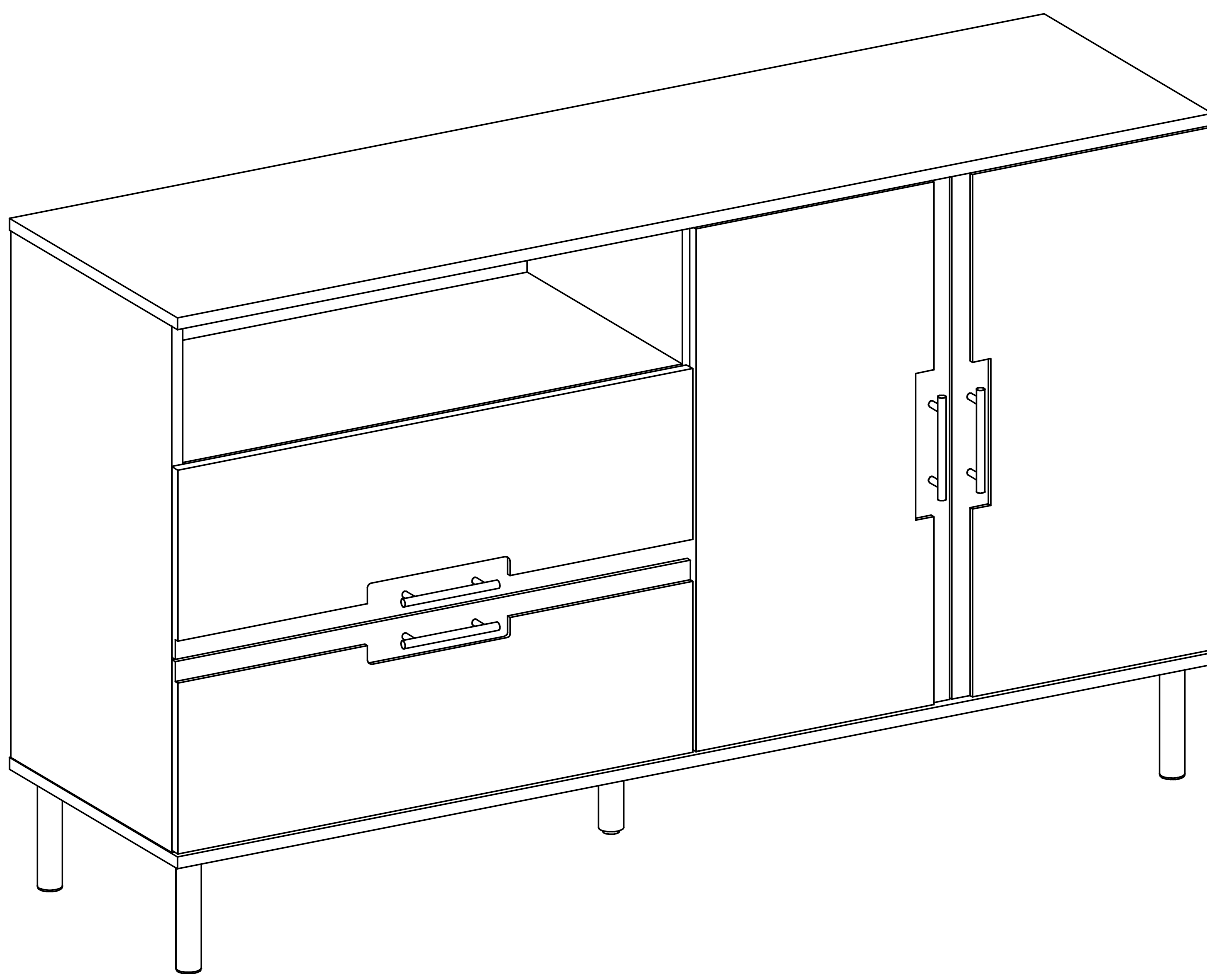

Final Assembly