

# ASSEMBLY INSTRUCTION

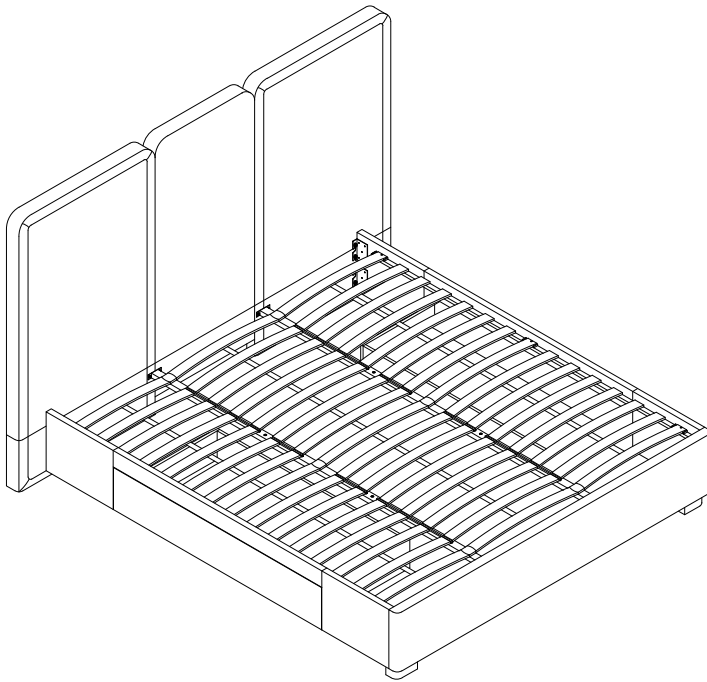

Please **TEAR OFF** this shrink film from side!  
**DO NOT USE CUTTER!**

## IMPORTANT NOTE

1. **The product is shipped in two packages. Please check the number of packages received before assembly. If you are missing one package, receive a duplicate package, or have any assembly or after-sales issues, please contact us.**
2. For the protection of your furniture, place all parts on a clean and smooth surface to prevent any damage.
3. Keep fittings out of children's reach and keep children well away from construction area.
4. When moving your assembled bed, it is best to lift the bed and never to drag it.
5. Do not use this product if parts are missing, damaged or worn.
6. This product should only be used on firm, level ground.
7. Please periodically check all fittings and re-tighten as necessary.
8. Do not use the bed unless all bolts and screws are firmly secured.
9. For further assistance, please provide a screenshot of your order and contact us.

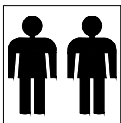

Minimum two  
person assembly

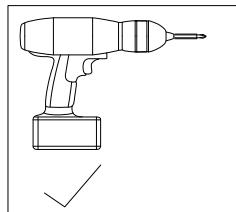

PART LIST

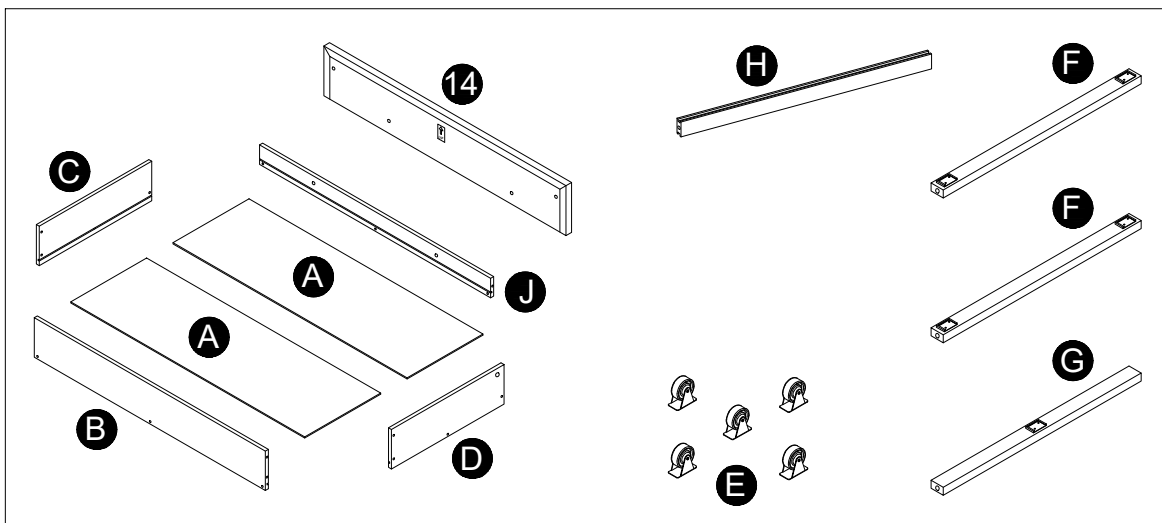
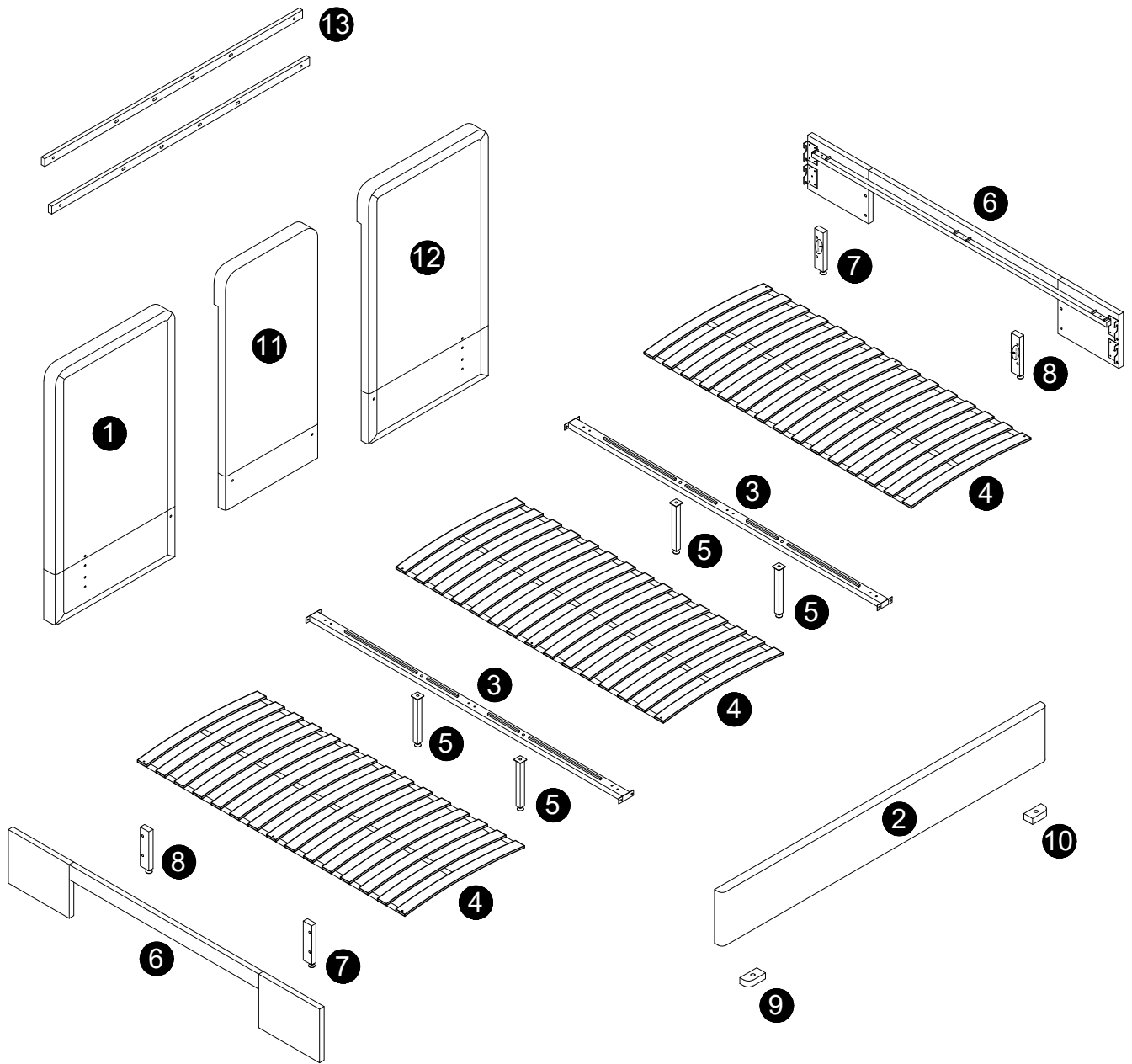





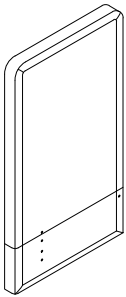
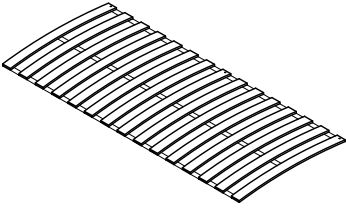
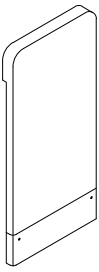
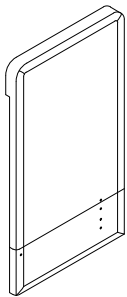
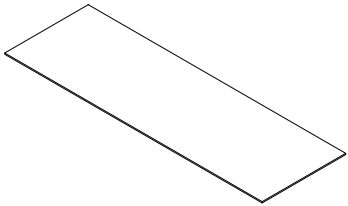
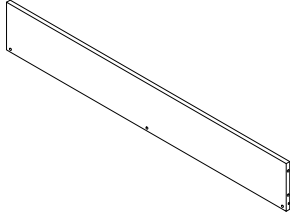
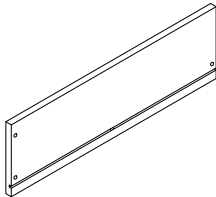
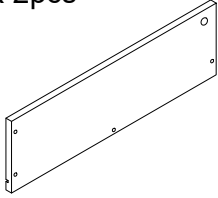
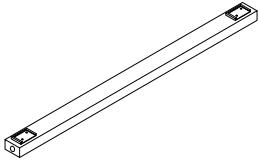
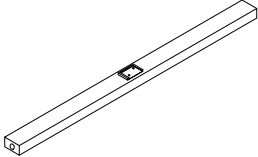
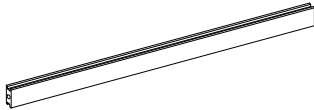
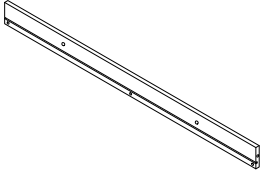

x2

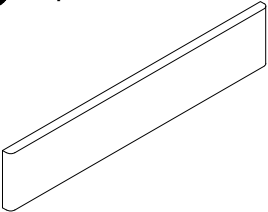
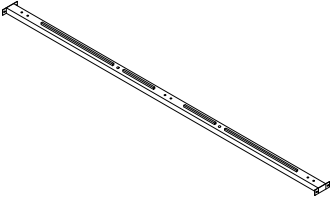
### Components of Carton A

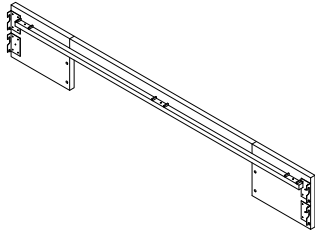
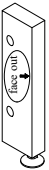
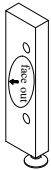

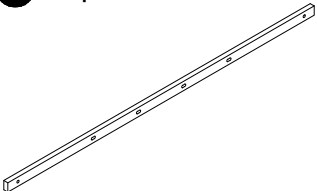
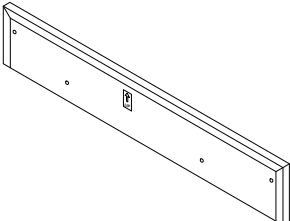









<p><b>1</b> x 1pc</p> 	<p><b>4</b> x 3pcs</p> 	<p><b>11</b> x 1pc</p> 	<p><b>12</b> x 1pc</p> 
<p><b>A</b> x 4pcs</p> 	<p><b>B</b> x 2pcs</p> 	<p><b>C</b> x 2pcs</p> 	<p><b>D</b> x 2pcs</p> 
<p><b>F</b> x 4pcs</p> 	<p><b>G</b> x 2pcs</p> 	<p><b>H</b> x 2pcs</p> 	<p><b>J</b> x 2pcs</p> 

### Components of Carton B

<p><b>2</b> x 1pc</p> 	<p><b>3</b> x 2pcs</p> 	<p><b>5</b> x 4pcs (25x255mm)</p> 	<p><b>6</b> x 2pcs</p> 
<p><b>7</b> x 2pcs (40x225mm)</p> 	<p><b>8</b> x 2pcs (40x225mm)</p> 	<p><b>9</b> x 1pc</p> 	<p><b>10</b> x 1pc</p> 
<p><b>13</b> x 2pcs</p> 	<p><b>14</b> x 2pcs</p> 	<p><b>E</b> x 10pcs</p> 	

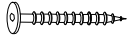
Please ensure to thoroughly inspect the small inner cardboard box containing the hardware, which are tied with a red string, before disposing of the box.

**HARDWARE LIST**

 <b>H1</b> M5 x 1pc	 <b>H2</b> M8x30mm x 16pcs	 <b>H3</b> M8x50mm x 26pcs	 <b>H4</b> M8x40mm x 12pcs
 <b>H5</b> M8 x 20pcs	 <b>H6</b> M8x22mm x 20pcs	 <b>H8</b> x 6pcs	 <b>H9</b> x 6pcs
 <b>H10</b> M6x45mm x 28pcs	 <b>H11</b> M4 x 1pc	 <b>H12</b> x 4pcs	 <b>H13</b> x 4pcs

**1**

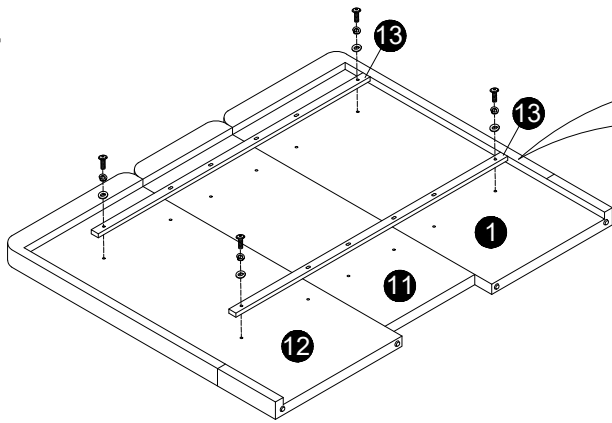

**80%**

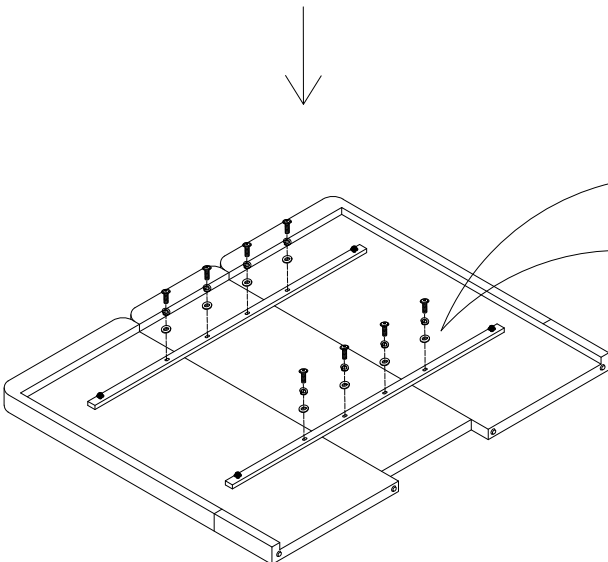

**100%**

**Fully tighten all fixings.**

2

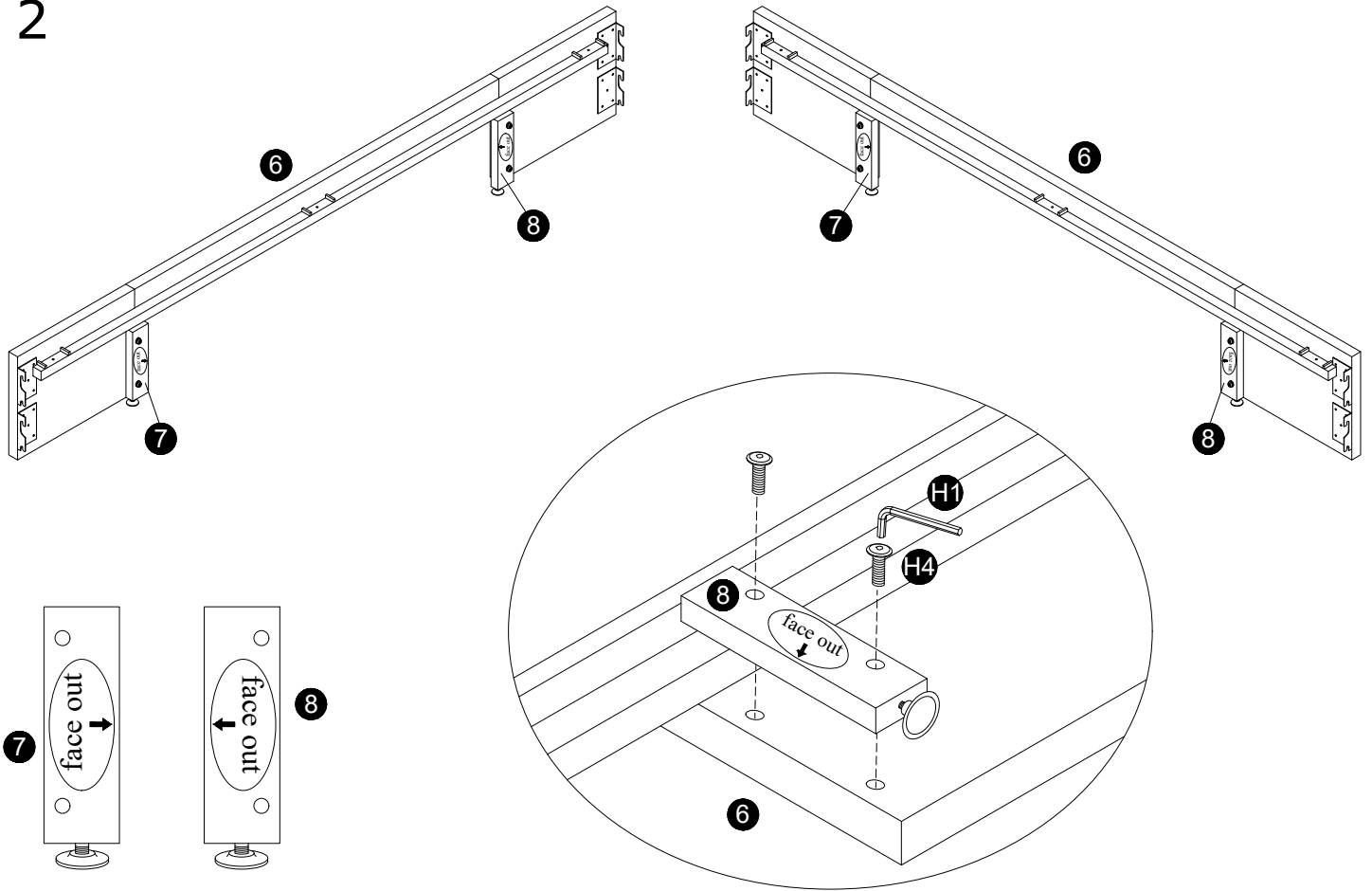

3

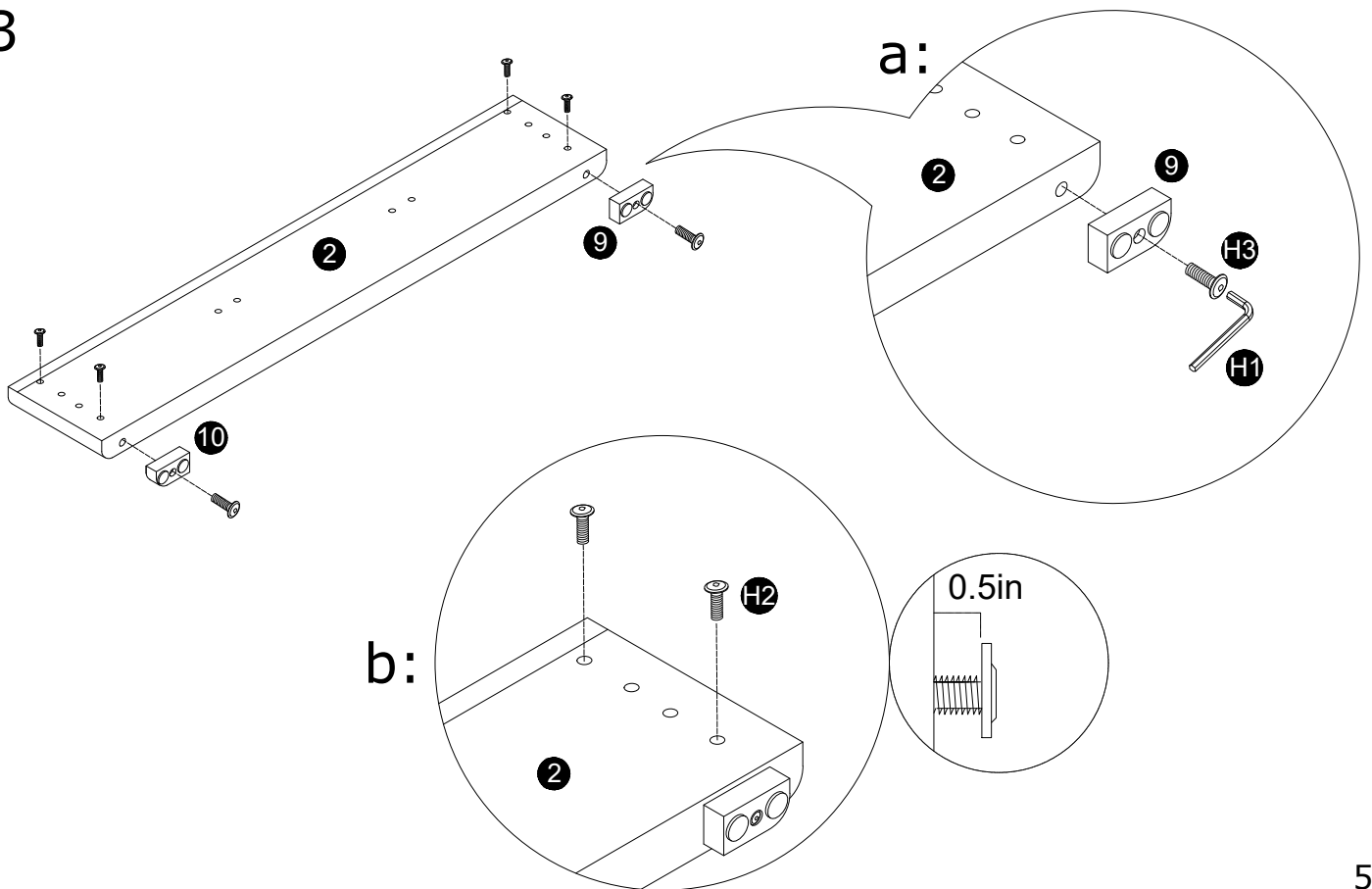

4

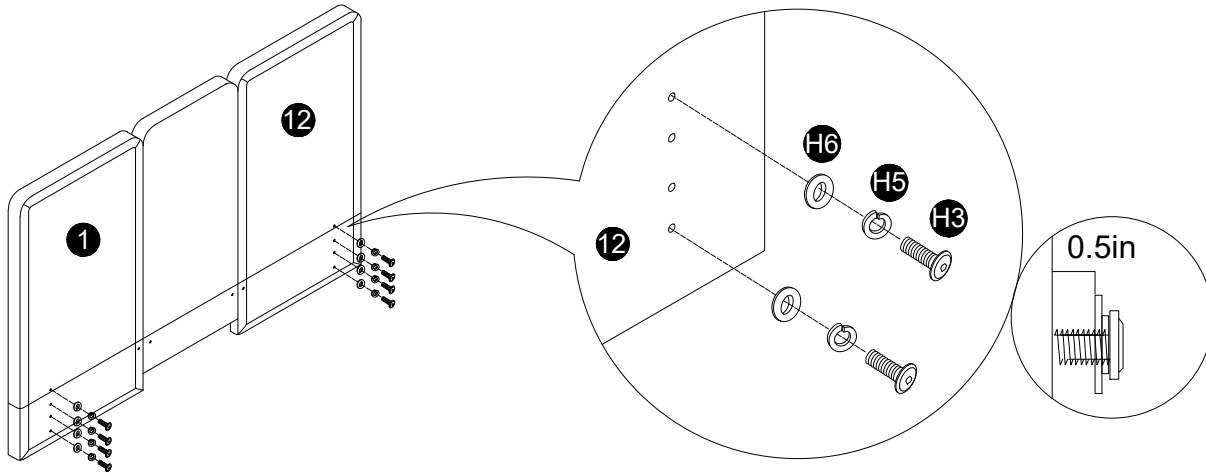

5

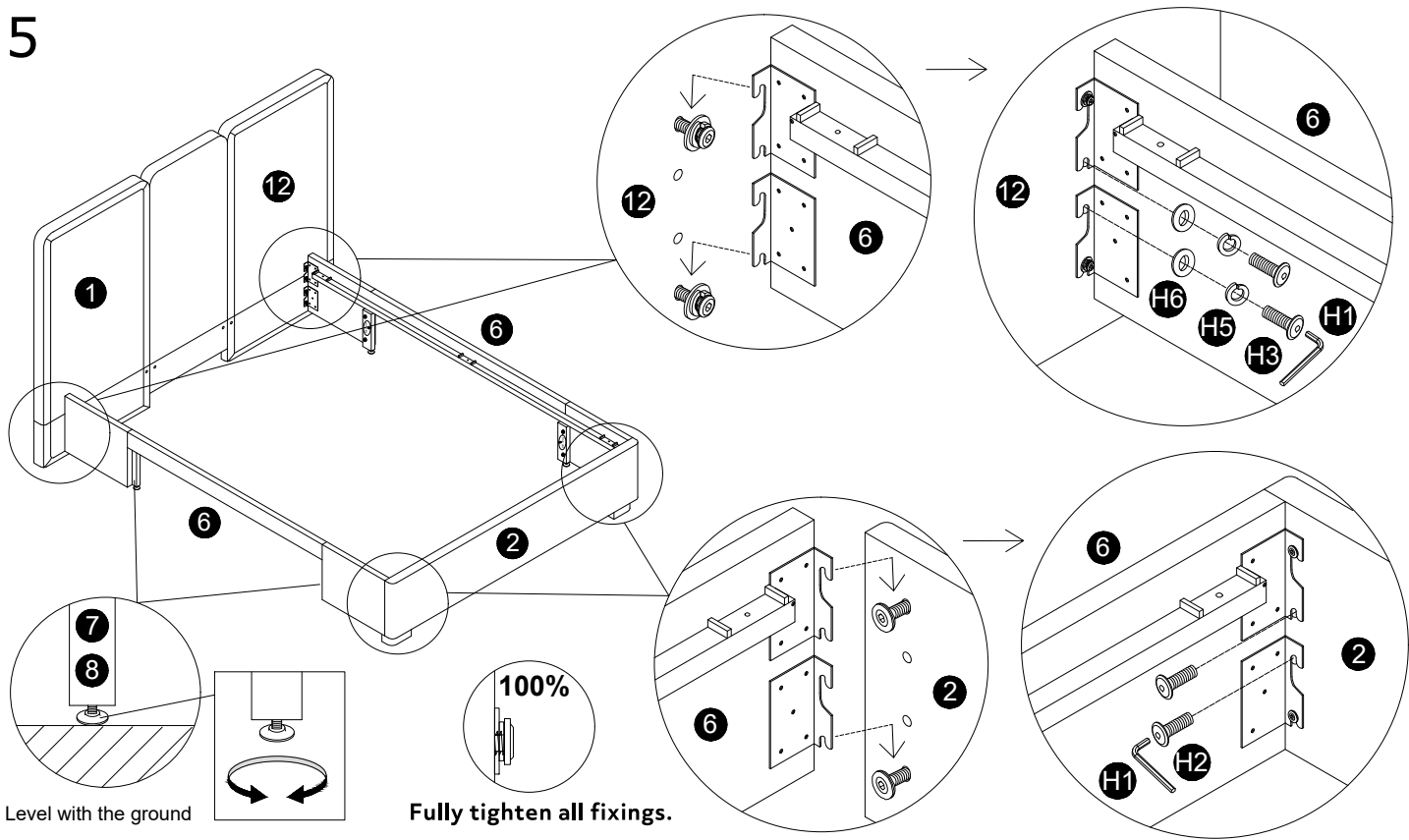

6

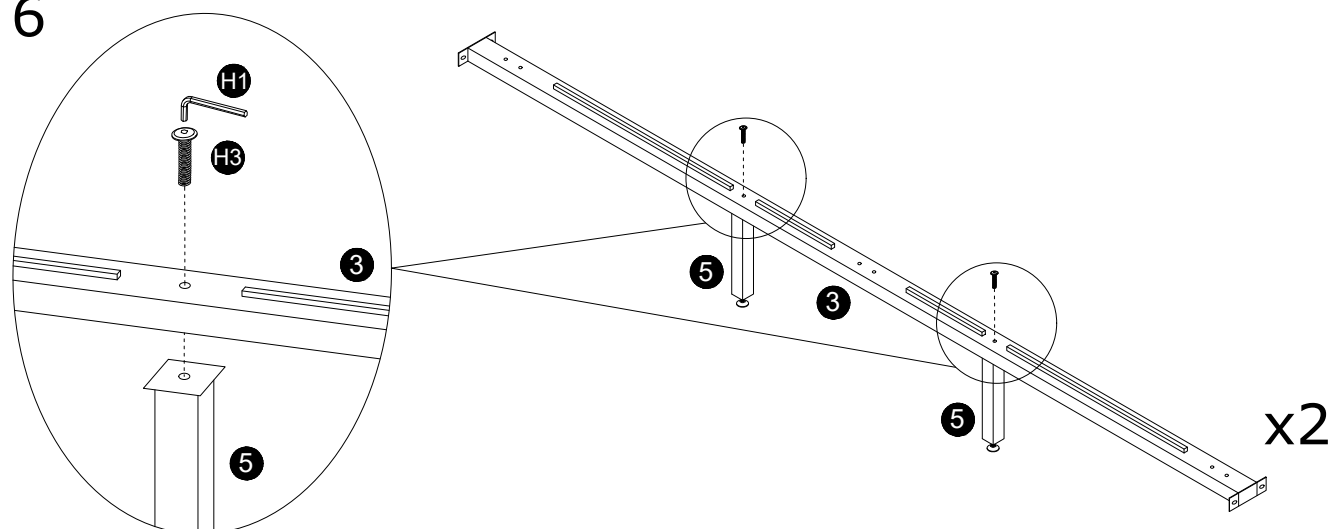

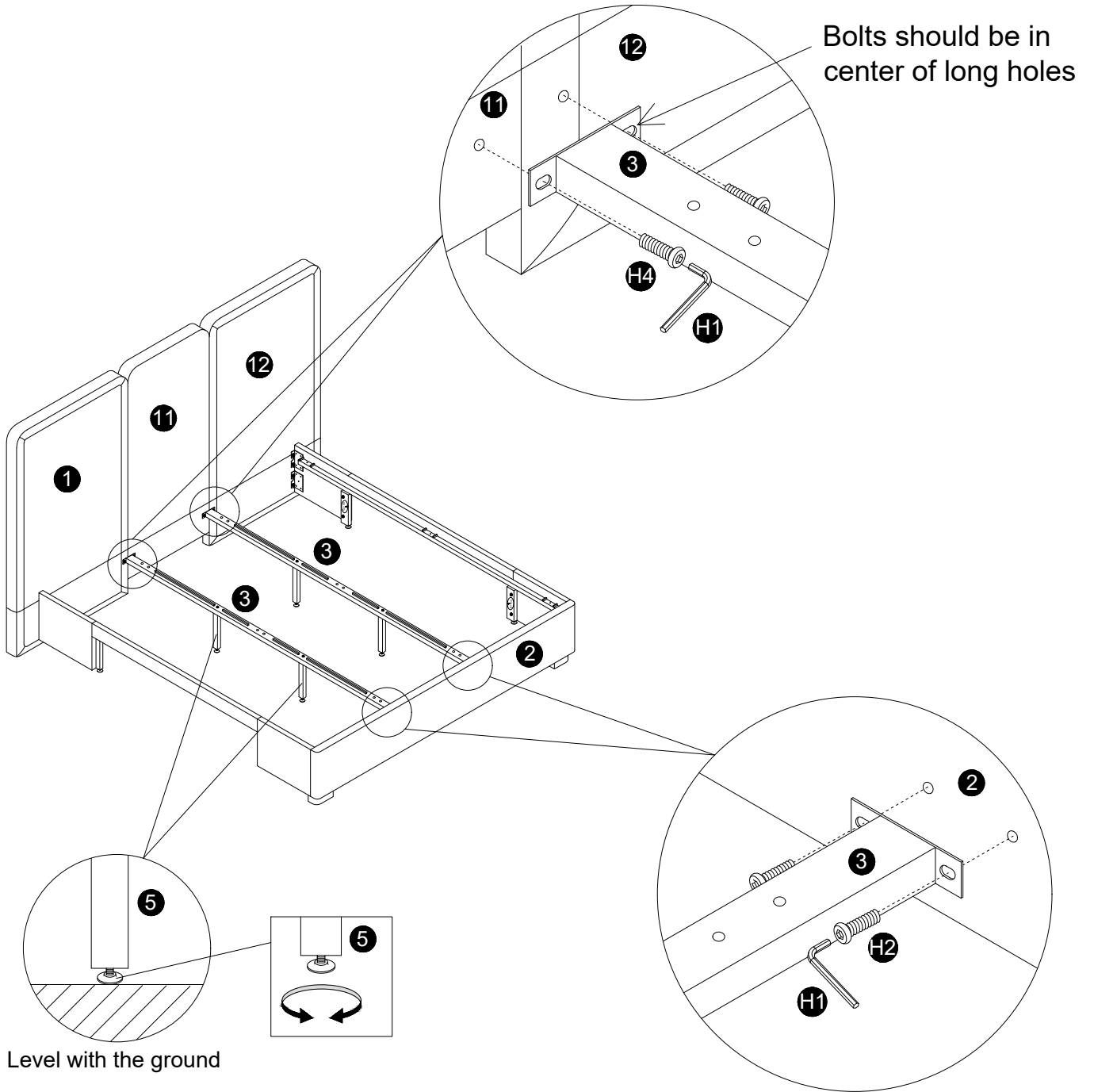

8

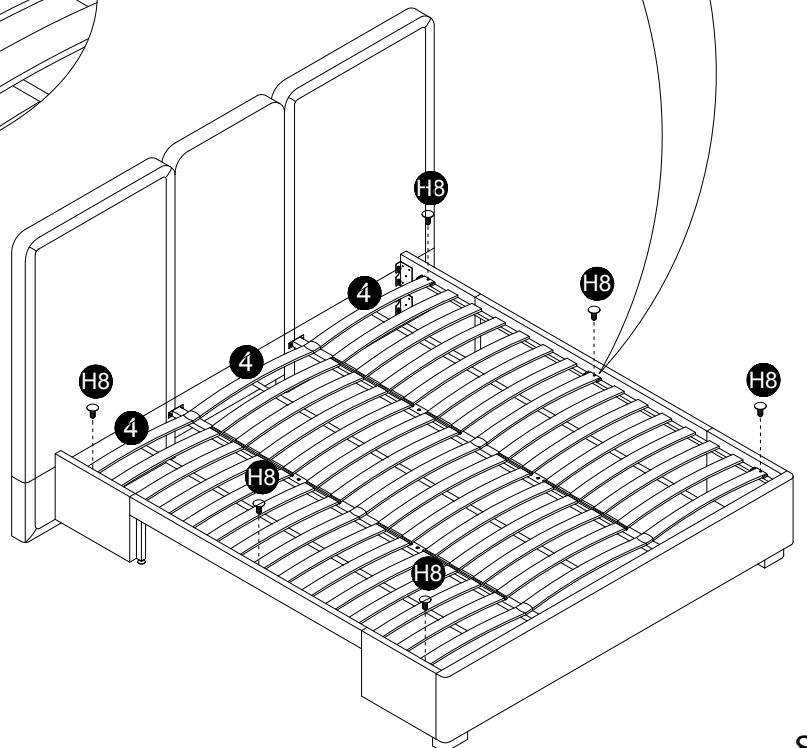
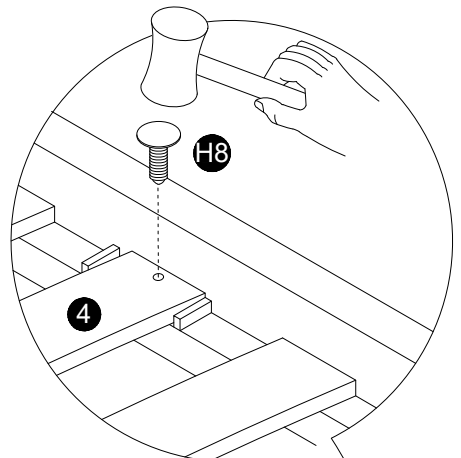
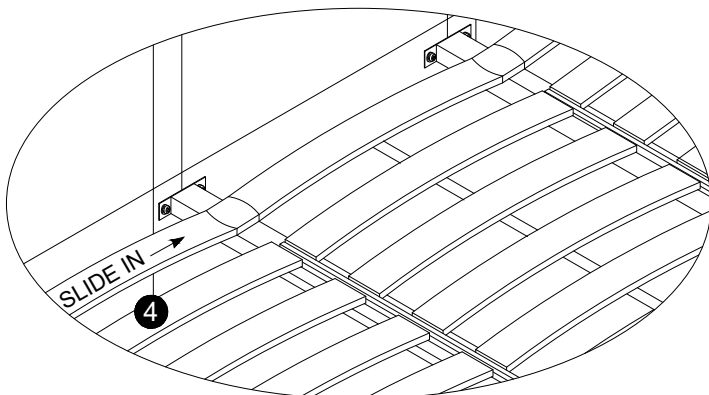
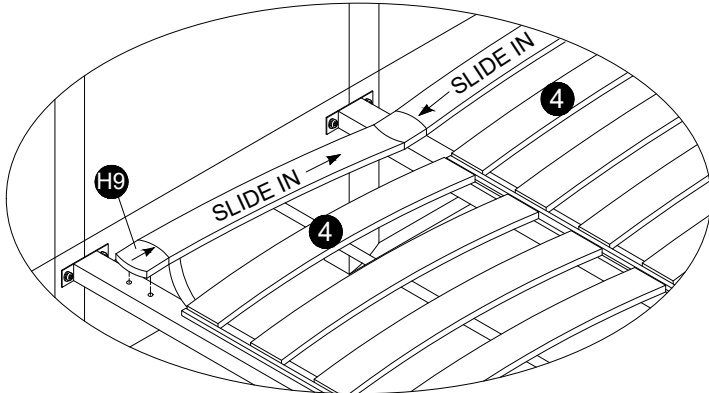
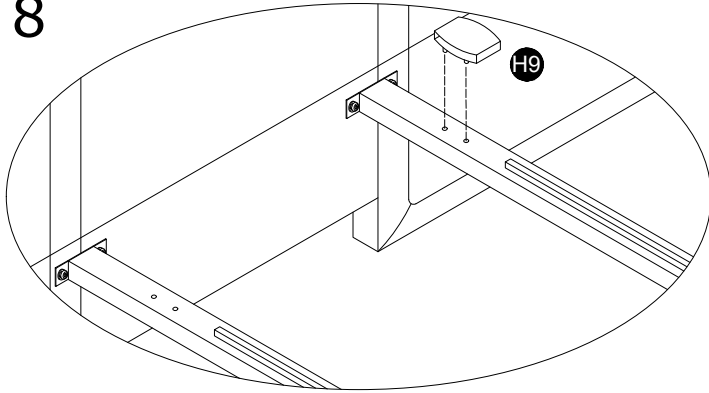

9

Grooves to align

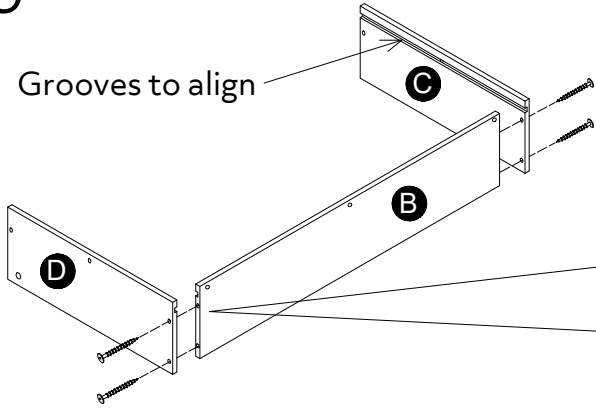

x2

10

a:

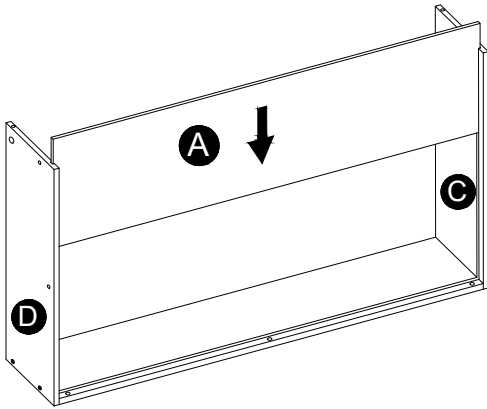

x2

b:

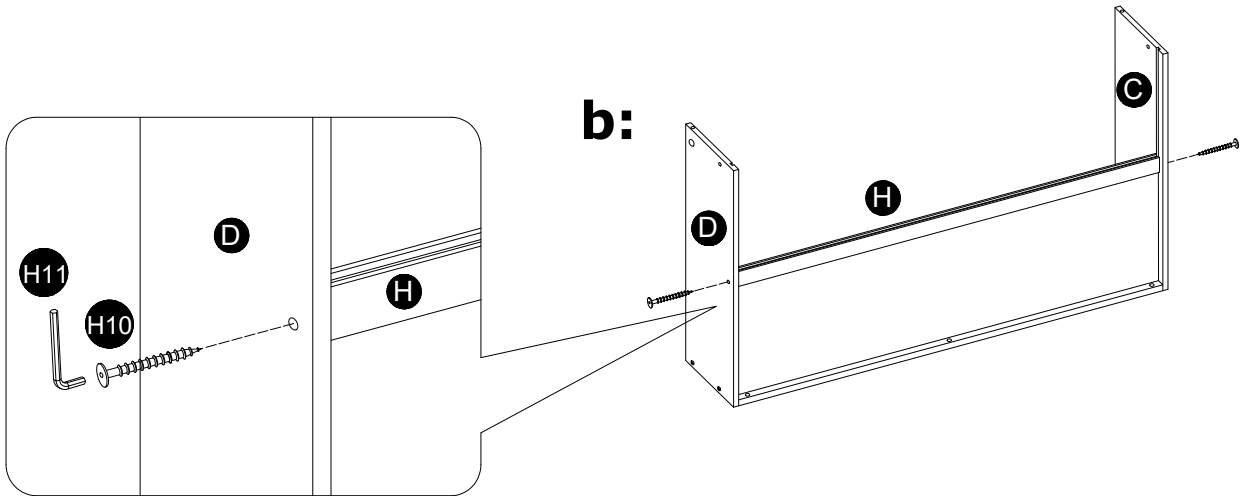

c:

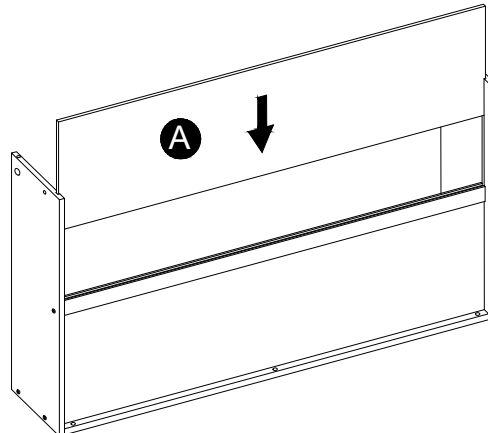

11

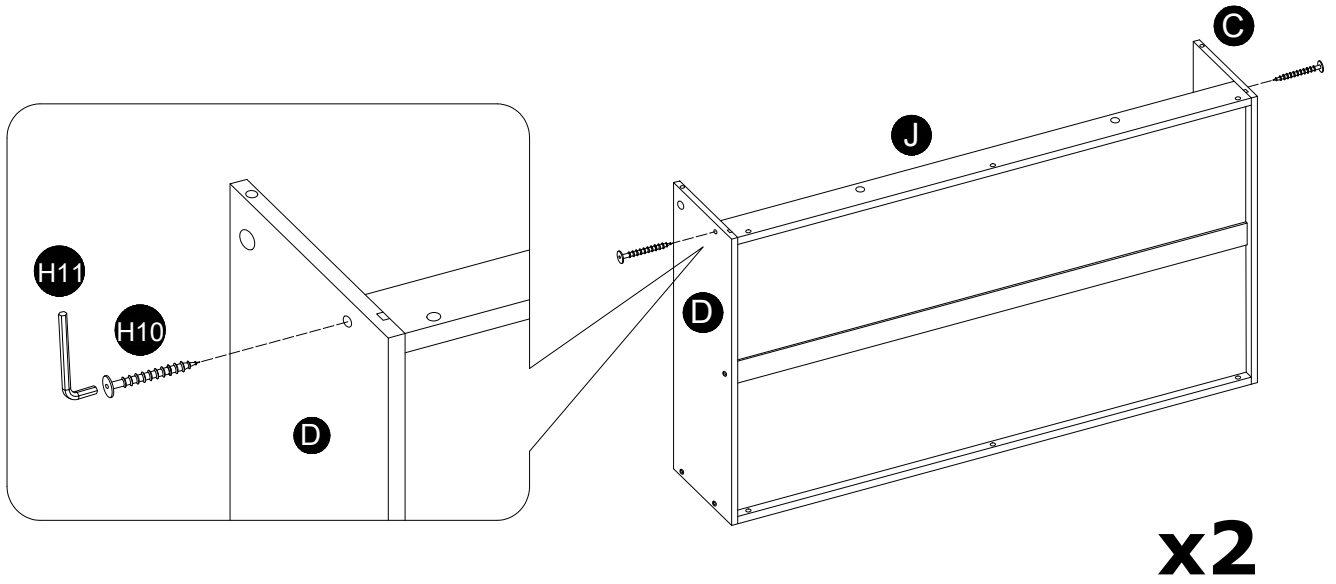

12

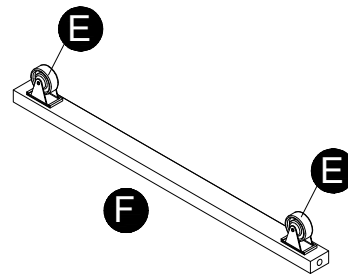
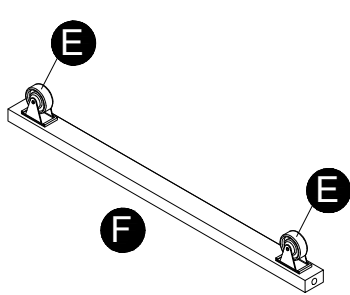

x2

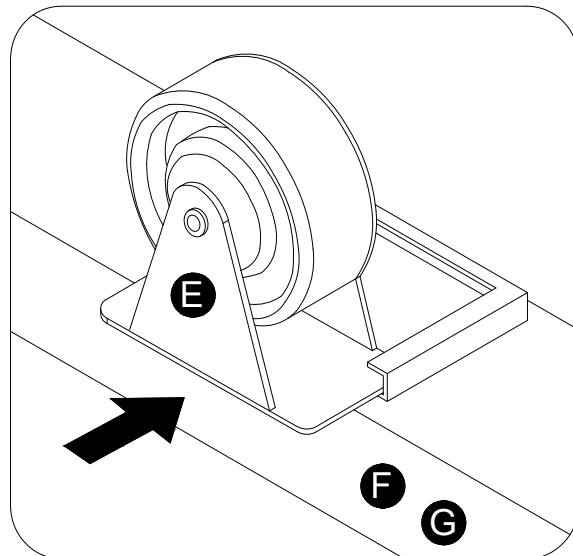
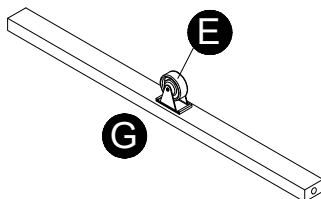

13 **x2**

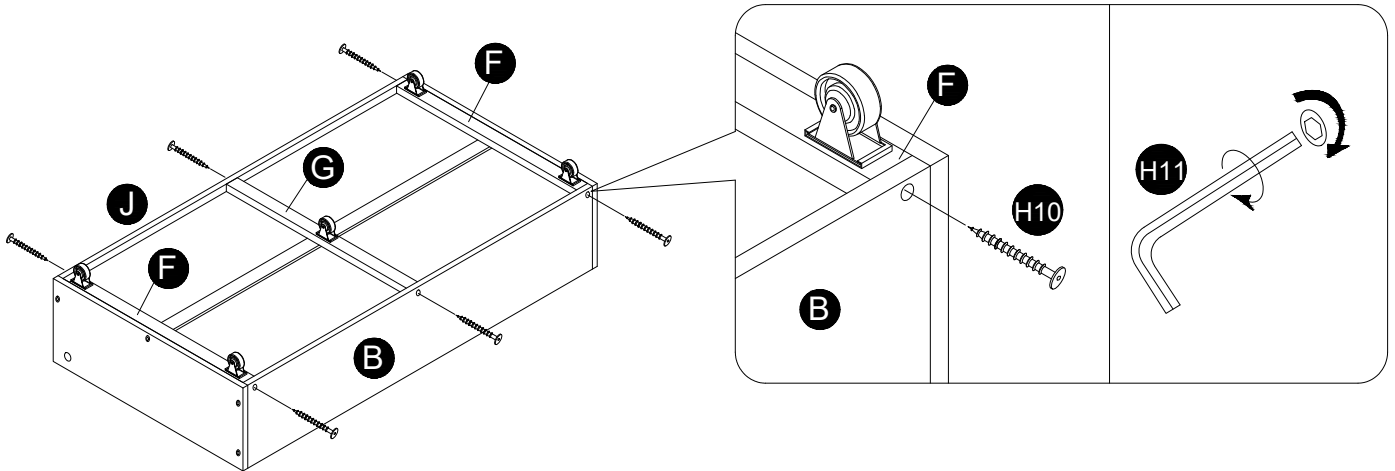

14 **x2**

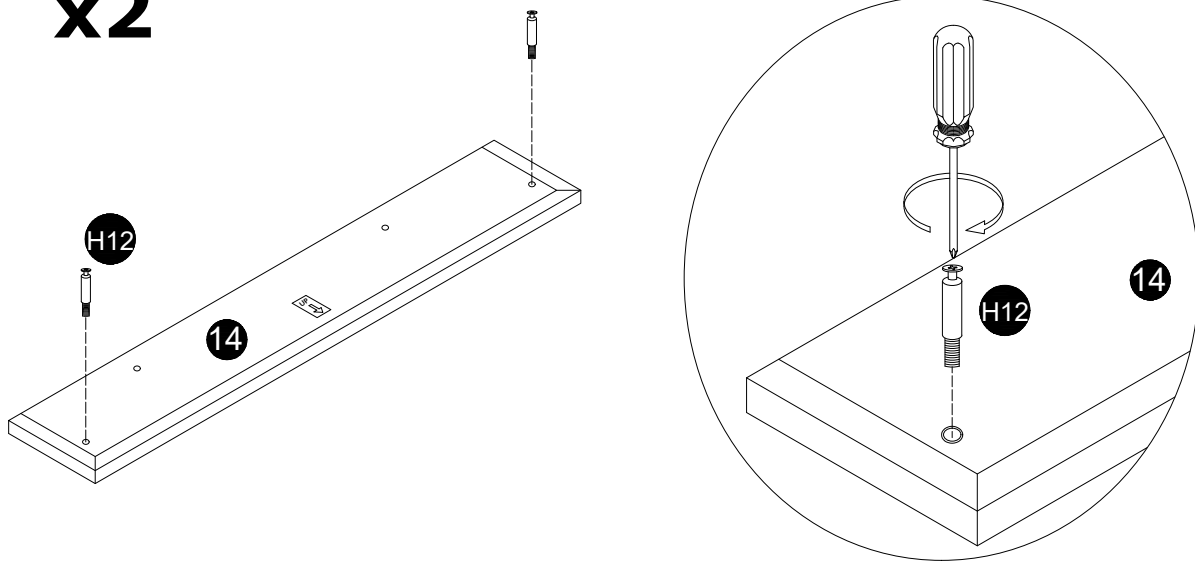

15 **x2**

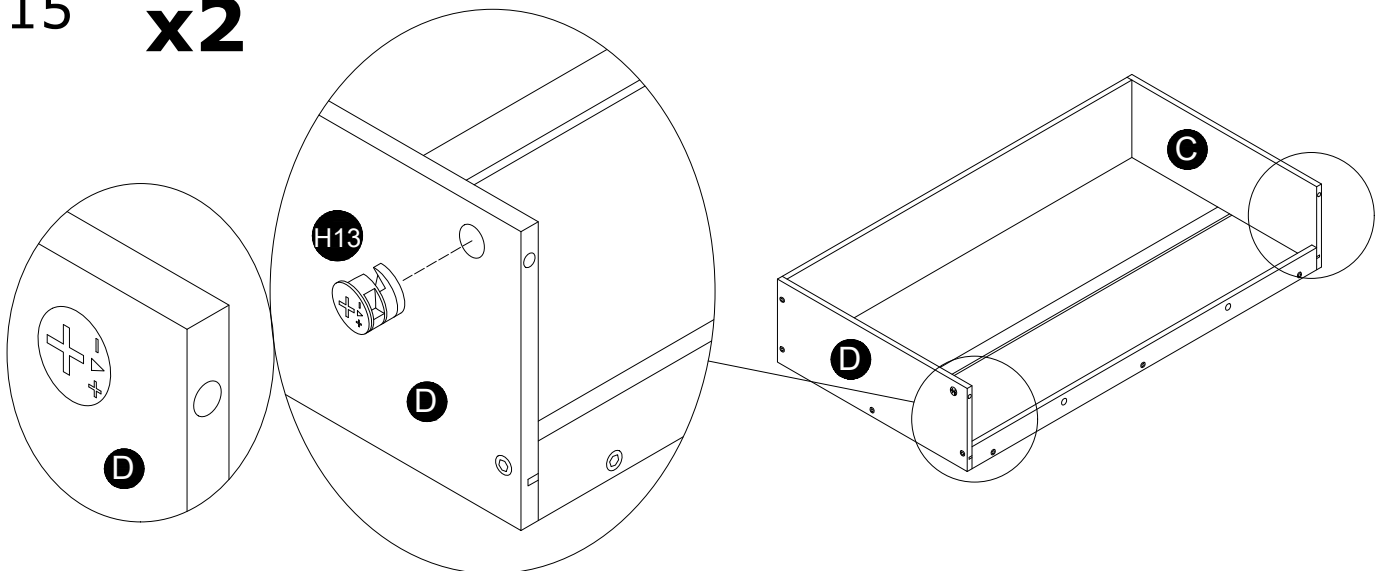

16 **x2**

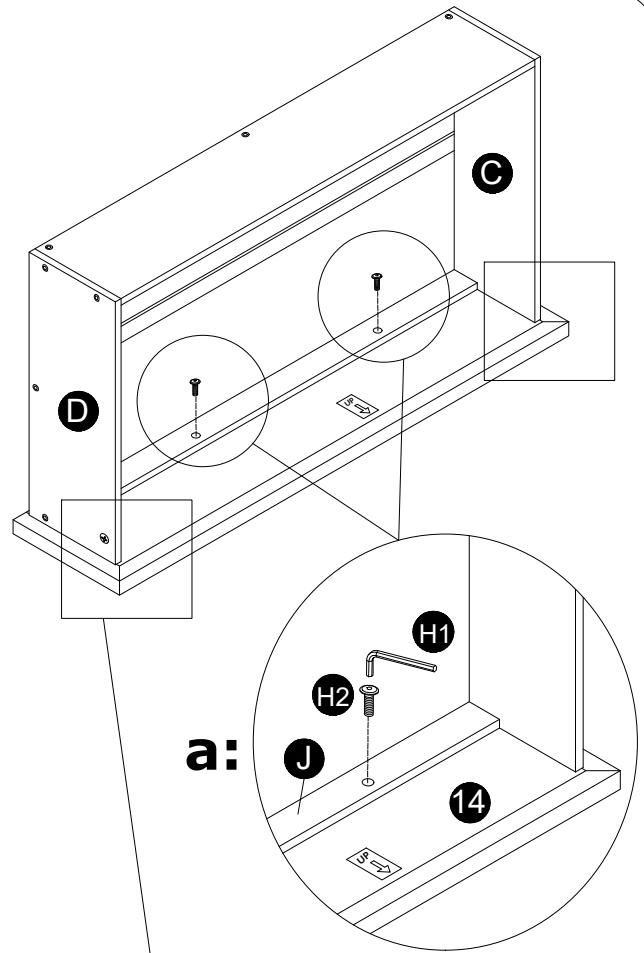
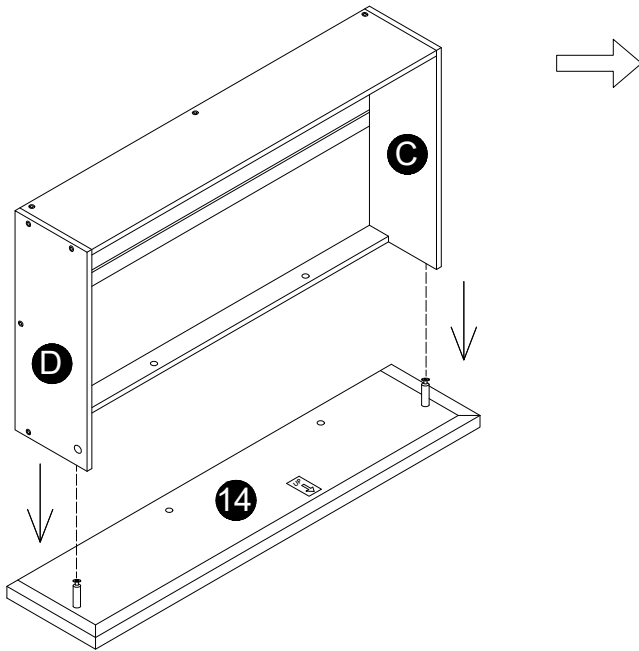

PUSH THE TWO PANELS TOGETHER ALLOWING THE DOWEL TO ALIGN WITH THE HOLE

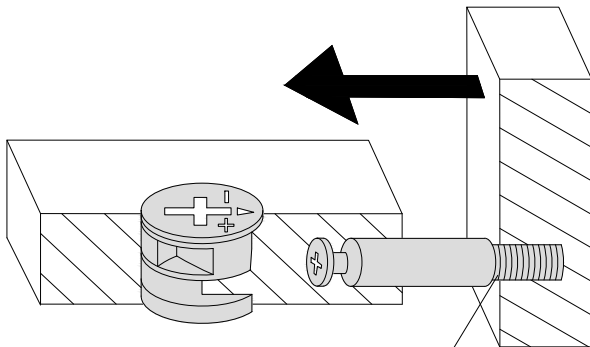

If H12 cannot lock into H13, you can adjust H12 outward by 2mm.

TURN THE CAM IN A CLOCKWISE DIRECTION

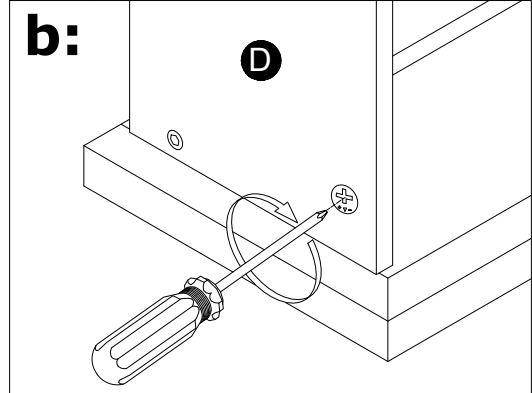
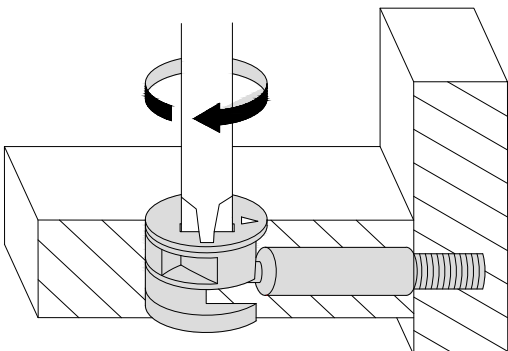

**DON'T STOP UNTIL THE 2 O'CLOCK LOCK**  
TURN THE CAM IN A CLOCKWISE DIRECTION UNTIL THE ARROW POINTS IN THE POSITIONS SHOWN IN THE DIAGRAMS BELOW

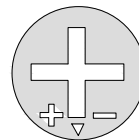

OPEN

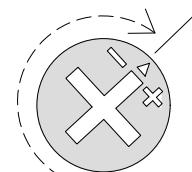

LOCKED

**Job Complete !**

*In the interest of our environment please dispose of all packaging thoughtfully.*