













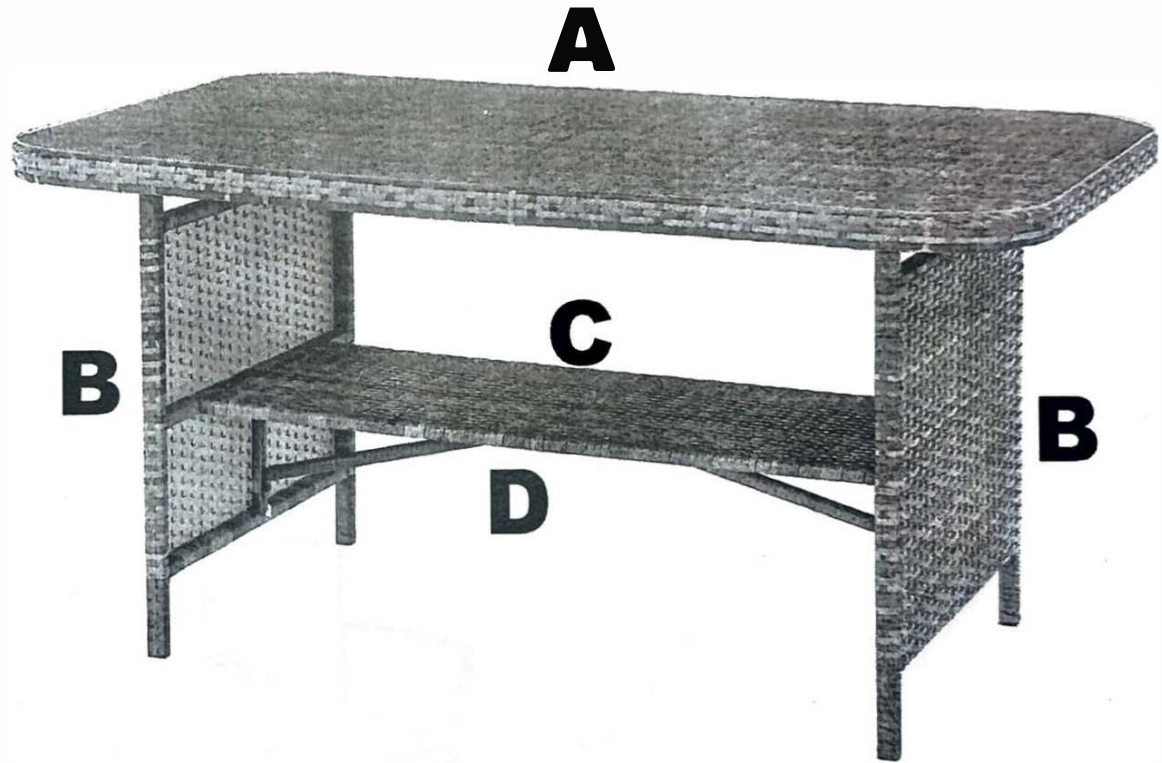

# Installation & Assembly

NO.	PART	QTY
<b>A</b>		<b>1</b>
<b>B</b>		<b>2</b>
<b>C</b>		<b>1</b>
<b>D</b>		<b>1</b>
<b>E</b>		<b>1</b>
	 M6x35	<b>5</b>
	 M6x15	<b>6</b>
		<b>11</b>







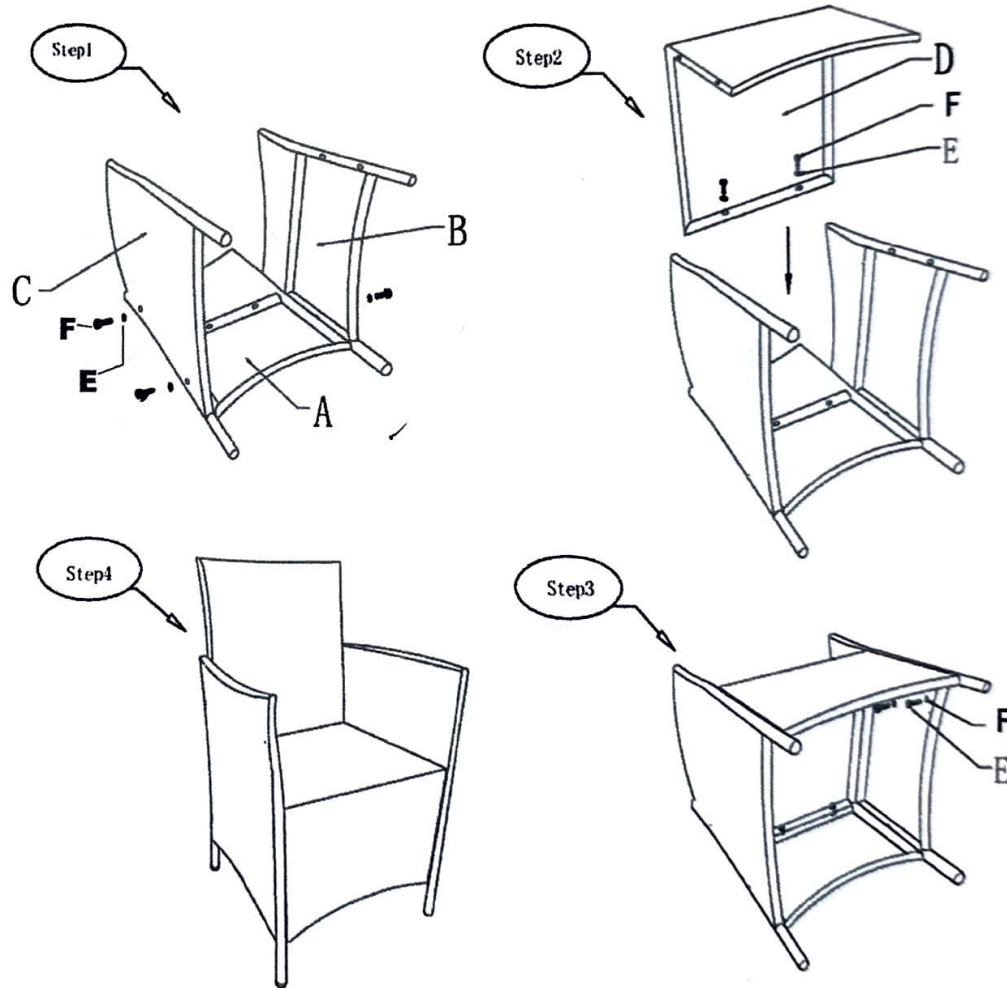

No.	PARTS	QTY PCS
A		1
B		1
C		1
D		1
E		10
F	 M6x30	10

**Assembly Tip:**

First fit all screws loosely in each chair/sofa/table parts. Once all parts have been put together then slowly tighten all screws. We recommend two persons working together to assemble the set.

**CHAIR ASSEMBLY**



No.	PARTS	QTY PCS
G		1
B		1
C		1
H		1
E		11
F	 M6x30	11

**Assembly Tip:**

First fit all screws loosely in each chair/sofa/table parts. Once all parts have been put together then slowly tighten all screws. We recommend two persons working together to assemble the set.

**SOFA ASSEMBLY**

