

JZONVYD9WDML8 F型手摇带式电阻成型机 101F(立式编带)-手摇立式F型 说明书 英语

Hand-Operated Belt Resistance Molding Machine (RJ-301F Model) Instruction Manual

Please read this manual in detail before installation and use, and save it for future reference.



I Packing List

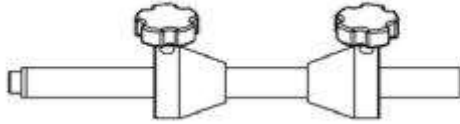

(1)



(2)

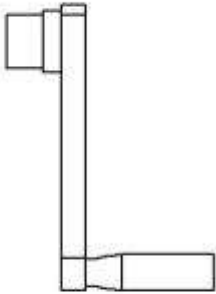

(3)

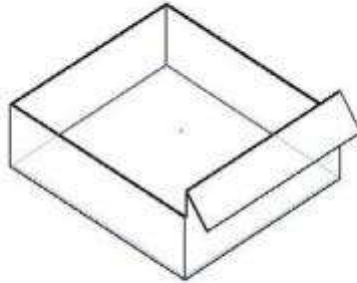

(4)



(5)

Serial Number	Annex Name	Unit (Piece/Set)
1	Main Machine	1
2	Crank	1
3	Support Bar	1
4	Hanging Rod	1
5	Material Box	1
6	Hex Key	1
7	Instruction Manual	1
8		

II Product Structure:

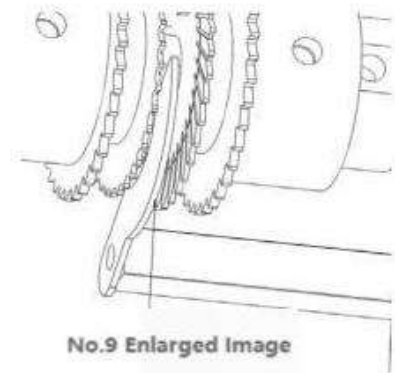
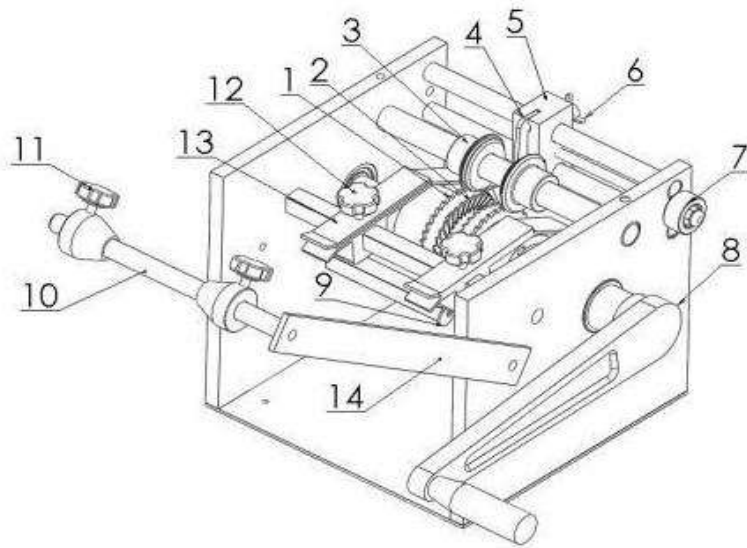

Serial Number	Part Name	Serial Number	Part Name
1	Cut Off Gear	9	Ejector
2	Forming Gear	10	Hanging Bar
3	Circular Knife	11	Plum Knob
4	Forming Sheet	12	Plum Knob
5	Forming Sheet Fixed Aluminum Seat	13	Feeding Clamp
6	Butterfly Screw	14	Support Bar
7	Adjusting Rod	15	
8	Crank	16	

		F-Type
	A	4~15mm
	B	2~15mm
	C	3mm
	D	1.5~6mm
	W	0.35~1mm
	H	25mm

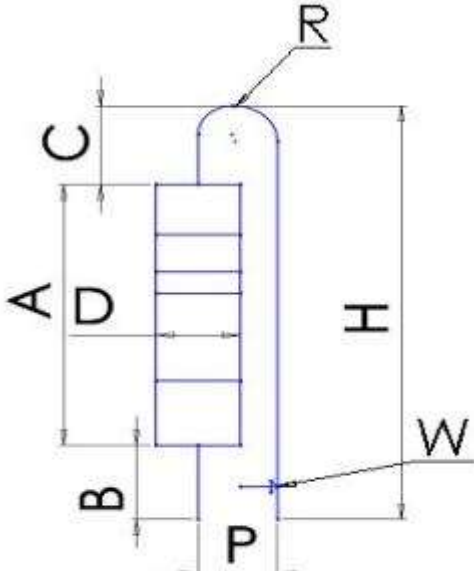
	P	4~13.5mm
---	---	----------

(Forming Parameters)

III Product Parameters:

Product Category: Resistor / Diode Processing Molding Foot Cutting Machine

Product Name: Hand Crank with Resistance Forming Machine - F type / RJ-301F

Voltage: 110V-220V AC 60Hz/50Hz

Weight: 12Kg

Machine Size: L200xW185xH200(mm)

IV Product Overview:

1. Suitable for braiding tape resistors, diodes and other electronic components forming and cutting feet.
2. Forming and cutting the foot at one time and the foot length and span can be adjusted.
3. Easy to operate and adjust, suitable for mass production.
4. The machine is hand-crank type without power supply which is low cost.
5. Different shapes of forming gear have different shapes, F shape.

V Installation Instructions:

1. Before installation and use, please check the packing list and read this manual carefully.
2. Take out the machine. Put it on the flat table and fix it.
3. Take out the crank. Use the supplied hex key. Install the crank, turn the crank so that all the rotating gears of the machine can operate normally.
4. Install the support bar and hanging bar (as shown in the structure).

VI Operating Instructions:

1. Loosen the plum knob on the feed clamps (13). Move the two feed clamps axially from left to right to both sides of the machine (shown in Figure 1).

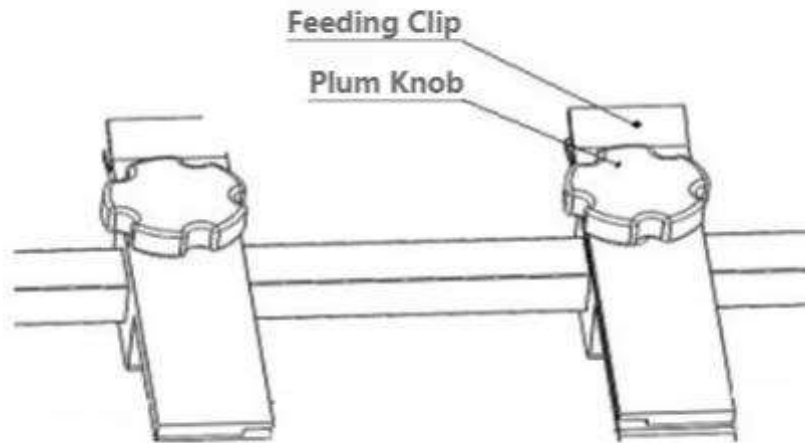

Figure (1)

2. Loosen the set screw on the forming gear (Fig. 2) with the hex key, and the two forming gears move closer to the forming sheet (Fig. 3), the clearance between the forming sheet and the forming gear is slightly larger than the wire diameter of the part. The ejector and forming sheet is located in the middle of the two forming gears. The clearance between the two sides of the forming sheet is slightly larger than the wire diameter of the part to avoid damaging the part during forming. (If the forming sheet is not centered in the forming gear, please adjust the lever on the side of (Fig. 4) to adjust the centering of the forming sheet.)

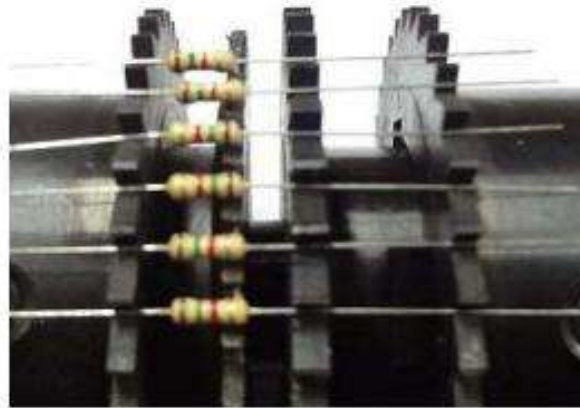

Figure (2)

3. Loosen the set screws on the cut-off gear (Fig. 2) with the hex key, and move it axially from side to side so that the distance between the cut-off gear and the forming gear is the required size ("B" in the product parameters) and then tighten the set screws on the cut-off gear.

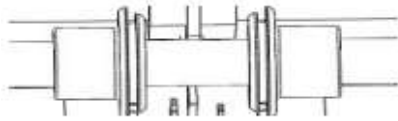

Figure (3)

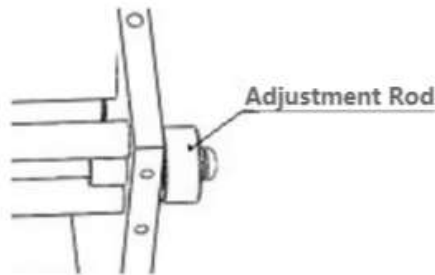

Figure (4)



Figure (5)

4. Adjustment of Span: There is a hexagonal screw (Figure 5) on the forming sheet fixed aluminum seat to adjust the span ("A" in the product parameters). When the hexagon socket screws are rotated clockwise, the smaller the span of the part formed, and the larger the span when rotated counterclockwise.

Note: The ejector must be located in the middle of the two gears, otherwise it will affect the material release.

When adjusting, please refer to the structure diagram and illustration.

5. Place the braiding element on the hanging rod, adjust two feed clamps, so that their width is the same as the width of the braiding element, and make the braiding element passes through the slot in the feed clamps (Figure 1). Tighten the plum knob on the feed clamps.

6. The element is placed between the forming and cutting gear (Figure 6)

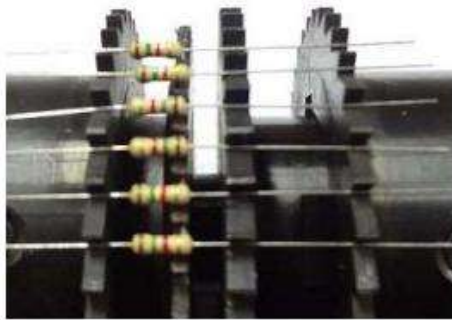

Figure (6) Correct

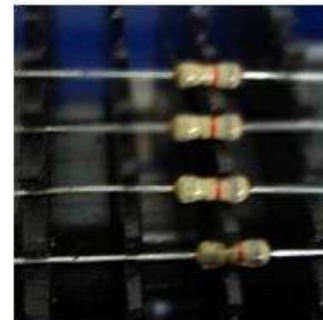

Figure (7) Incorrect

7. After the above method is completed, the crank can be rotated at a uniform speed so that the components are fed into the cutting gear and round knives one by one following the forming gear for processing, and then the forming gear and forming sheets complete the forming process, and the processed components fall into the material box through the rewinders until all components are processed.

VII Caution:

1. When using this machine. You should check whether all the fastening screws are tightened.
2. Cutting gears, forming gears, circular knives and forming sheets are all heat-treated parts, which should avoid breakage by mutual impact.
3. The bending gap should be adjusted according to the size of the component pin wire diameter. It is normal for the pins of the components to be slightly flattened, and the copper should not be

exposed.

4. The body of the component is strictly prohibited to bite into the gear to avoid gear breakage (Figure 8)



Figure (8) Incorrect

VIII Machine Maintenance:

1. After each process, please remove the waste in time.
2. Forming wheel shaft and cutter wheel shaft should be lubricated with a little 40# oil every 3-5 days to keep them lubricated.
3. When not working for a long time, each part should be coated with a small amount of oil to protect, wipe off before use.