

# TWO STATION DRAWING TABLE

DT-80A, DT-82A, & DTA-21A  
ASSEMBLY INSTRUCTIONS

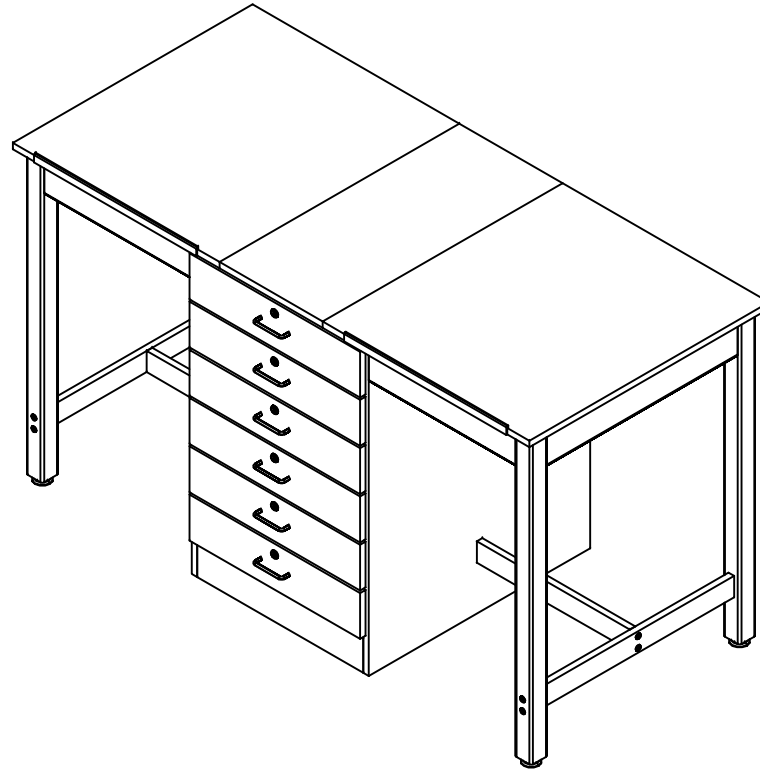

**NOTE:**

1. MODEL VIEWS MAY NOT REPRESENT EXACT MODEL PURCHASED

DWN BY:	EMK	DWN DATE:	1/7/15
APR BY:		DATE APR:	
APR BY:		DATE APR:	

UNLESS OTHERWISE SPECIFIED  
DIMENSION ARE IN INCHES  
CABINET SQUARENESS ± .0625  
FRACTIONAL VALUES ± 1/32"  
- ALL VALUES ± OVERALL -



300 South Krueger Street  
Suring, WI 54174  
diversifiedwoodcrafts.com

TITLE:  
TWO STATION DRAWING TABLE  
ASSEMBLY INSTRUCTIONS

REV.	DESCRIPTION	DATE	NAME	ECH NO.
A	CREATED ASSEMBLY INSTRUCTIONS	1/7/15	EMK	-
REVISION LEVEL				

THIS DRAWING IS THE SOLE PROPERTY OF  
DIVERSIFIED WOOD CRAFTS. IT MAY NOT  
BE ALTERED OR CHANGED WITHOUT  
PERMISSION

DRAWING NUMBER:	SCALE:	SHEET:	REVISION:
DT-80A, DT-82A, & DTA-21A	NTS	1 OF 10	REV A

## TOOLS REQUIRED

1/2" WRENCH
1/2" SOCKET AND TORQUE WRENCH - OPTIONAL
4MM ALLEN WRENCH

## ASSEMBLY COMPONENTS

ITEMS INCLUDED	PART #	PART DESCRIPTION	QTY
TOP AND APRON ASSEMBLIES	N/A	TOP ASSEMBLY (FACTORY ASSEMBLED)	2
CABINET	N/A	CABINET - SIZE VARIES	1
LEGS	VARIES	LEG,MPL - HEIGHT VARIES	4
LEG HARDWARE	520001-4	LEG HARDWARE KIT, 4 LEGS	1
LEG BRACE	N/A	LEG BRACE - SIZE VARIES	2
STRETCHER	N/A	STRETCHER - SIZE VARIES	2
CONFIRMATS - LEGS	227578	SCREW,7MMX90MM,CONN,ALLENHEAD, BLACK	8
CONFIRMATS - STRETCHER	228564	SCREW,7MMX50MM,CONN,ALLENHEAD, BLACK	8
BOLT - INTERNAL APRON	231922	BOLT, 3/8 -16X1.625 HEX HEAD	4
WASHER - INTERNAL APRON	100451	WASHER,5/16 FLAT ZINC PLATED	4
PENCIL LEDGE	14-0027	PENCIL LEDGE	2
SCREWS - PENCIL LEDGE	236263	SCREW,#6X3/4 TRUSS HEAD,QUAD BLACK	6

**NOTE:**

1.

DWN BY:	EMK	DWN DATE:	1/7/15
APR BY:		DATE APR:	
APR BY:		DATE APR:	

UNLESS OTHERWISE SPECIFIED  
DIMENSION ARE IN INCHES  
CABINET SQUARENESS ± .0625  
FRACTIONAL VALUES ± 1/32"  
- ALL VALUES ± OVERALL -



300 South Krueger Street  
Suring, WI 54174  
diversifiedwoodcrafts.com

TITLE:  
TWO STATION DRAWING TABLE  
TOOLS AND ASSEMBLY COMPONENTS

A	DESCRIPTION	DATE	NAME	ECH NO.
	CREATED ASSEMBLY INSTRUCTIONS	1/7/15	EMK	-
REV.				

THIS DRAWING IS THE SOLE PROPERTY OF  
DIVERSIFIED WOOD CRAFTS. IT MAY NOT  
BE ALTERED OR CHANGED WITHOUT  
PERMISSION

DRAWING NUMBER:	SCALE:	SHEET:	REVISION:
DT-80A, DT-82A, & DTA-21A	NTS	2 OF 10	REV A

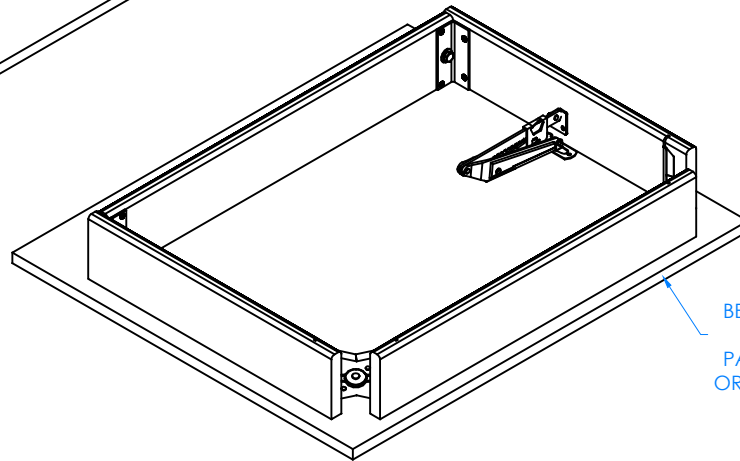
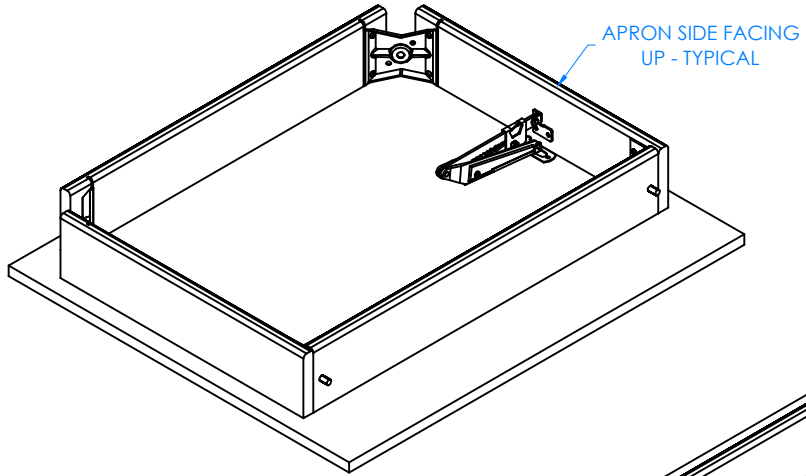

STEP 1:

- LAY THE TWO TOP ASSEMBLIES ON FLOOR WITH APRON SIDE FACING UP.

NOTE:

1.

DWN BY:	EMK	DWN DATE:	1/7/15
APR BY:		DATE APR:	
APR BY:		DATE APR:	

UNLESS OTHERWISE SPECIFIED  
DIMENSION ARE IN INCHES  
CABINET SQUARENESS ± .0625  
FRACTIONAL VALUES ± 1/32"  
- ALL VALUES ± OVERALL -



300 South Krueger Street  
Suring, WI 54174  
diversifiedwoodcrafts.com

TITLE:  
TWO STATION DRAWING TABLE  
ASSEMBLY INSTRUCTIONS

REV.	DESCRIPTION	DATE	NAME	ECH NO.
A	CREATED ASSEMBLY INSTRUCTIONS	1/7/15	EMK	-
REVISION LEVEL				

THIS DRAWING IS THE SOLE PROPERTY OF  
DIVERSIFIED WOOD CRAFTS. IT MAY NOT  
BE ALTERED OR CHANGED WITHOUT  
PERMISSION

DRAWING NUMBER:	SCALE:	SHEET:	REVISION:
DT-80A, DT-82A, & DTA-21A	NTS	3 OF 10	REV A

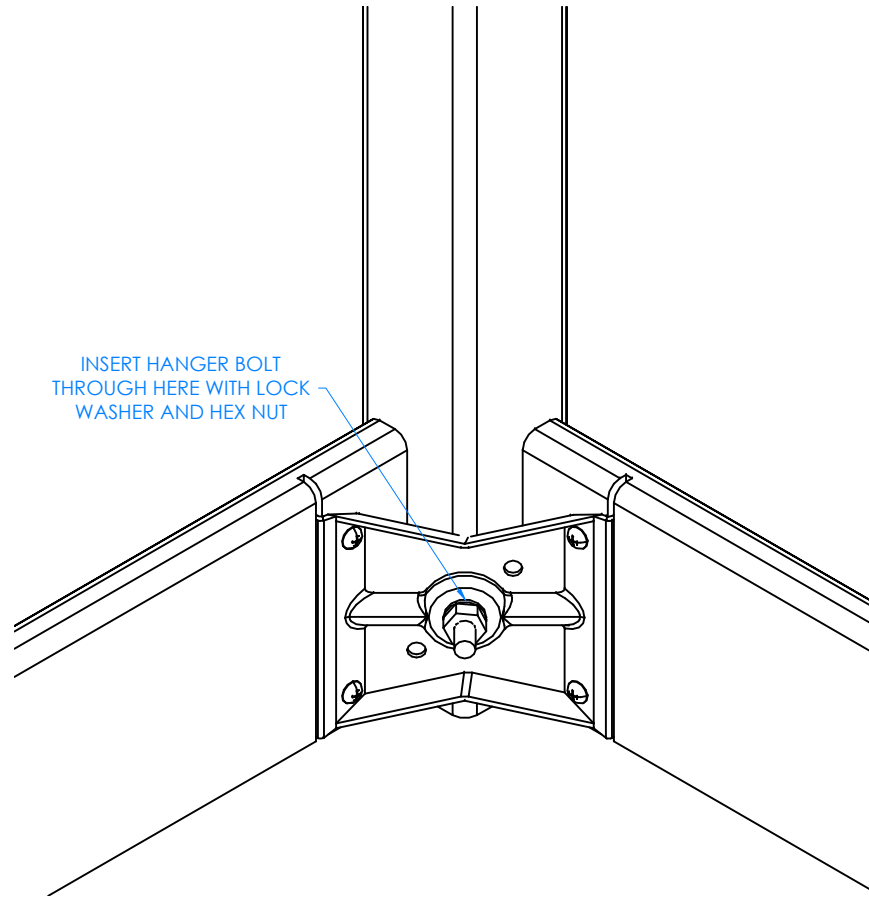

CLOSE UP OF CORNER LEG ASSEMBLY

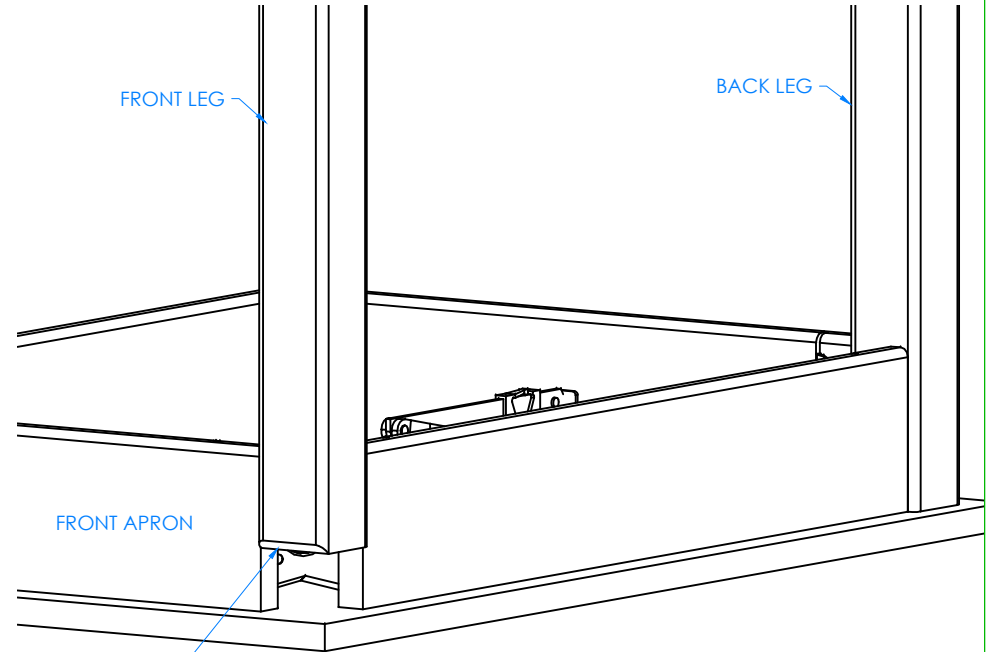

LEG WITH A CHAMFER NEEDS TO BE FACING OUT (BOTH TOP ASSEMBLIES)

CLOSE UP OF LEG WITH A CHAMFER

STEP 2:

- INSERT HANGER BOLT ON ONE LEG THROUGH THE CORNER BRACKET AND INSERT LOCK WASHER AND HEX NUT.
- SCREW ON NUT USING A 1/2" WRENCH OR 1/2" SOCKET AND TORQUE WRENCH.
- DO NOT TIGHTEN ALL THE WAY.
- REPEAT FOR OTHER 3 LEGS.
- THE TWO LEGS WITH A CHAMFER MUST GO ON THE FRONT OF TABLE WITH CHAMFERED EDGES FACING OUT.

NOTE:

- 1.

DWN BY:	EMK	DWN DATE:	1/7/15
APR BY:		DATE APR:	
APR BY:		DATE APR:	

UNLESS OTHERWISE SPECIFIED  
DIMENSION ARE IN INCHES  
CABINET SQUARENESS ± .0625  
FRACTIONAL VALUES ± 1/32"  
- ALL VALUES ± OVERALL -



300 South Krueger Street  
Suring, WI 54174  
diversifiedwoodcrafts.com

TITLE:  
TWO STATION DRAWING TABLE  
ASSEMBLY INSTRUCTIONS

REV.	DESCRIPTION	DATE	NAME	ECH NO.
A	CREATED ASSEMBLY INSTRUCTIONS	1/7/15	EMK	-
REVISION LEVEL				

THIS DRAWING IS THE SOLE PROPERTY OF  
DIVERSIFIED WOOD CRAFTS. IT MAY NOT  
BE ALTERED OR CHANGED WITHOUT  
PERMISSION

DRAWING NUMBER:	SCALE:	SHEET:	REVISION:
DT-80A, DT-82A, & DTA-21A	NTS	4 OF 10	REV A

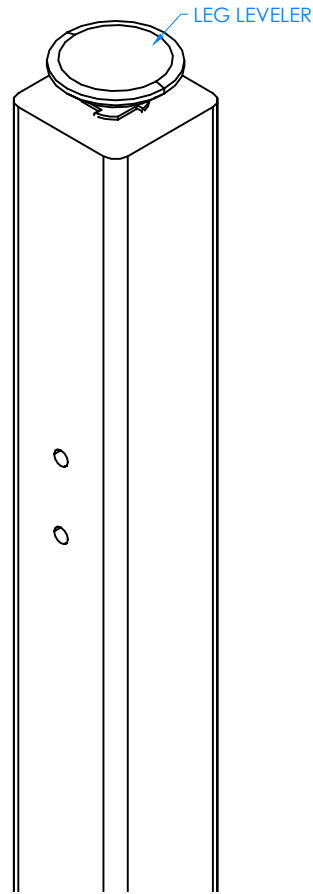

CLOSE UP OF LEG LEVELER ASSEMBLY

STEP 3:

- SCREW LEG LEVELERS INTO T-NUT ON BOTTOM OF LEGS.

NOTE:

1.

DWN BY:	EMK	DWN DATE:	1/7/15
APR BY:		DATE APR:	
APR BY:		DATE APR:	

UNLESS OTHERWISE SPECIFIED  
DIMENSION ARE IN INCHES  
CABINET SQUARENESS ± .0625  
FRACTIONAL VALUES ± 1/32"  
- ALL VALUES ± OVERALL -



300 South Krueger Street  
Suring, WI 54174  
diversifiedwoodcrafts.com

TITLE:  
TWO STATION DRAWING TABLE  
ASSEMBLY INSTRUCTIONS

REV.	DESCRIPTION	DATE	NAME	ECH NO.
A	CREATED ASSEMBLY INSTRUCTIONS	1/7/15	EMK	-

REVISION LEVEL

THIS DRAWING IS THE SOLE PROPERTY OF  
DIVERSIFIED WOOD CRAFTS. IT MAY NOT  
BE ALTERED OR CHANGED WITHOUT  
PERMISSION

DRAWING NUMBER:	SCALE:	SHEET:	REVISION:
DT-80A, DT-82A, & DTA-21A	NTS	5 OF 10	REV A

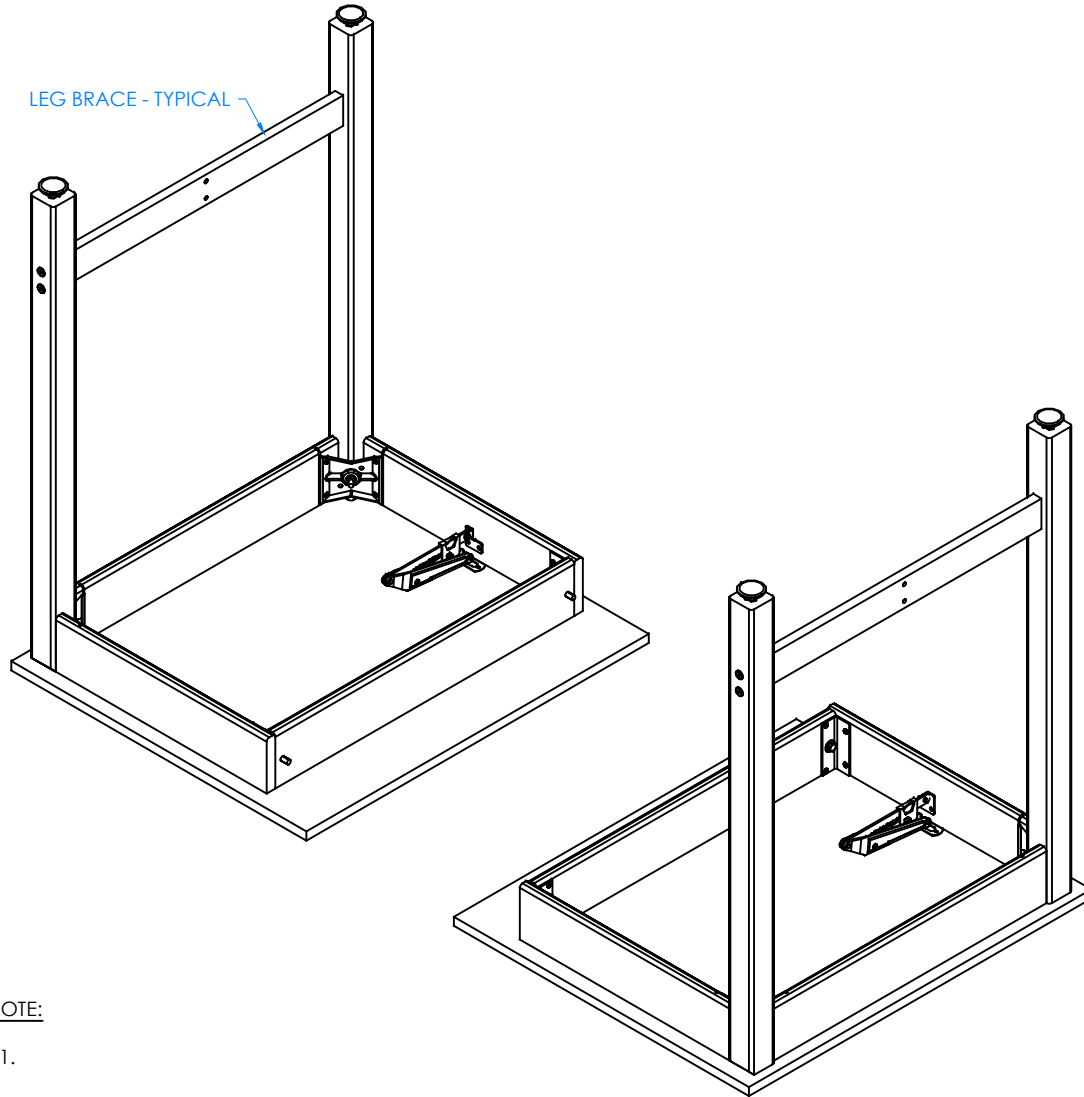

STEP 4:

- ATTCH BRACES TO LEGS.
- INSERT CONFIRMATS INTO ONE LEG AND SCREW INTO BRACE.
- REPEAT FOR THE OTHER LEG.
- MAKE SURE BRACES ARE STRAIGHT AND CONFIRMATS ARE TIGHT.

NOTE:

- 1.

DWN BY:	EMK	DWN DATE:	1/7/15
APR BY:		DATE APR:	
APR BY:		DATE APR:	

UNLESS OTHERWISE SPECIFIED  
DIMENSION ARE IN INCHES  
CABINET SQUARENESS ± .0625  
FRACTIONAL VALUES ± 1/32"  
- ALL VALUES ± OVERALL -



300 South Krueger Street  
Suring, WI 54174  
diversifiedwoodcrafts.com

TITLE:  
TWO STATION DRAWING TABLE  
ASSEMBLY INSTRUCTIONS

REV.	DESCRIPTION	DATE	NAME	ECH NO.
A	CREATED ASSEMBLY INSTRUCTIONS	1/7/15	EMK	-
REVISION LEVEL				

THIS DRAWING IS THE SOLE PROPERTY OF  
DIVERSIFIED WOOD CRAFTS. IT MAY NOT  
BE ALTERED OR CHANGED WITHOUT  
PERMISSION

DRAWING NUMBER:	SCALE:	SHEET:	REVISION:
DT-80A, DT-82A, & DTA-21A	NTS	6 OF 10	REV A

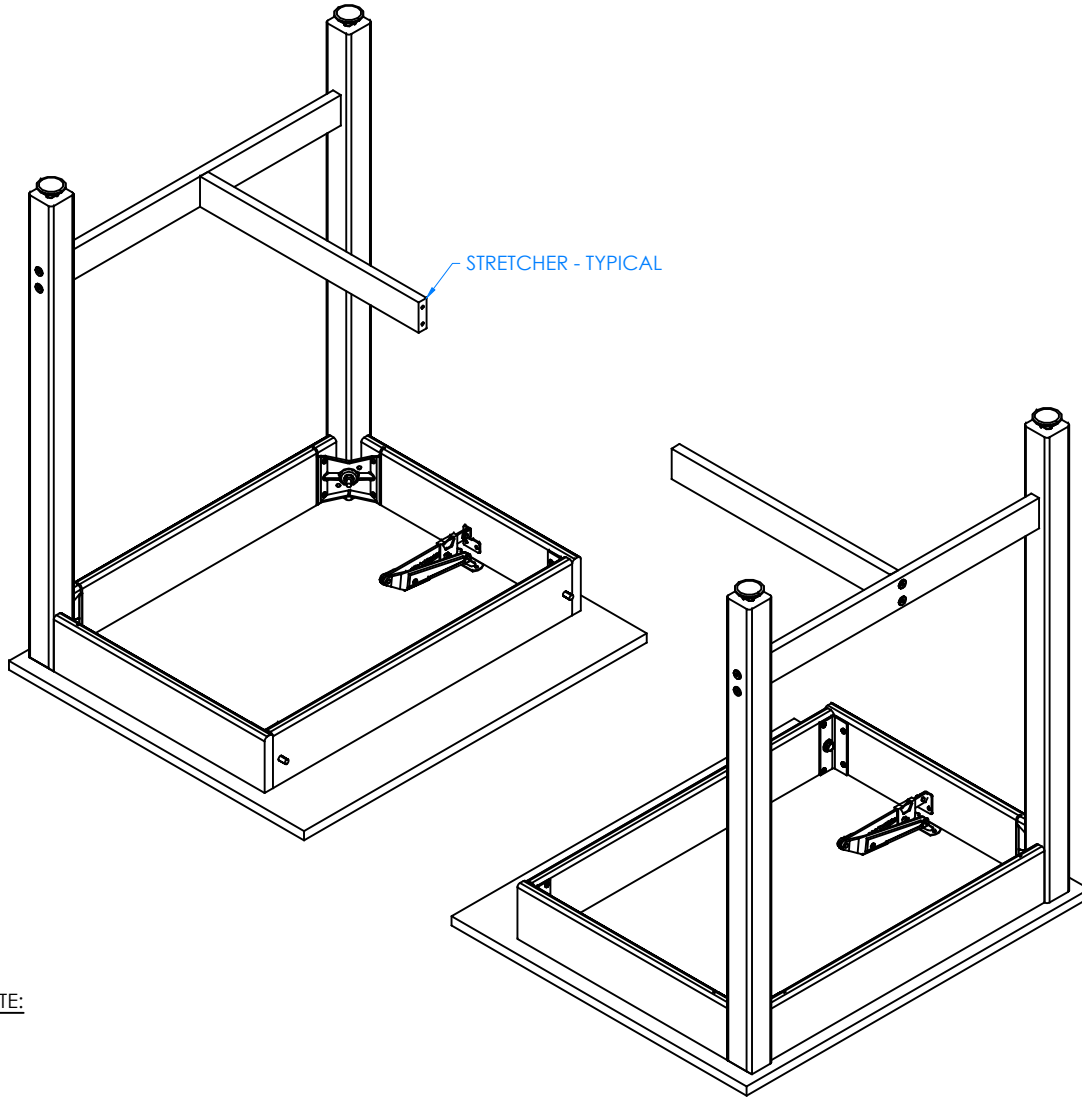

NOTE:

1.

STEP 5:

- ATTACH STRETCHERS TO THE BRACES USING HARDWARE PROVIDED.
- GO BACK TO STEP 2 AND TIGHTEN UP THE HANGER BOLTS FOR EACH LEG USING A 1/2" WRENCH OR 1/2" SOCKET AND TORQUE WRENCH, TO A MINIMUM OF 12FT LBS BUT NOT TO EXCEED 17FT LBS.

DWN BY:	EMK	DWN DATE:	1/7/15
APR BY:		DATE APR:	
BY:		DATE APR:	

UNLESS OTHERWISE SPECIFIED  
DIMENSION ARE IN INCHES  
CABINET SQUARENESS ± .0625  
FRACTIONAL VALUES ± 1/32"  
- ALL VALUES ± OVERALL -



300 South Krueger Street  
Suring, WI 54174  
diversifiedwoodcrafts.com

TITLE:  
TWO STATION DRAWING TABLE  
ASSEMBLY INSTRUCTIONS

REV.	DESCRIPTION	DATE	NAME	ECH NO.
A	CREATED ASSEMBLY INSTRUCTIONS	1/7/15	EMK	-
REVISION LEVEL				

THIS DRAWING IS THE SOLE PROPERTY OF  
DIVERSIFIED WOOD CRAFTS. IT MAY NOT  
BE ALTERED OR CHANGED WITHOUT  
PERMISSION

DRAWING NUMBER:	SCALE:	SHEET:	REVISION:
DT-80A, DT-82A, & DTA-21A	NTS	7 OF 10	REV A

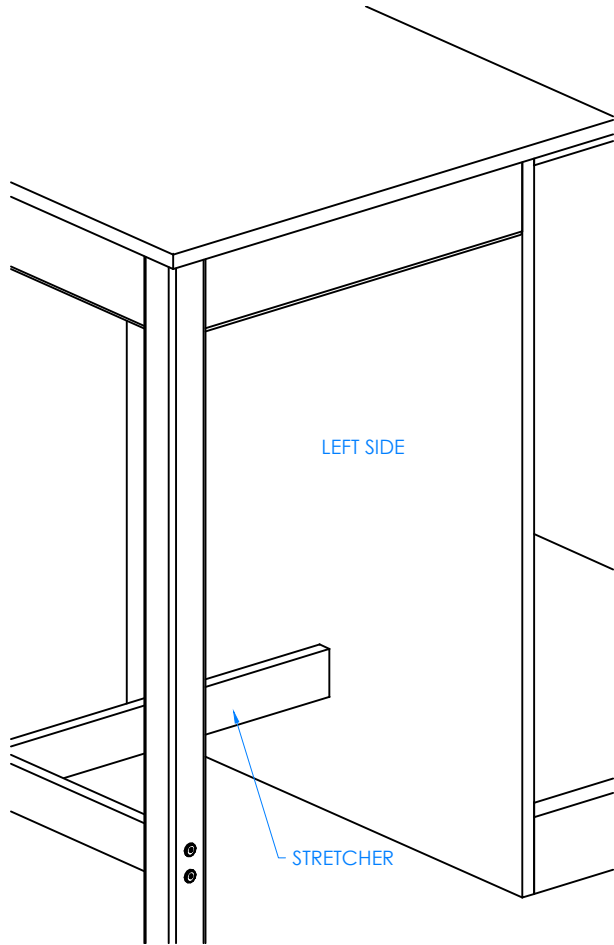

OUTSIDE OF CABINET

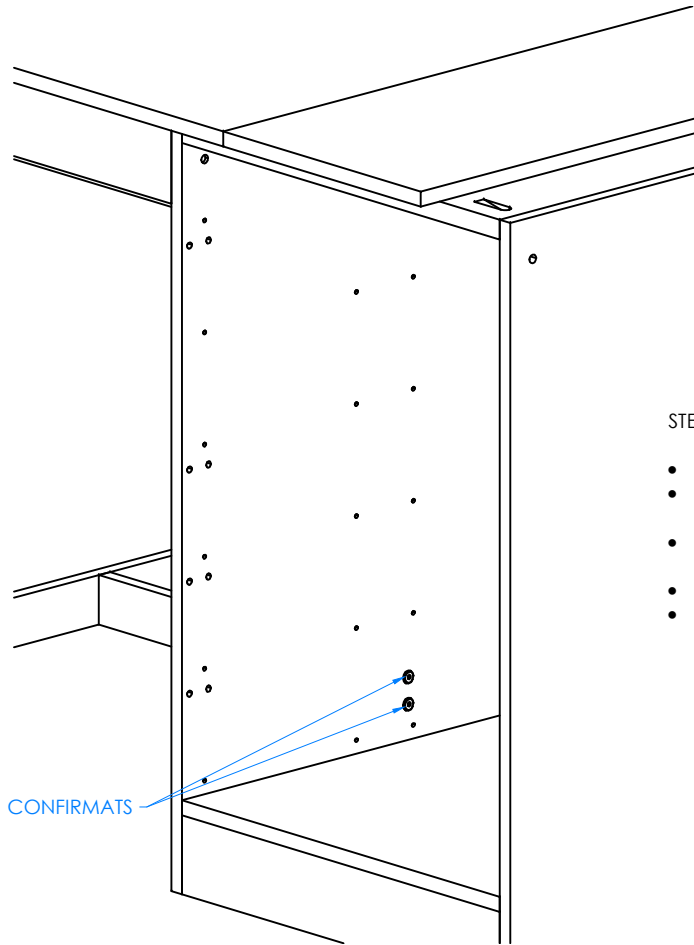

INSIDE OF CABINET

STEP 6:

- FLIP ONE APRON ASSEMBLY OVER ONTO LEGS.
- ALIGN HOLES UP ON STRETCHER TO HOLES ON LEFT SIDE OF CABINET.
- TAKE OUT DRAWERS TO ATTACH STRETCHER FROM INSIDE THE CABINET.
- ATTACH TO CABINET WITH HARDWARE PROVIDED.
- REPEAT PROCESS FOR OTHER APRON ASSEMBLY.

NOTE:

1.

DRAWERS AND HARDWARE REMOVED FOR CLARITY

DWN BY:	EMK	DWN DATE:	1/7/15
APR BY:		DATE APR:	
APR BY:		DATE APR:	

UNLESS OTHERWISE SPECIFIED  
DIMENSION ARE IN INCHES  
CABINET SQUARENESS ± .0625  
FRACTIONAL VALUES ± 1/32"  
- ALL VALUES ± OVERALL -



300 South Krueger Street  
Suring, WI 54174  
diversifiedwoodcrafts.com

TITLE:  
TWO STATION DRAWING TABLE  
ASSEMBLY INSTRUCTIONS

REV.	DESCRIPTION	DATE	NAME	ECH NO.
A	CREATED ASSEMBLY INSTRUCTIONS	1/7/15	EMK	-
REVISION LEVEL				

THIS DRAWING IS THE SOLE PROPERTY OF  
DIVERSIFIED WOOD CRAFTS. IT MAY NOT  
BE ALTERED OR CHANGED WITHOUT  
PERMISSION

DRAWING NUMBER:	SCALE:	SHEET:	REVISION:
DT-80A, DT-82A, & DTA-21A	NTS	8 OF 10	REV A

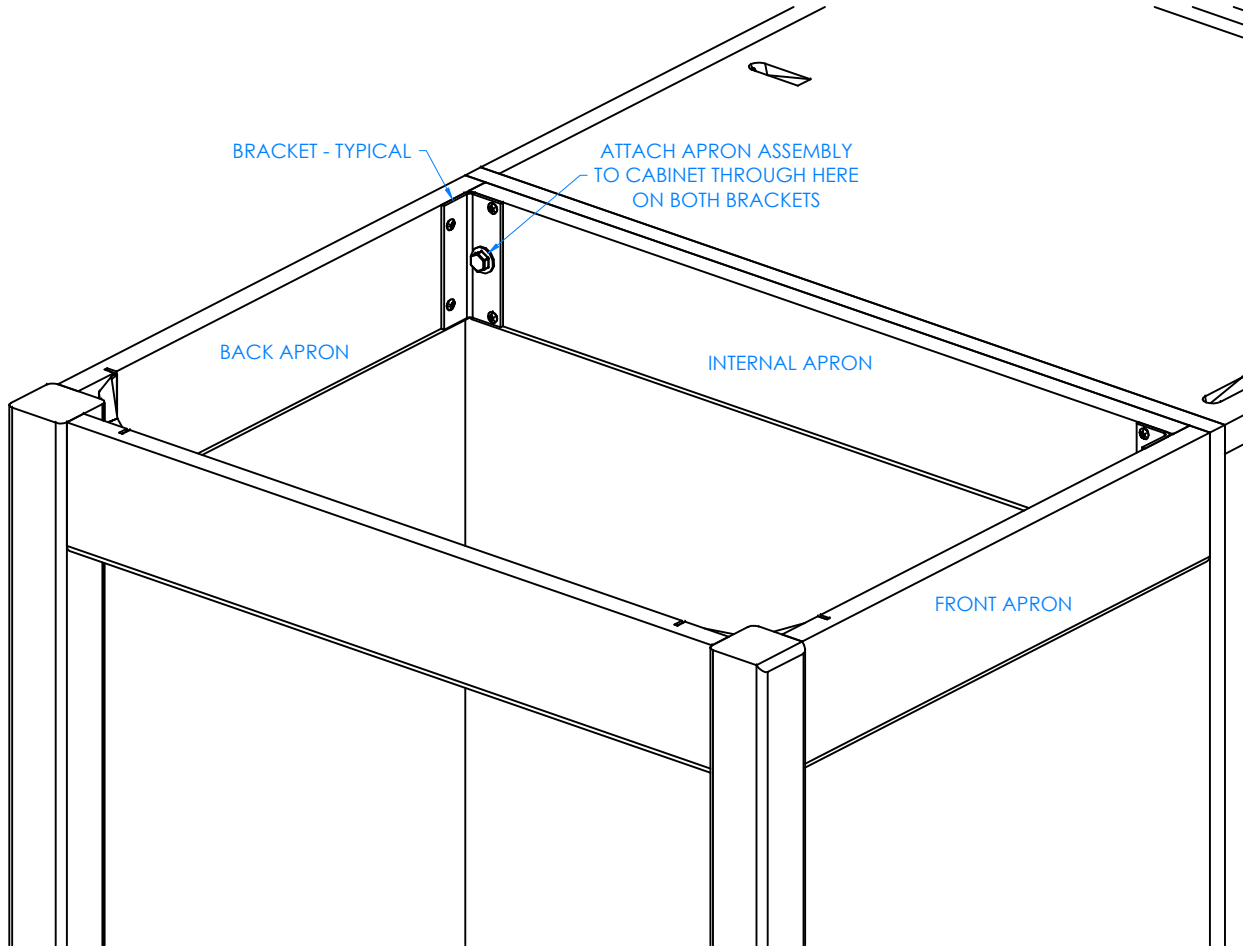

STEP 7:

- POSITION ONE APRON ASSEMBLY SO INNER HOLES OF BRACKETS ON INTERNAL APRON ARE LINED UP WITH THE TWO HOLES ON LEFT SIDE OF CABINET.
- FRONT APRON WILL BE FLUSH WITH FRONT OF CABINET AND BACK APRON WILL BE FLUSH WITH BACK OF CABINET.
- ATTACH APRON ASSEMBLY TO LEFT SIDE OF CABINET WITH HARDWARE PROVIDED.
- ADJUST LEG LEVELERS TO LEVEL APRON ASSEMBLY WITH CABINET.

CLOSE UP OF APRON ASSEMBLY SHOWN (TOPS REMOVED FOR CLARITY)

NOTE:

- 1.

DWN BY:	EMK	DWN DATE:	1/7/15
APR BY:		DATE APR:	
APR BY:		DATE APR:	

UNLESS OTHERWISE SPECIFIED DIMENSION ARE IN INCHES  
 CABINET SQUARENESS ± .0625  
 FRACTIONAL VALUES ± 1/32"  
 - ALL VALUES ± OVERALL -



300 South Krueger Street  
 Suring, WI 54174  
 diversifiedwoodcrafts.com

TITLE:  
 TWO STATION DRAWING TABLE  
 ASSEMBLY INSTRUCTIONS

REV.	DESCRIPTION	DATE	NAME	ECH NO.
A	CREATED ASSEMBLY INSTRUCTIONS	1/7/15	EMK	-
REVISION LEVEL				

THIS DRAWING IS THE SOLE PROPERTY OF DIVERSIFIED WOOD CRAFTS. IT MAY NOT BE ALTERED OR CHANGED WITHOUT PERMISSION

DRAWING NUMBER:	SCALE:	SHEET:	REVISION:
DT-80A, DT-82A, & DTA-21A	NTS	9 OF 10	REV A

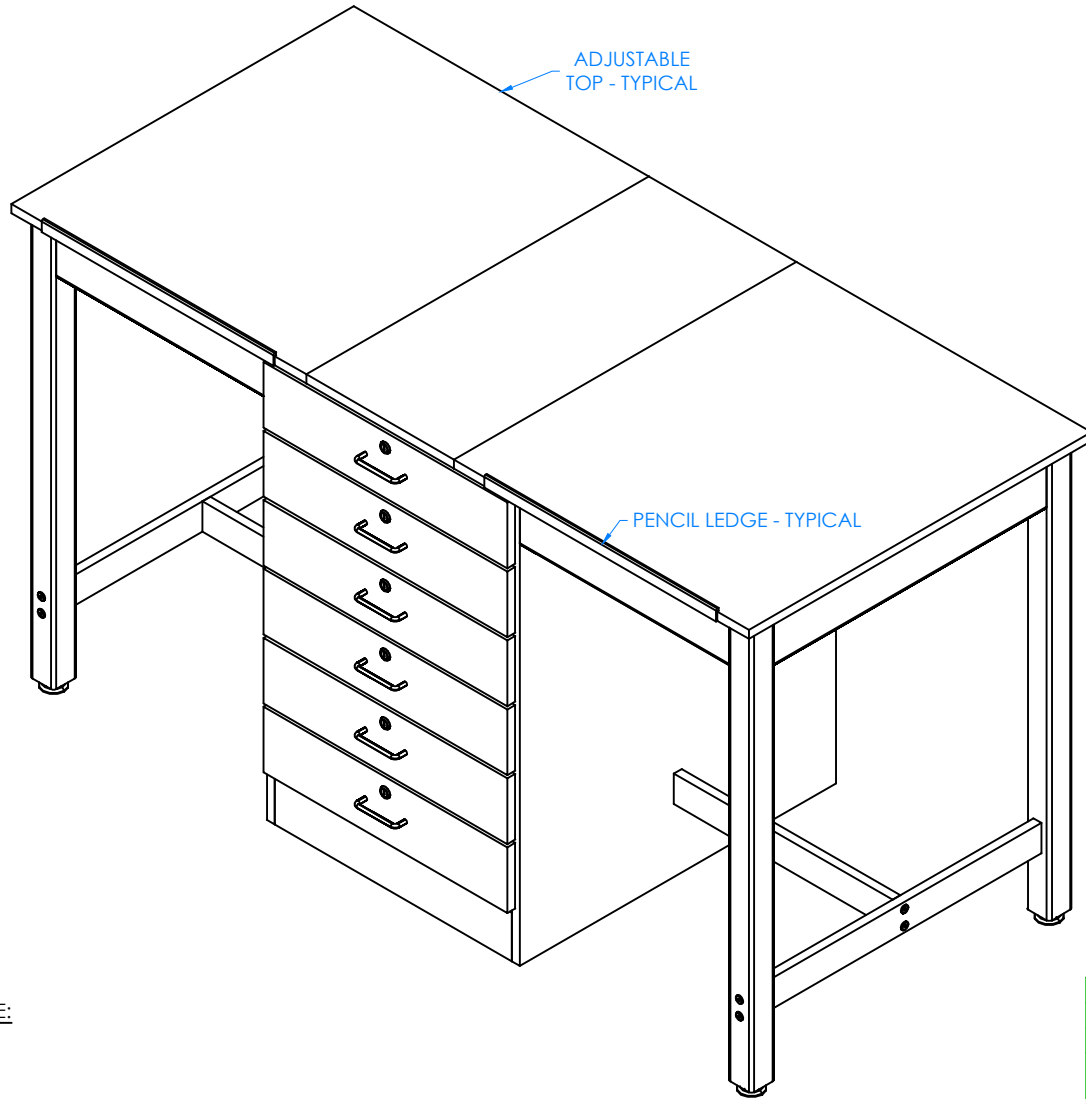

STEP 8:

- LINE UP PENCIL LEDGE ON SIDE OF ADJUSTABLE TOPS IN DESIRED LOCATION.
- PRE-DRILL HOLES IN TOP TO PREVENT SPLITTING.
- SCREW PENCIL LEDGE TO TOP USING HARDWARE PROVIDED.
- SET YOUR TABLE IN PLACE.
- PUT DRAWERS BACK IN.

NOTE:

1.

COMPLETE UNIT SHOWN

DWN BY:	EMK	DWN DATE:	1/7/15
APR BY:		DATE APR:	
APR BY:		DATE APR:	

UNLESS OTHERWISE SPECIFIED  
DIMENSION ARE IN INCHES  
CABINET SQUARENESS ± .0625  
FRACTIONAL VALUES ± 1/32"  
- ALL VALUES ± OVERALL -



300 South Krueger Street  
Suring, WI 54174  
diversifiedwoodcrafts.com

TITLE:  
TWO STATION DRAWING TABLE  
ASSEMBLY INSTRUCTIONS

REV.	DESCRIPTION	DATE	NAME	ECH NO.
A	CREATED ASSEMBLY INSTRUCTIONS	1/7/15	EMK	-
REVISION LEVEL				

THIS DRAWING IS THE SOLE PROPERTY OF  
DIVERSIFIED WOOD CRAFTS. IT MAY NOT  
BE ALTERED OR CHANGED WITHOUT  
PERMISSION

DRAWING NUMBER:	SCALE:	SHEET:	REVISION:
DT-80A, DT-82A, & DTA-21A	NTS	10 OF 10	REV A