





ASSEMBLY INSTRUCTIONS







DESCRIPTION: FULL BED

Thanks you for purchasing this quality product.

Please read intructions carefully prior to assembly.

Check carefully for small parts which may have come loose during transportation inside all the boxes. Remove from boxes and place all parts and components on soft surface such as carpet, blanket or furniture pad. Identify and verify all parts and hardware as specified below.

(BOX 1) BOX 1 OF HEADBOARD&FOOTBOARD			
NO	DESCRIPTION	OUTLOOK	QT.
1	HEADBOARD		1
2	K/D LEG (L/R)		2
3	FOOTBOARD		1
4	SLATS		4
5	SUPPORT LEG		4

(BOX 2) BOX 2 OF SIDE RAIL			
NO	DESCRIPTION	OUTLOOK	QT.
6	SIDE RAIL (R/L)		2
(BOX 1) HARDWARE LIST			
A		Ø5/16"x1- 3/4"L	6
B		Ø5/16"	6
C		Ø5/16"	6
D		5MM	1
E		#8x1- 1/4"L	8

Tools Required (not provided)

DESCRIPTION	OUTLOOK
PHILLIPS SCREWDRIVER	

Assembly Tips:

- Do not tighten screws and bolts until final steps of the assembly
- This assembly may require additional help (2 person set up)

ASSEMBLY INSTRUCTIONS

DESCRIPTION: FULL BED

STEP 1

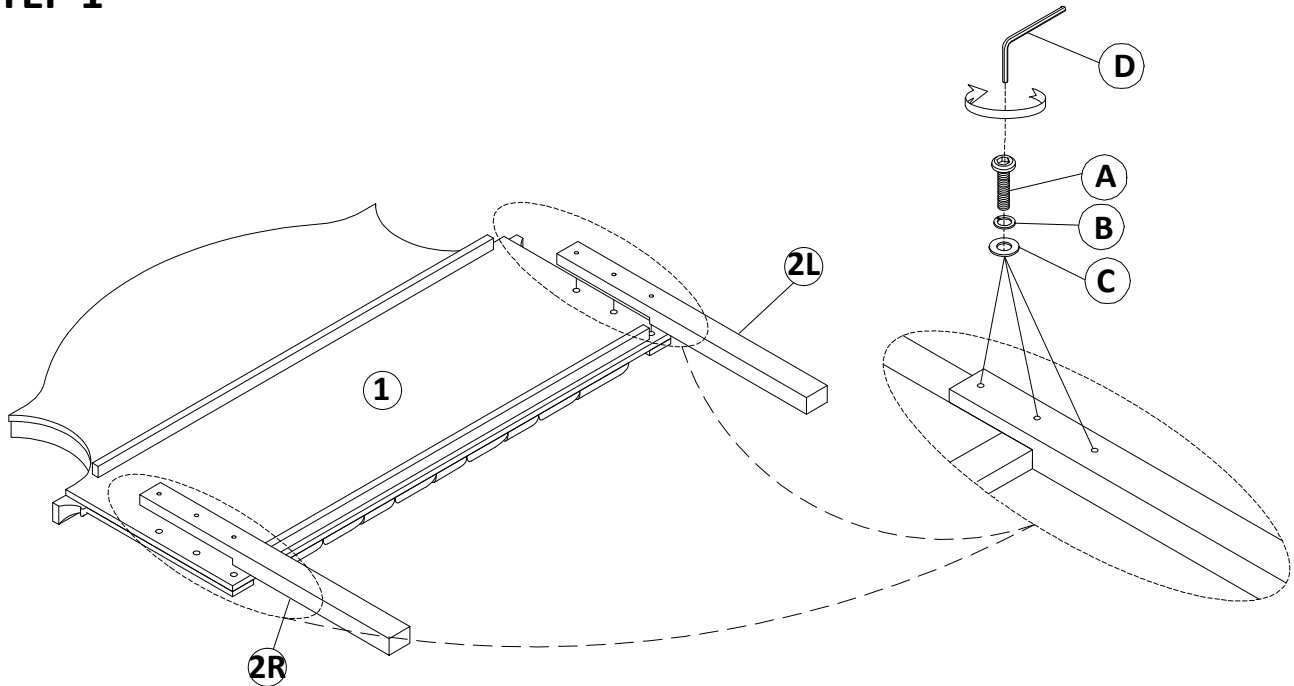

STEP 2

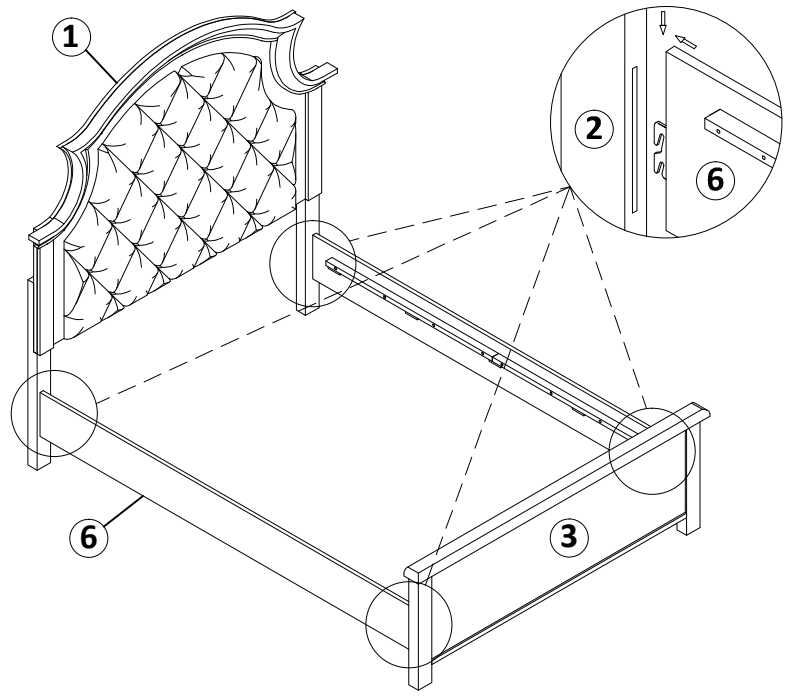

Tools Required (not provided)

DESCRIPTION	OUTLOOK
PHILLIPS SCREWDRIVER	

Assembly Tips:

- Do not tighten screws and bolts until final steps of the assembly
- This assembly may require additional help (2 person set up)

ASSEMBLY INSTRUCTIONS

DESCRIPTION: FULL BED

STEP 3

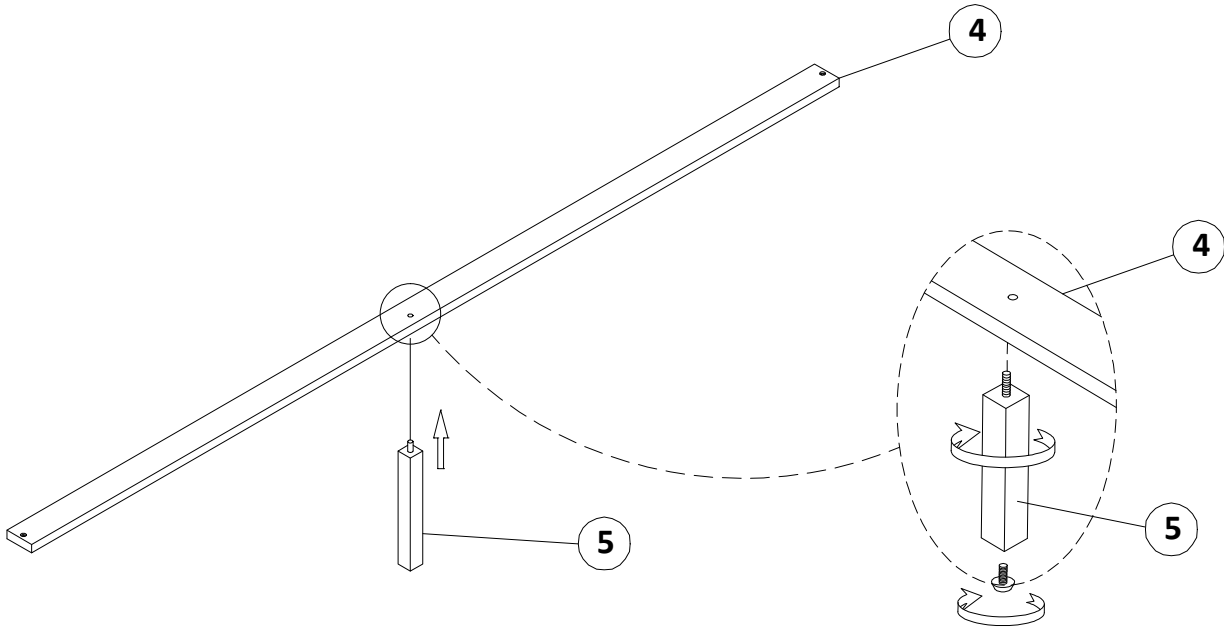

STEP 4

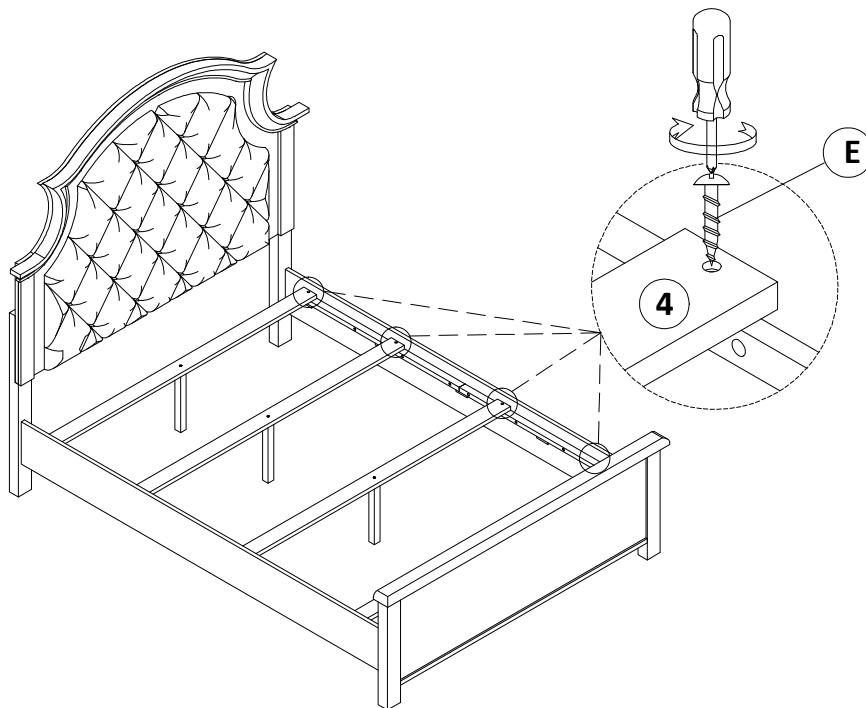

Tools Required (not provided)

DESCRIPTION	OUTLOOK
PHILLIPS SCREWDRIVER	

Assembly Tips:

- Do not tighten screws and bolts until final steps of the assembly
- This assembly may require additional help (2 person set up)

ASSEMBLY INSTRUCTIONS

DESCRIPTION: FULL BED

STEP 5

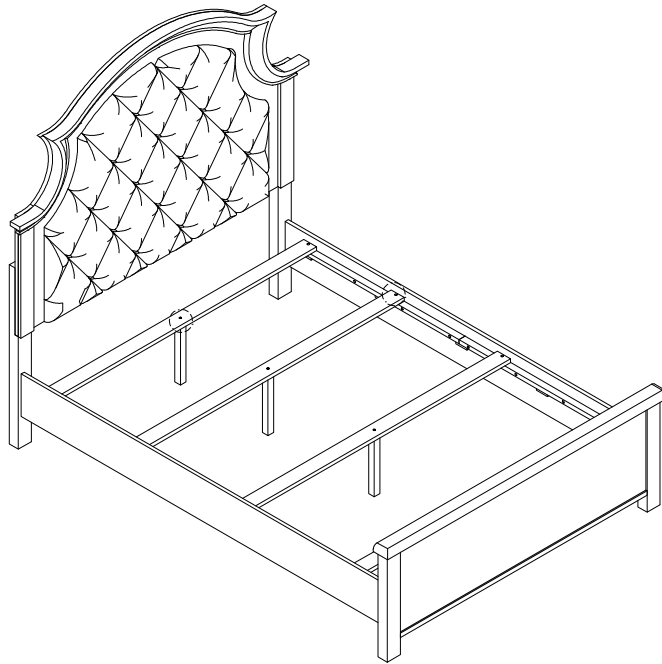

Completed

Tools Required (not provided)

DESCRIPTION	OUTLOOK
PHILLIPS SCREWDRIVER	



Assembly Tips:

- Do not tighten screws and bolts until final steps of the assembly
- This assembly may require additional help (2 person set up)