

# Installation & Assembly

Version:1.0

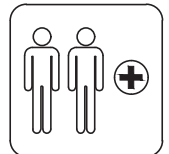
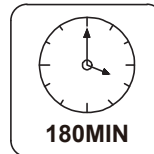
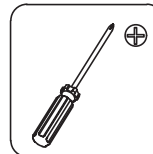
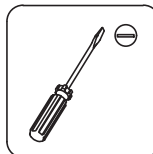
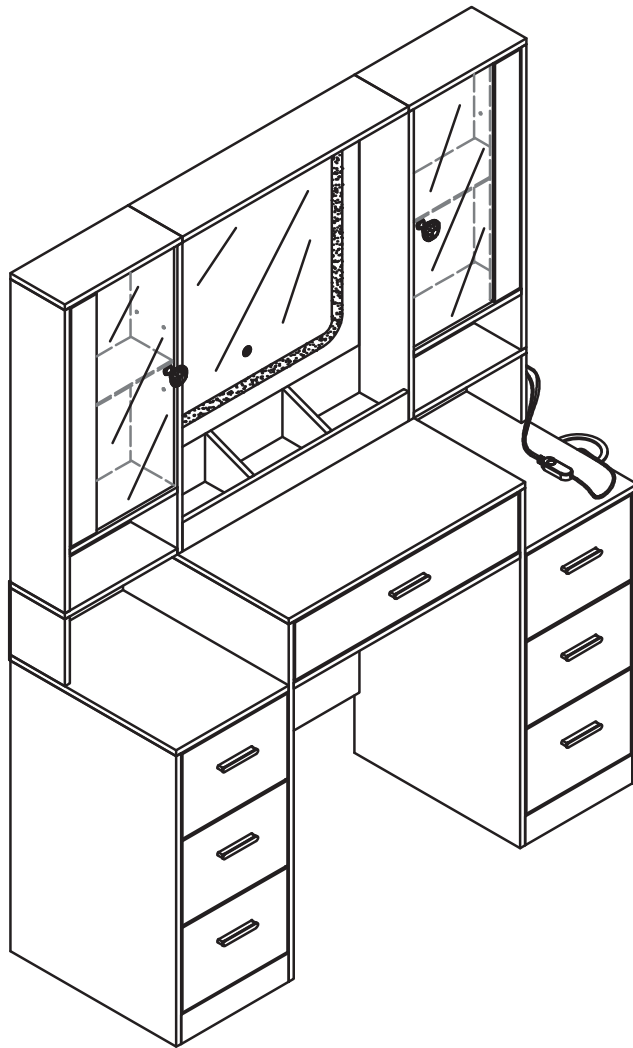

**EN\_IMPORTANT, RETAIN FOR FUTURE REFERENCE: READ CAREFULLY.**

## USING CAM LOCK AND QUICKFIT

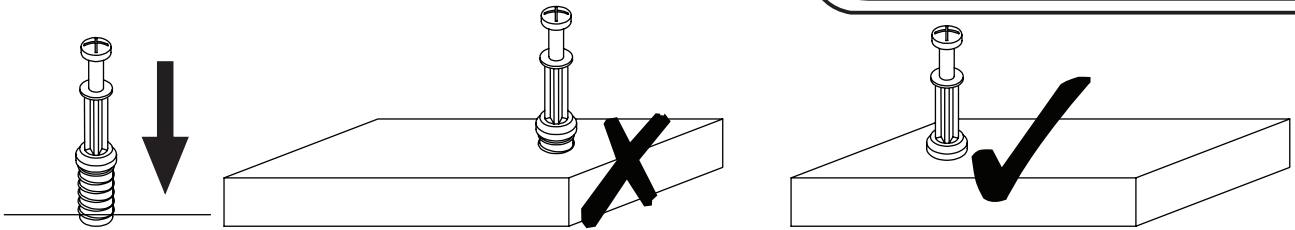

**EN\_QUICKFIT:** Tighten quickfit until shoulder is flush with panel. Do not overtighten or undertighten.

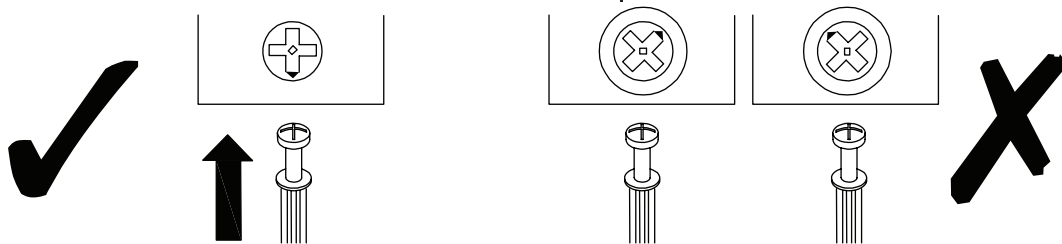

**EN\_CAM LOCK:** When fitting cam lock, ensure starting position is correct before you insert connecting quickfit.

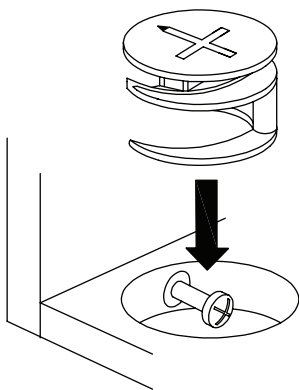



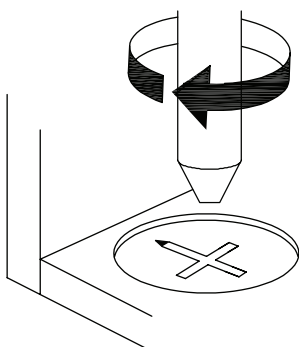





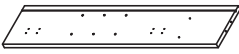
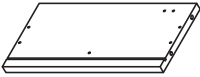

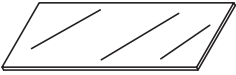
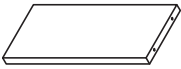
**EN\_Quickfit** head should be in the centre of the cam lock when the two panels are joined.  
Cam lock should be inserted before quickfit.

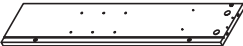

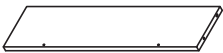
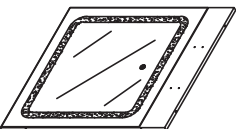

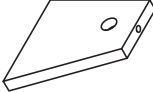
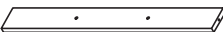
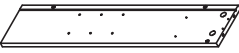

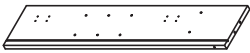
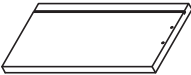
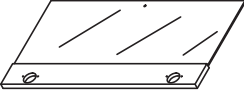
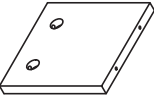

**EN\_Turn** cam lock clockwise to tighten.



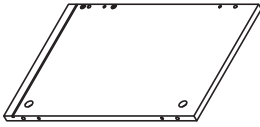

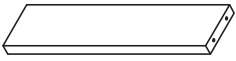

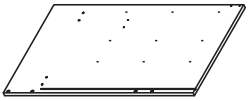
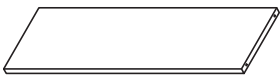
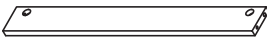
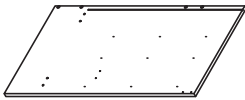
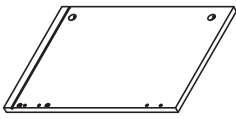

**PACKING DETAILS**

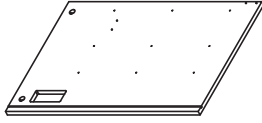
NO.	PARTS	QTY	SPARE
①		x1	
②		x1	
③		x2	
④		x2	
⑤		x2	
⑥		x1	
⑦		x1	
⑧		x2	
⑨		x1	
⑩		x1	

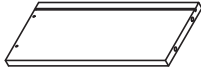

NO.	PARTS	QTY	SPARE
⑪		x2	
⑫		x1	
⑬		x1	
⑭		x1	
⑮		x1	
⑯		x1	
⑰		x2	
⑱		x2	
⑳		x1	
㉑		x1	

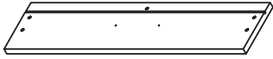
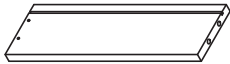
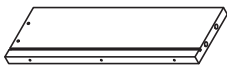
PACKING DETAILS

NO.	PARTS	QTY	SPARE
22		x1	
23		x1	
24		x4	
25		x2	
26		x1	
27		x2	
28		x1	
30		x1	
31		x1	
32		x1	

NO.	PARTS	QTY	SPARE
33		x1	
39		x6	
40		x6	
41		x6	
42		x6	
43		x6	
44		x1	
45		x1	
46		x1	
47		x1	

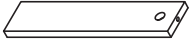
**PACKING DETAILS**

NO.	PARTS	QTY	SPARE
④8		x1	
④9		x1	
	 <p data-bbox="293 770 485 801">Hardware Kit</p>	x1	

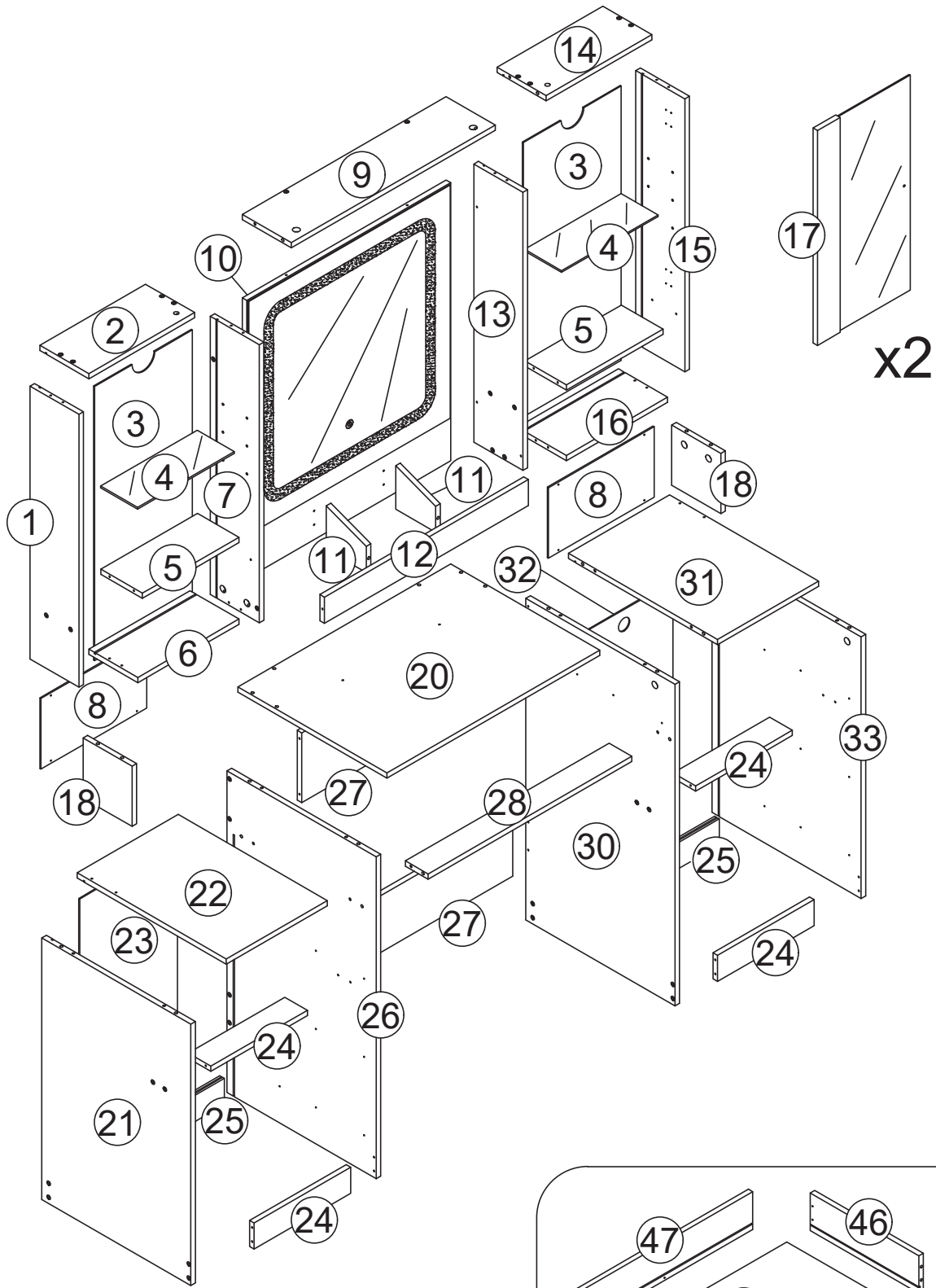



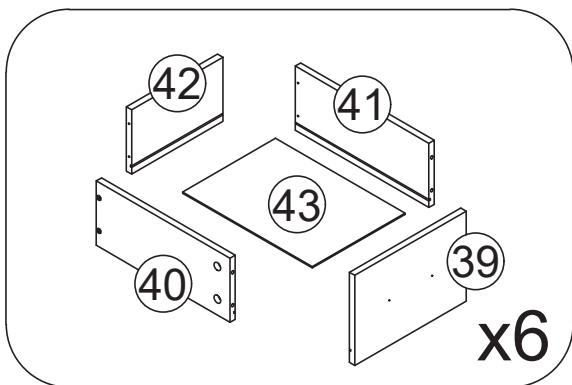



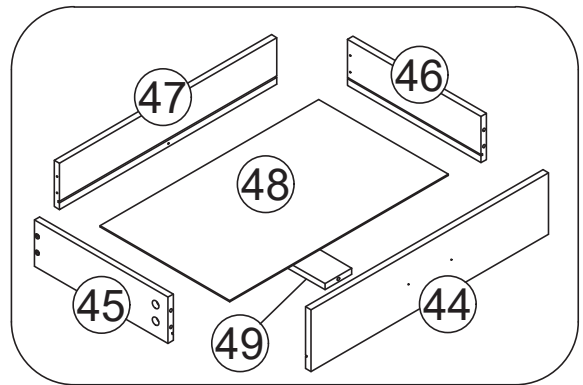

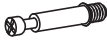



















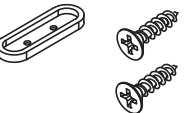

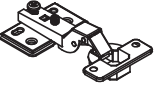
x2



x6



<p><b>A</b> x55 Ø6x35mm +3(spare)</p> 	<p><b>B</b> x57 Ø15x10mm +3(spare)</p> 	<p><b>C</b> x16 Ø6x30mm +2(spare)</p> 	<p><b>D</b> x105 Ø4x35mm +4(spare)</p> 	<p><b>E</b> x84 +4(spare)</p> 	<p><b>F</b> x7 Ø4x16mm</p> 
<p><b>G</b> x2 Ø4x12mm</p> 	<p><b>H</b> x6</p> 	<p><b>I</b> x2</p> 	<p><b>J</b> x1</p> 	<p><b>K</b> x2 Ø3.5x12mm</p> 	<p><b>L</b> x1</p> 
<p><b>M</b> x2 Ø6x30mm</p> 	<p><b>N</b> x2 Ø4x14mm</p> 	<p><b>O</b> x2</p> 	<p><b>P</b> x2 Ø6x55mm</p> 	<p><b>Q</b> x1</p> 	<p><b>R</b> x2 Ø3x10mm</p> 
<p><b>S</b> x2</p> 	<p><b>T</b> x1</p> 	<p><b>U</b> x1</p> 	<p><b>V</b> x2</p> 	<p><b>W</b> x8</p> 	<p><b>X</b> x8</p> 
<p><b>Y</b> x4</p> 	<p><b>AA</b> x24 Ø3.5x12mm +2(spare)</p> 	<p><b>BB</b> x66 +4(spare)</p> 	<p><b>CC</b> x16 Ø3x16mm +2(spare)</p> 	<p><b>DD</b> x1</p> 	
<p><b>CL</b> x7 L300mm</p> 	<p><b>CR</b> x7 L300mm</p> 	<p><b>DL</b> x7 L300mm</p> 	<p><b>DR</b> x7 L300mm</p> 		

E x9

CL x3

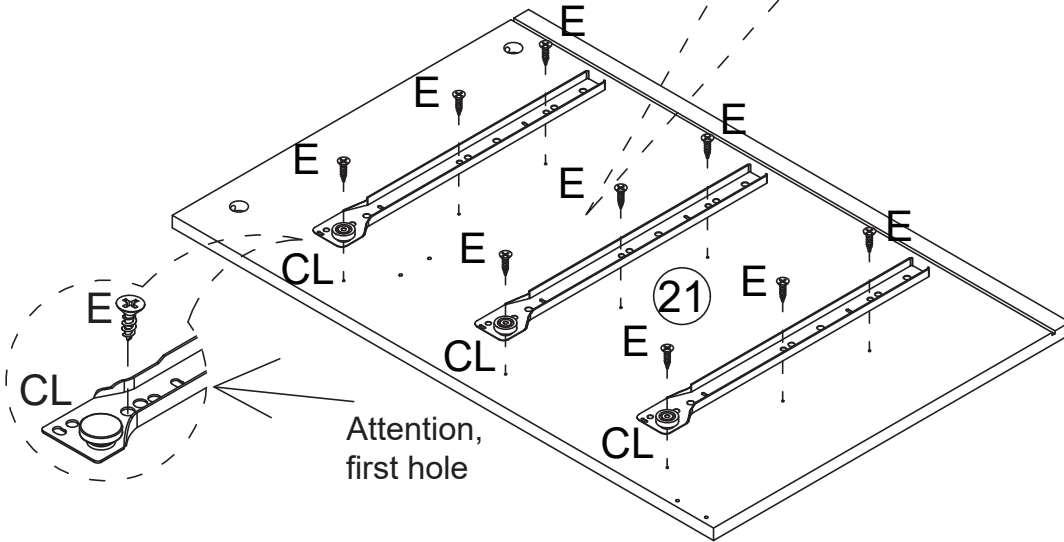
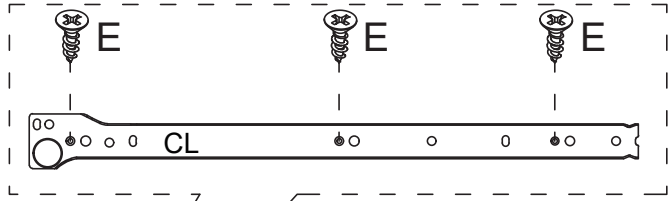

Attention, first hole

E x9

CR x3

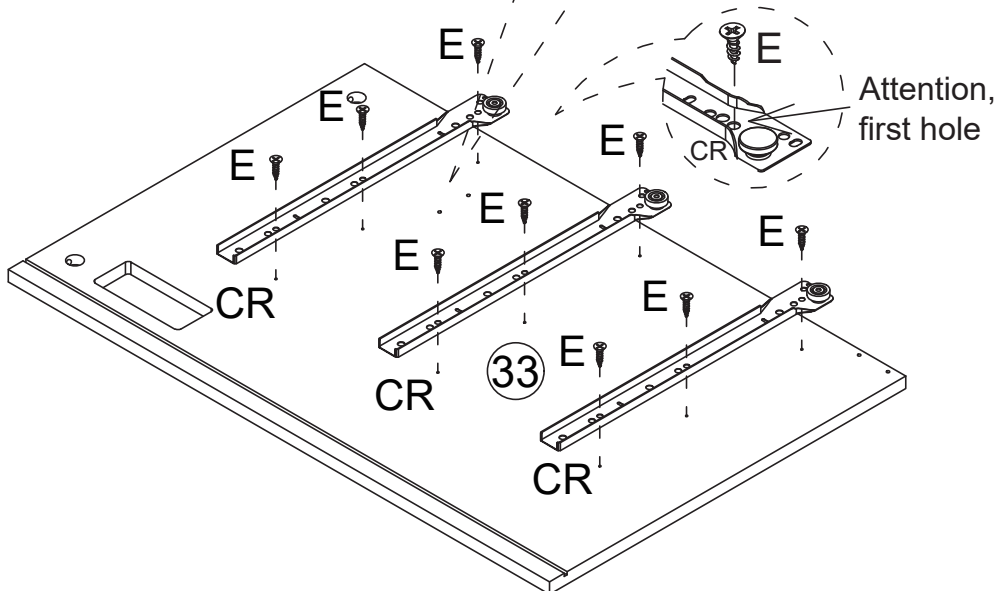
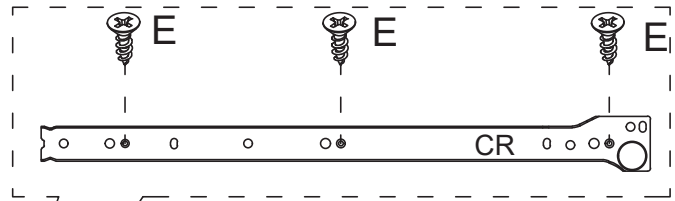

Attention, first hole

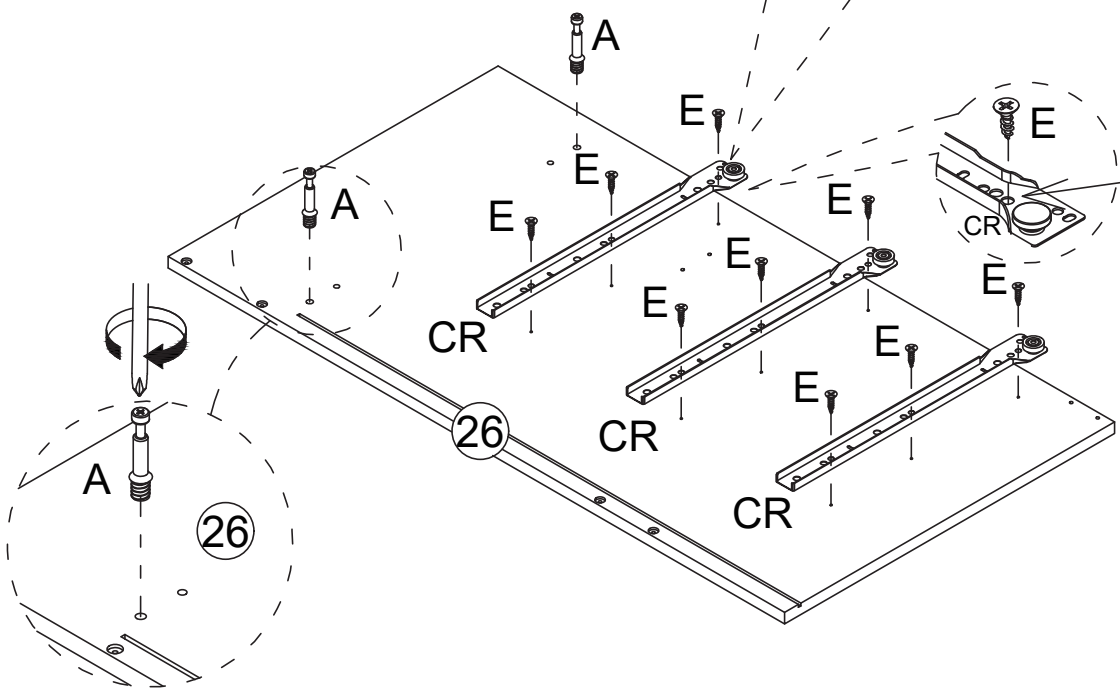
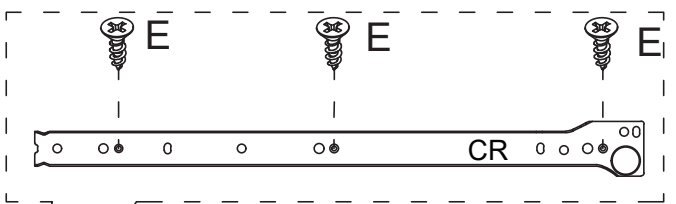
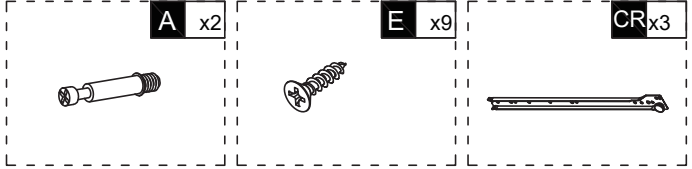

Attention,  
first hole

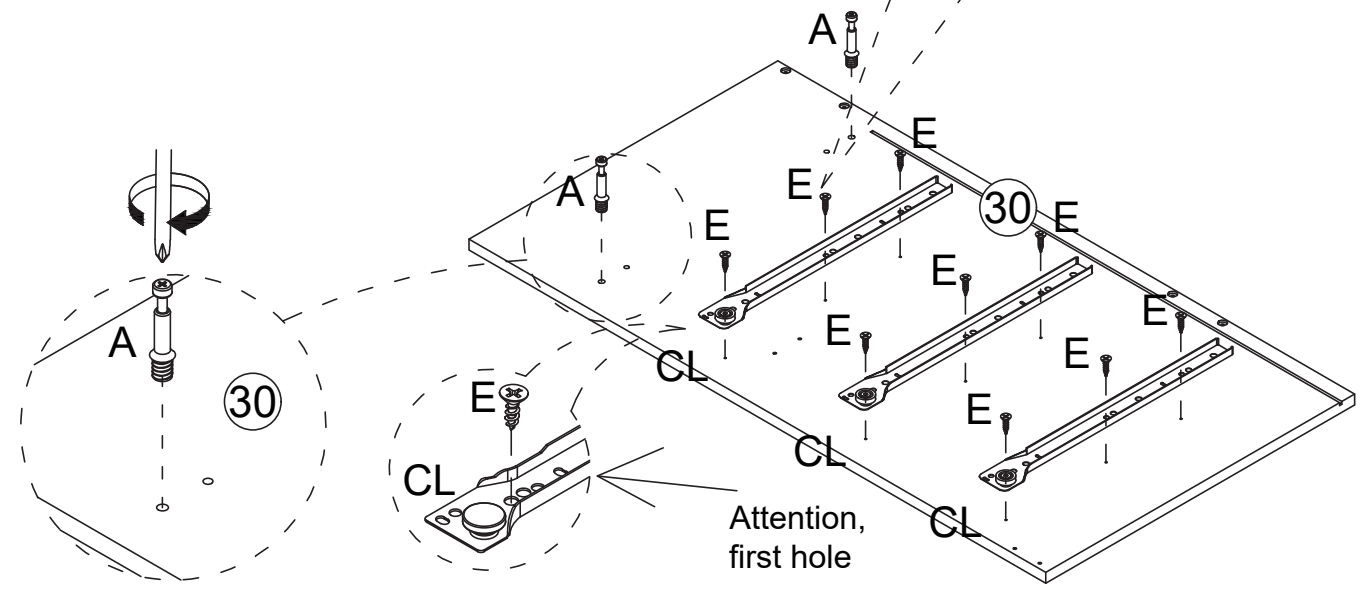
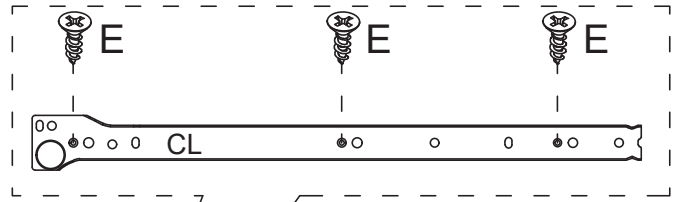
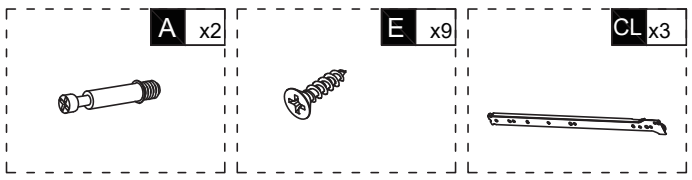
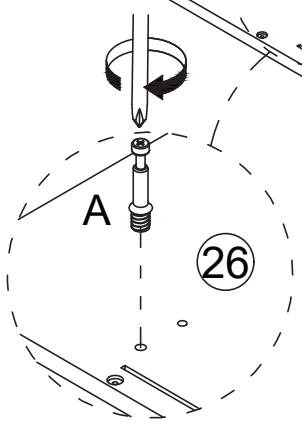

Attention,  
first hole

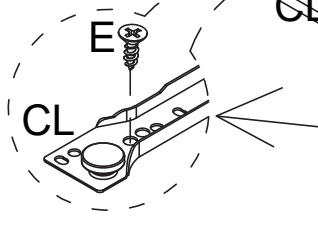
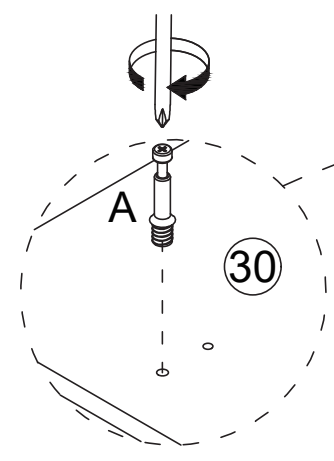

D x6

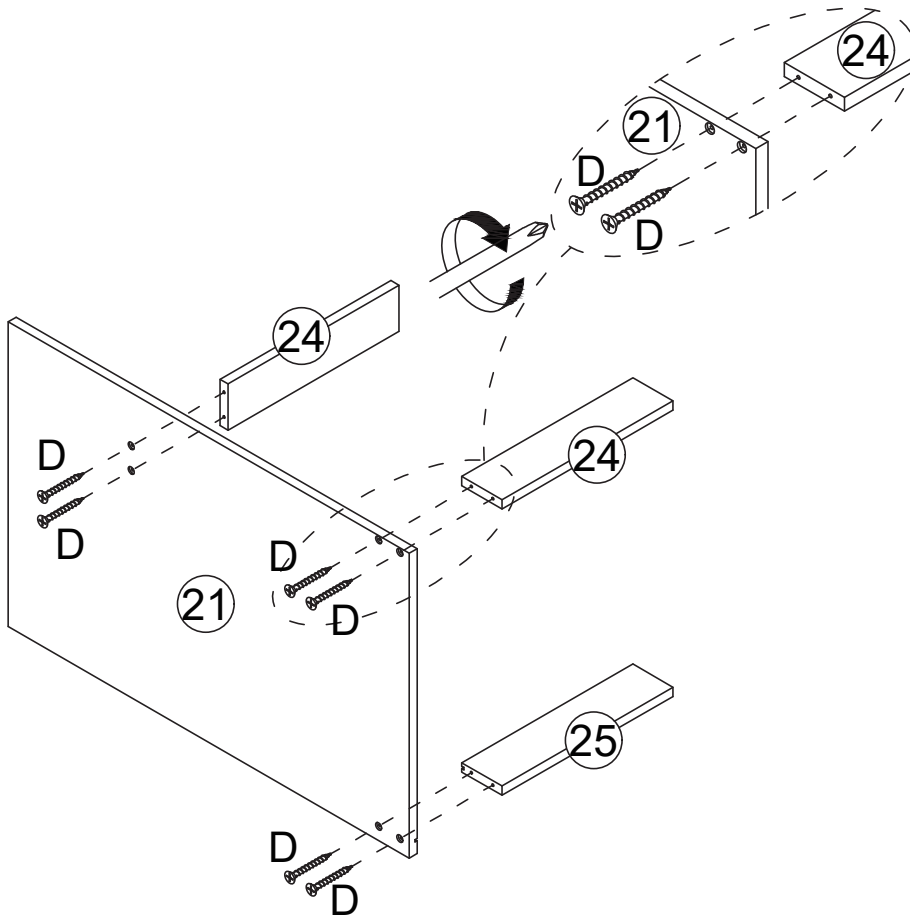

D x6

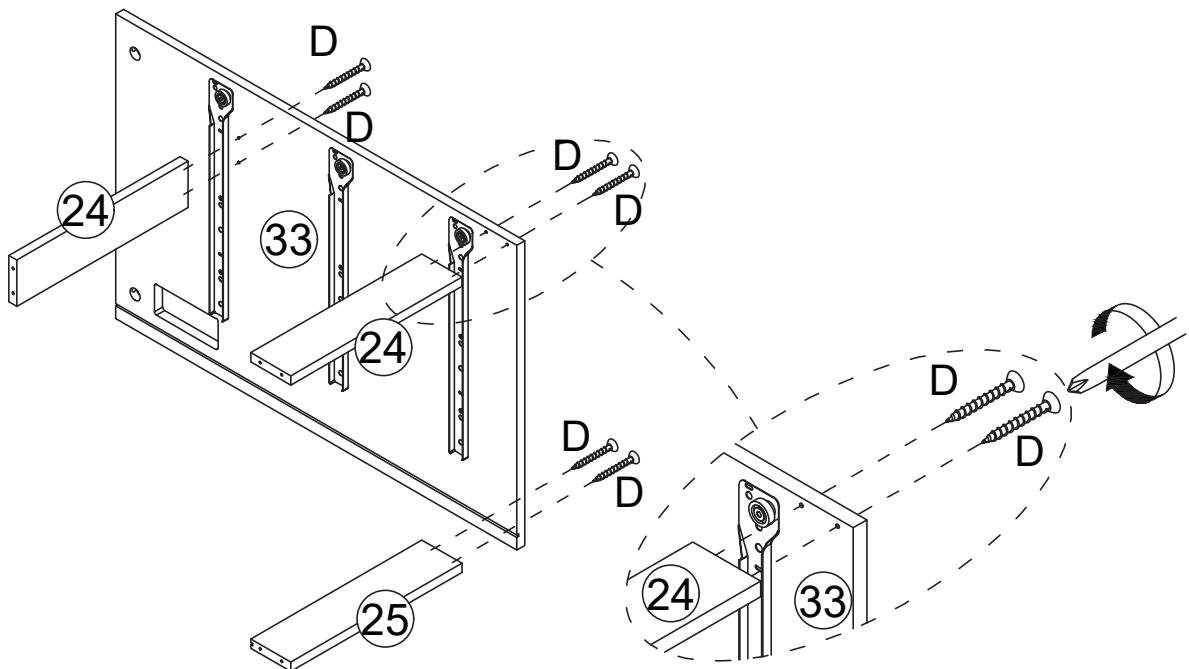

A x4

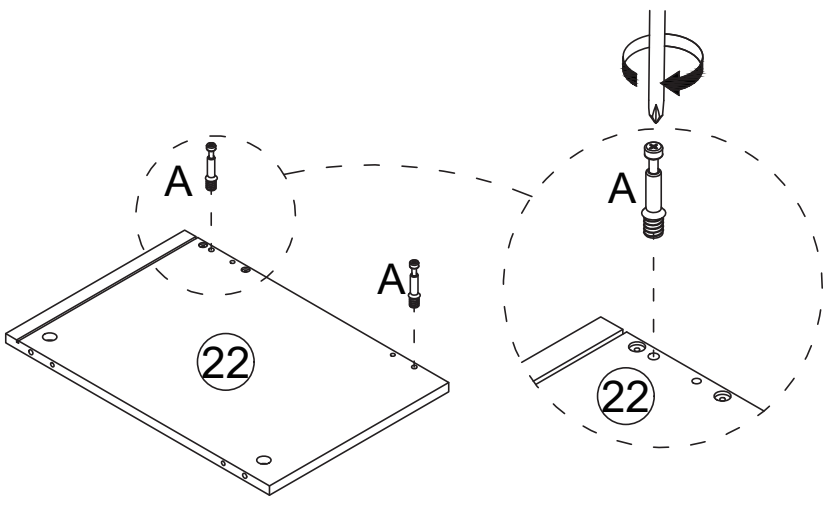
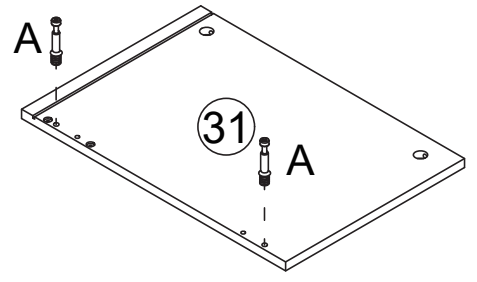
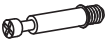

D x4

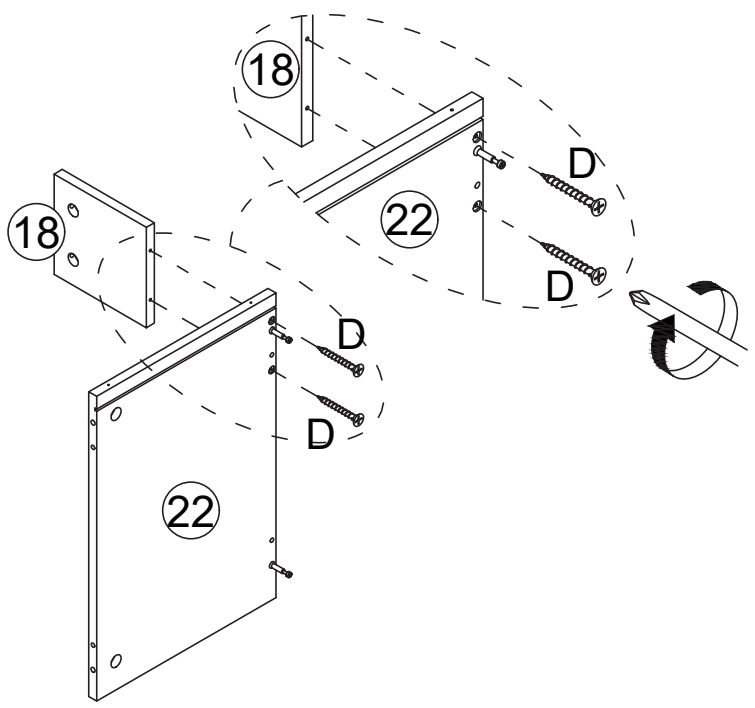
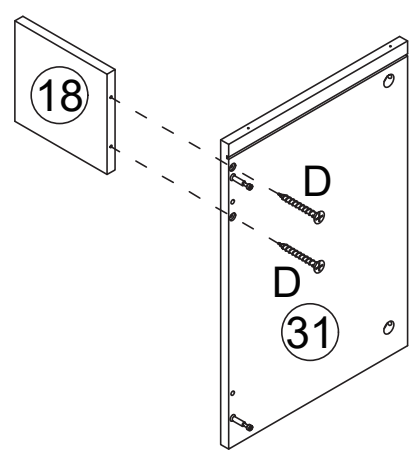

B x2

C x2

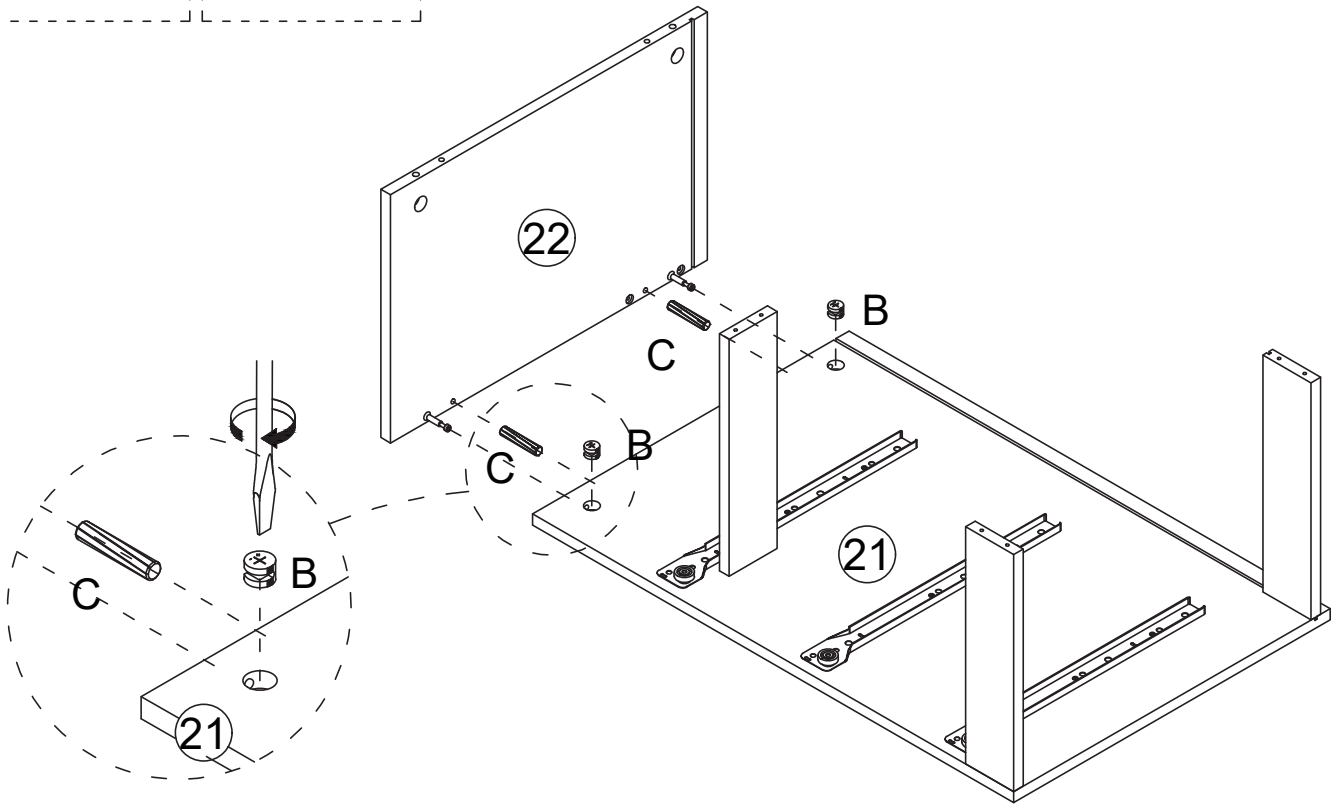

B x2

C x2

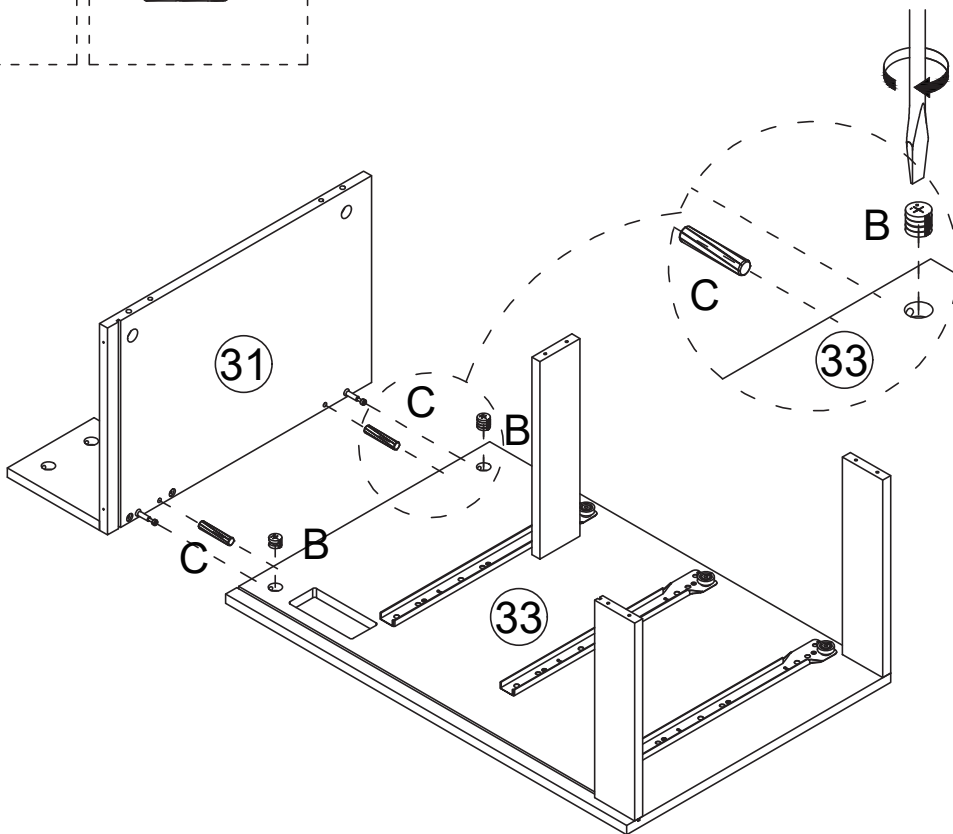

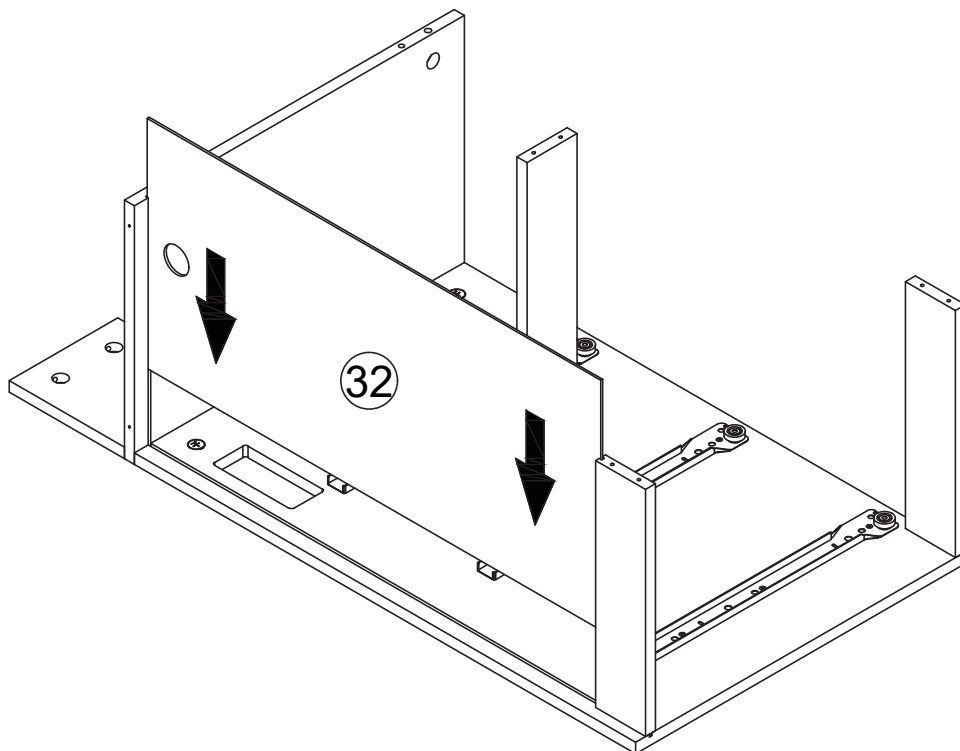
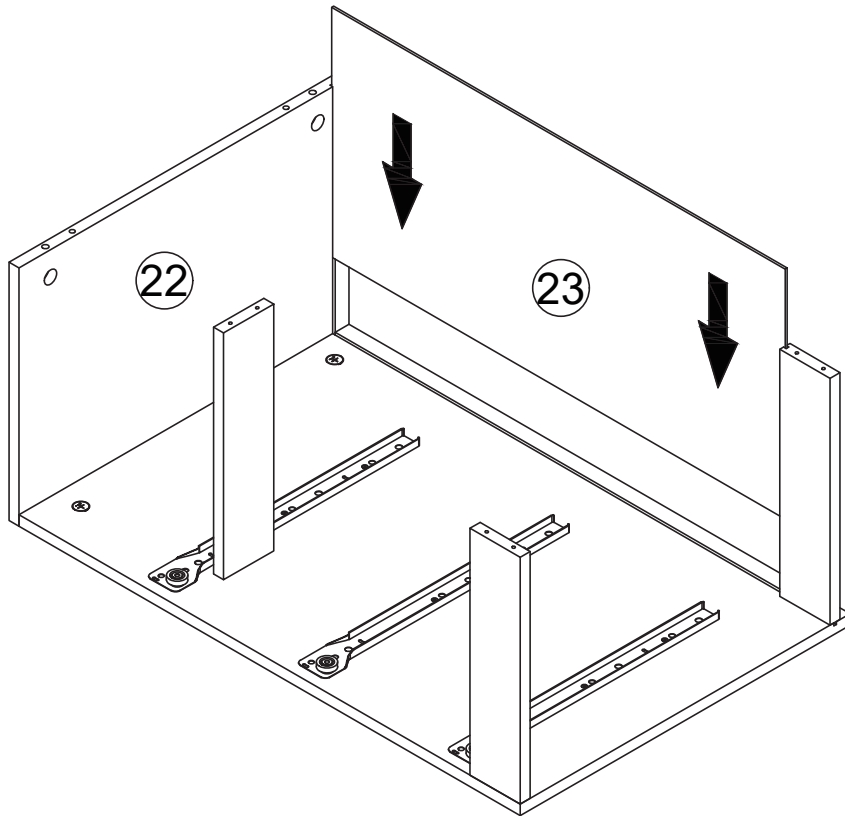

B x2

C x2

D x6

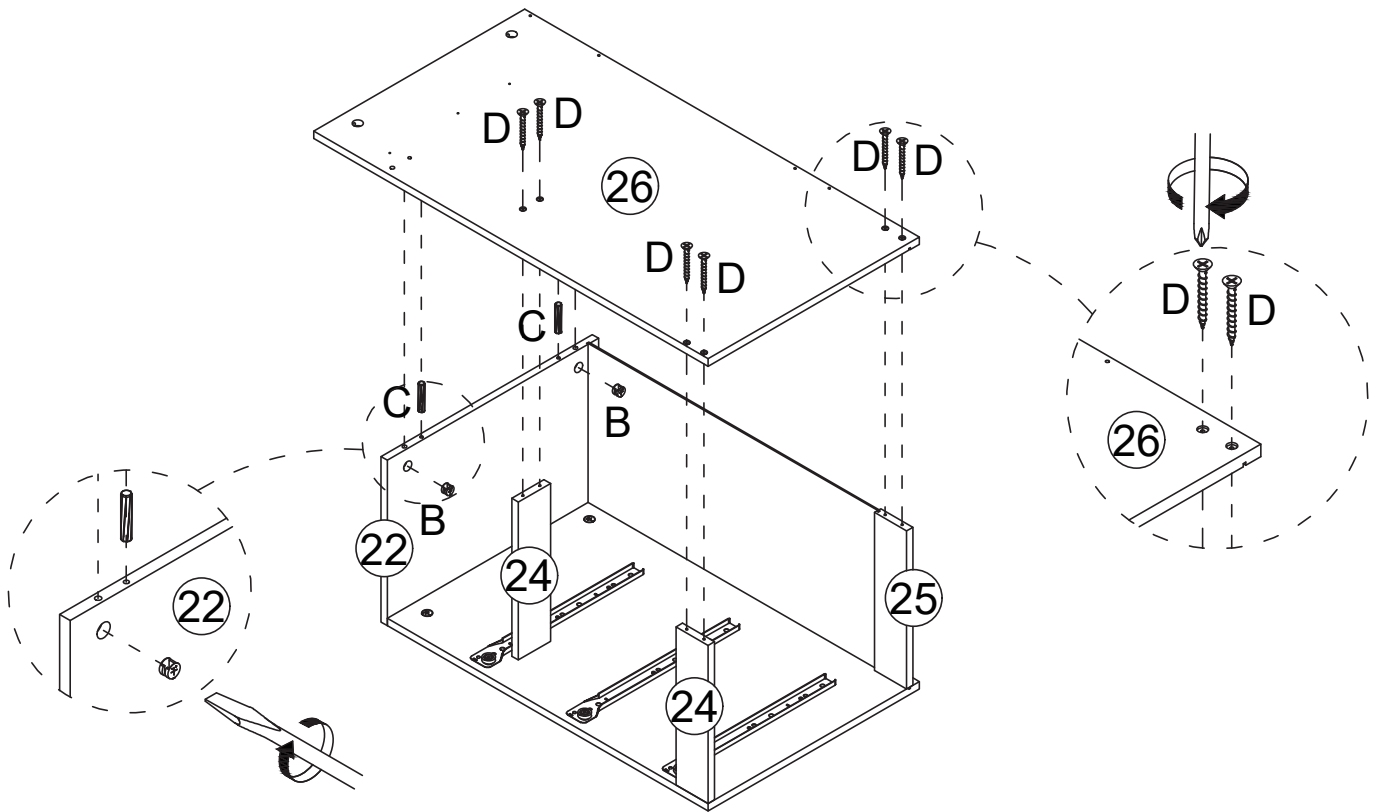

B x2

C x2

D x6

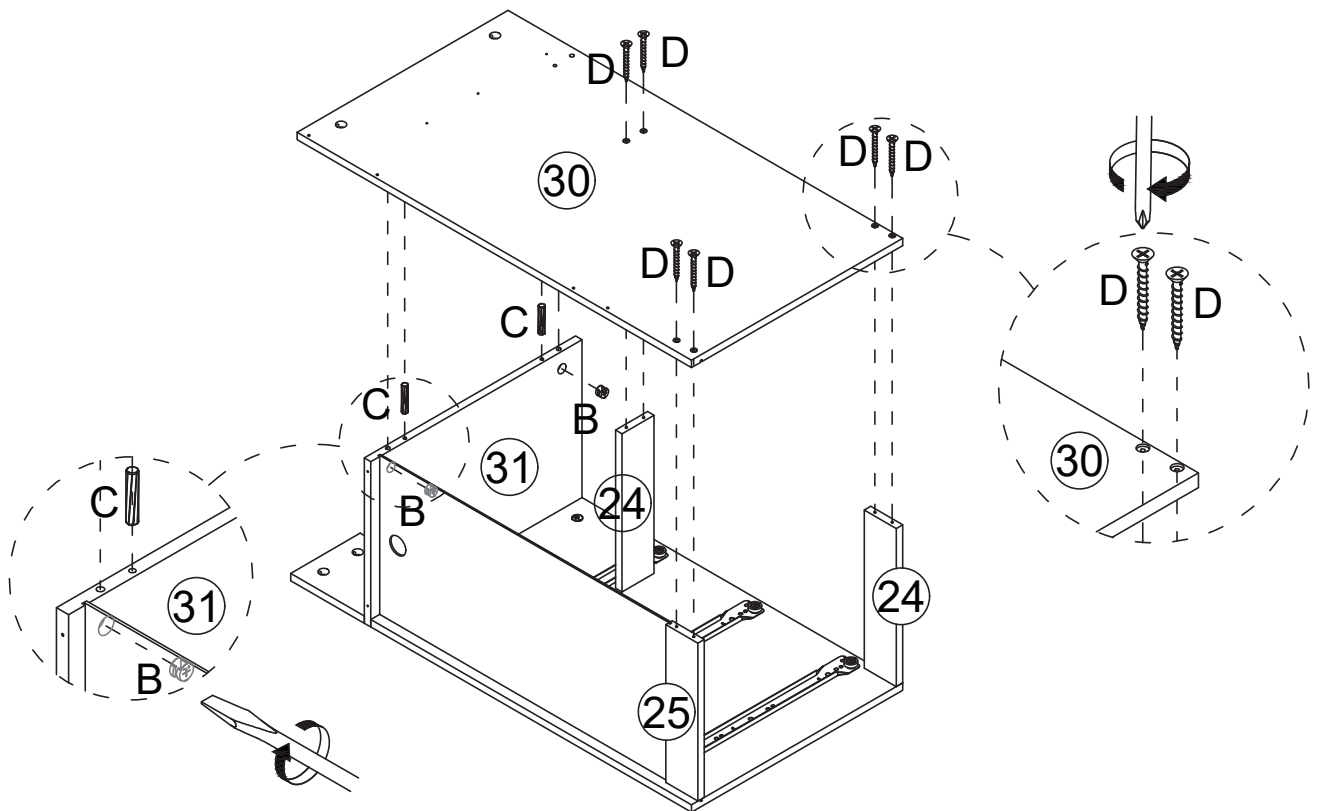

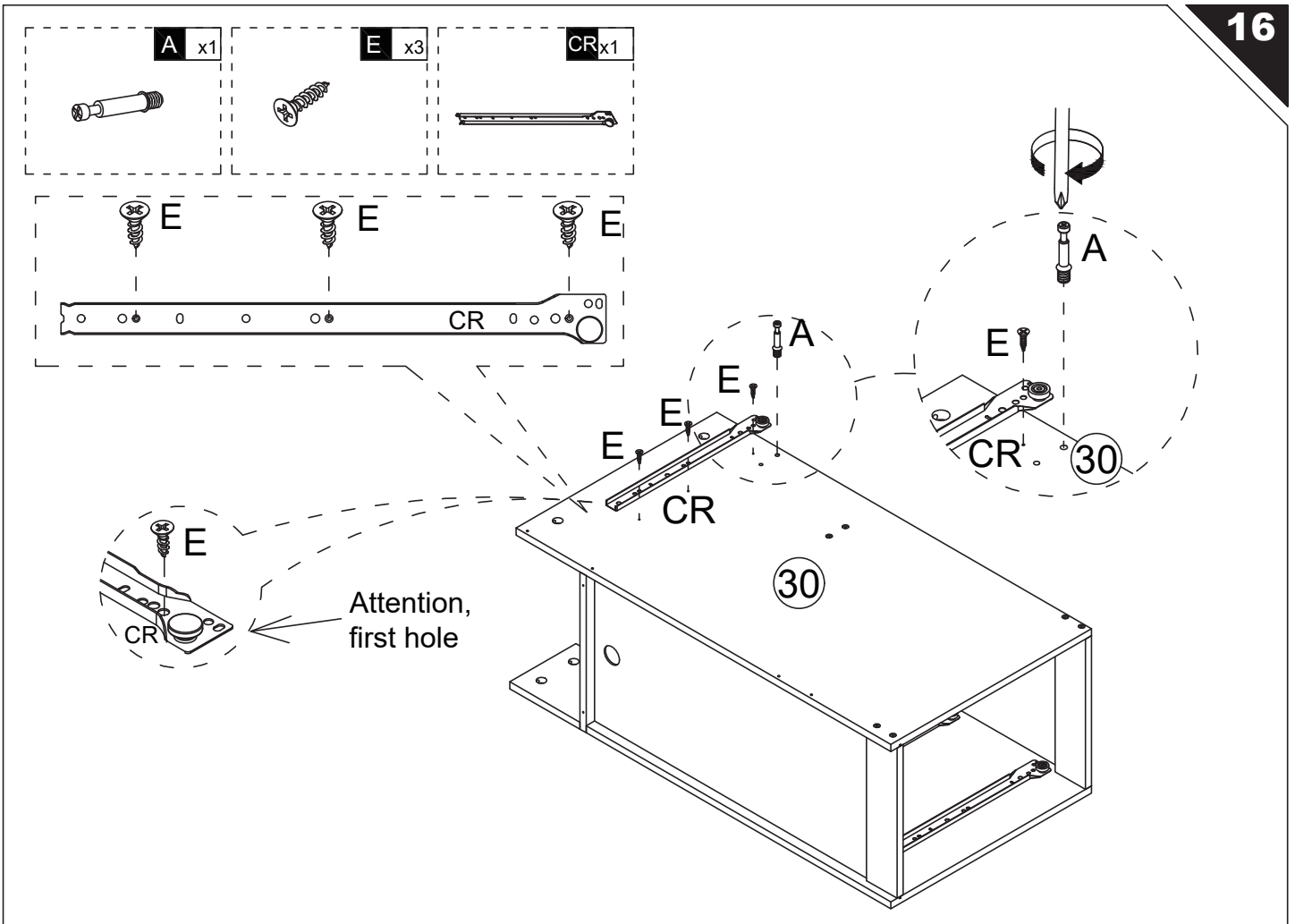
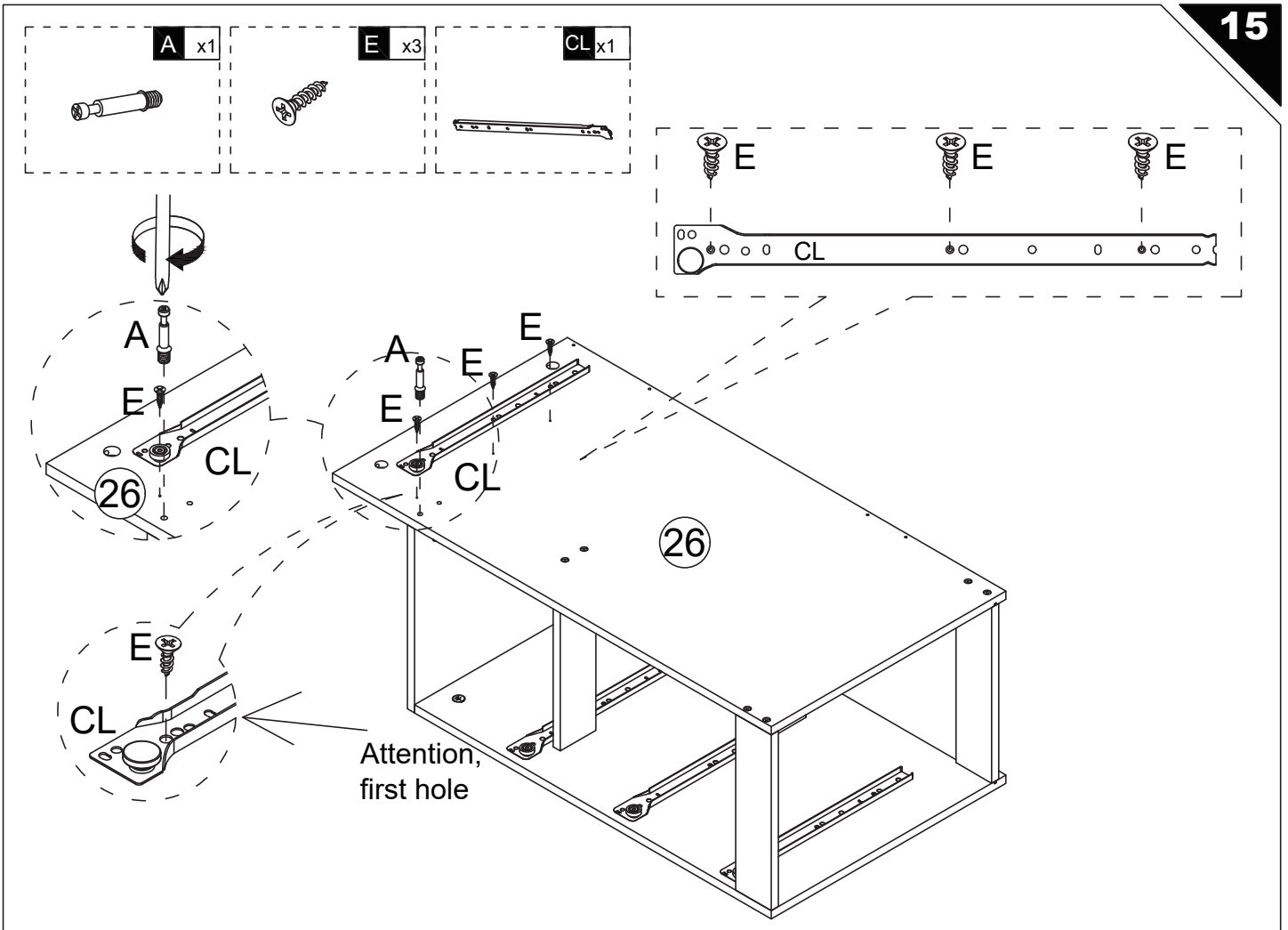

B x2



C x2



D x8

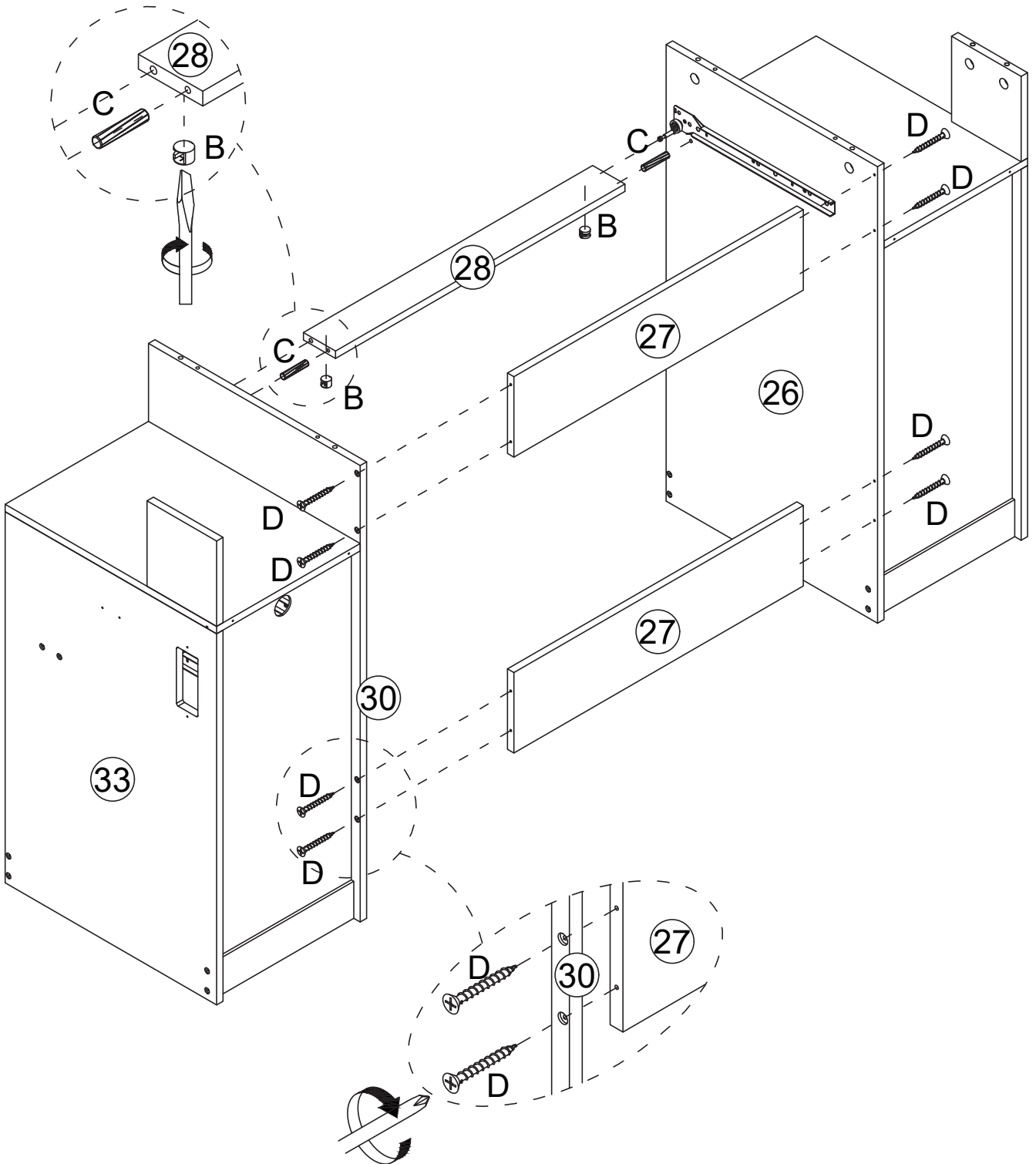

A x4

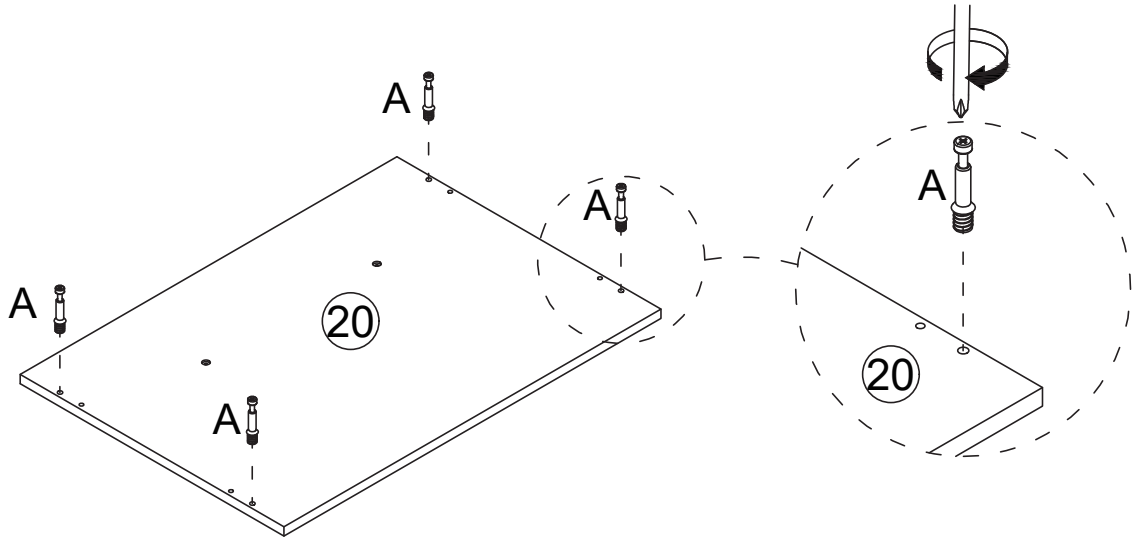
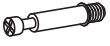

A x2

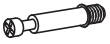

B x2

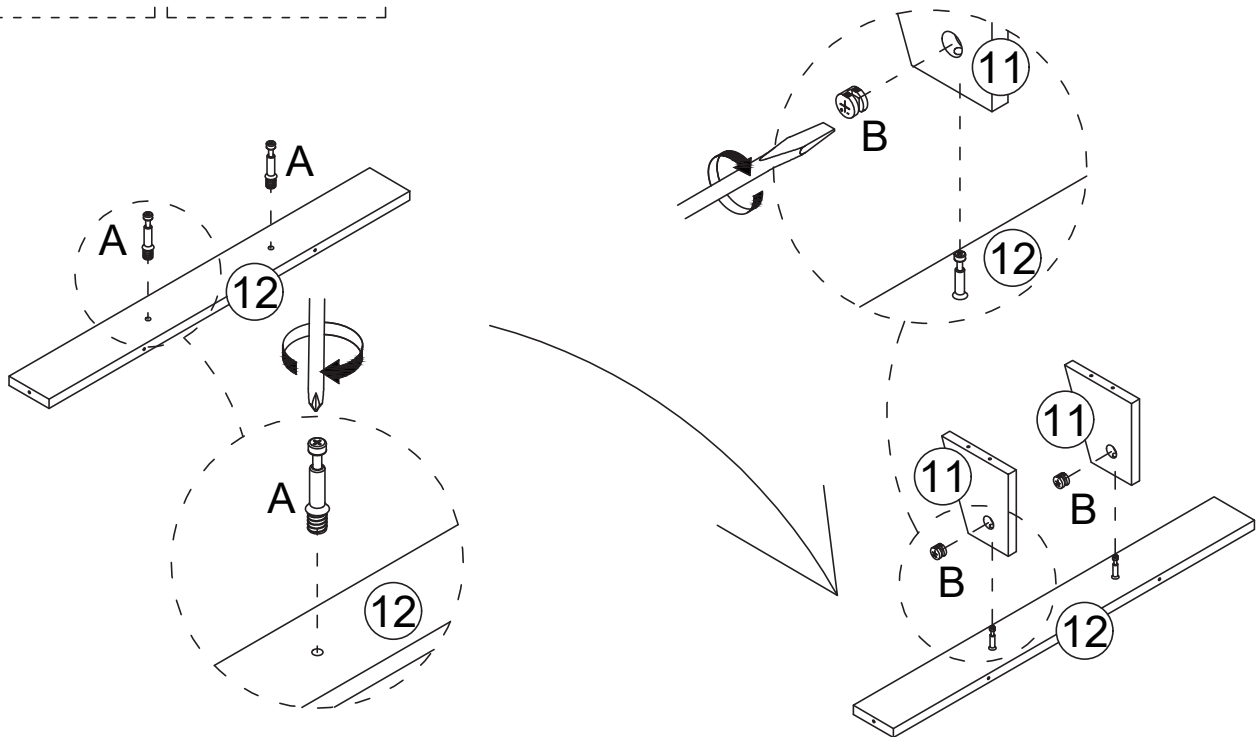

B x4



C x4



D x2

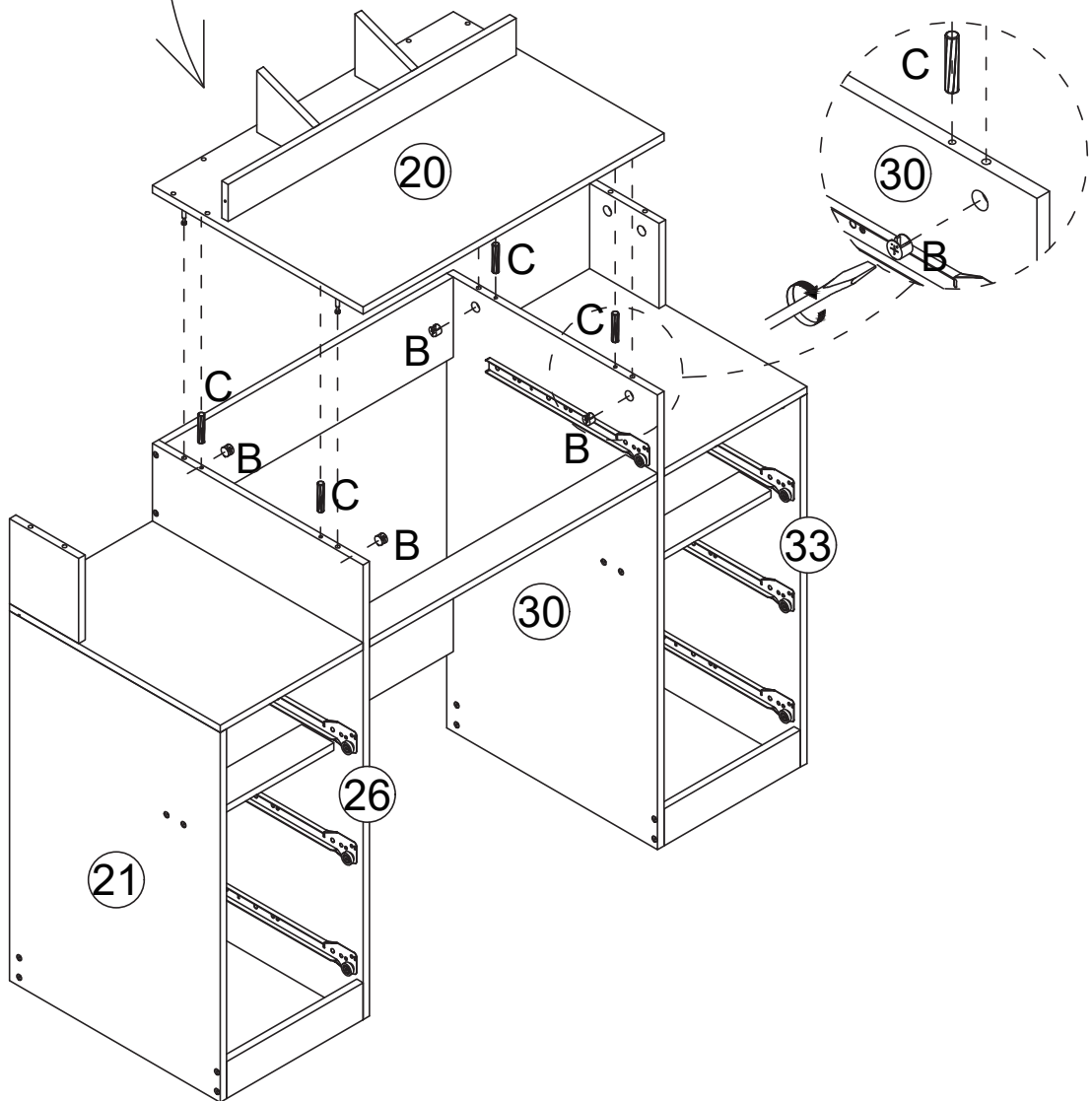
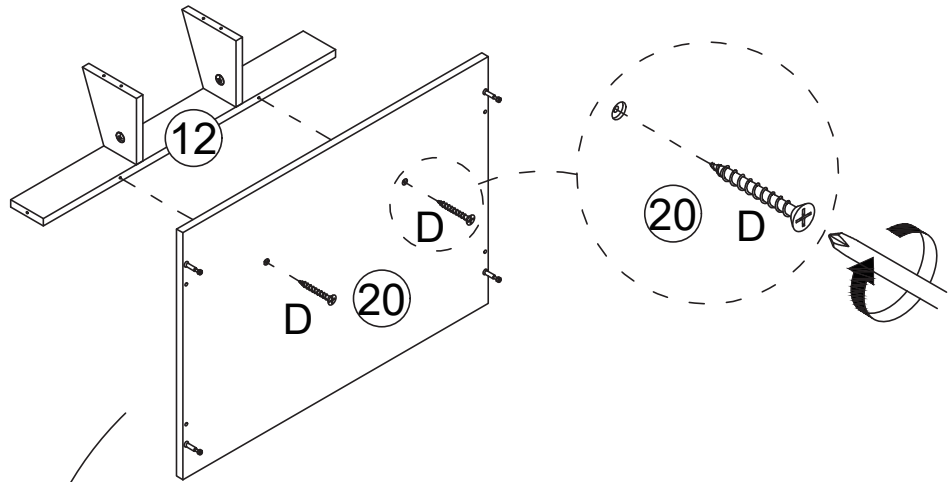

A x4

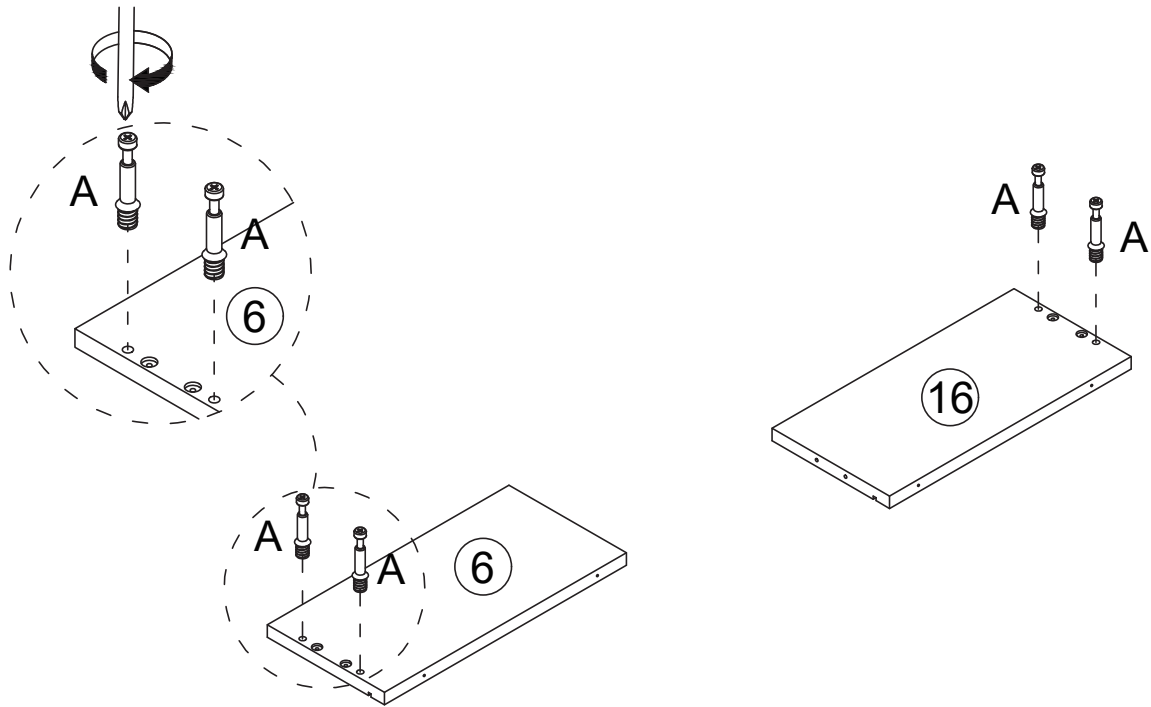
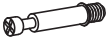

D x4

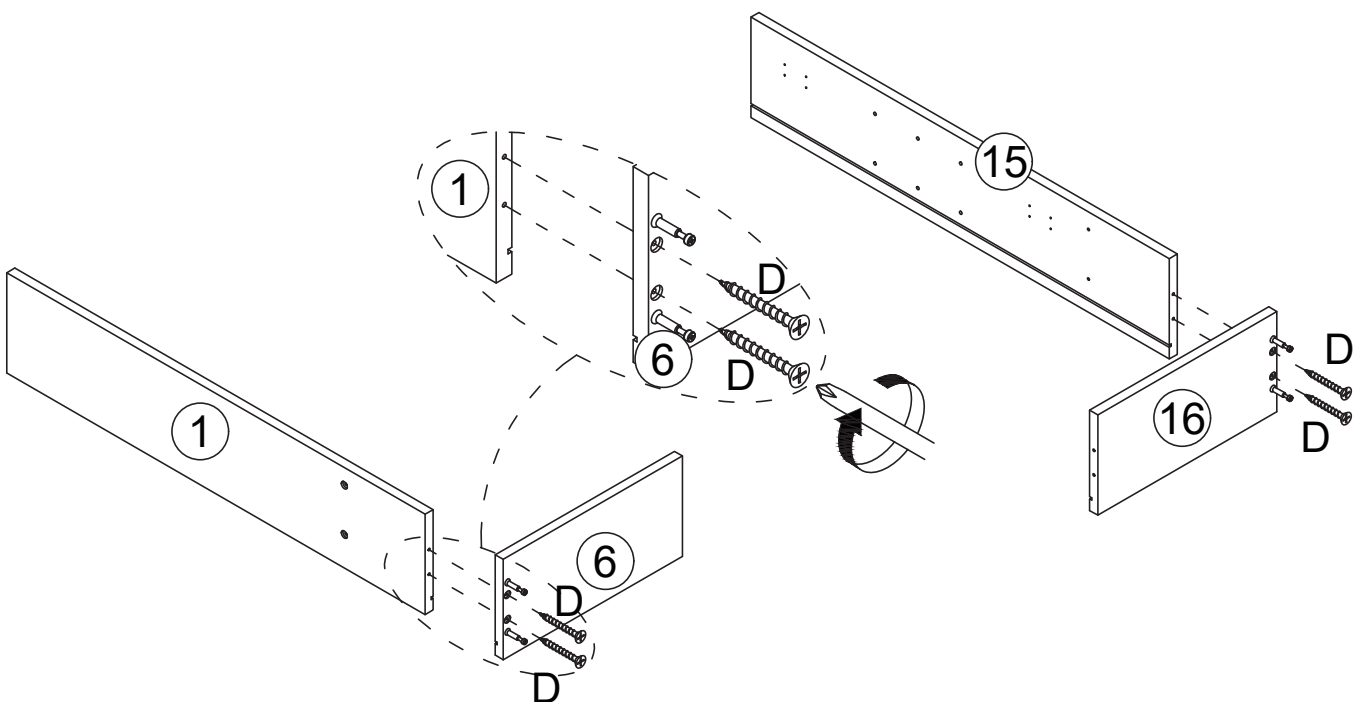

D x4

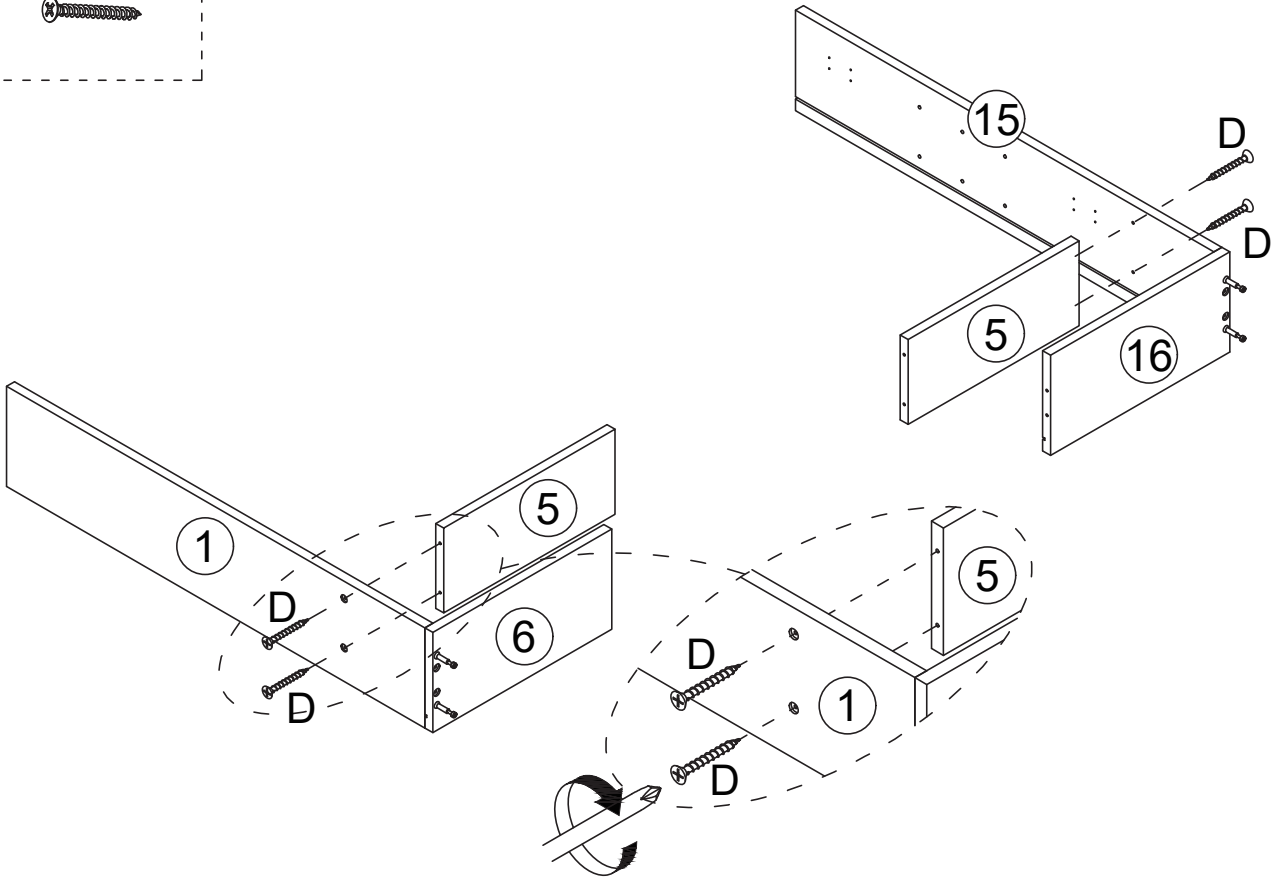

D x8

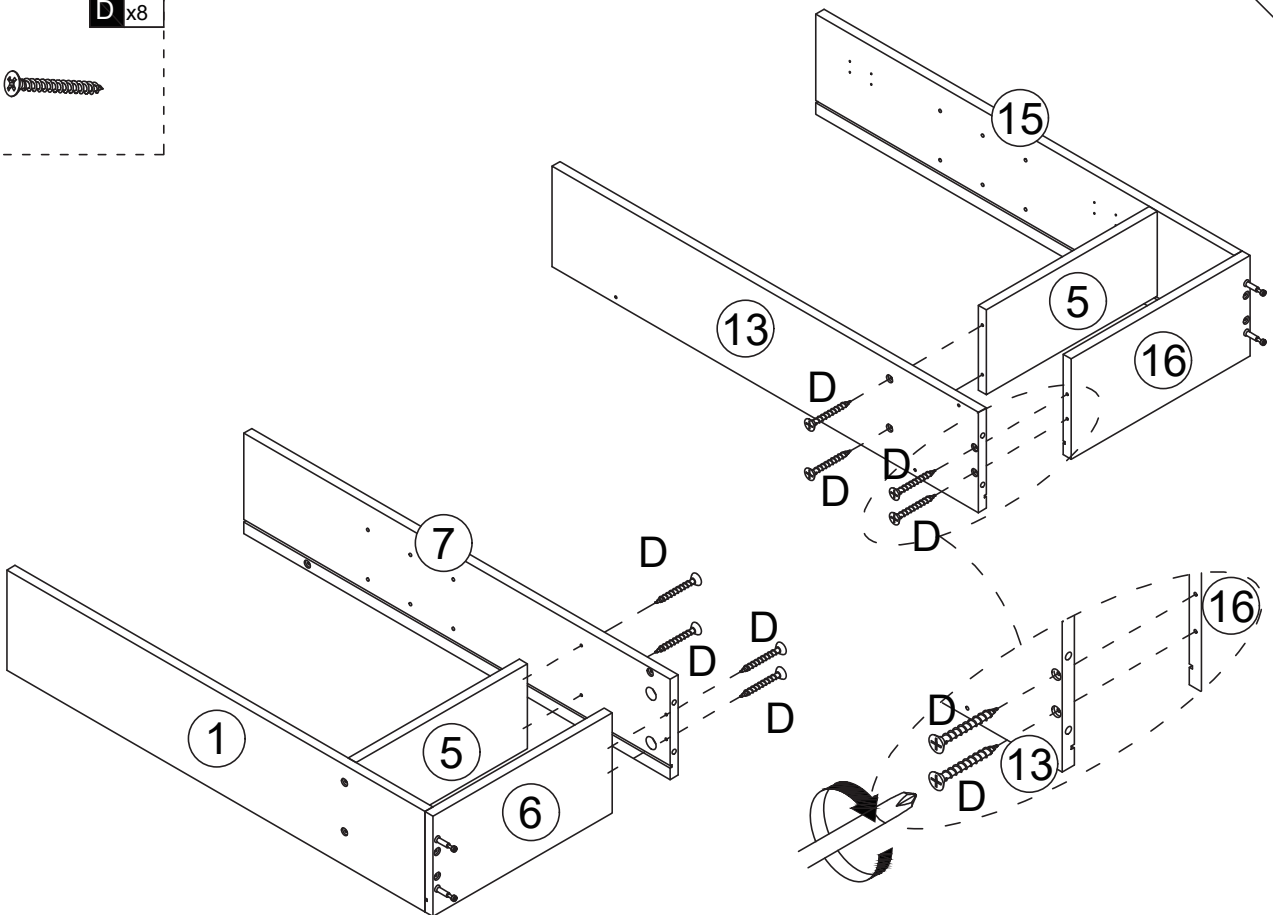

A x6

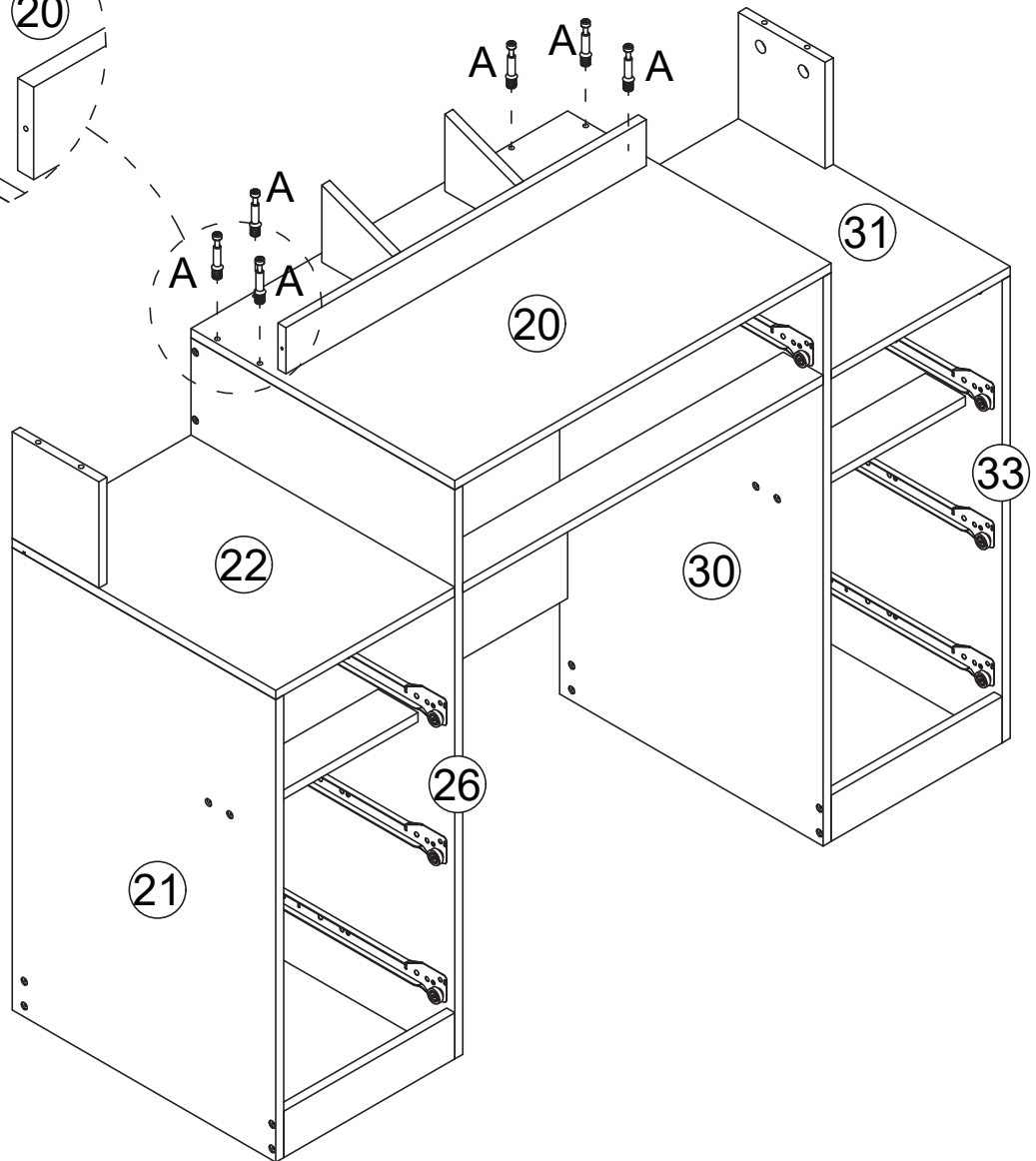
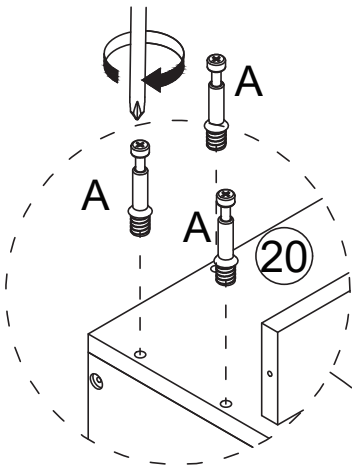

B x8

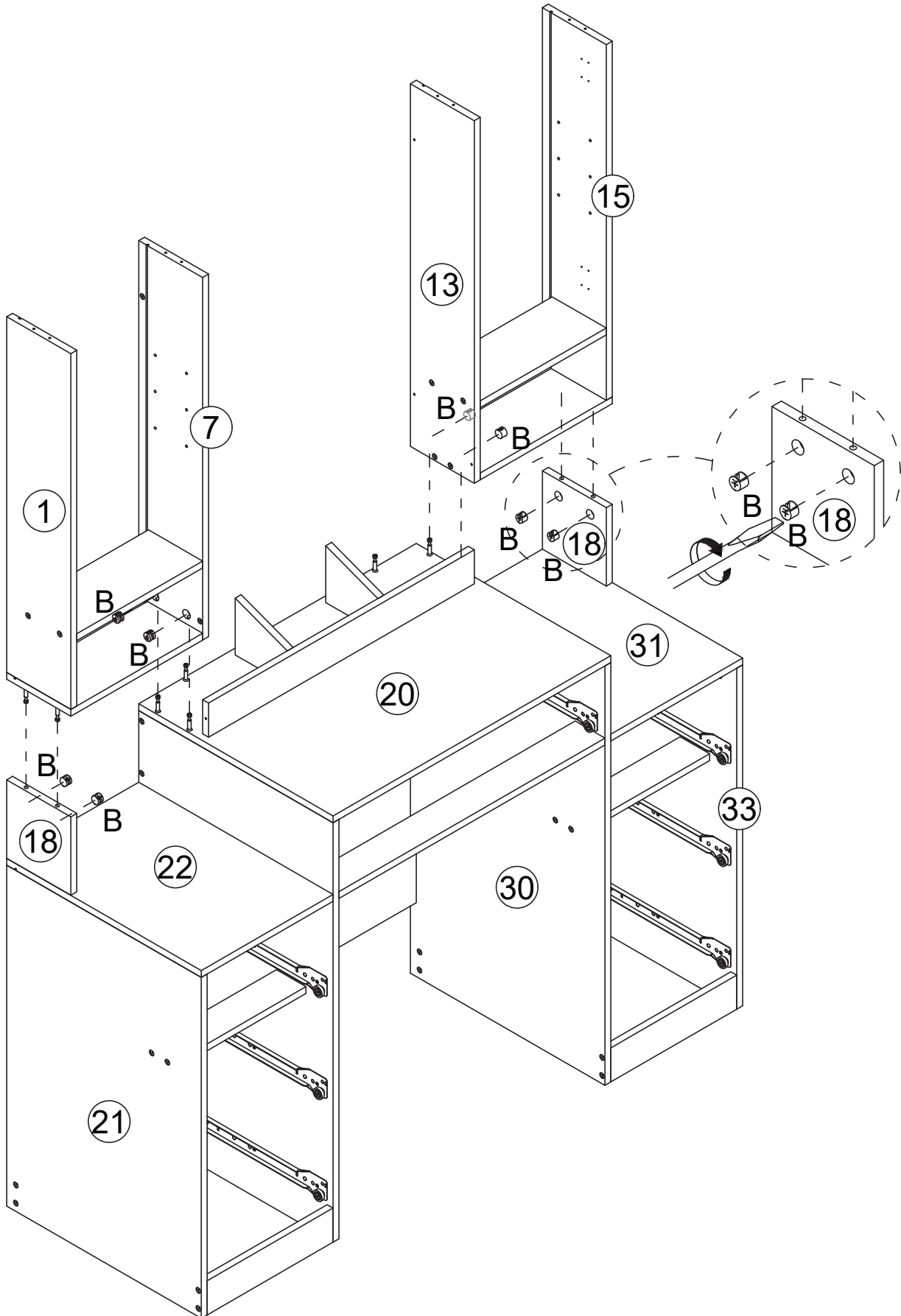

B x2

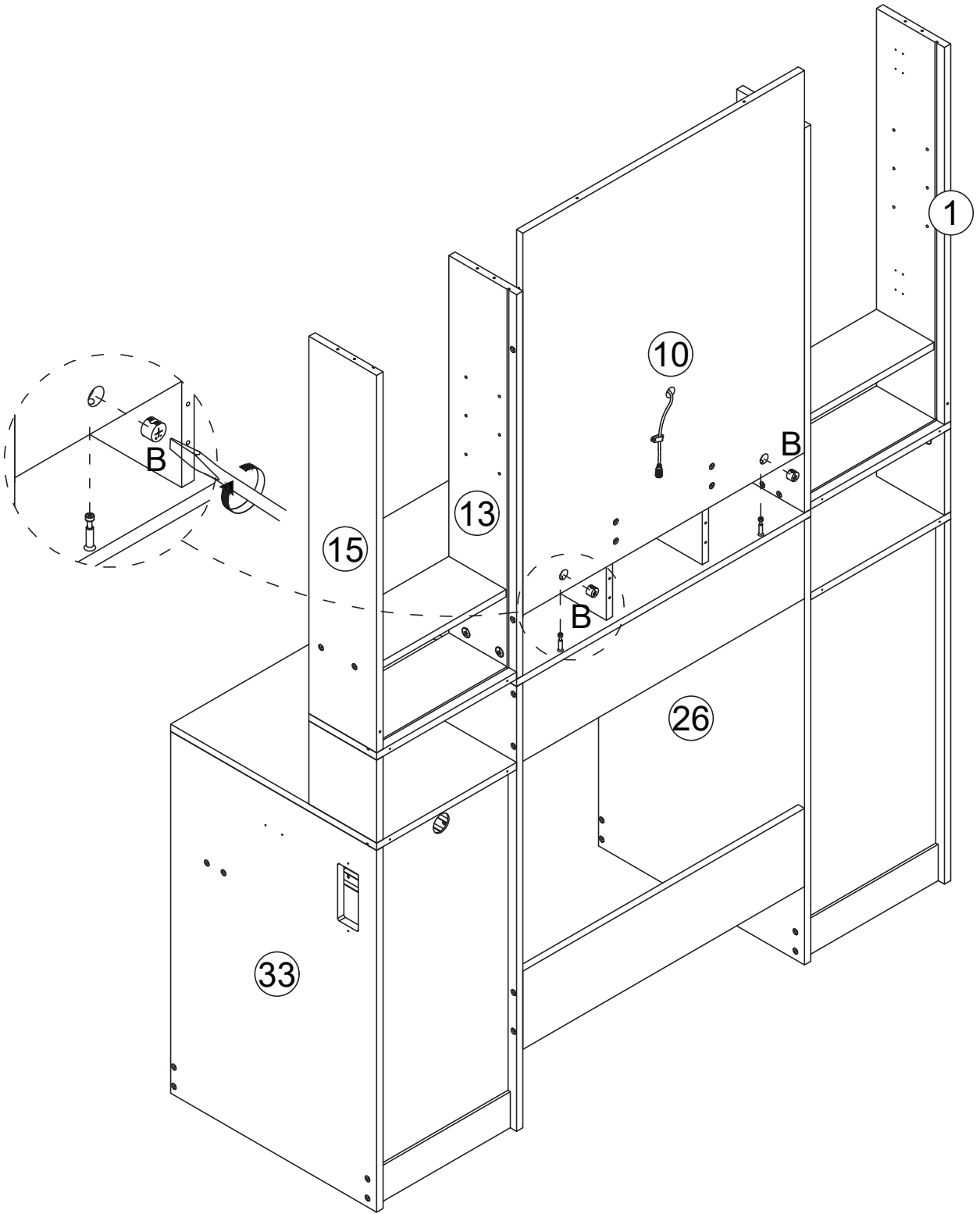

D x8

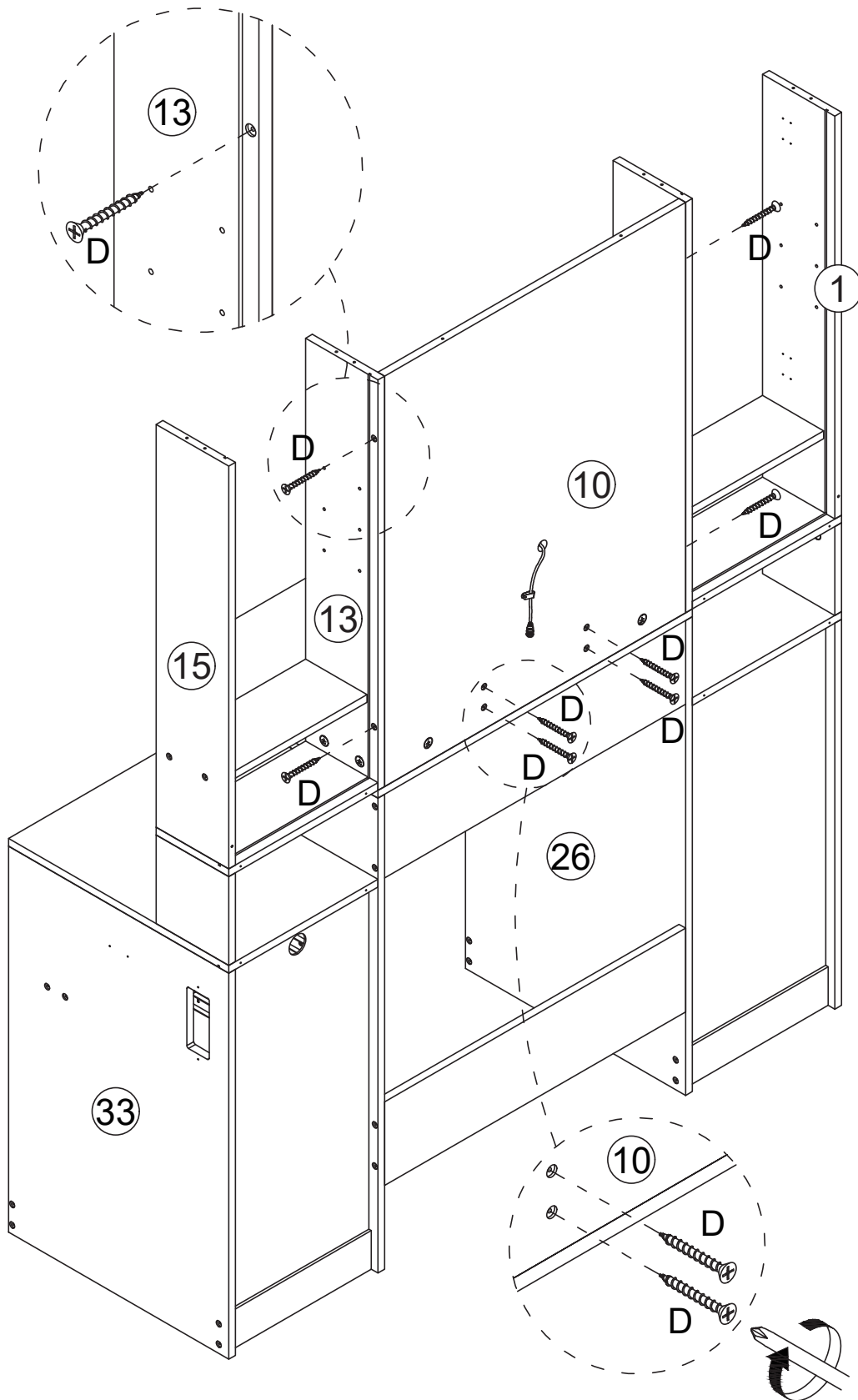

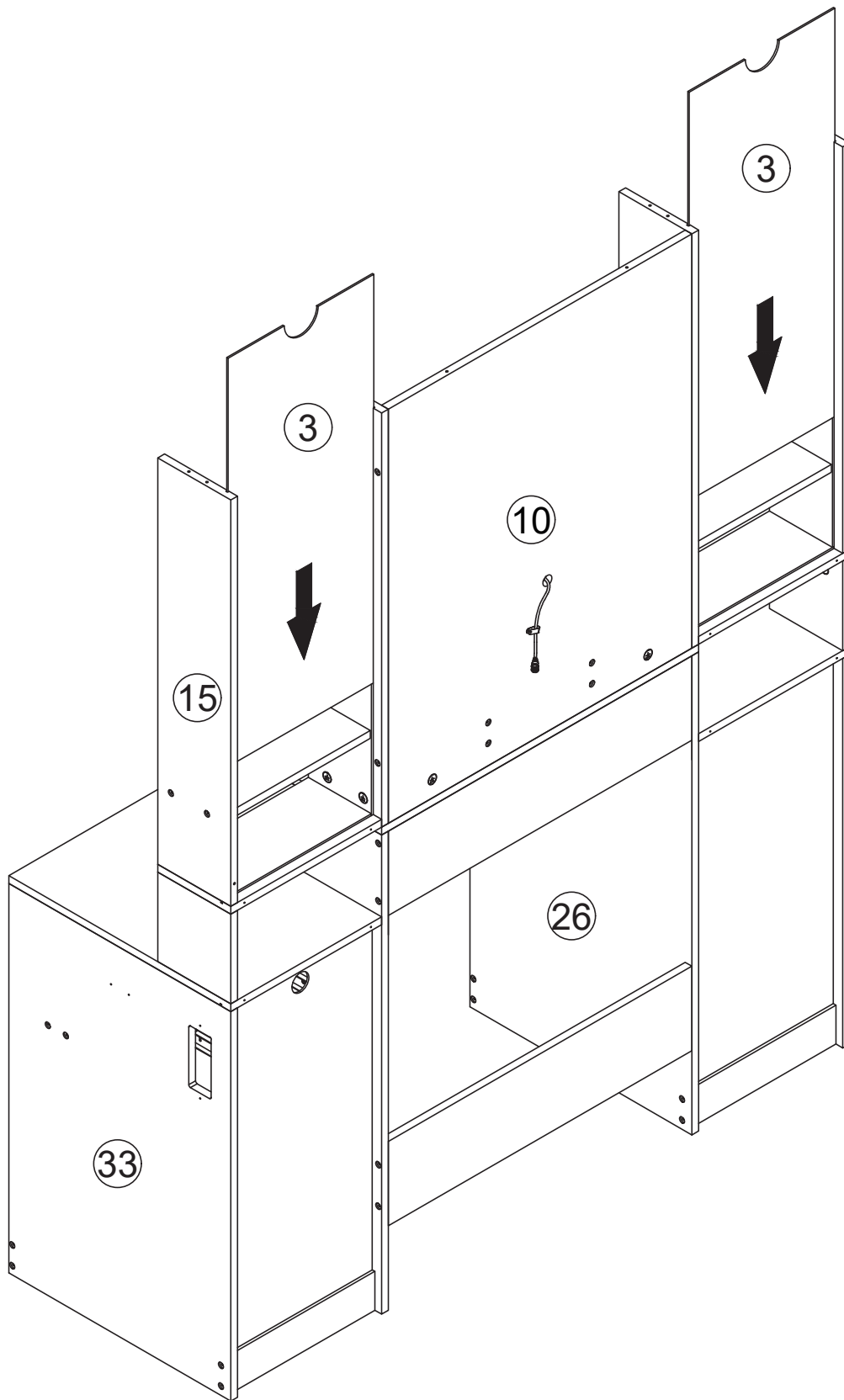



D x10

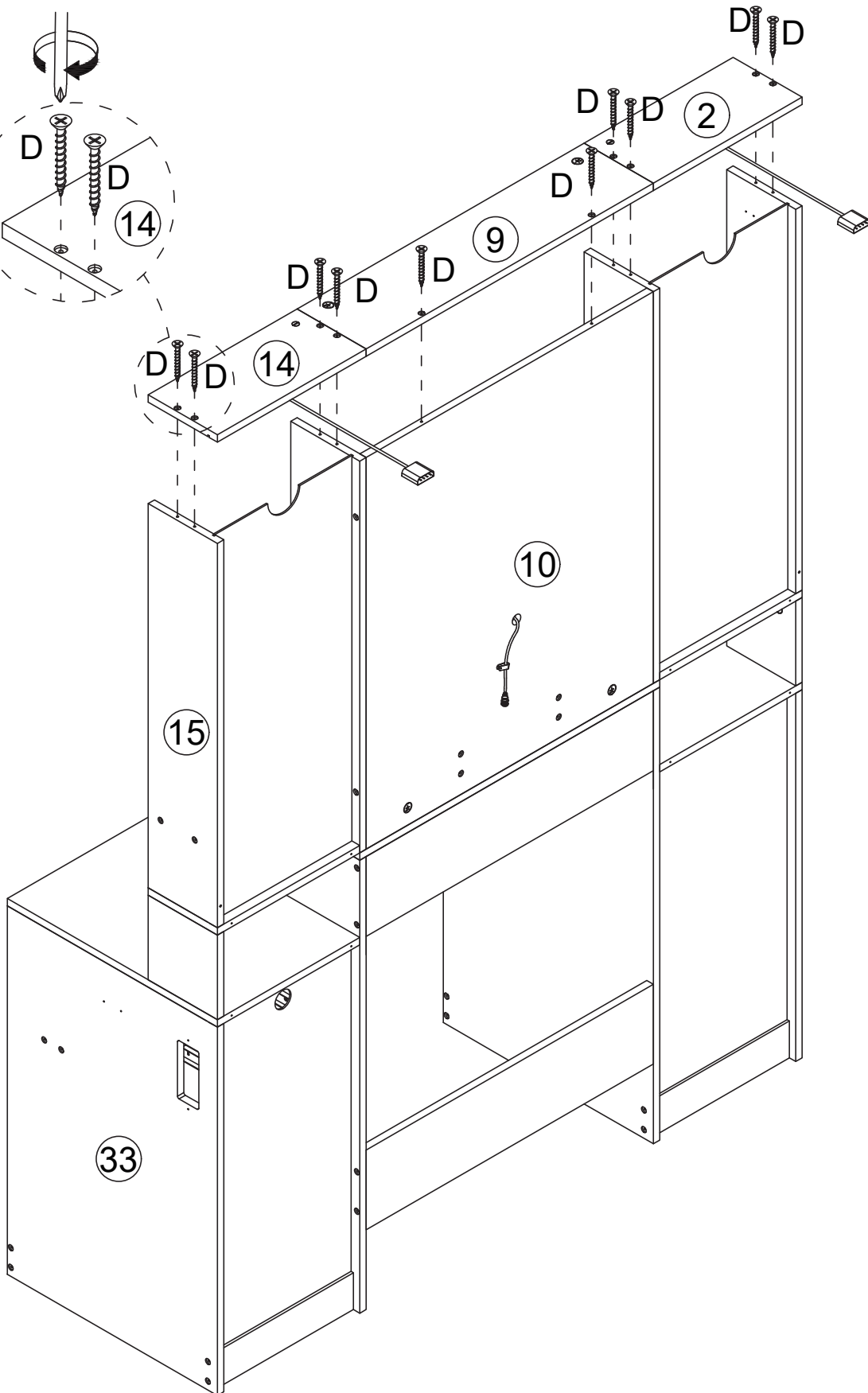
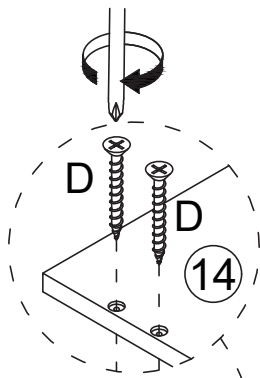

W x8

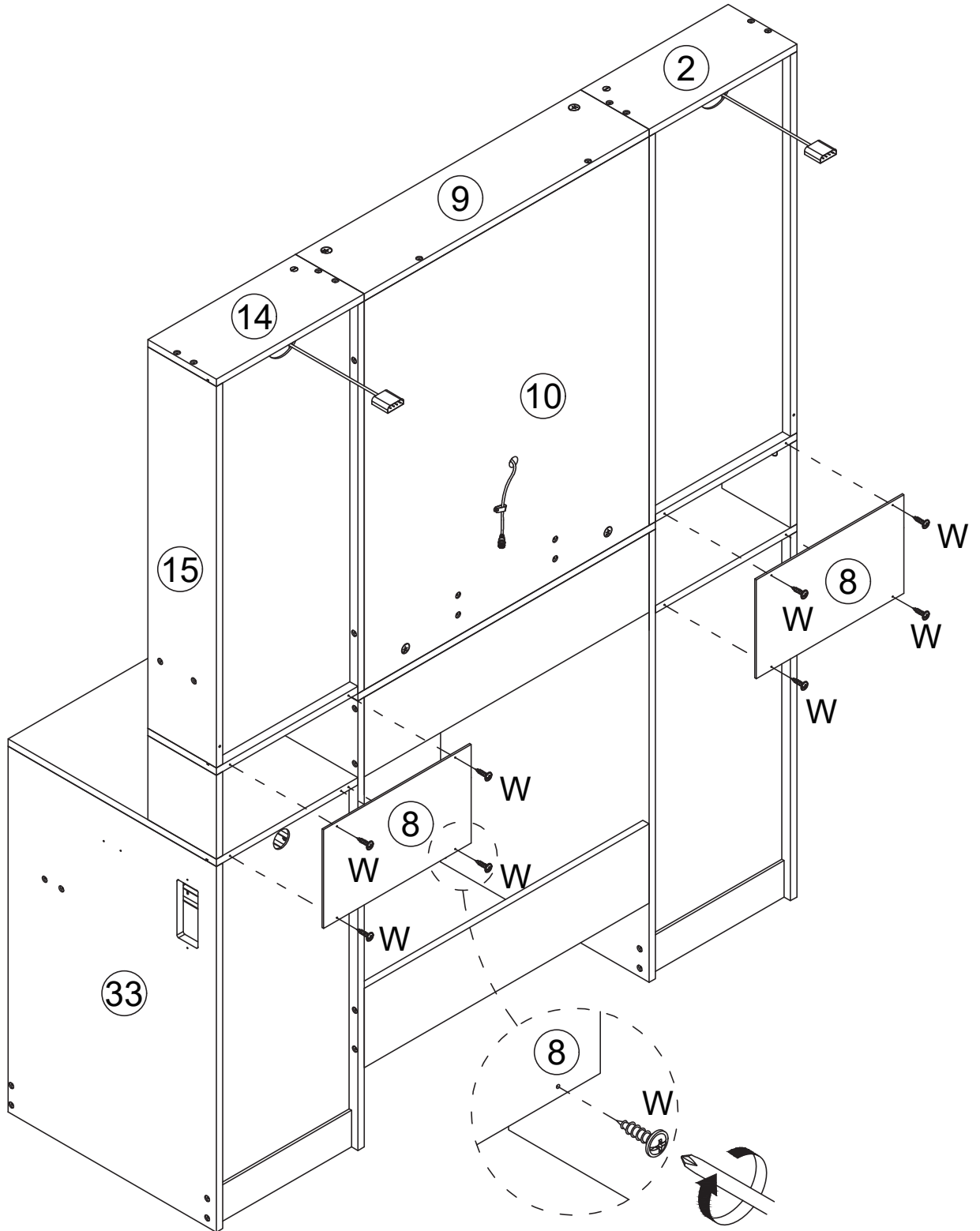
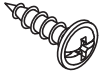

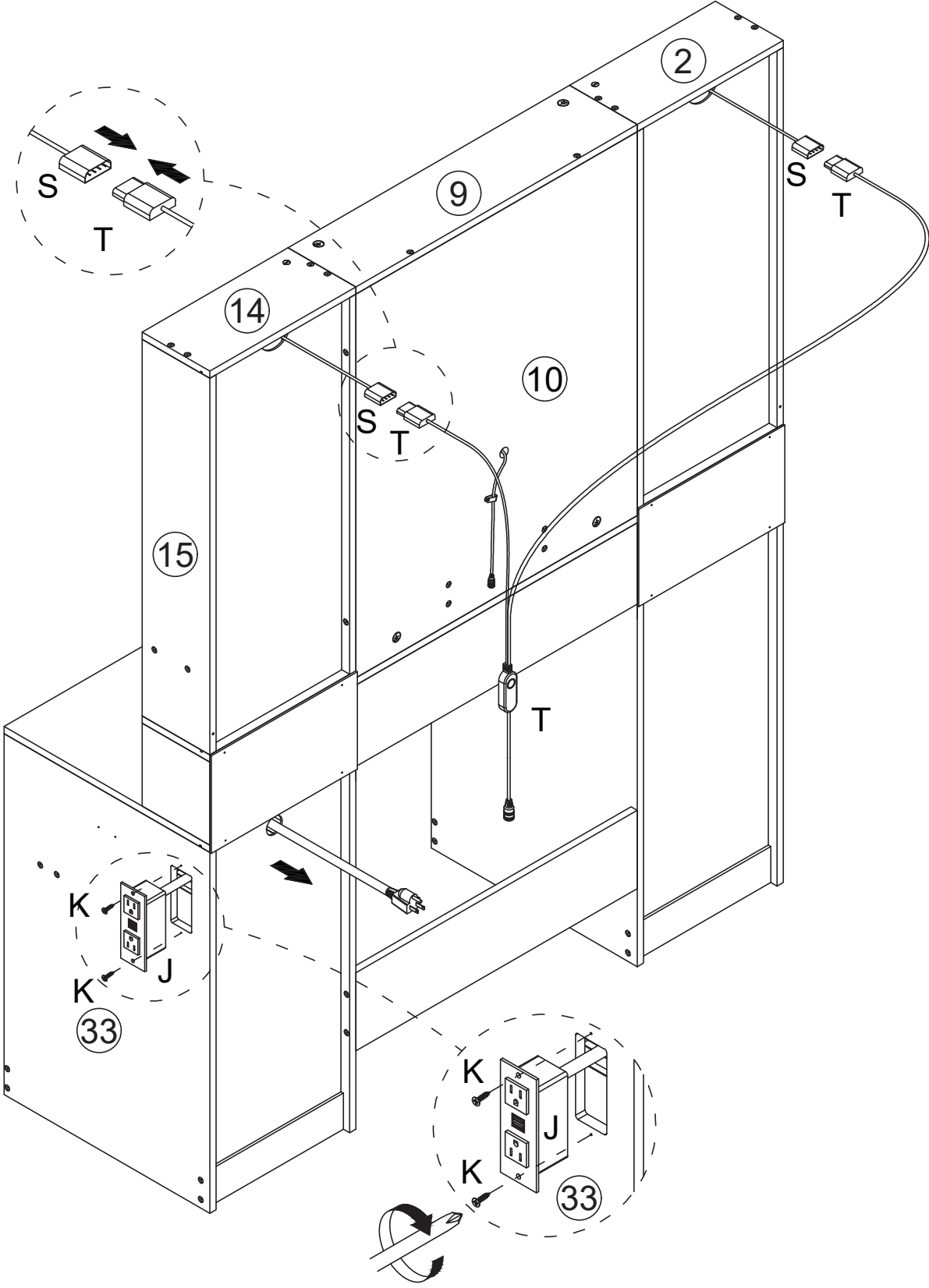
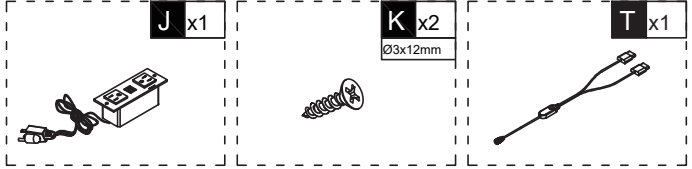

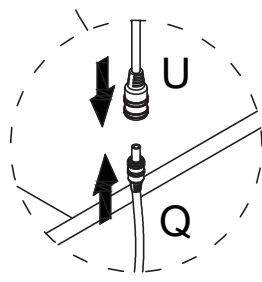
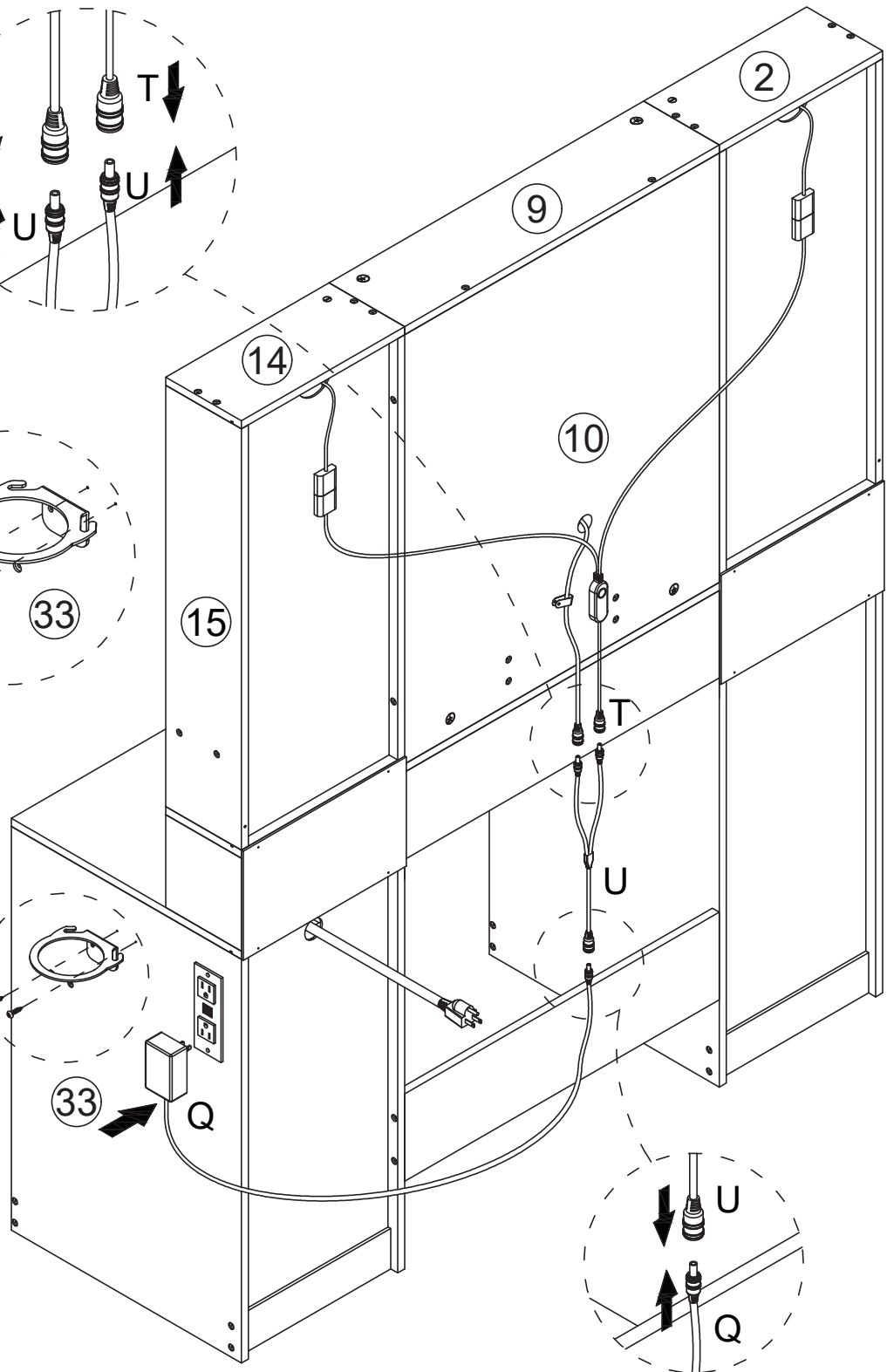
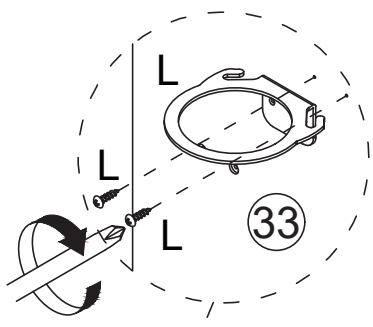
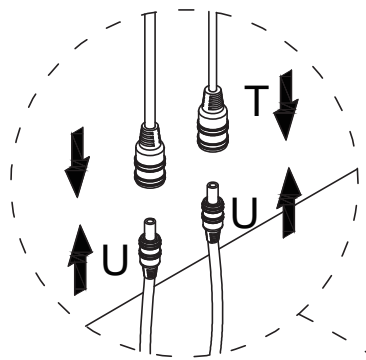
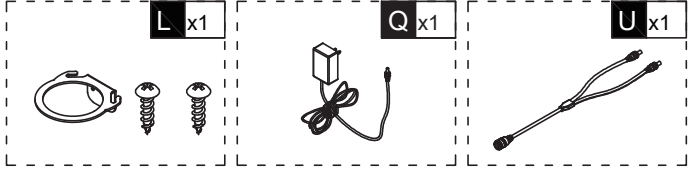

CC x16

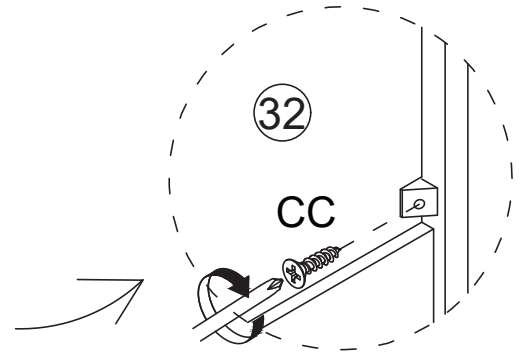
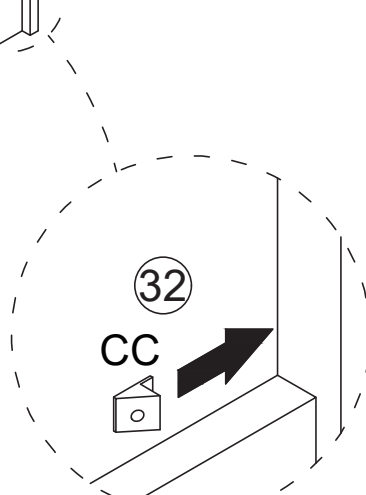
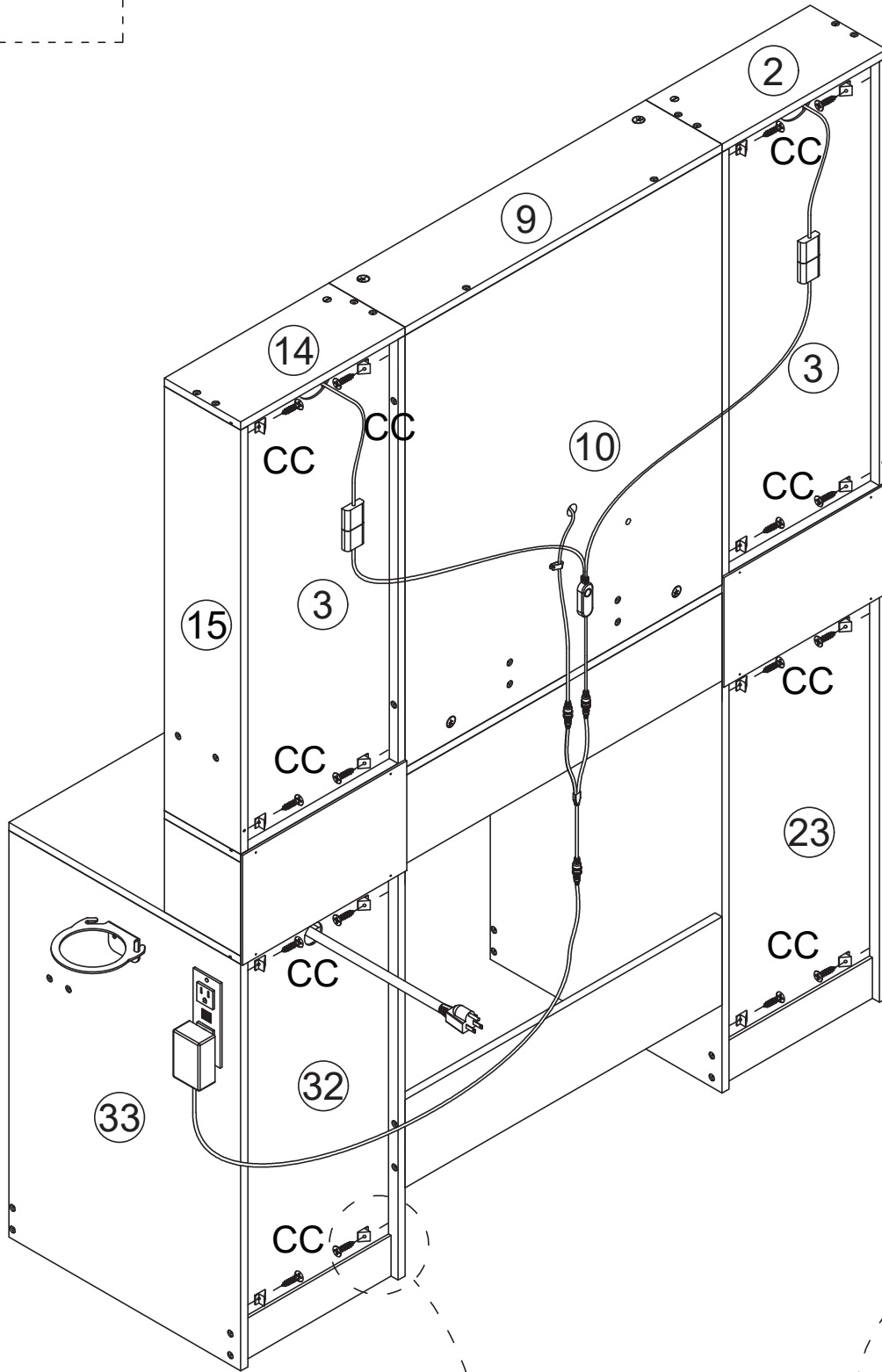

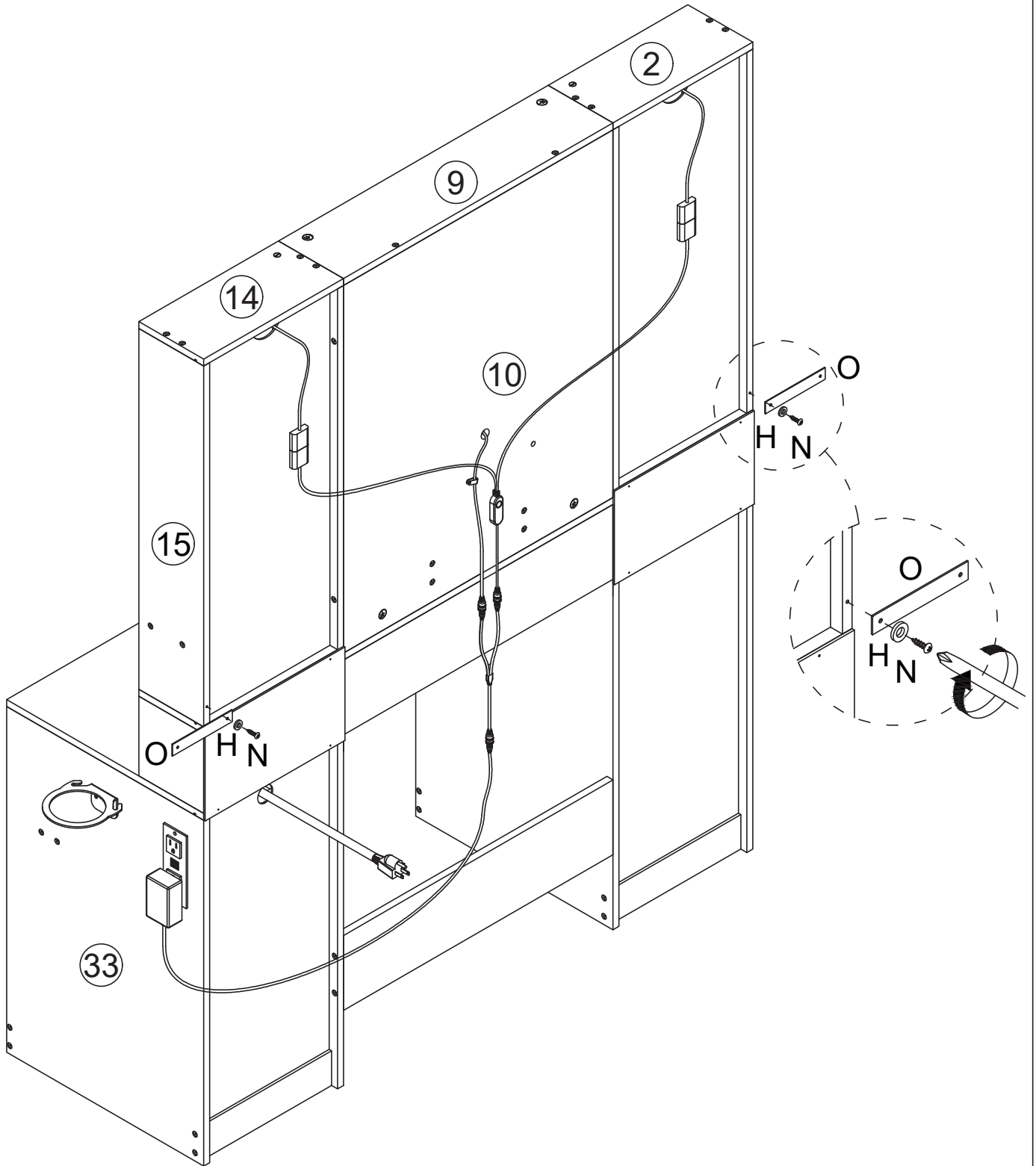
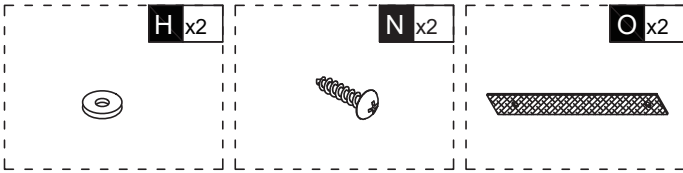

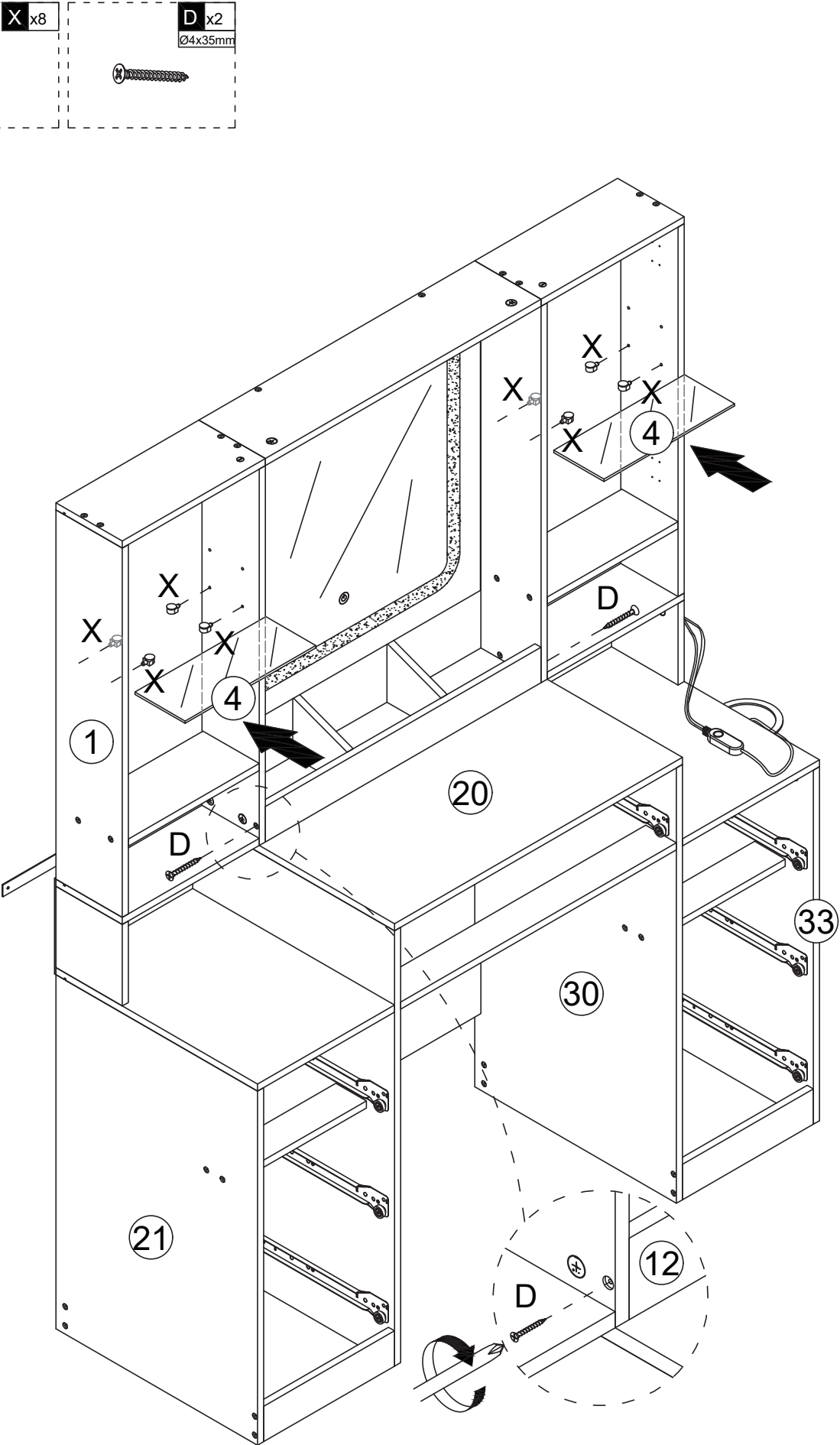

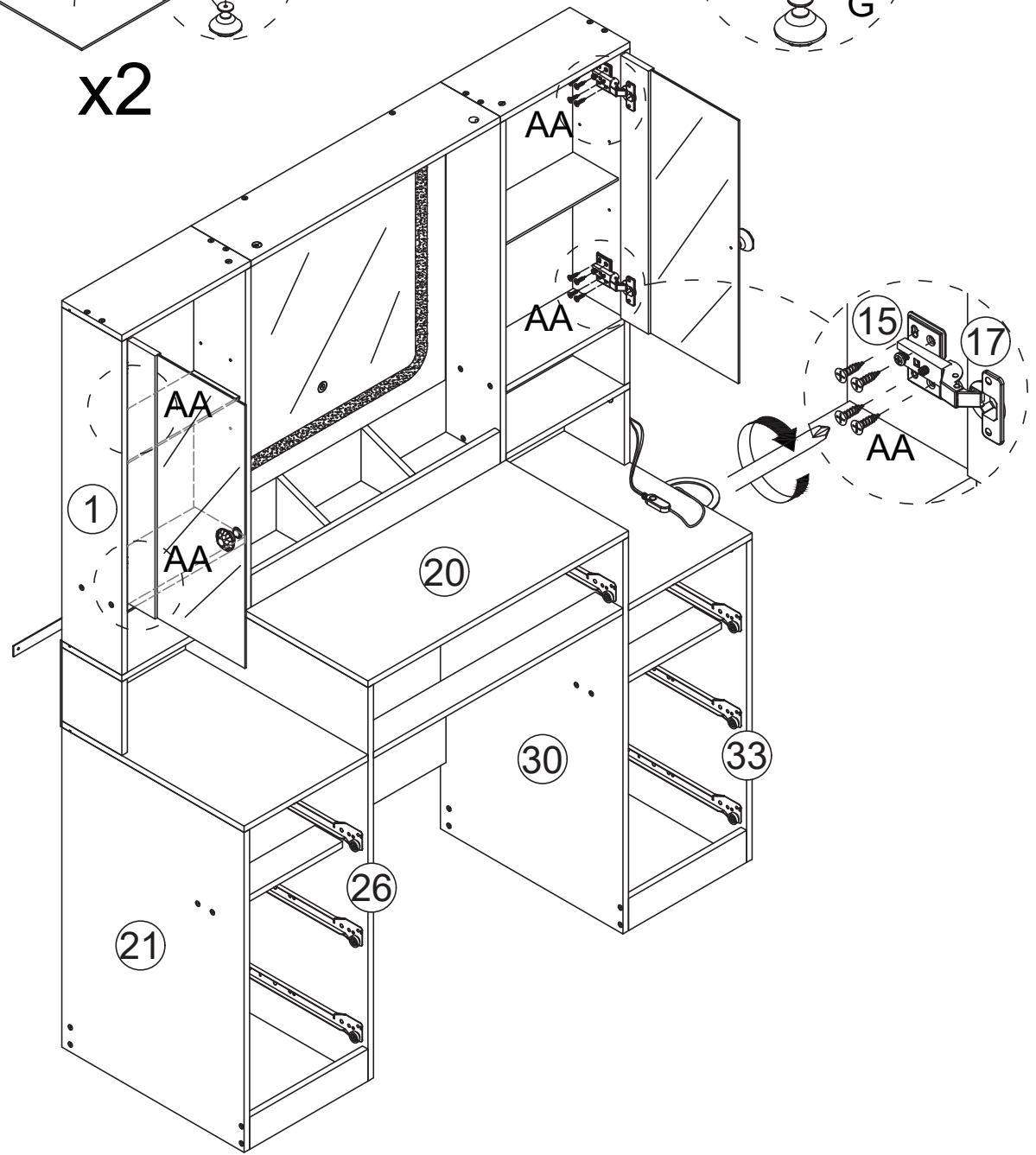
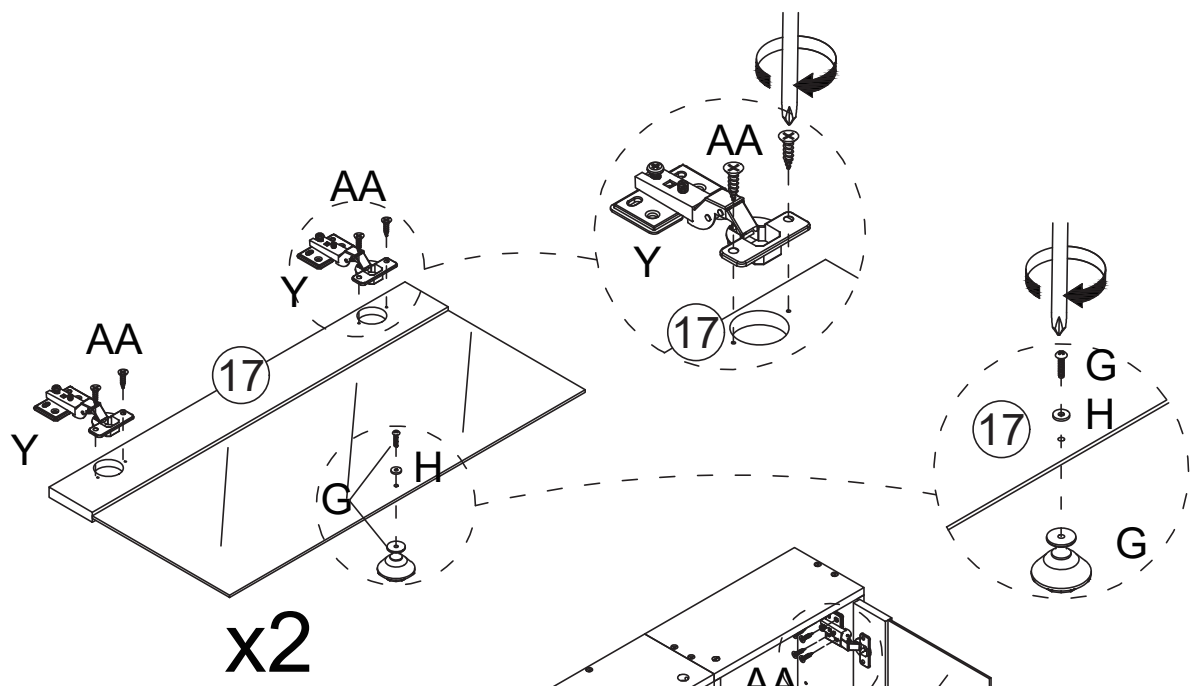
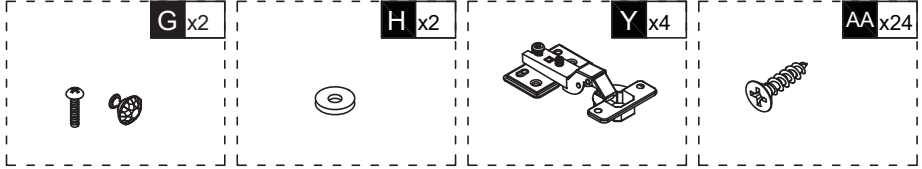

BB x66

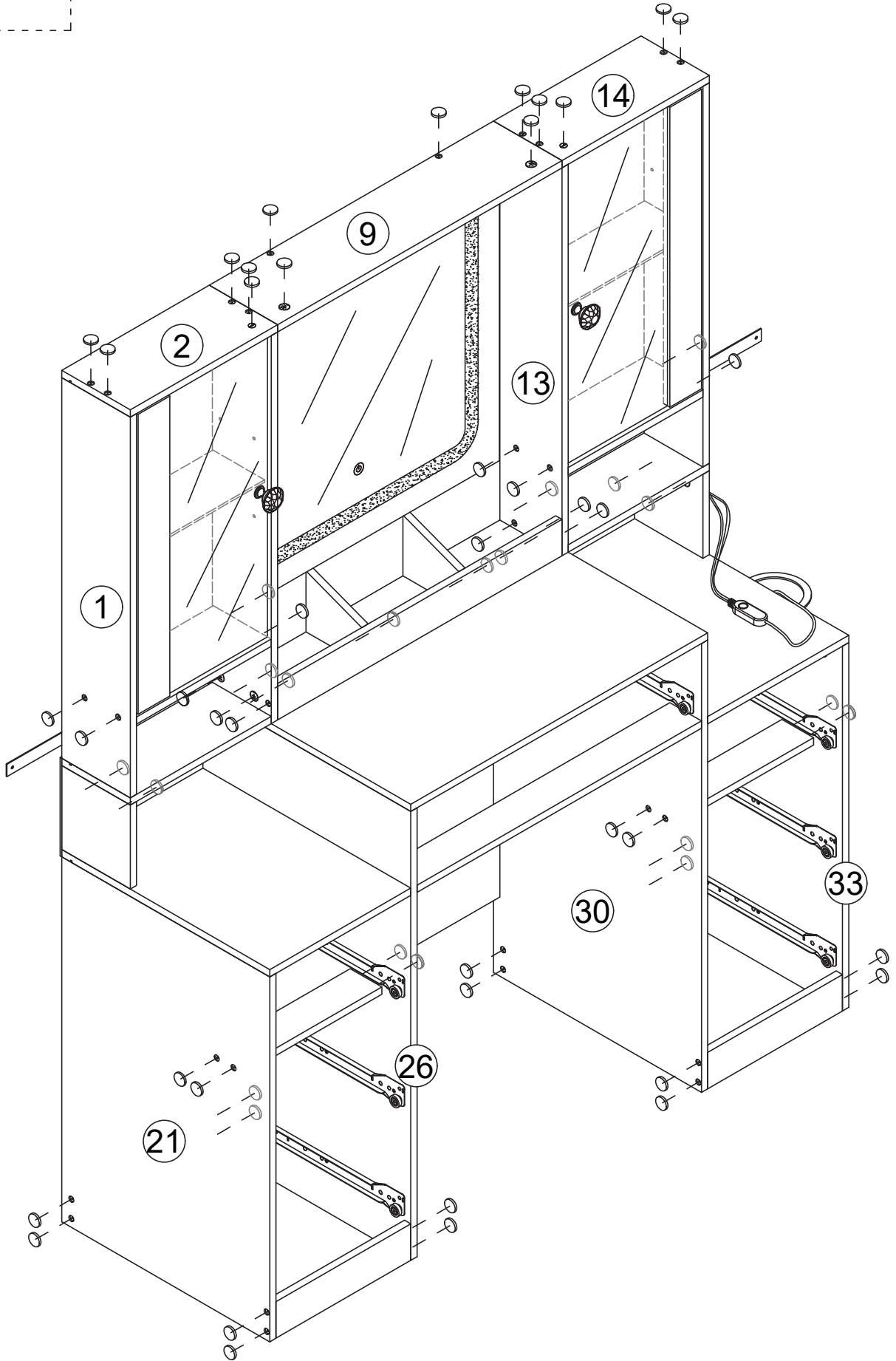

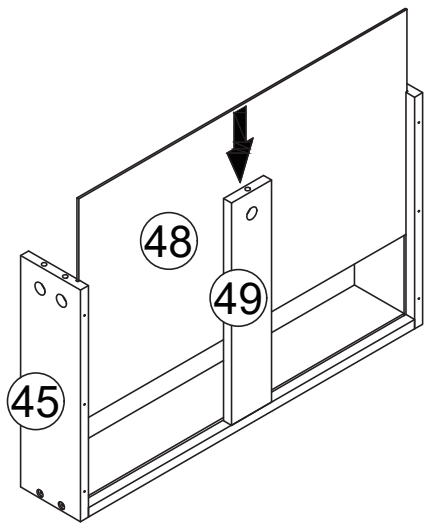
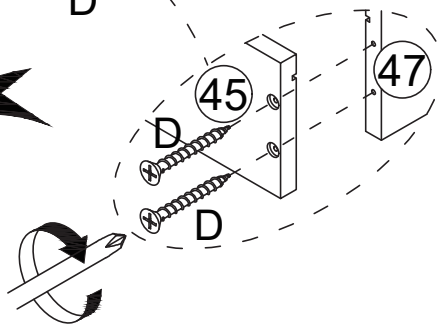
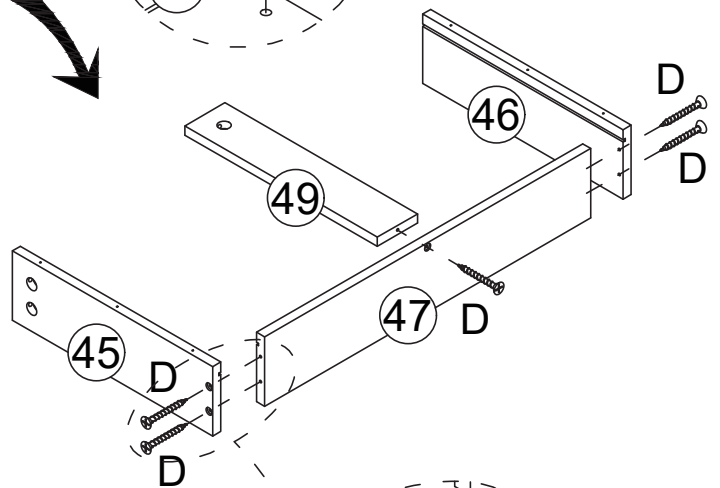
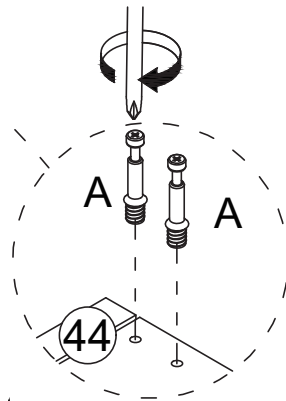
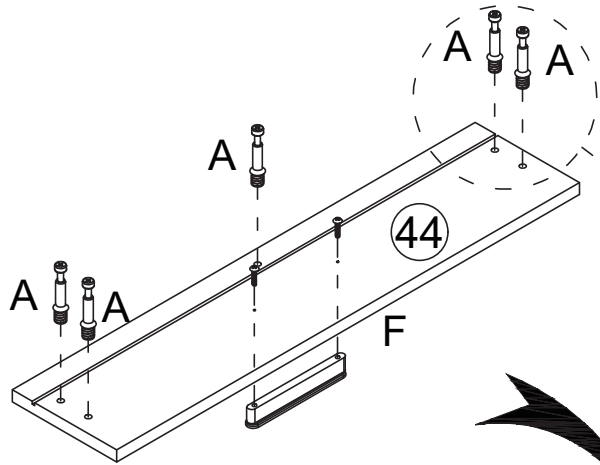
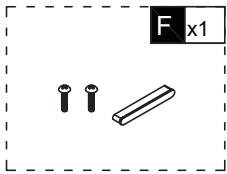
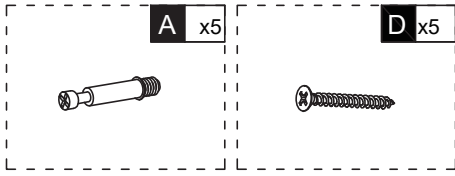

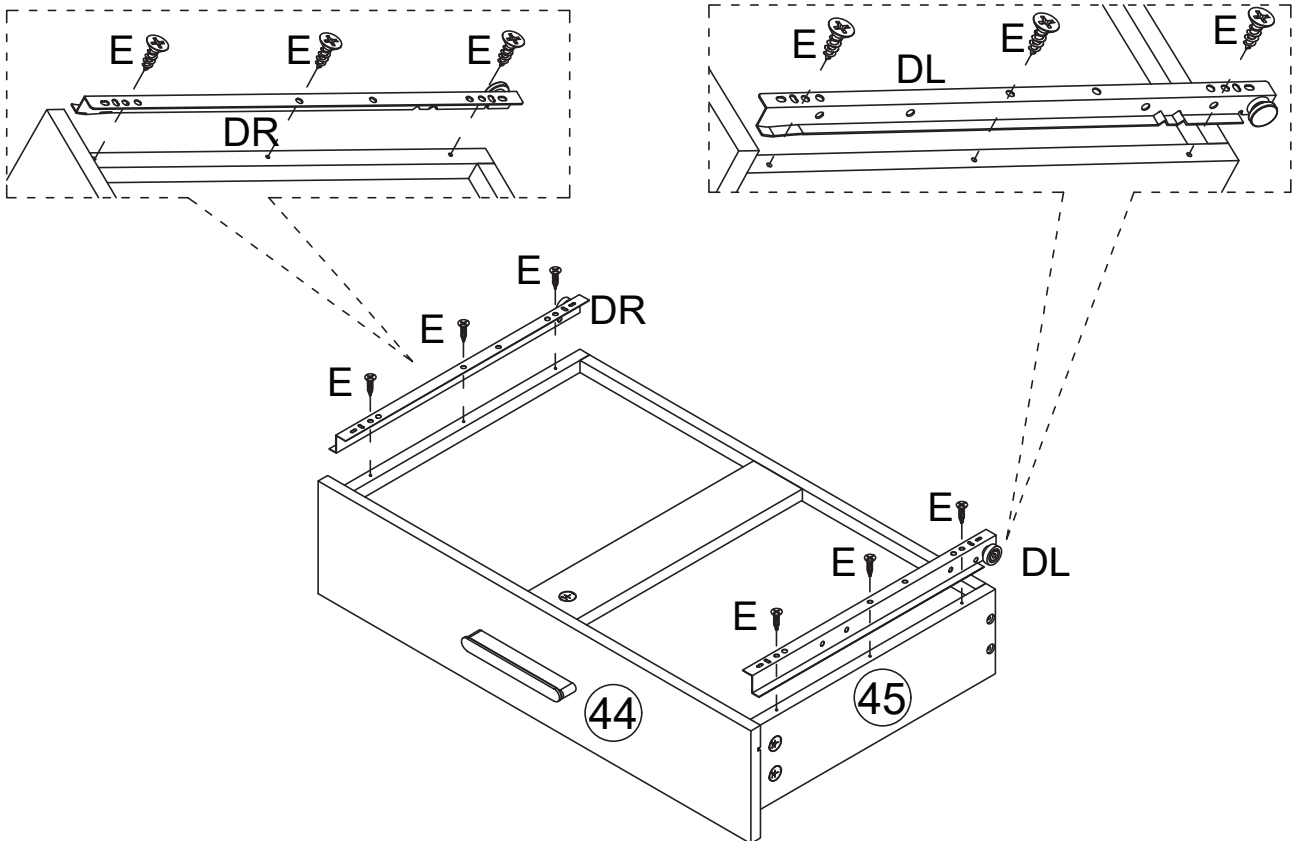
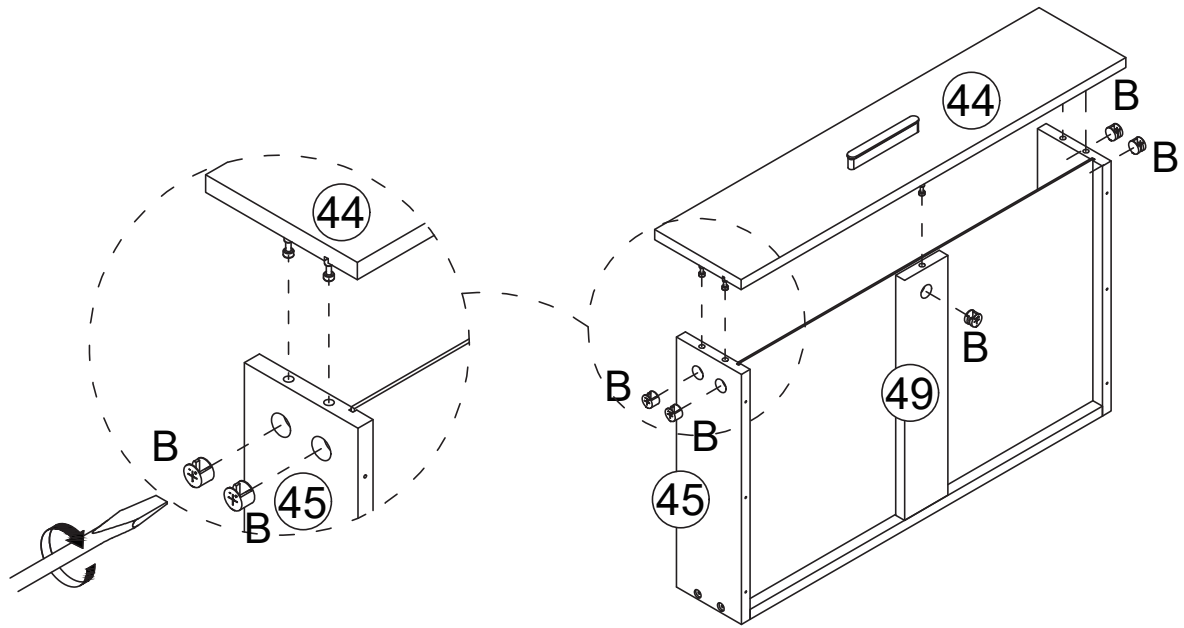
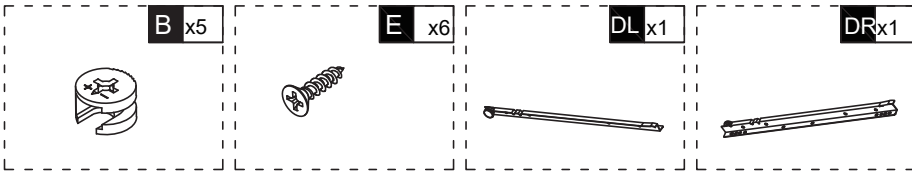

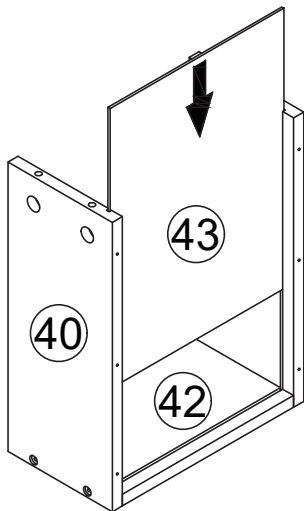
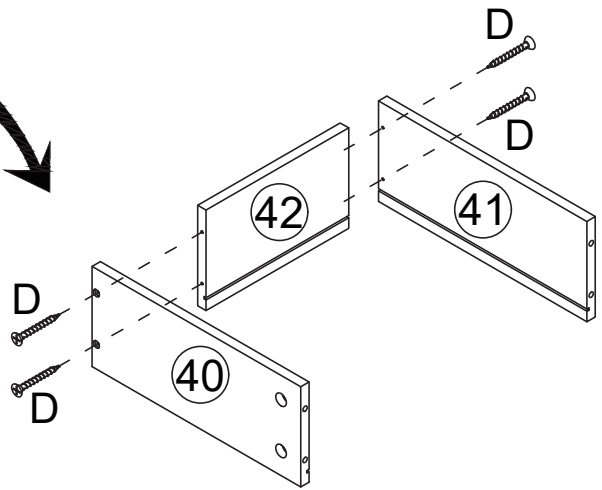
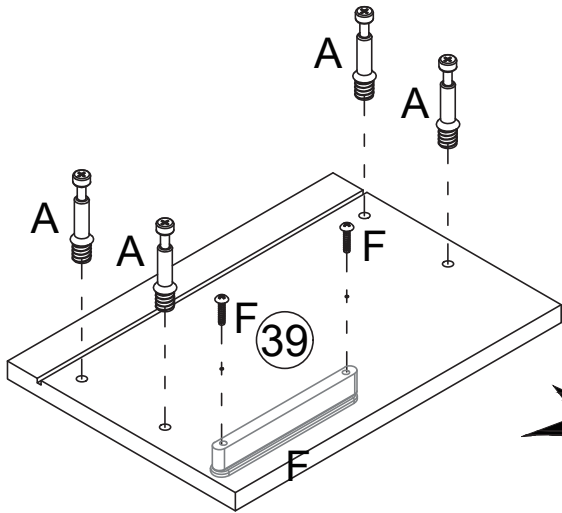
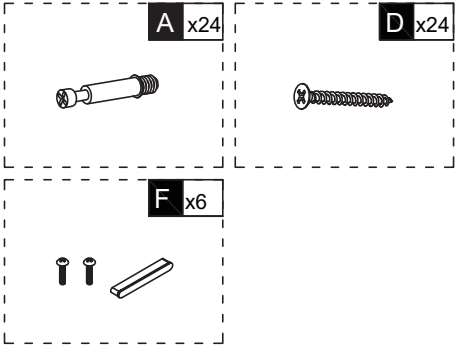

x6

B x24



E x36



DL x6



DRx6

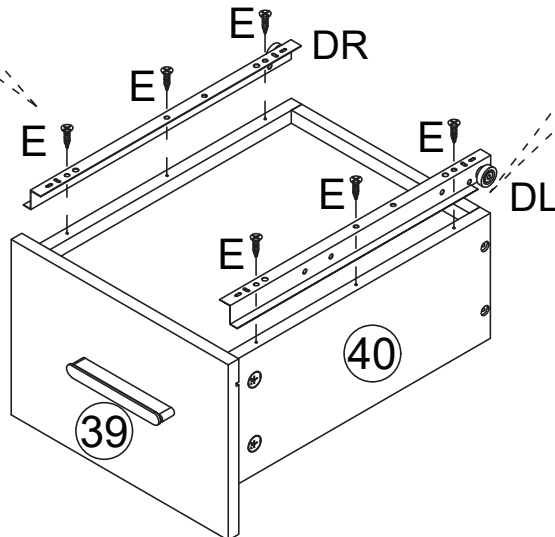
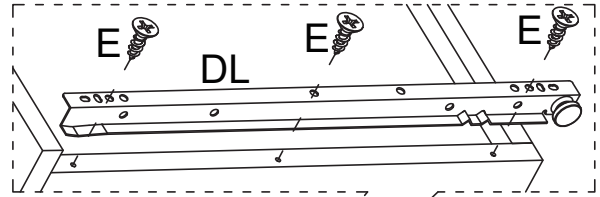
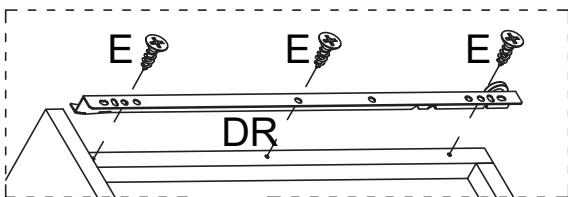
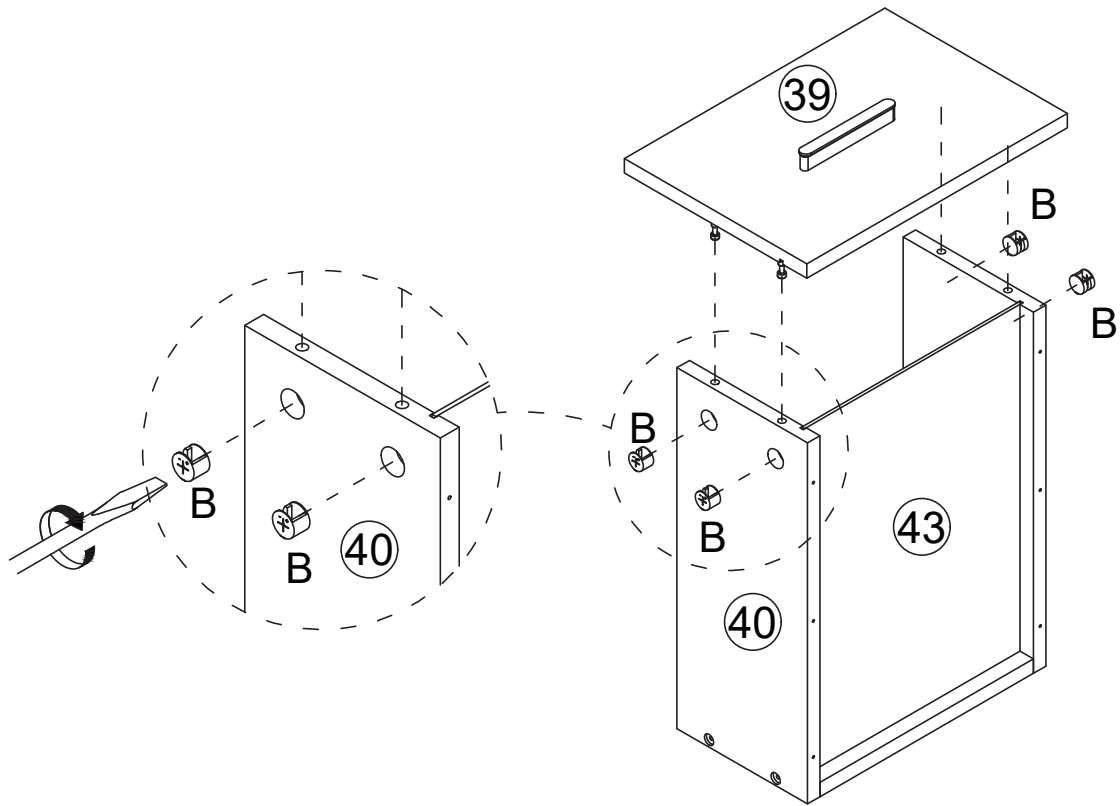

x6

DDx1



(1)

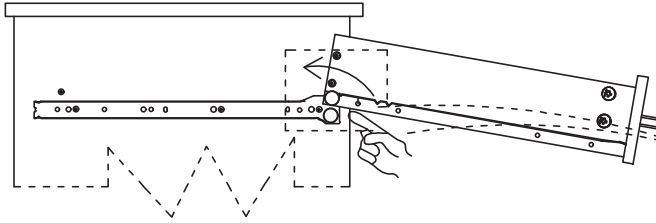

(2)

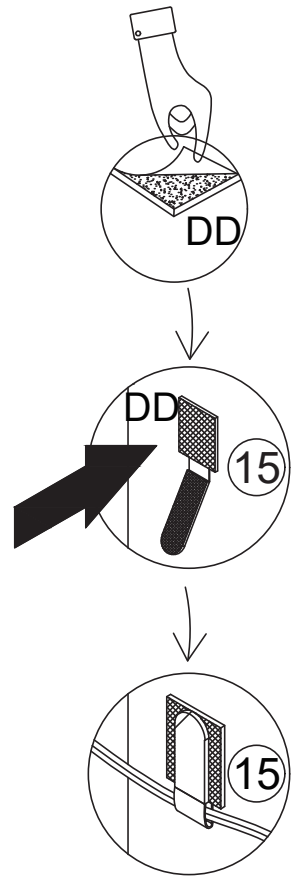
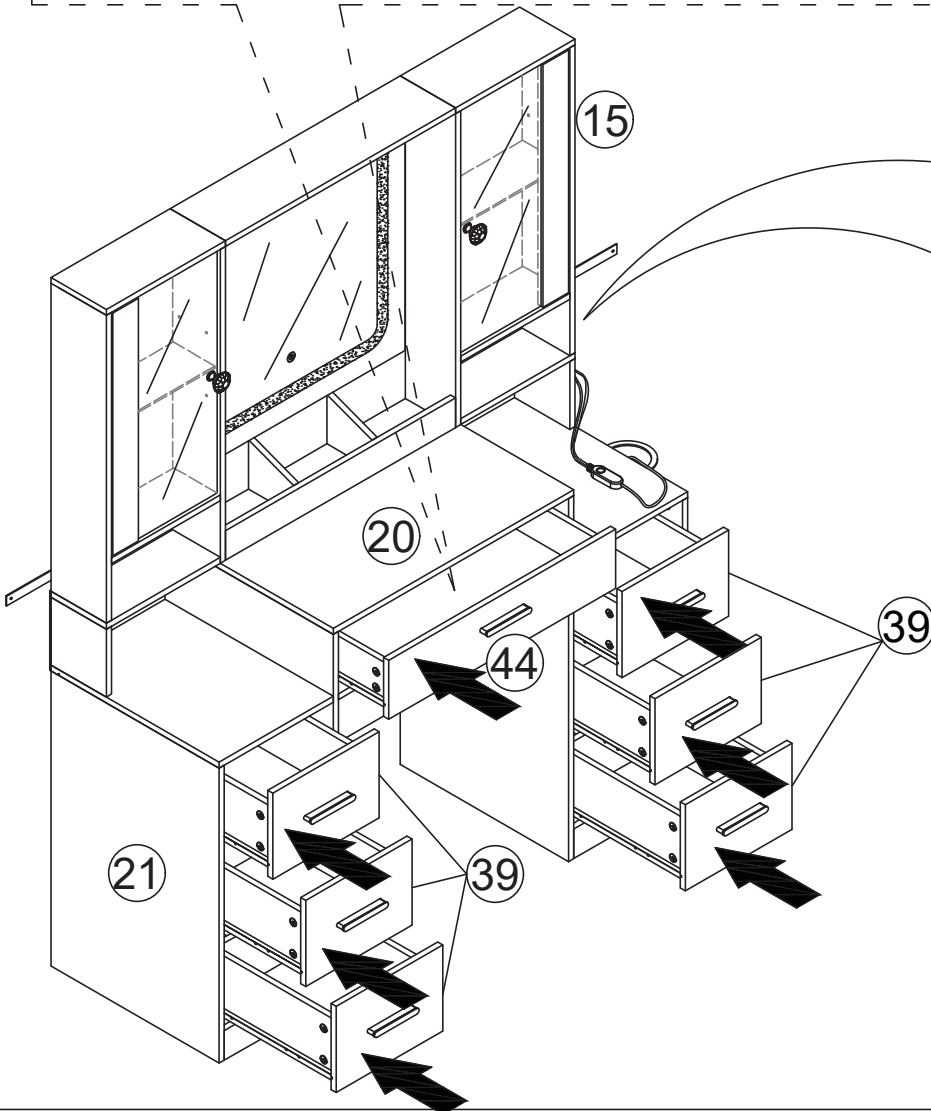
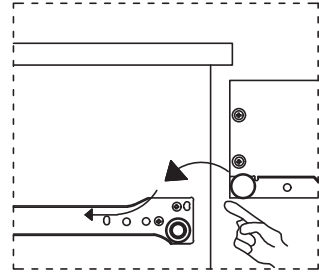
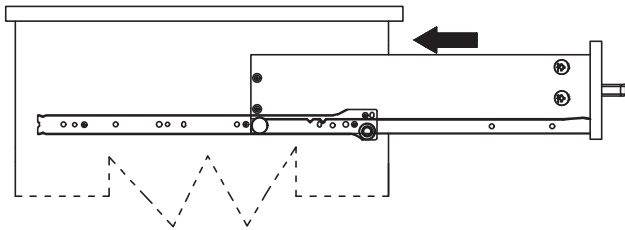

You are free to choose whether to install and where to install.

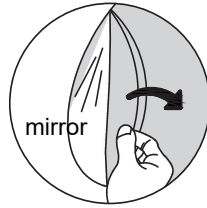
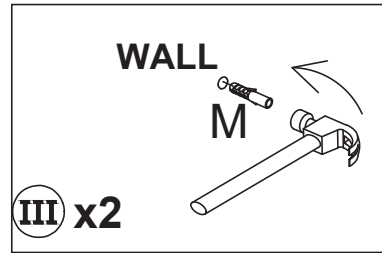
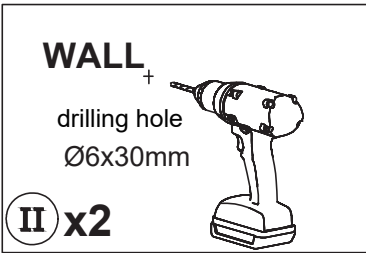
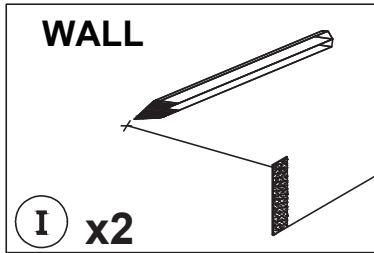
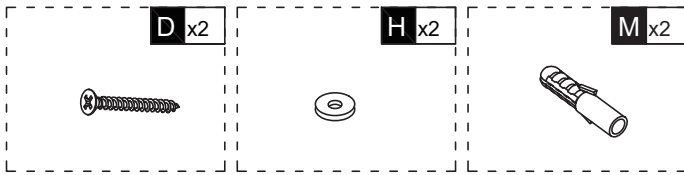

Please tear off the film on the outside of the mirror.

