









# Wood Cane Headboard

Queen  
King

Examine all packaging material for small parts that may have come loose during shipment. Periodic checks are recommended to insure that all components are in proper position, tight and free from damage. Keep this assembly instruction for future reference. Adult assembly is required.

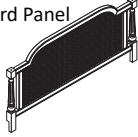
CODE	QTY	HARDWARE
1	4	1/4" x 3" Allen Bolts 
2	8	1/4" x 1-1/2" Allen Bolts 
3	4	Flat Washers 
4	4	Hex Nuts 
5	8	Ø10 x 40L m/m Wood Dowels 
6	1	Allen Wrench 

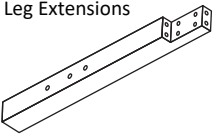
CODE	QTY	COMPONENTS	CODE	QTY	COMPONENTS
A	1	Headboard Panel 	B	2	Finials 
			C	2	Leg Extensions 

The Bed Frame  is not included. Sold separately.

**FIGURE 3**

**STEP 1 - Figure 1**

Begin assembly by attaching Leg Extensions (C) to Headboard Panel (A) using 4 Wood Dowels (5) and 4 Allen Bolts (2). Tighten bolts with Allen Wrench (6) provided.

**STEP 2 - Figure 2**

Attach bed frame (not included) to Leg Extensions (C) using 2 Allen Bolts (1) from behind and 2 Flat Washers (3) and 2 Hex Nuts (4) per leg. Tighten bolts with Allen Wrench (6) provided.

**STEP 3 - Figure 3**

Attach Finials (B) to Headboard Panel (A) by screwing them into place. The assembly is now complete.

**FIGURE 1**



**FIGURE 2**

**CARE & MAINTENANCE:** The touch of a soft cloth is all the maintenance the finish will ever need. Please do not use harsh or abrasive cleaners for polishing, as they may cause damage to the finish. Periodic checks are recommended to make sure that all hardware is securely tightened.

# Wood Cane Footboard

Queen  
King

Examine all packaging material for small parts that may have come loose during shipment. Periodic checks are recommended to insure that all components are in proper position, tight and free from damage. Keep this assembly instruction for future reference. Adult assembly is required. The product is designed for residential use only.

CODE	QTY	HARDWARE	
1	4	1/4" X 1" Allen Bolts	
2	4	1/4" Flat Washers	
3	1	Allen Wrench	

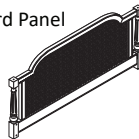
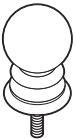
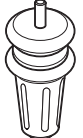
CODE	QTY	COMPONENTS	CODE	QTY	COMPONENTS
A	1	Footboard Panel 	B	2	Finials 
			C	2	Feet 

## ⚠ WARNING

- Do not let any sharp objects touch or rub the surface of the product.
- When assembling, do not let children play around the working area.
- Please confirm all parts are correct before starting the assembly process.
- Do not tighten all bolts and screws completely until the entire unit has been assembled and set up.
- Be careful if using power tools as they can over tighten screws and strip threads.

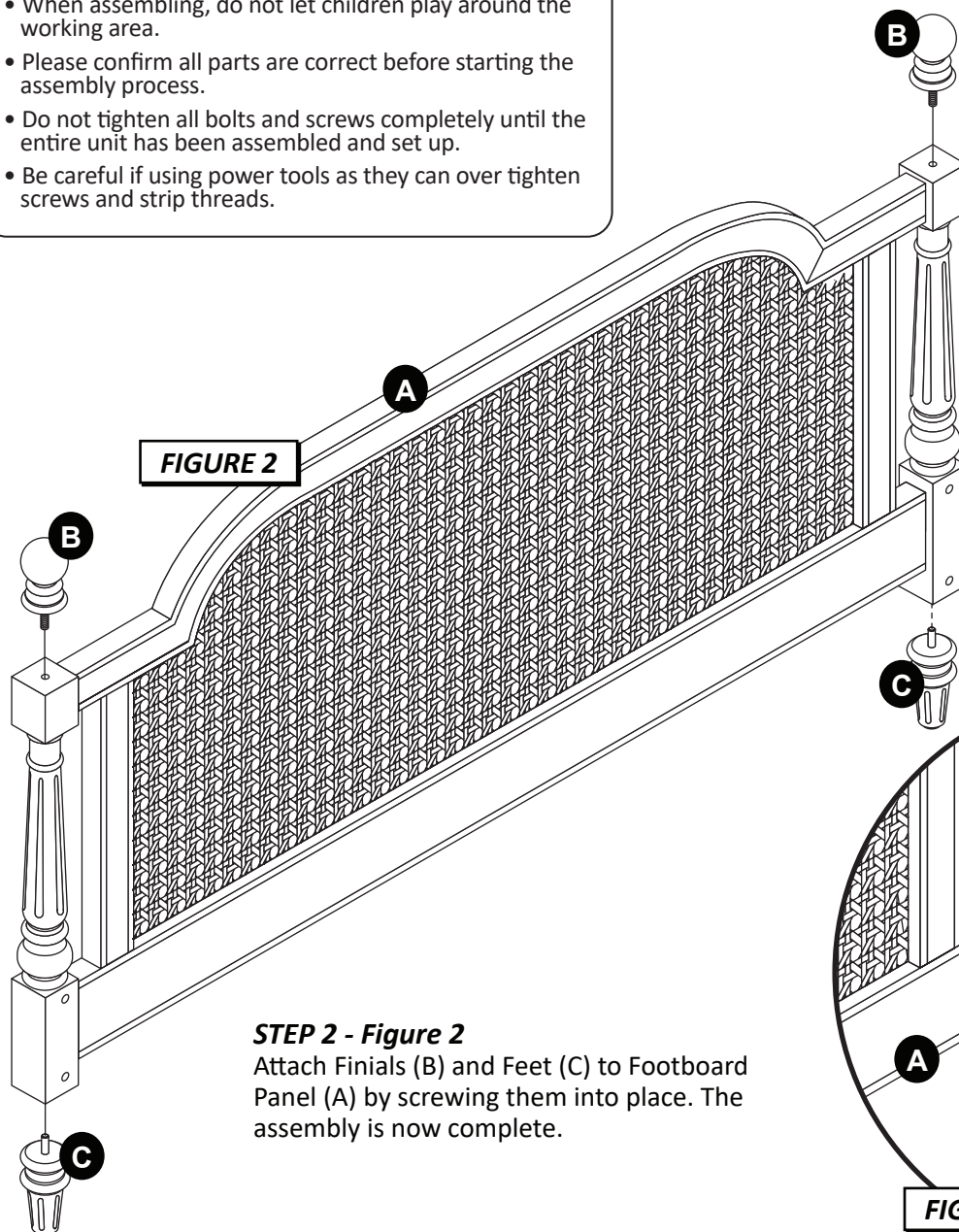

**FIGURE 2**

### STEP 2 - Figure 2

Attach Finials (B) and Feet (C) to Footboard Panel (A) by screwing them into place. The assembly is now complete.

### STEP 1 - Figure 1

Begin assembly by attaching bed frame (not included) to Footboard Panel (A) using 2 Allen Bolts (1) and 2 Flat Washers (2) per leg. Tighten bolts with Allen Wrench (3) provided.

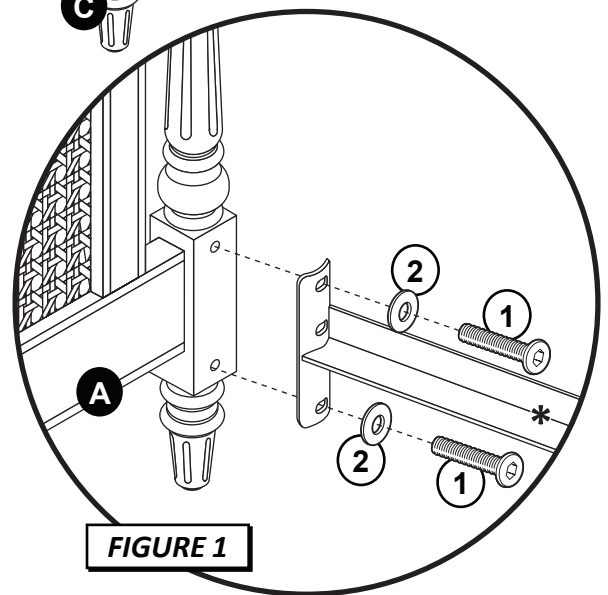

**FIGURE 1**

**CARE & MAINTENANCE:** The touch of a soft cloth is all the maintenance the finish will ever need. Please do not use harsh or abrasive cleaners for polishing, as they may cause damage to the finish. Periodic checks are recommended to make sure that all hardware is securely tightened.