

ASSEMBLY INSTRUCTIONS

TWIN LOW LOFT BED WITH DESK AND SHELVES

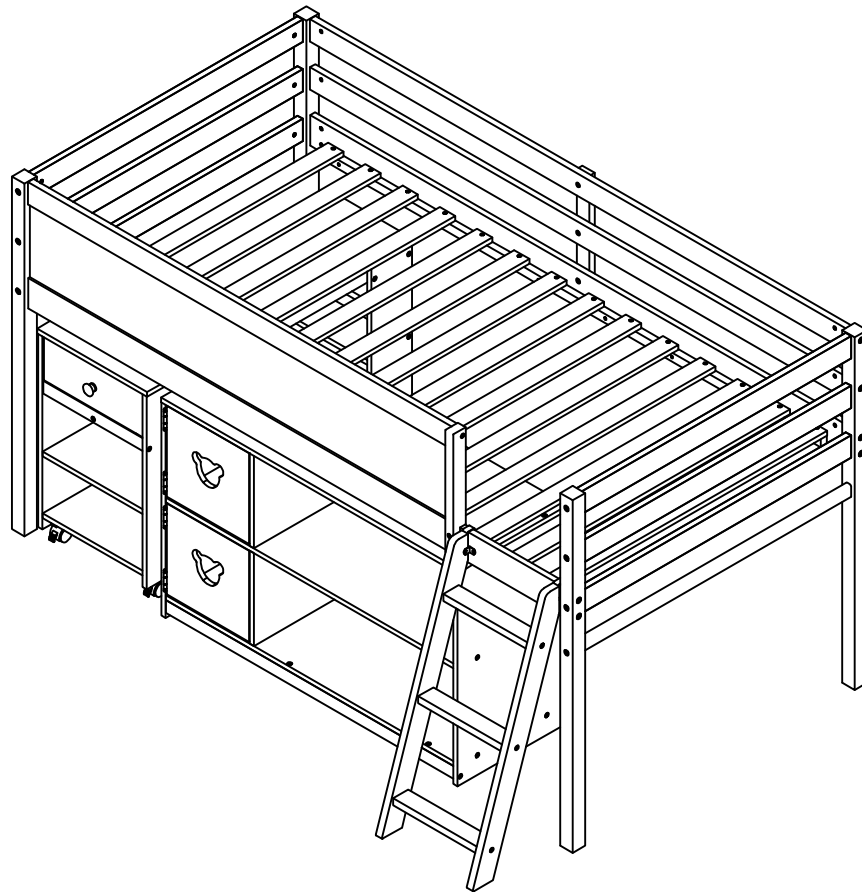

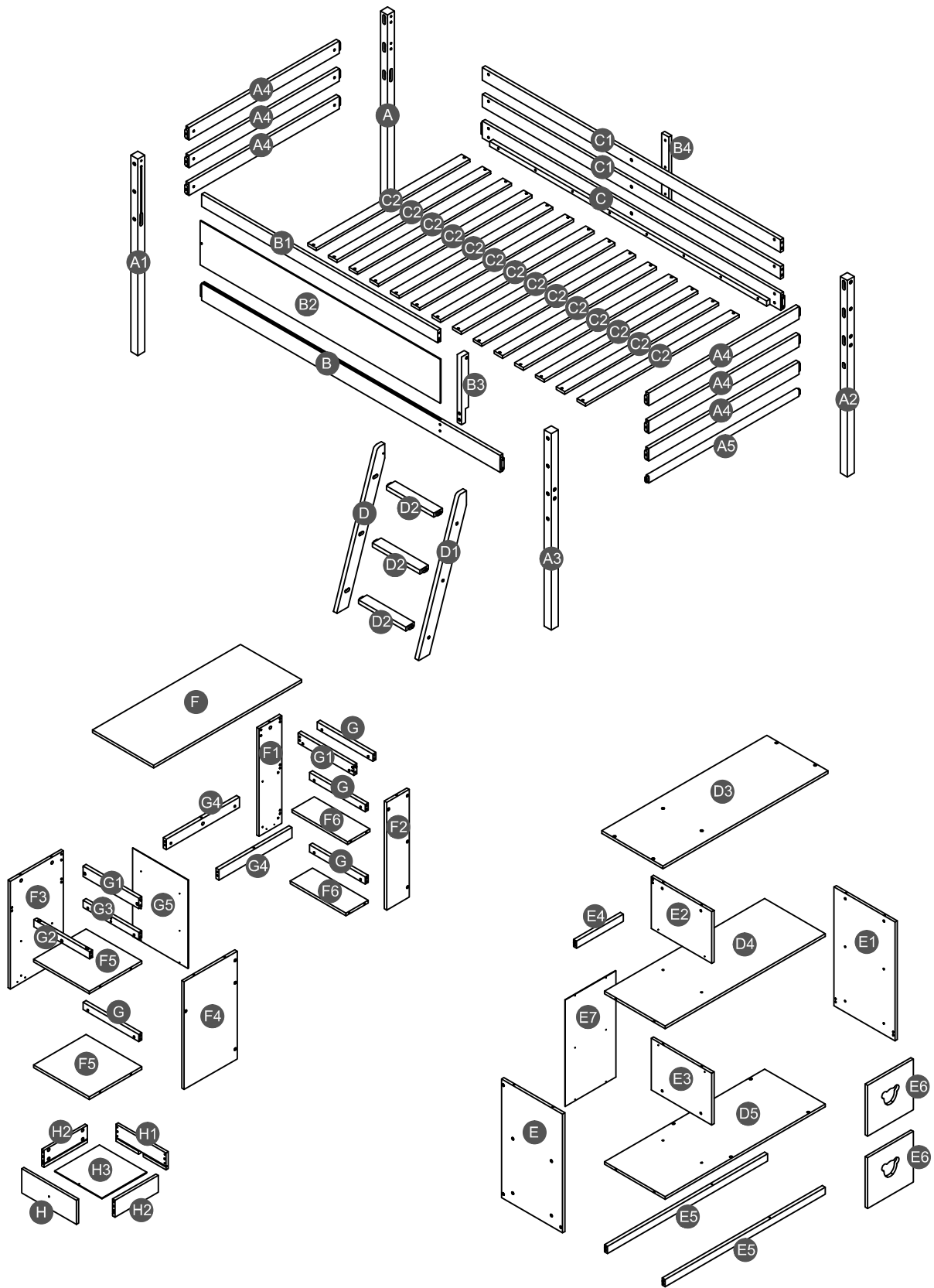





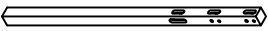
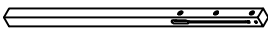
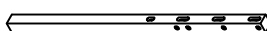
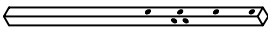
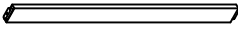
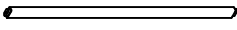
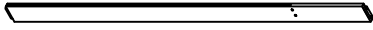
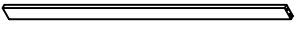
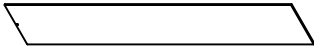
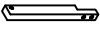

Detail View

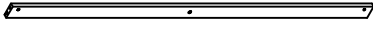

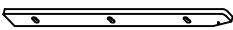
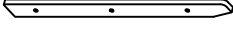

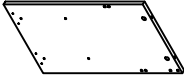
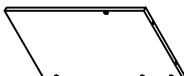

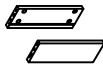



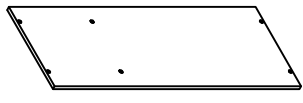
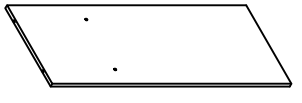
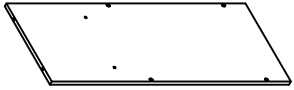
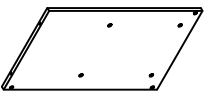

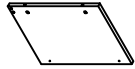
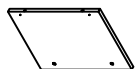
Part list & Hardware List

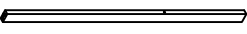

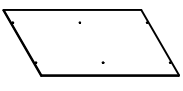
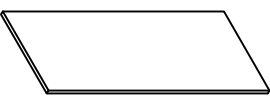
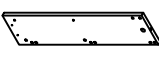
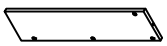
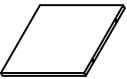
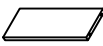

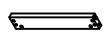

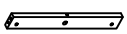
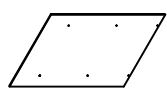
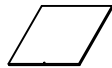



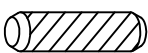
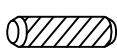
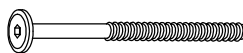
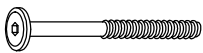
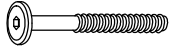

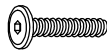





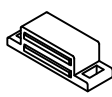



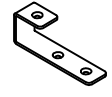

(1-2)

<p>A</p>  <p>Leg (Left Back) - 1pc</p>	<p>A1</p>  <p>Leg (Left Front) - 1pc</p>	<p>A2</p>  <p>Leg (Right Back) - 1pc</p>
<p>A3</p>  <p>Leg (Right Front) - 1pc</p>	<p>A4</p>  <p>Horizontal bar HB/FB - 6pcs</p>	<p>A5</p>  <p>Hanging bar - 1pc</p>
<p>B</p>  <p>Side rail (front) - 1pc</p>	<p>B1</p>  <p>Guard rail (front) - 1pc</p>	<p>B2</p>  <p>Side panel (front) - 1pc</p>
<p>B3</p>  <p>Vertical guard rail (right) - 1pc</p>	<p>C</p>  <p>Side rail (back) - 1pc</p>	<p>C1</p>  <p>Long guard rail (back) - 2pcs</p>
<p>C2</p>  <p>Slats - 14 pcs</p>	<p>D</p>  <p>Ladder (left) - 1pc</p>	<p>D1</p>  <p>Ladder (right) - 1pc</p>
<p>D2</p>  <p>Step ladder - 3pcs</p>	<p>F3</p>  <p>Side panel (left) - 1pc</p>	<p>F4</p>  <p>Side panel (right) - 1pc</p>
<p>H</p>  <p>Front drawer panel - 1pc</p>	<p>H1</p>  <p>Back drawer panel - 1pc</p>	<p>H2</p>  <p>Left / right drawer panel - 2pcs</p>

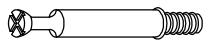
Part list (2-2)

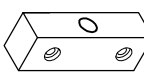

<p>B4</p>  <p>Vertical guard rail (back) - 1pc</p>	<p>D3</p>  <p>Top panel - 1pc</p>	<p>D4</p>  <p>Shelf panel - 1pc</p>
<p>D5</p>  <p>Bottom panel - 1pc</p>	<p>E</p>  <p>Side panel (left) - 1pc</p>	<p>E1</p>  <p>Side panel (right) - 1pc</p>
<p>E2</p>  <p>Upper divider panel - 1pc</p>	<p>E3</p>  <p>Lower divider panel - 1pc</p>	<p>E4</p>  <p>Upper horizontal bar (back) - 1pc</p>
<p>E5</p>  <p>Lower horizontal bar - 2pcs</p>	<p>E6</p>  <p>Door - 2pcs</p>	<p>E7</p>  <p>Back panel - 1pc</p>
<p>F</p>  <p>Top panel - 1pc</p>	<p>F1</p>  <p>Side panel (left) - 1pc</p>	<p>F2</p>  <p>Side panel (right) - 1pc</p>
<p>F5</p>  <p>Shelf panel - 2pcs</p>	<p>F6</p>  <p>Shelf panel - 2pcs</p>	<p>G</p>  <p>Horizontal bar - 4pcs</p>
<p>G1</p>  <p>Horizontal bar - 2pcs</p>	<p>G2</p>  <p>Horizontal bar (front) - 1pc</p>	<p>G3</p>  <p>Horizontal bar (back) - 1pc</p>
<p>G4</p>  <p>Horizontal bar - 2pcs</p>	<p>G5</p>  <p>Back panel - 1pc</p>	<p>H3</p>  <p>Drawer bottom - 1pc</p>

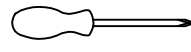
Hardware List (1-2)

<p>1</p>  <p>Ø10*40mm Wood dowel (6pcs)</p>	<p>2</p>  <p>Ø8*30mm Wood dowel (28pcs)</p>	<p>3</p>  <p>(Ø15)1/4"*100mm Hex-Head bolts (13pcs)</p>
<p>4</p>  <p>(Ø15)1/4"*80mm Hex-Head bolts (15pcs)</p>	<p>5</p>  <p>(Ø12)1/4"*60mm Hex-Head bolts (50pcs)</p>	<p>6</p>  <p>(Ø12)1/4"*35mm Hex-Head bolts (2pcs)</p>
<p>7</p>  <p>(Ø12)1/4"*30mm Hex-Head bolts (3pcs)</p>	<p>8</p>  <p>1/4"*15 (9.5mm) Horizontal-Hole bolts(78pcs)</p>	<p>9</p>  <p>(Ø12)1/4"*40mm Hex-Head bolts (4pcs)</p>
<p>10</p>  <p>Ø4*30mm Wood screws (40pcs)</p>	<p>11</p>  <p>Ø3.5*15mm Wood screws (43pcs)</p>	<p>12</p>  <p>Ø3.5*15mm Wood screws (12pcs)</p>
<p>13</p>  <p>66*39*28mm (135°) Hinges (4pcs)</p>	<p>14</p>  <p>45*17*13mm Door catch (2pcs)</p>	<p>15</p>  <p>42*12*1mm Metal magnet (2pcs)</p>
<p>16</p>  <p>Ø38*31mm Pine Knob (1pc)</p>	<p>17</p>  <p>3/16"*25mm Ph zinc(Knob) (1pc)</p>	<p>18</p>  <p>295*30mm Upper slider drawer (1pc)</p>
<p>19</p>  <p>313*58*28 mm Lower slider drawer (1pc)</p>	<p>20</p>  <p>81*26*21*(2.5mm) Hooks (2pcs)</p>	<p>21</p>  <p>17*21*21*2mm Metal bracket (6pcs)</p>
<p>22</p>  <p>64*52*95mm Castor (2pcs)</p>	<p>23</p>  <p>64*52*95mm Castor (4pcs)</p>	<p>24</p>  <p>Ø7"*35mm Cam lock (28pcs)</p>
<p>25</p>  <p>Ø14*9mm Cam lock (28pcs)</p>	<p>26</p>  <p>L80*35*19mm Support bar (6pcs)</p>	<p>27</p>  <p>Ø4*20mm Wood screws (10pcs)</p>
<p>28</p>  <p>(1/4")4.5*58mm Allen key (1pc)</p>	<div style="display: flex; align-items: center;">  <div style="border: 1px solid black; padding: 5px; width: 100%;"> <p style="margin: 0;">ASSEMBLY TOOLS REQUIRED (NOT INCLUDED)</p> <p style="margin: 0;">  (Phillip head screwdriver) </p> </div> </div> <p style="margin-top: 10px; font-size: small;">PLEASE BE CAREFUL DO NOT DAMAGE THE HOLE POSITION WHEN YOU USE POWER TOOLS !</p>	

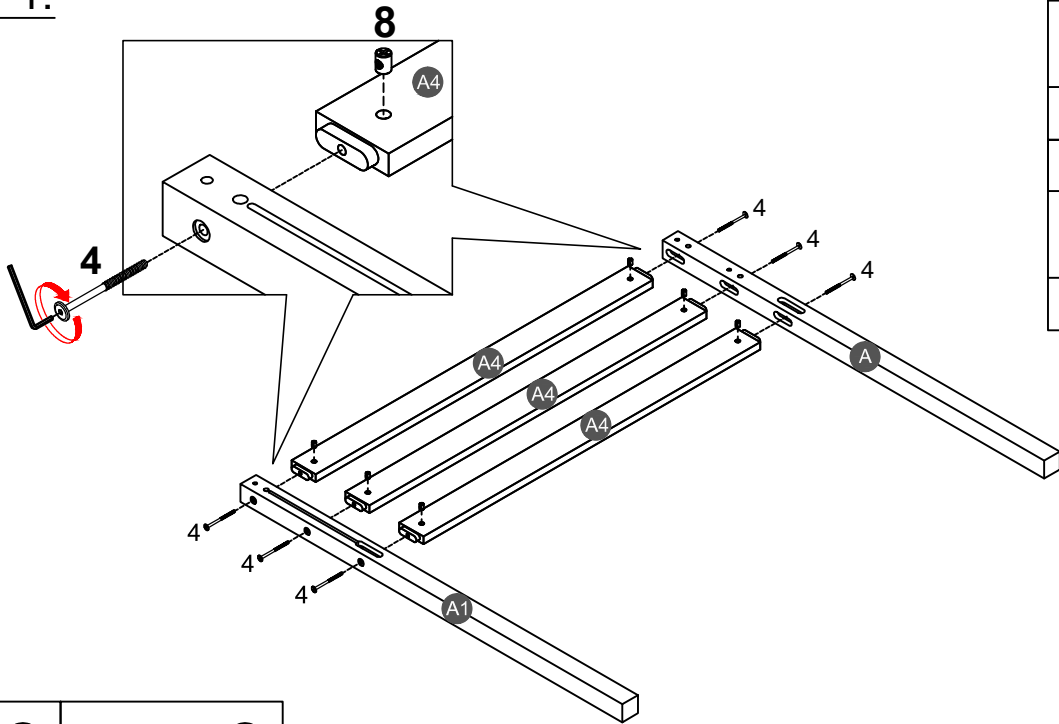
STEP 1:



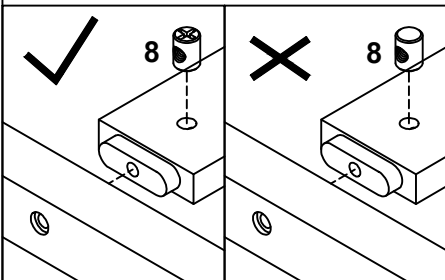

4	
6PCS	
8	
6PCS	



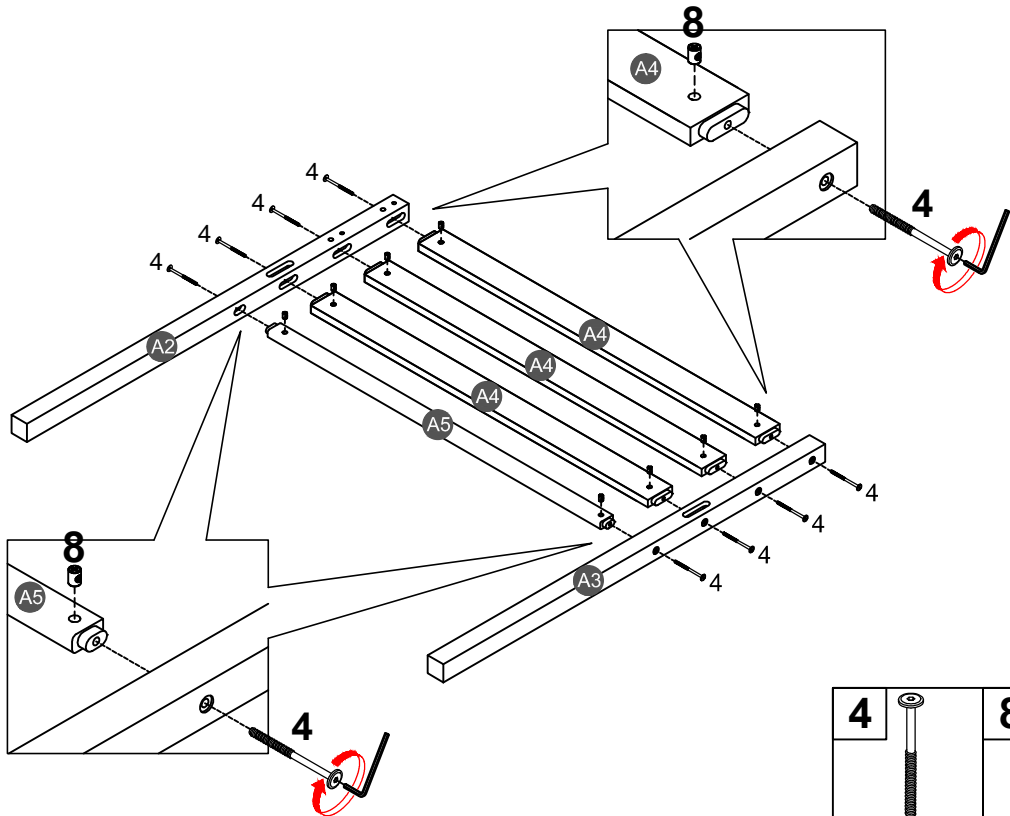

Note: Part 8 will face up with the "x" mark on it, otherwise it cannot be tightened

STEP 2:



4		8	
8PCS		8PCS	

STEP 3:

1 	3 	8 
4PCS	12PCS	12PCS

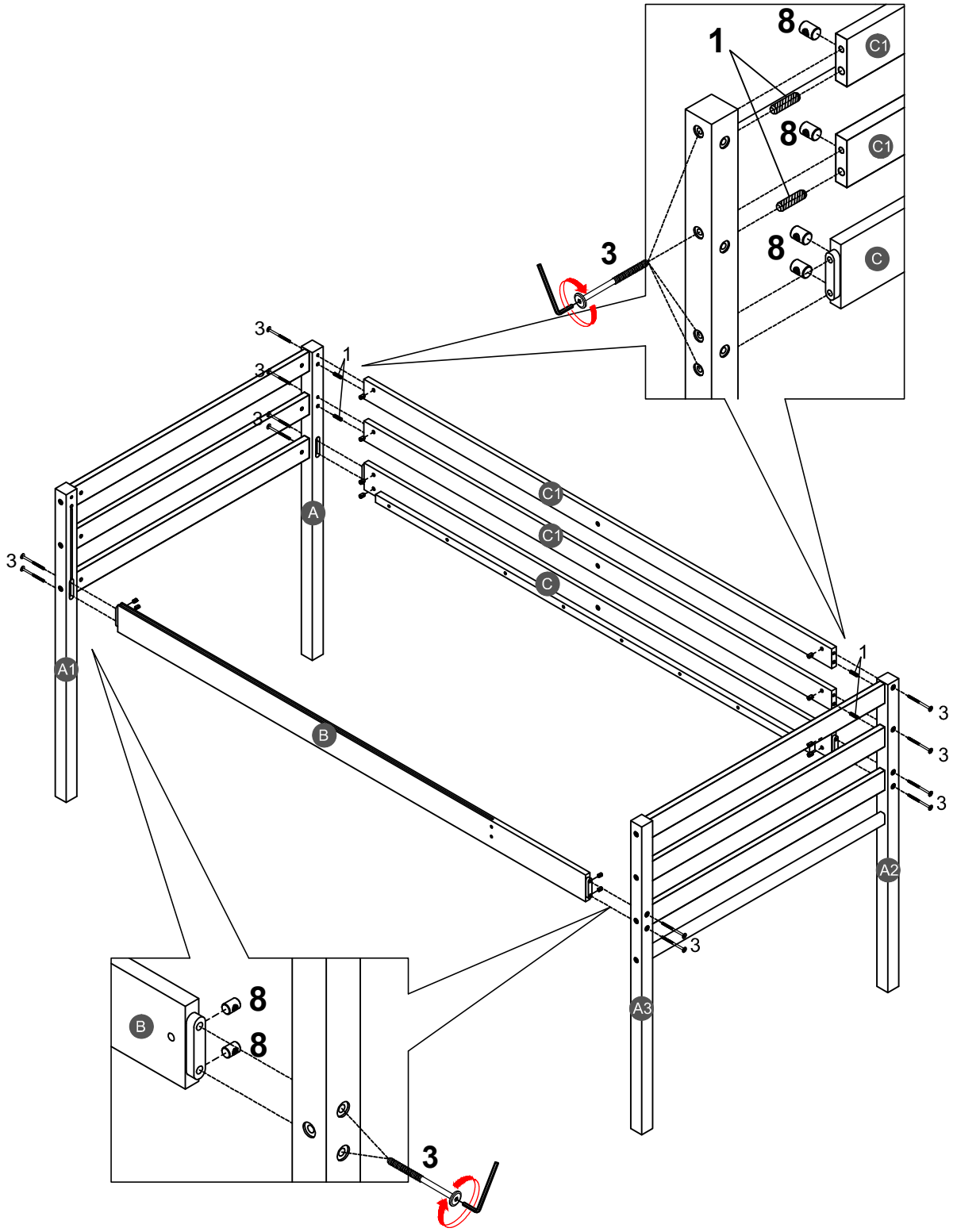

STEP 4:





7

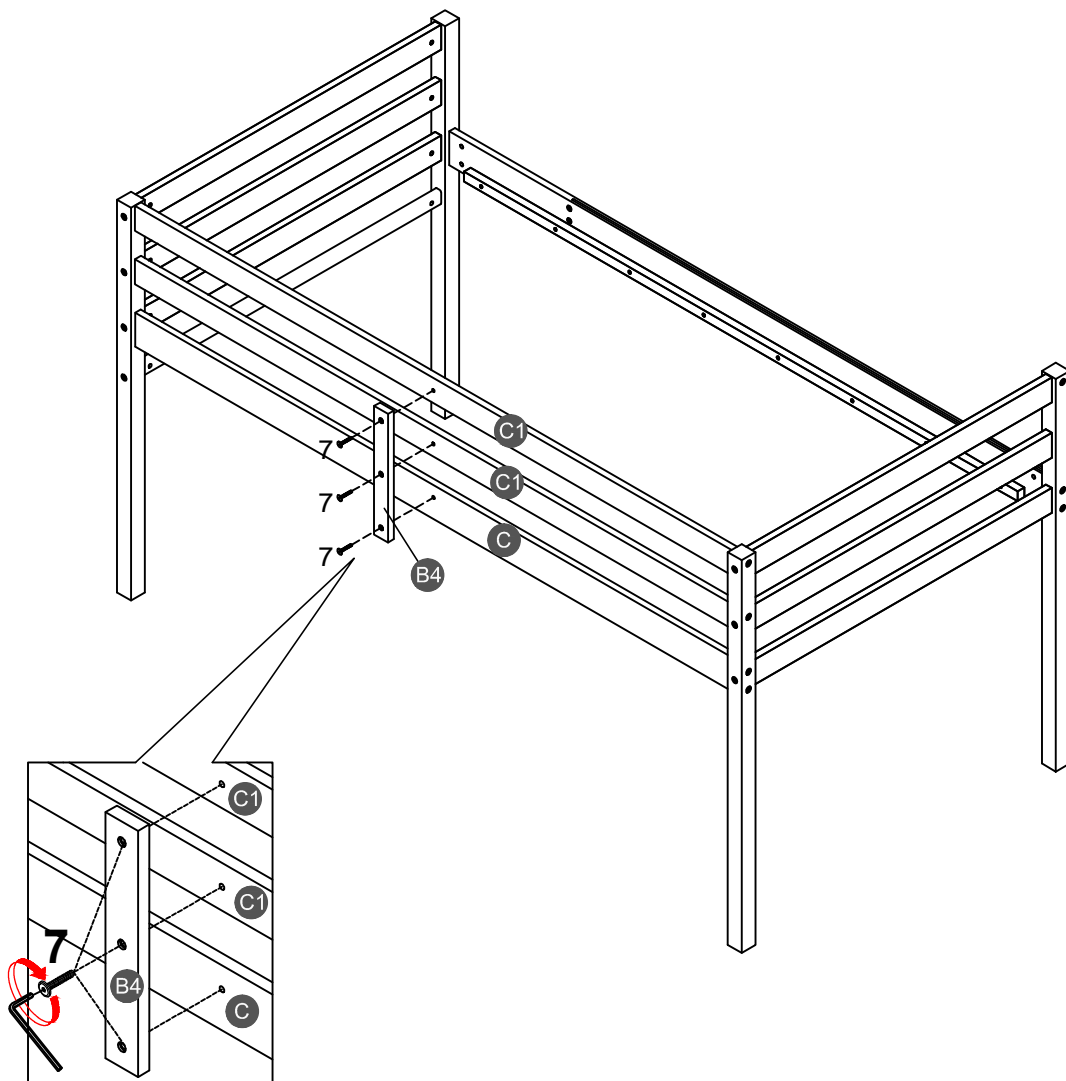

3PCS





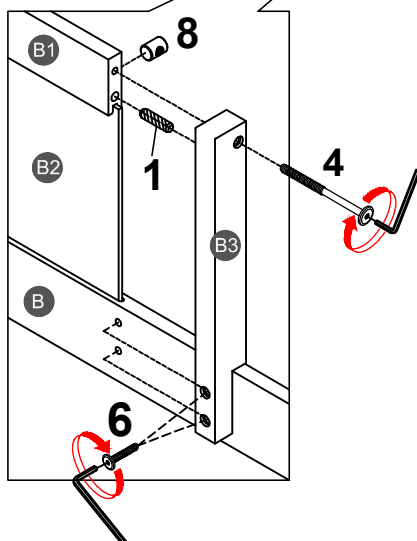
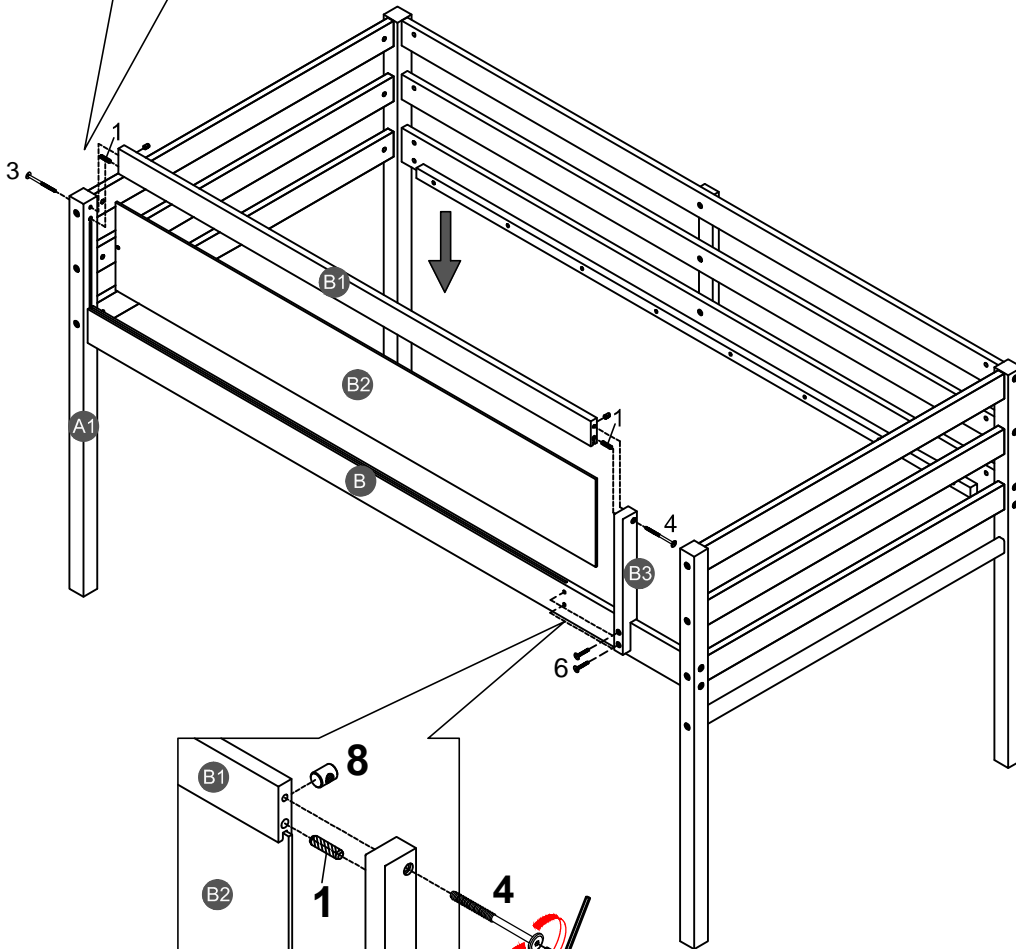
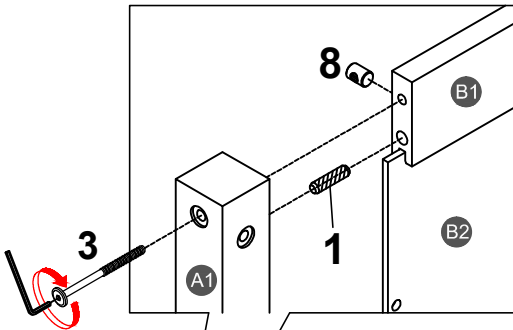

STEP 5:

1		3		4		6		8	
2PCS		1PC		1PC		2PCS		2PCS	



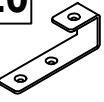

STEP 6:

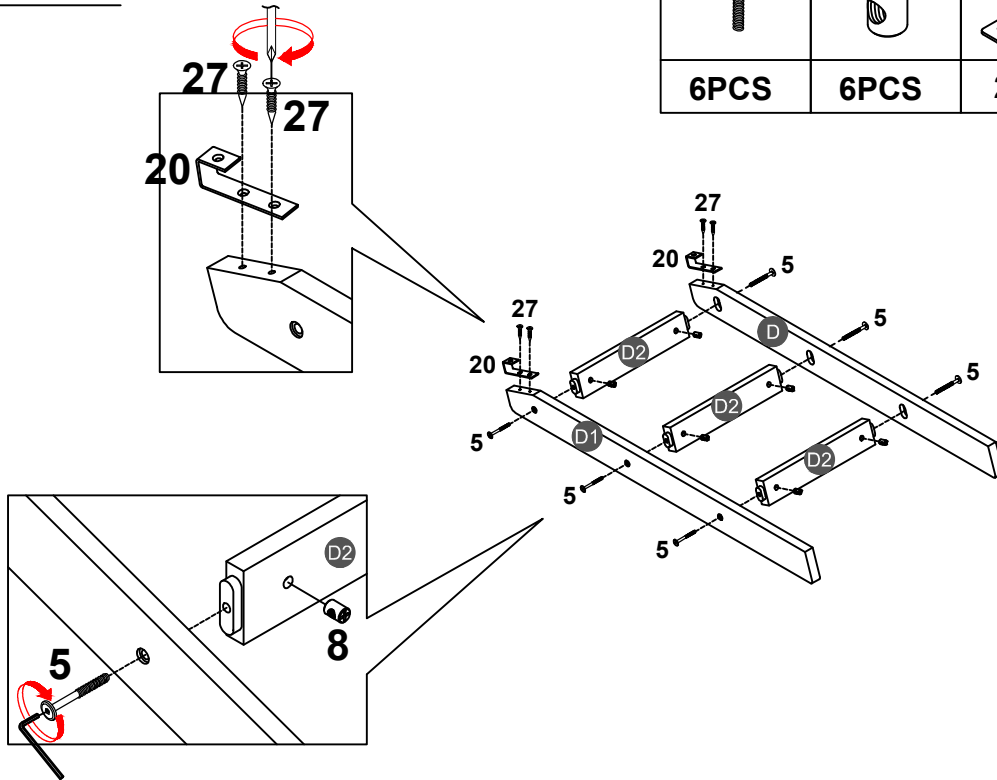
5		8		20		27	
6PCS		6PCS		2PCS		4PCS	



STEP 7:

21		27	
2PCS		6PCS	

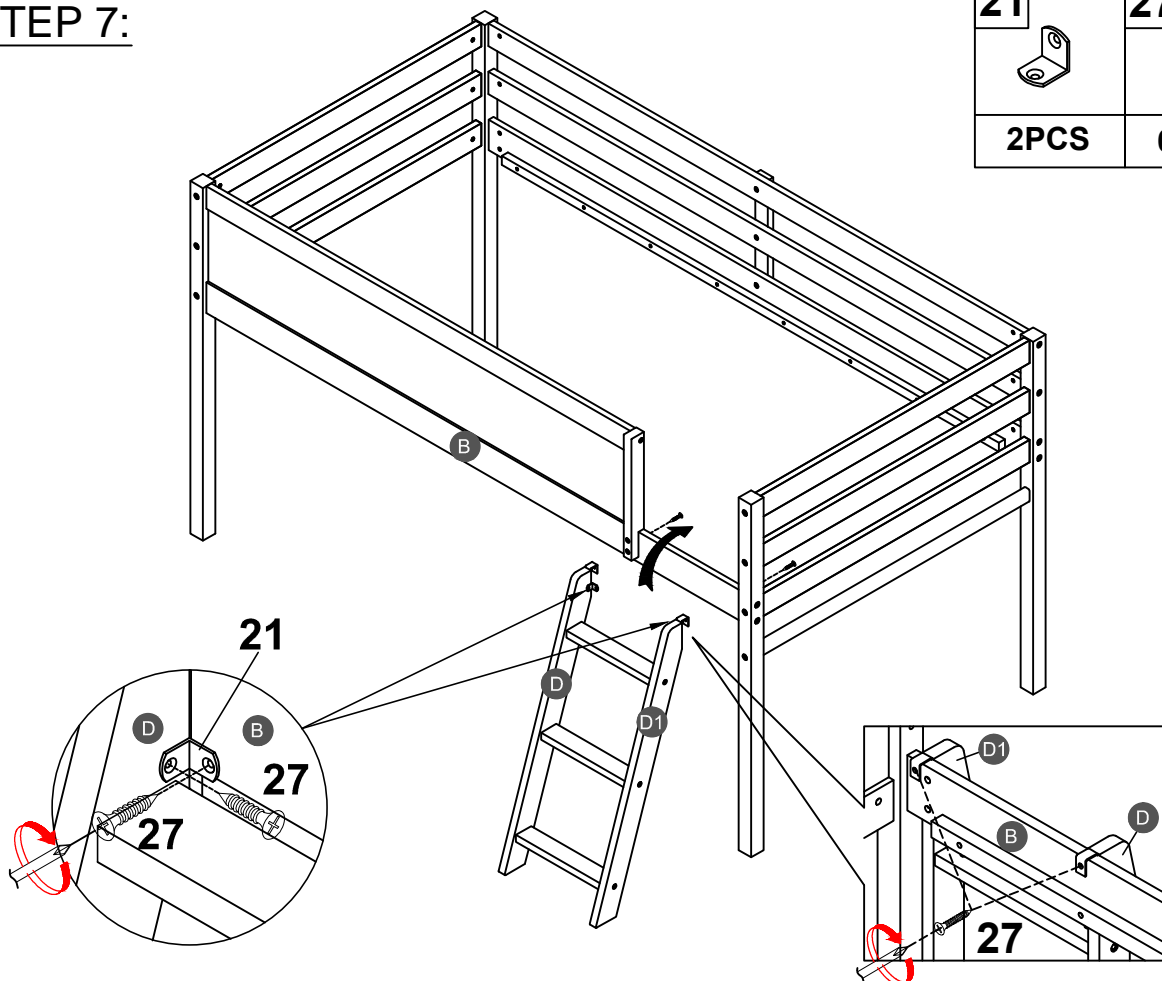

STEP 8:

10



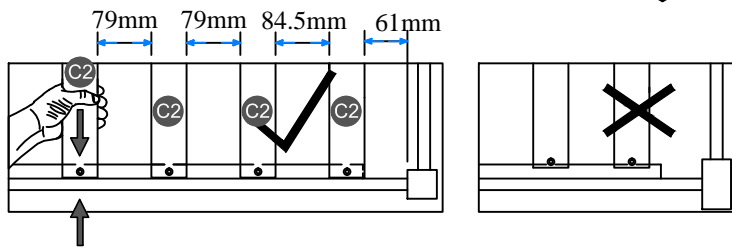
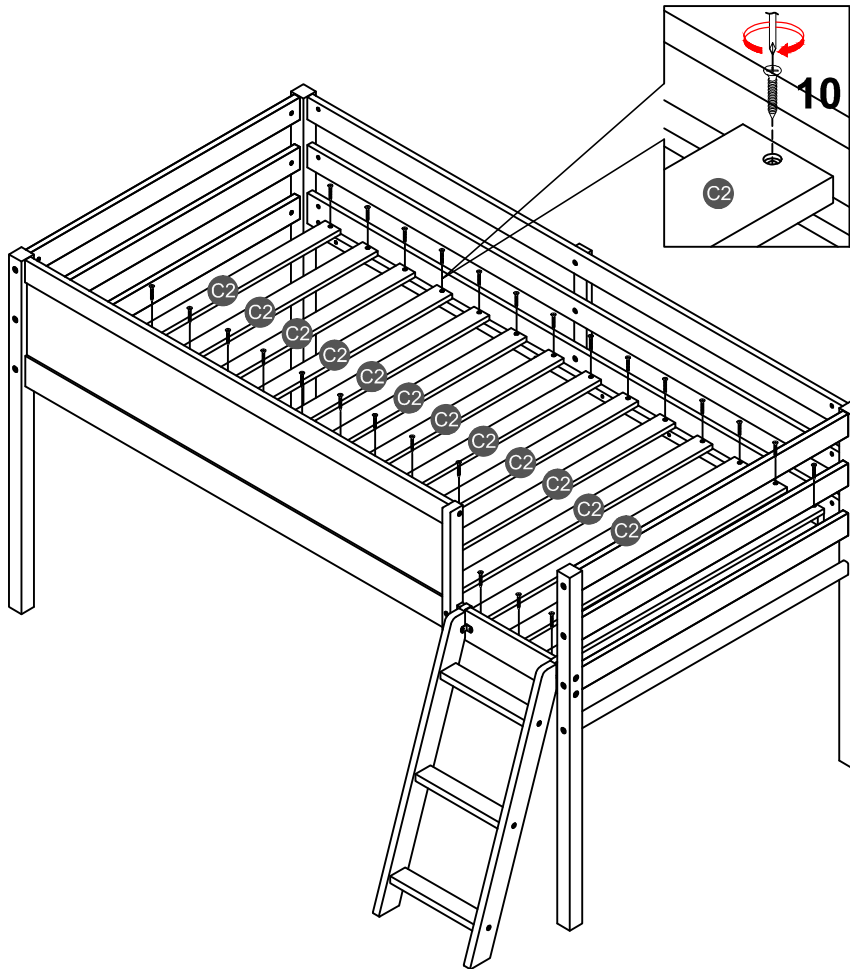

28PCS



NOTE: Please make sure the bed slats close to the side rail before locking the screws to avoid breakage. This step is required for both the left and right sides. Moreover, please do not lock the screws of the bed slats at the outermost edge to avoid damaging.

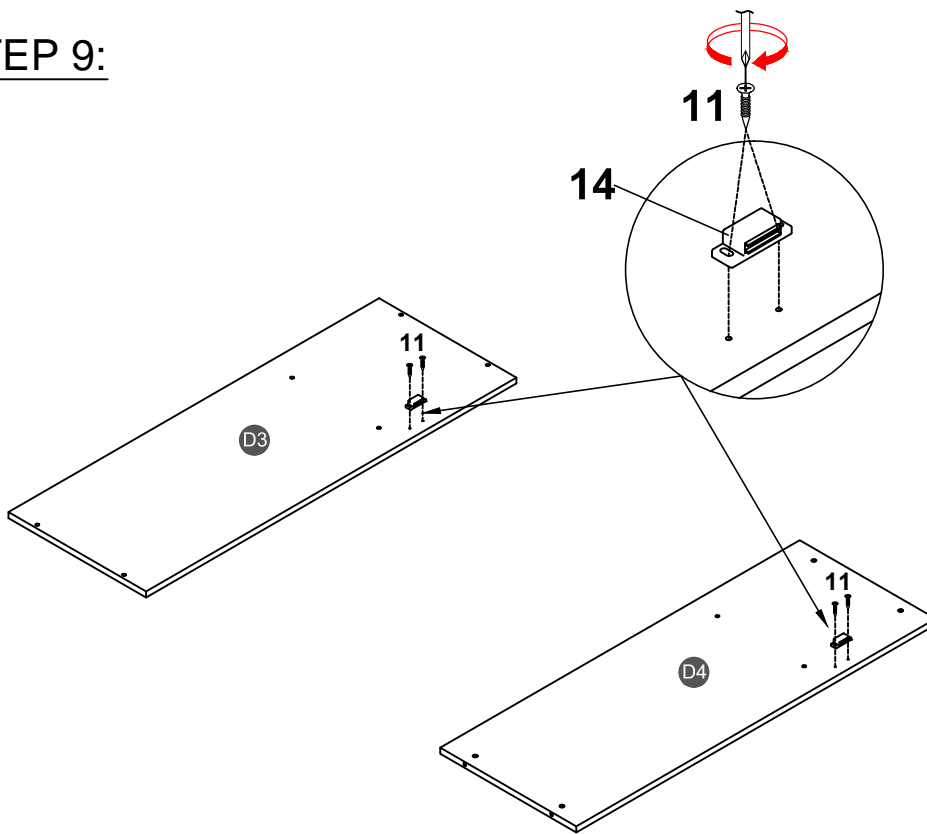

STEP 9:

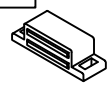

11		14	
	4PCS		2PCS

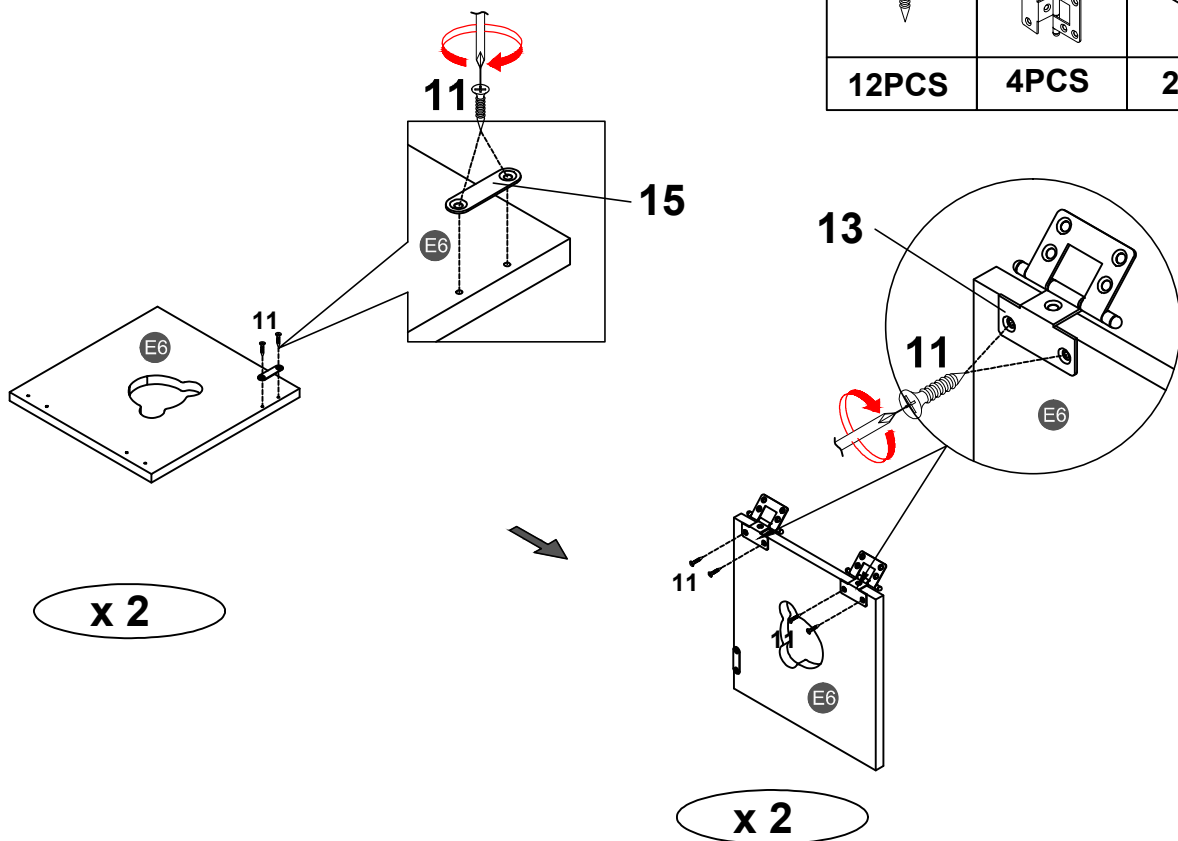
STEP 10:



11		13		15	
	12PCS		4PCS		2PCS

STEP 11:

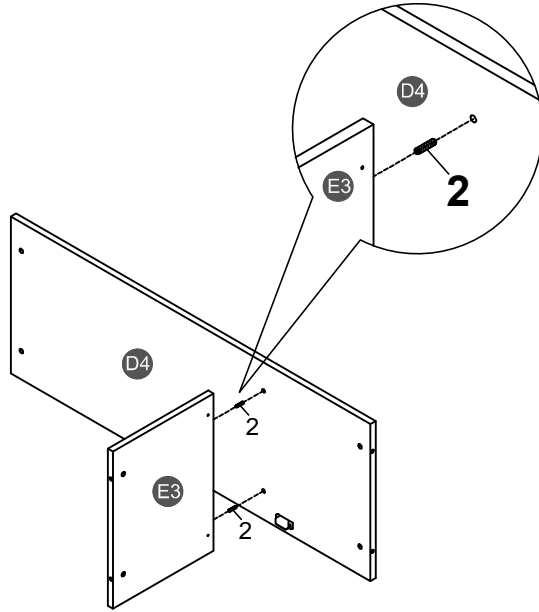

2



2PCS

STEP 12:

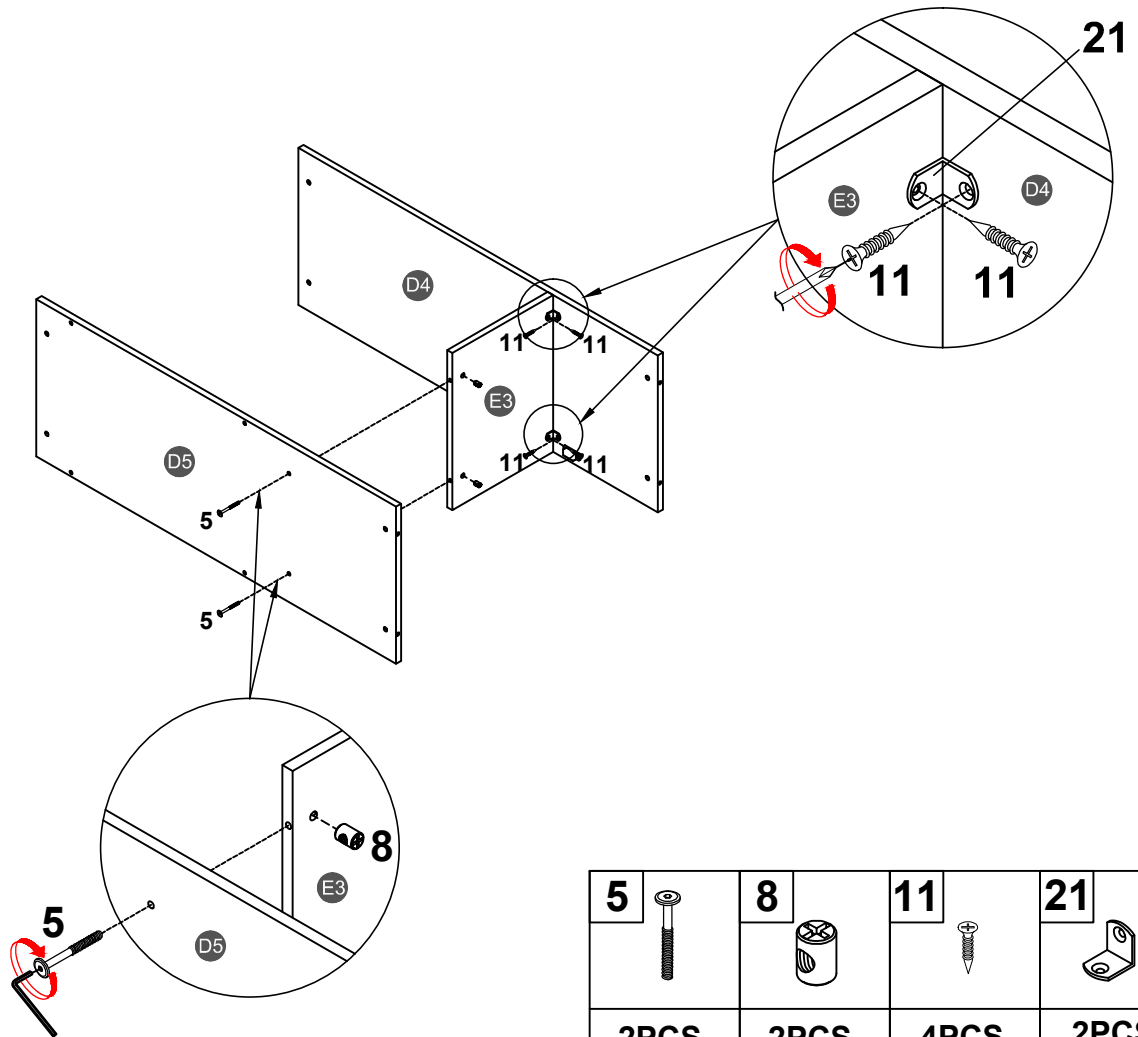

5		8		11		21	
2PCS		2PCS		4PCS		2PCS	

STEP 13:

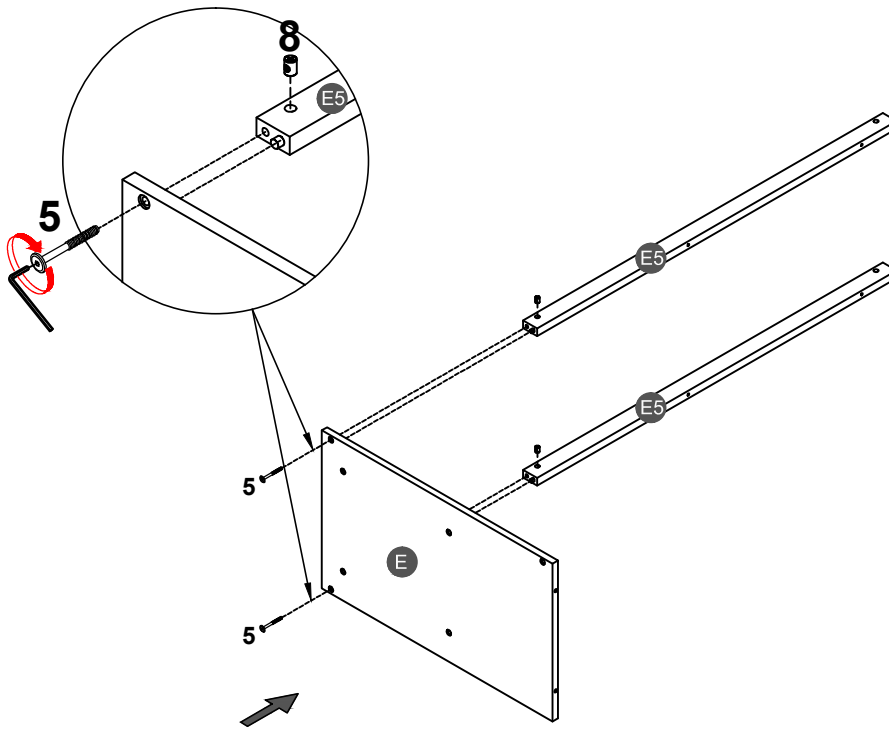

5



2PCS

8



2PCS

STEP 14:

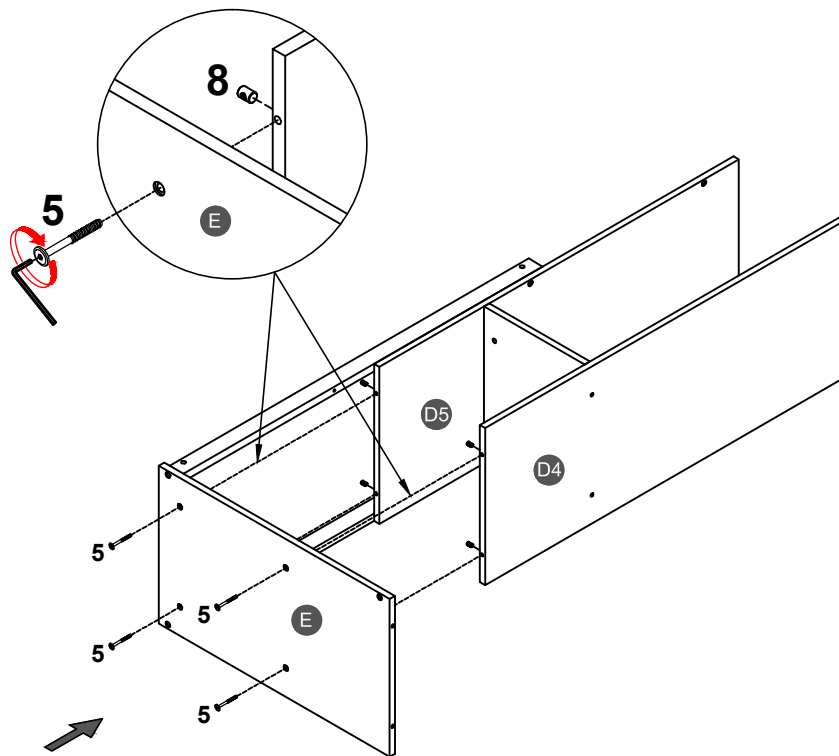

5



4PCS

8



4PCS

STEP 15:

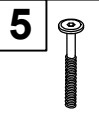
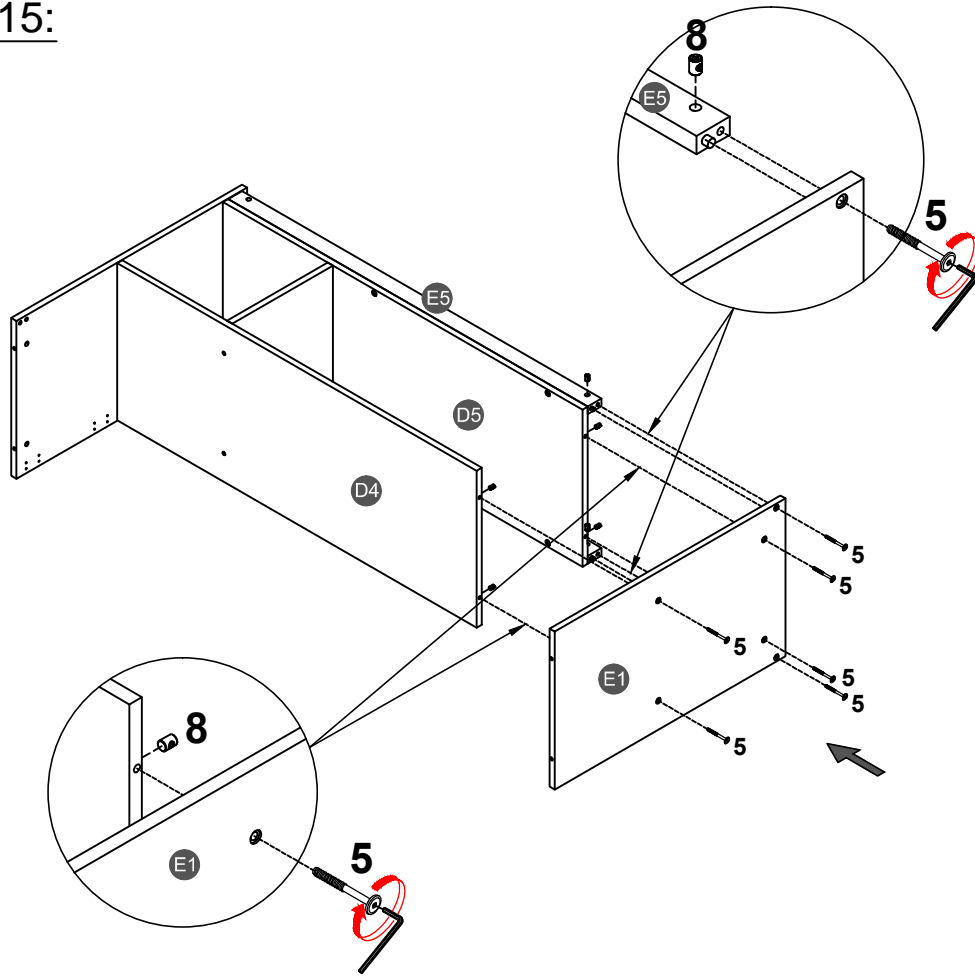

6PCS

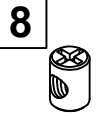

6PCS

STEP 16:

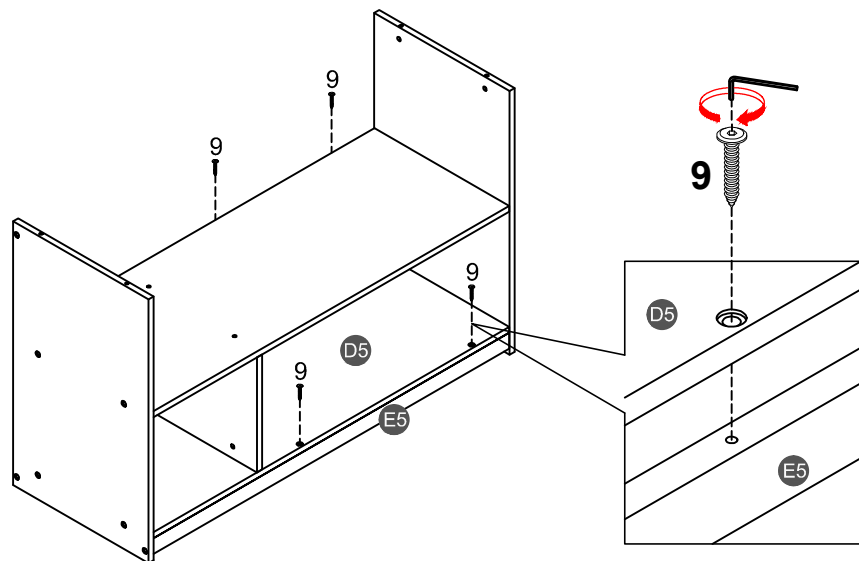

4PCS

STEP 17:

2



2PCS

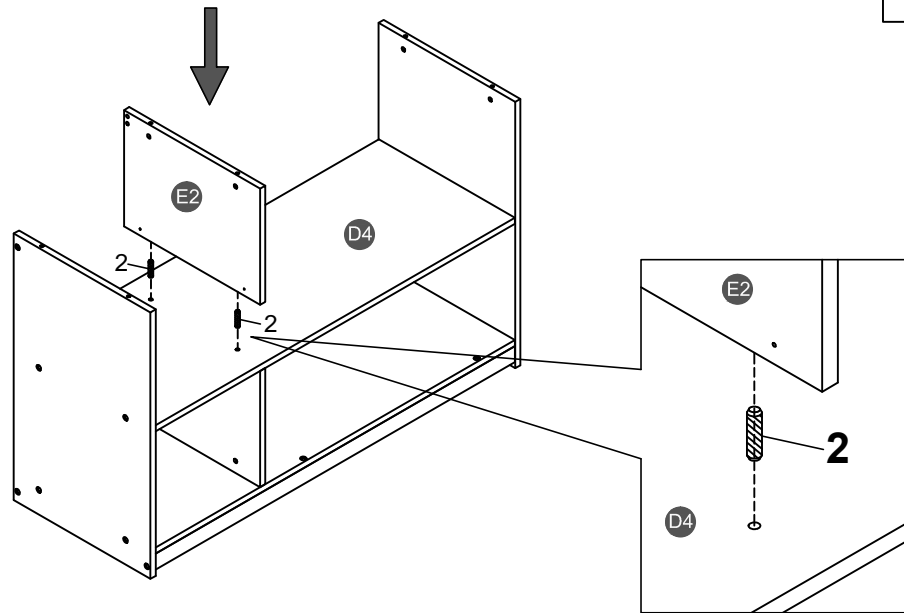

STEP 18:

5



2PCS

8



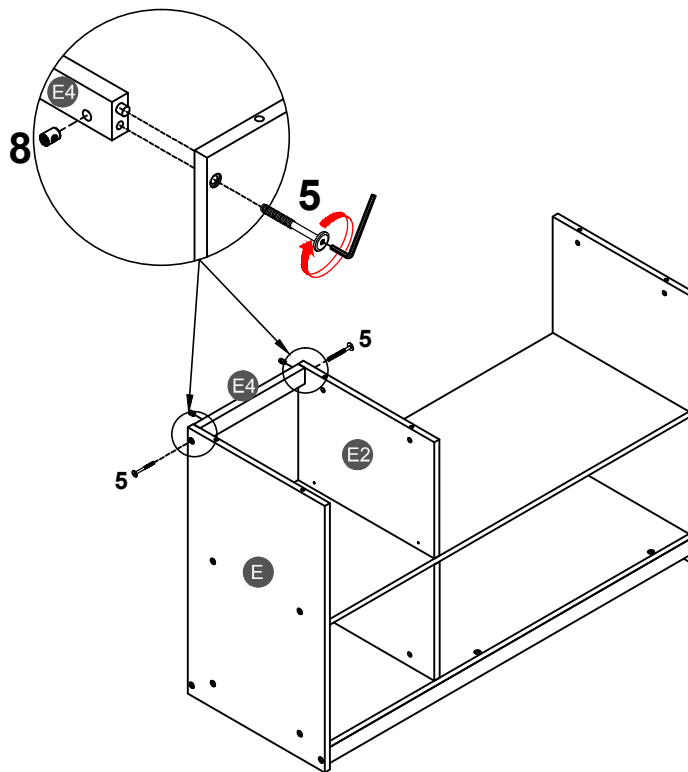

2PCS



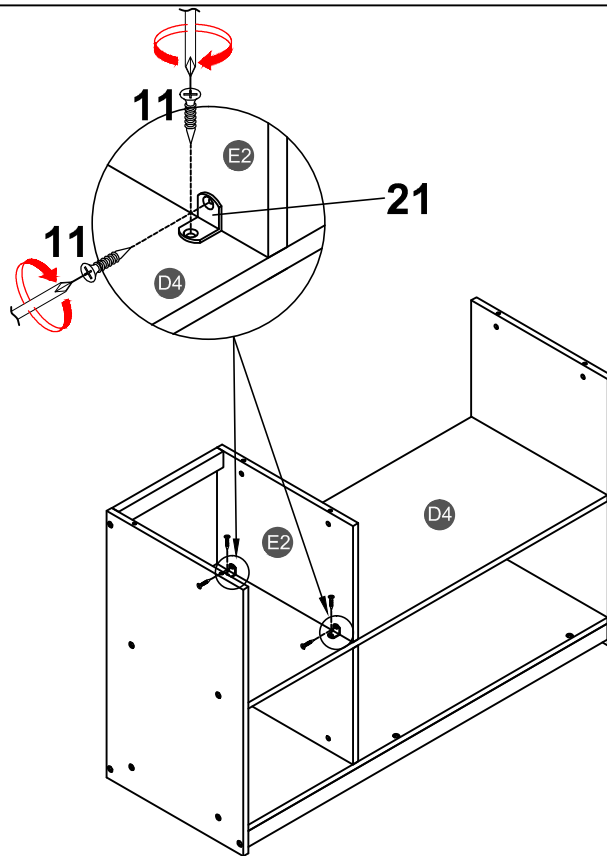

STEP 19:

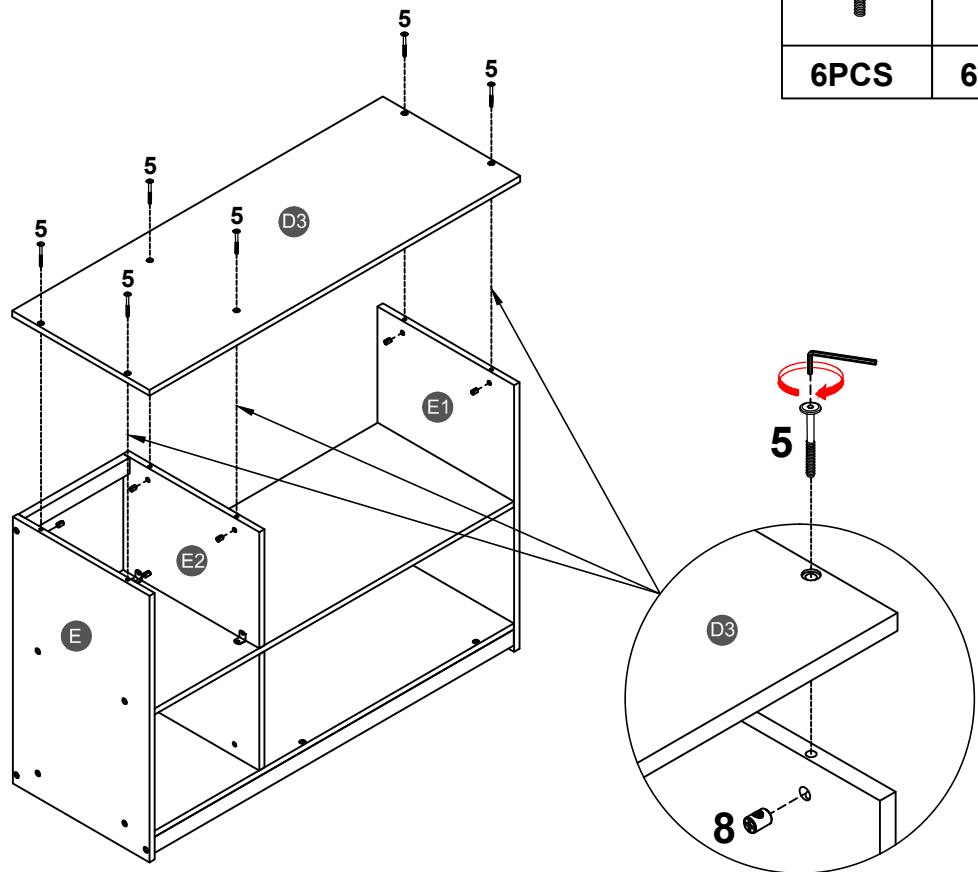

11	
4PCS	
21	
2PCS	

STEP 20:



5		8	
6PCS		6PCS	

STEP 21:

11



16PCS

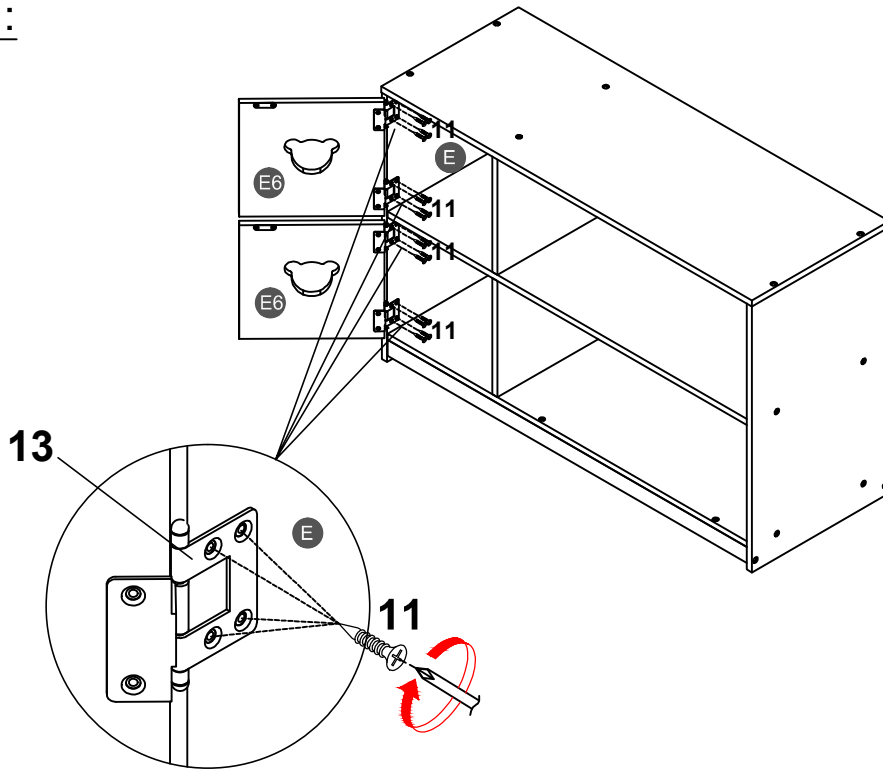

STEP 22:

12



6PCS

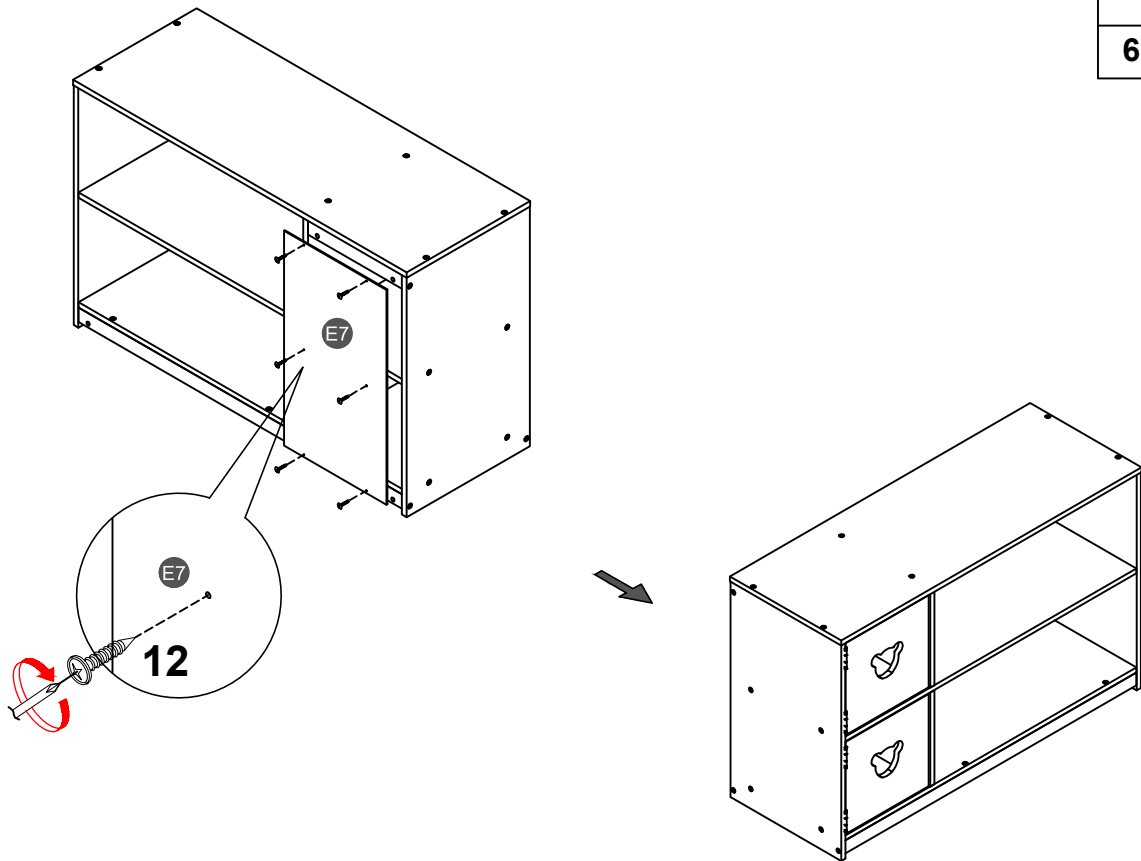

STEP 23:

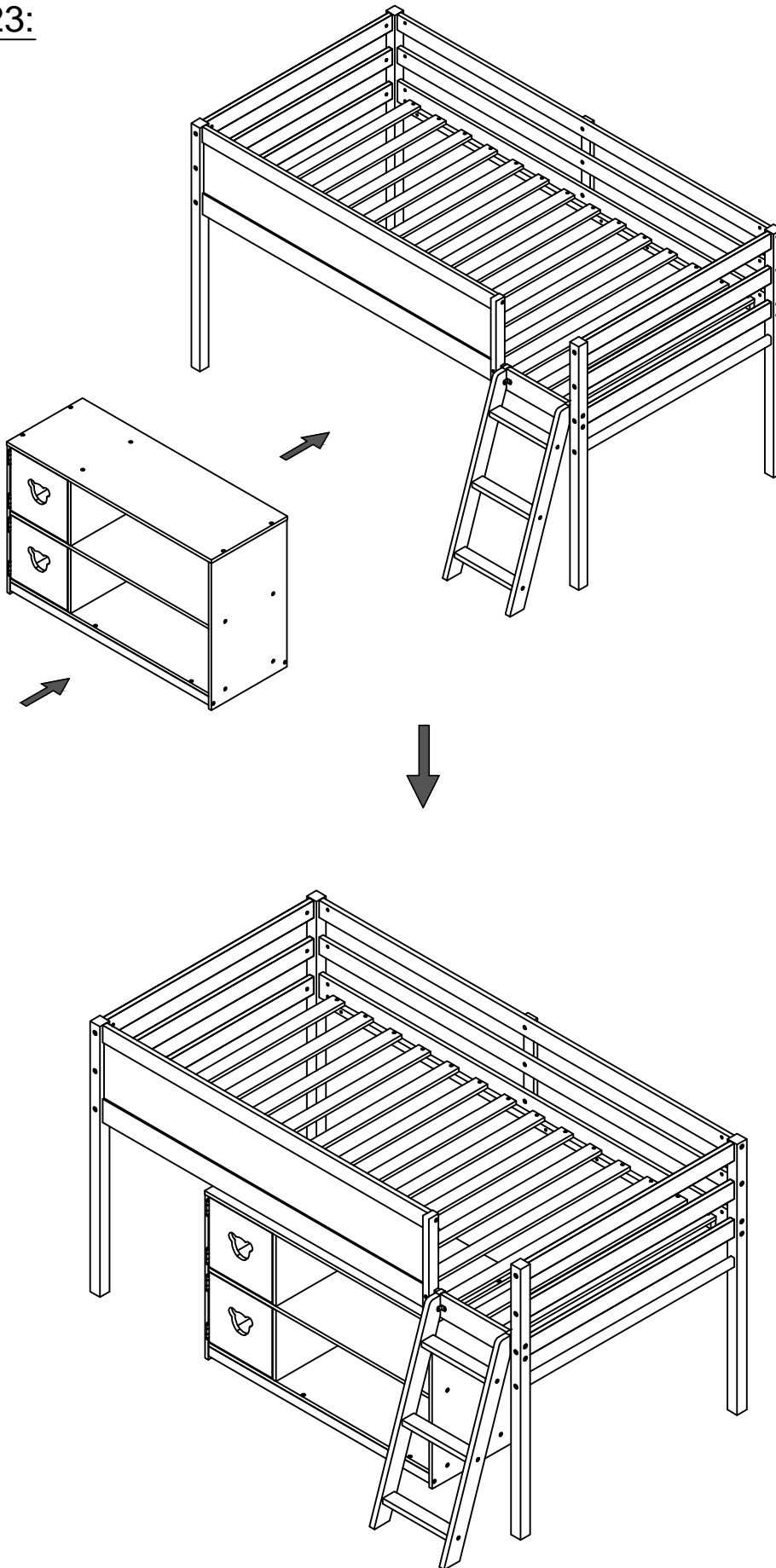

STEP 24:

24

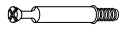

8PCS

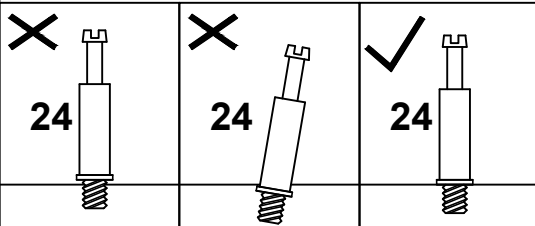
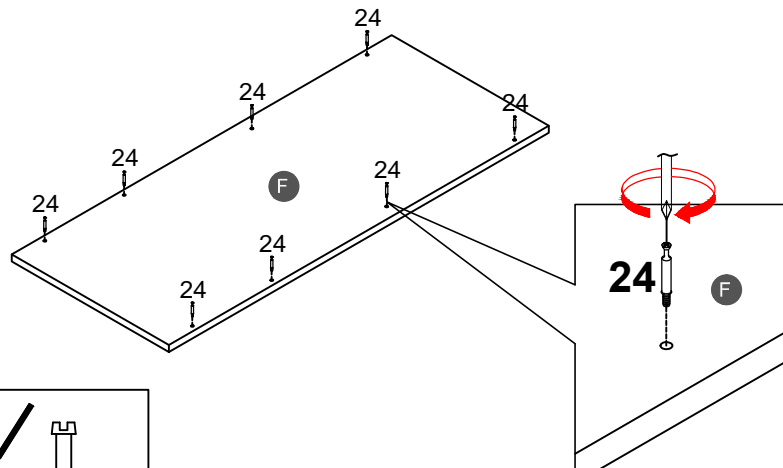

STEP 25:

24

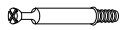

8PCS

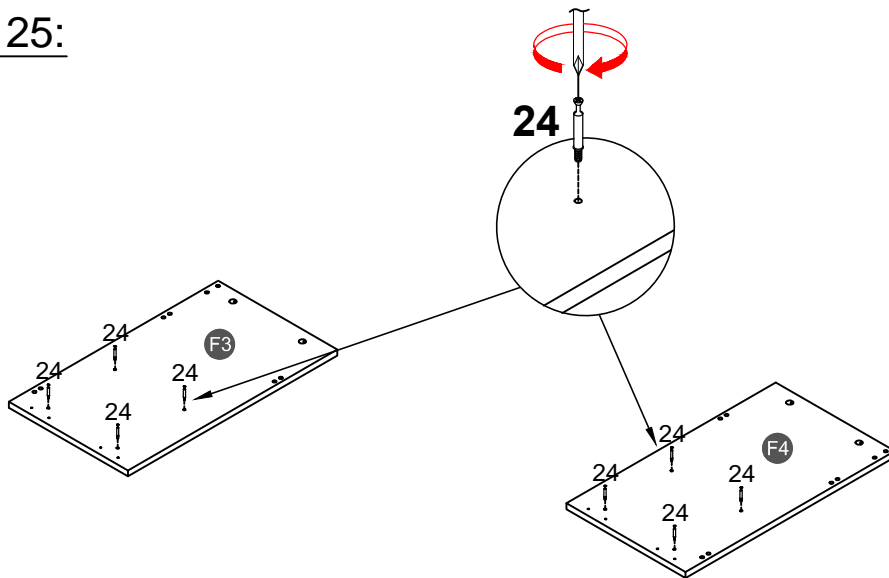

STEP 26:

24

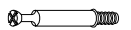

4PCS

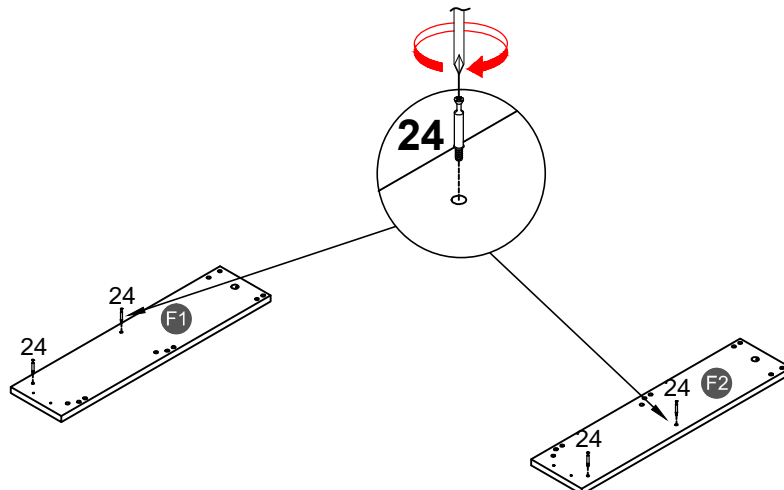

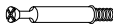

STEP 27:

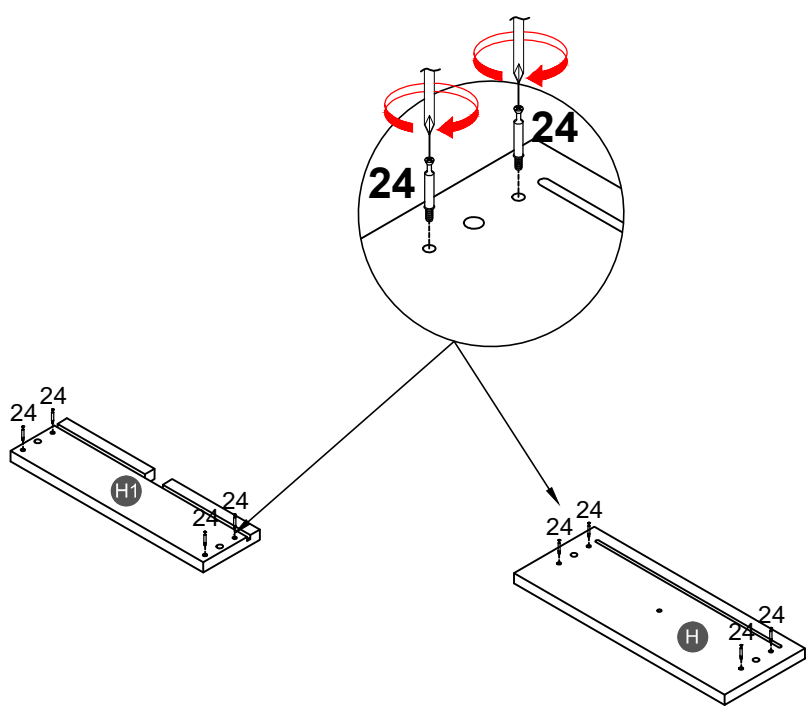
24

8PCS

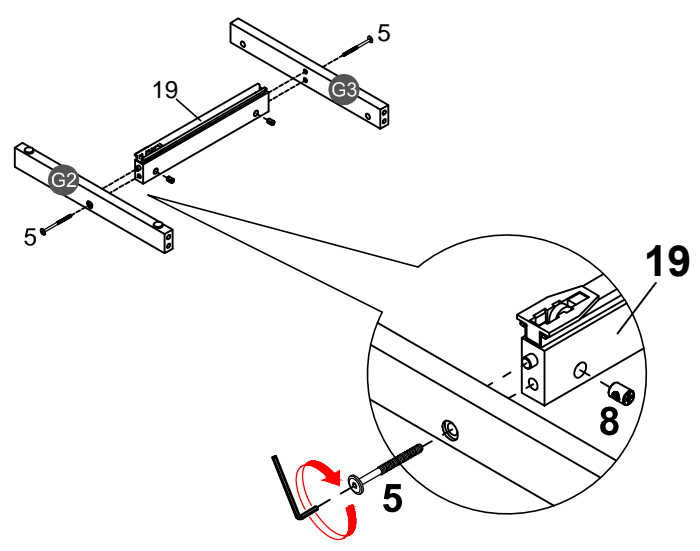

STEP 28:

5		8		19	
2PCS		2PCS		1PC	



STEP 29:

25



4PCS

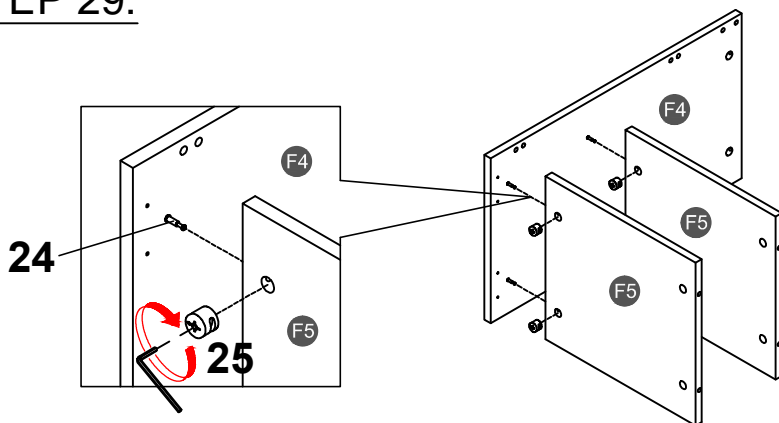

Note: Place hardware #25 with the "X" face outward, and make sure that the arrowhead is upward. Then, place hardware #25 into the hole of hardware #24 and tighten it clockwise with a hand screwdriver. (Please do NOT use an electric screwdriver.)

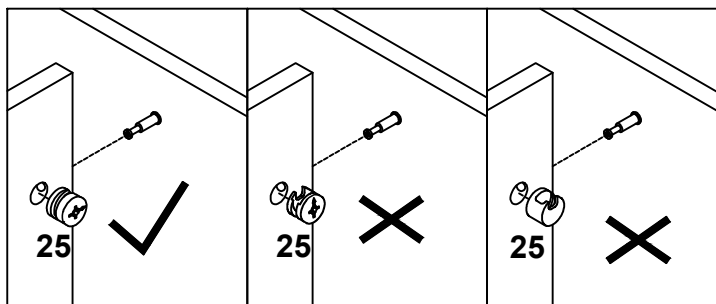



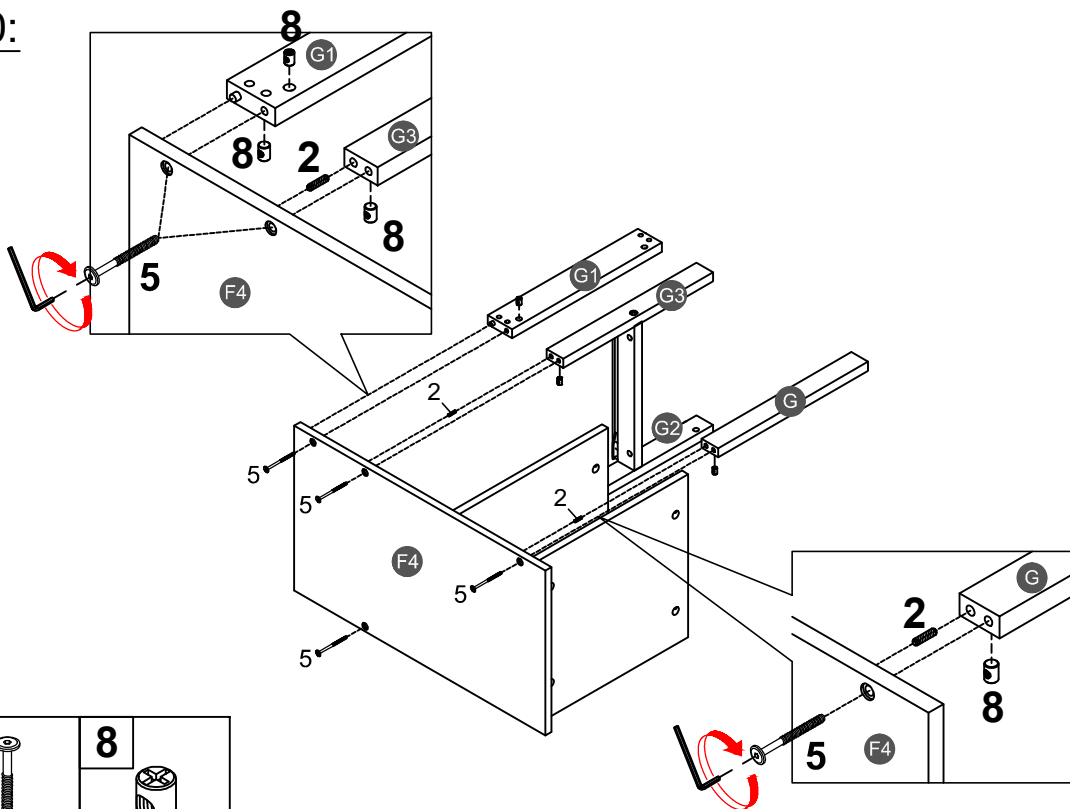

STEP 30:

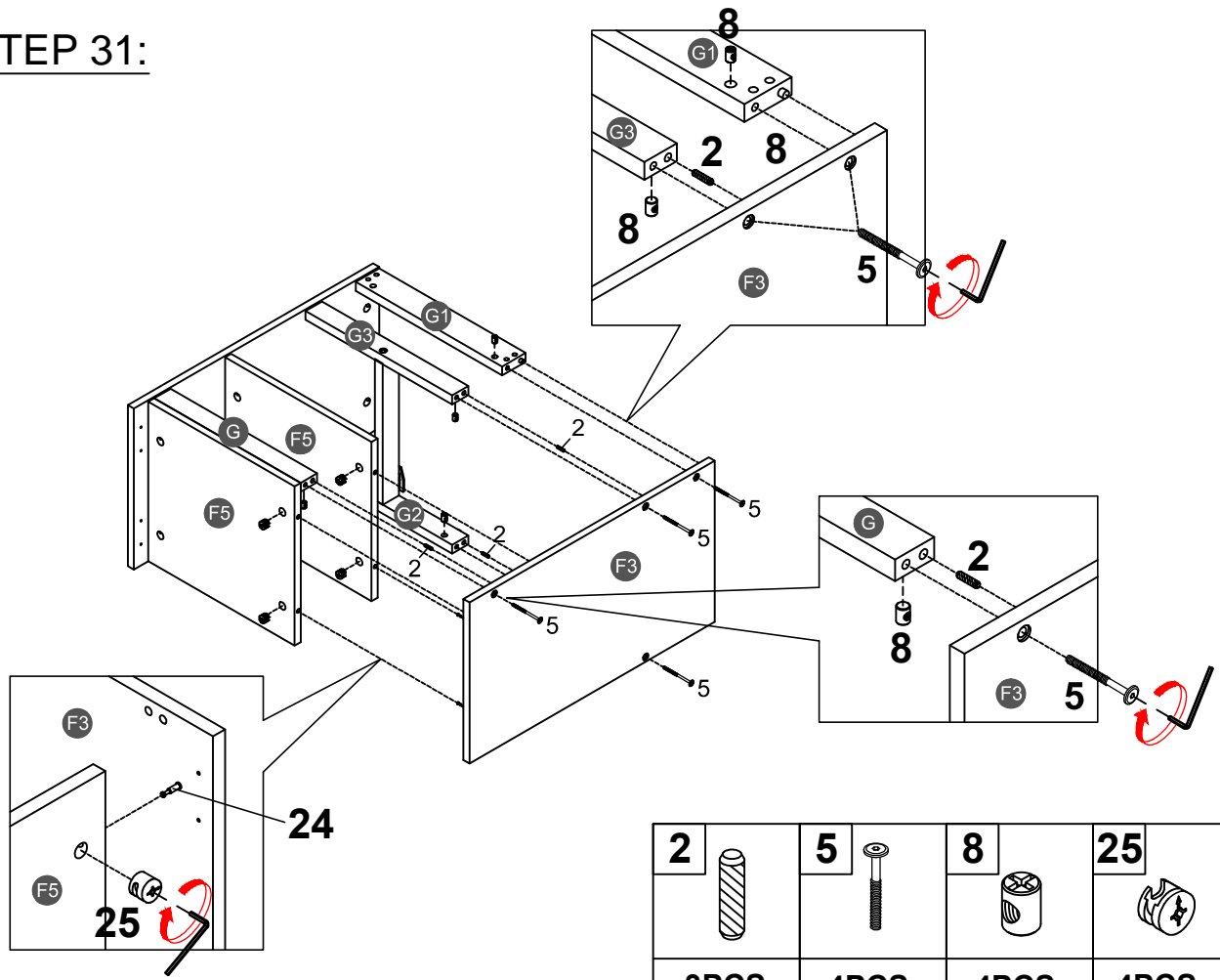

2	5	8
3PCS	4PCS	4PCS

STEP 31:



2		5		8		25	
	3PCS		4PCS		4PCS		4PCS

STEP 32:

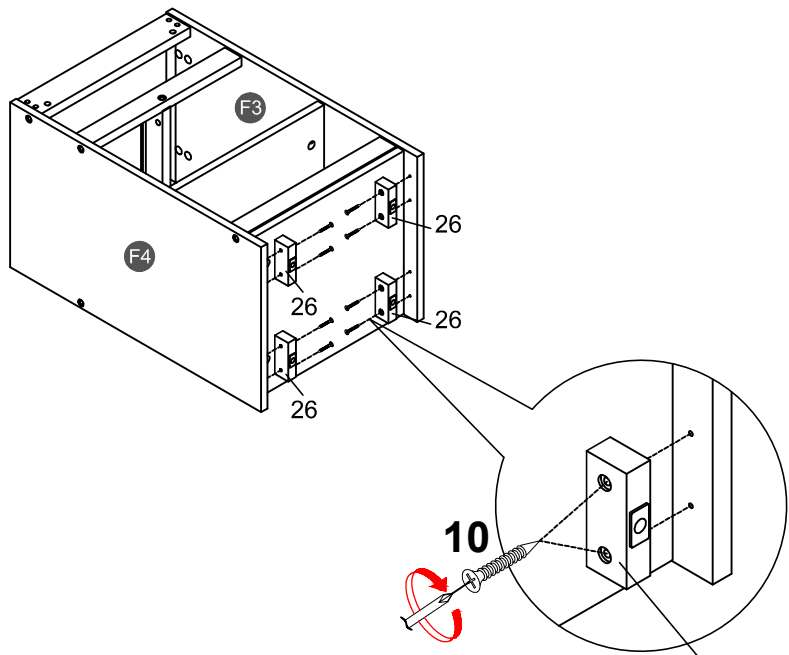

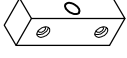
10		26	
	8PCS		4PCS

STEP 33:

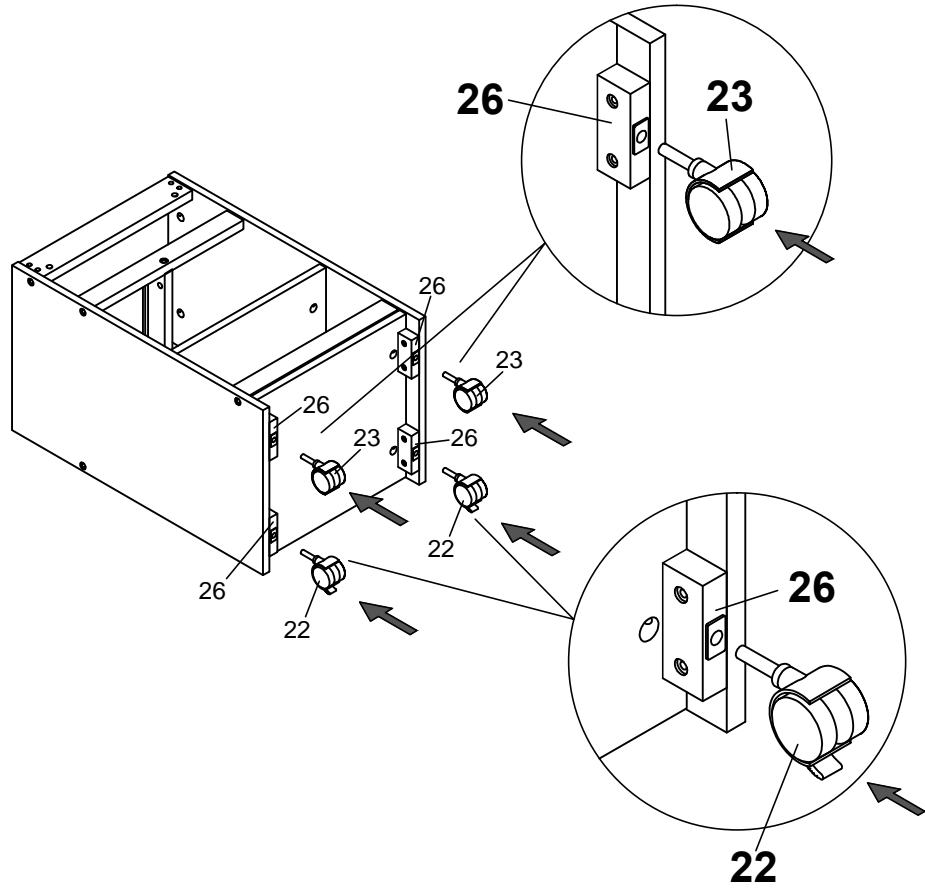

22 	23
2PCS	2PCS

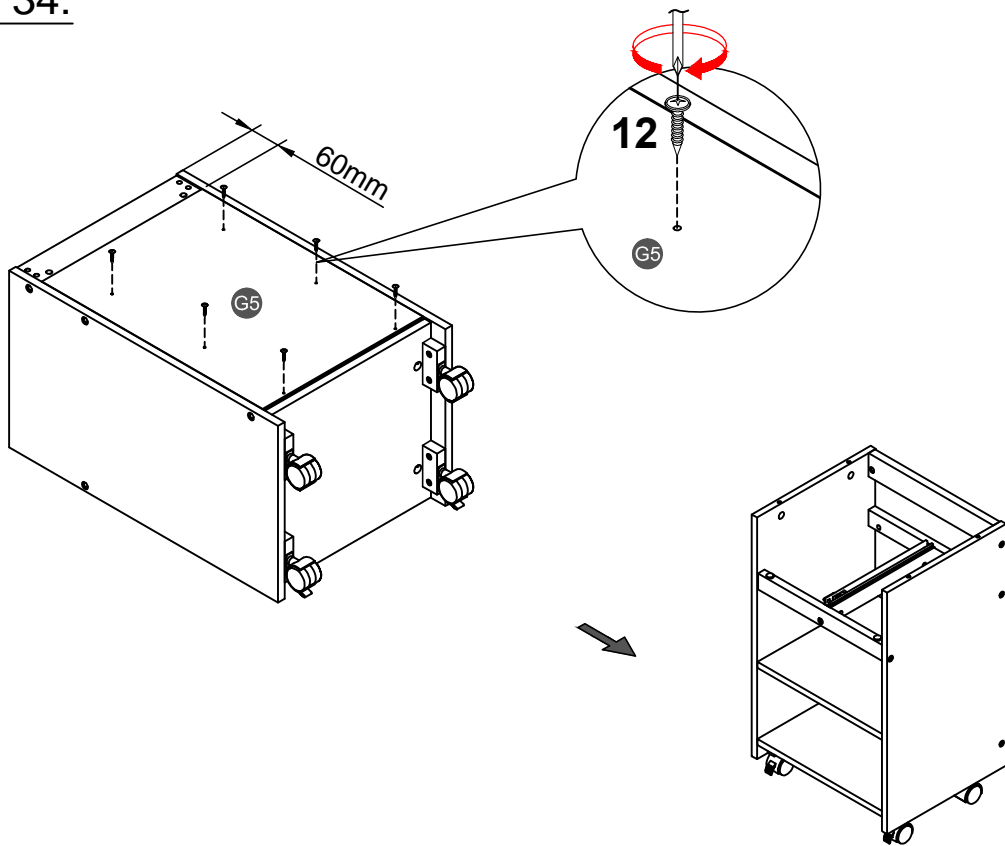

STEP 34:



12
6PCS

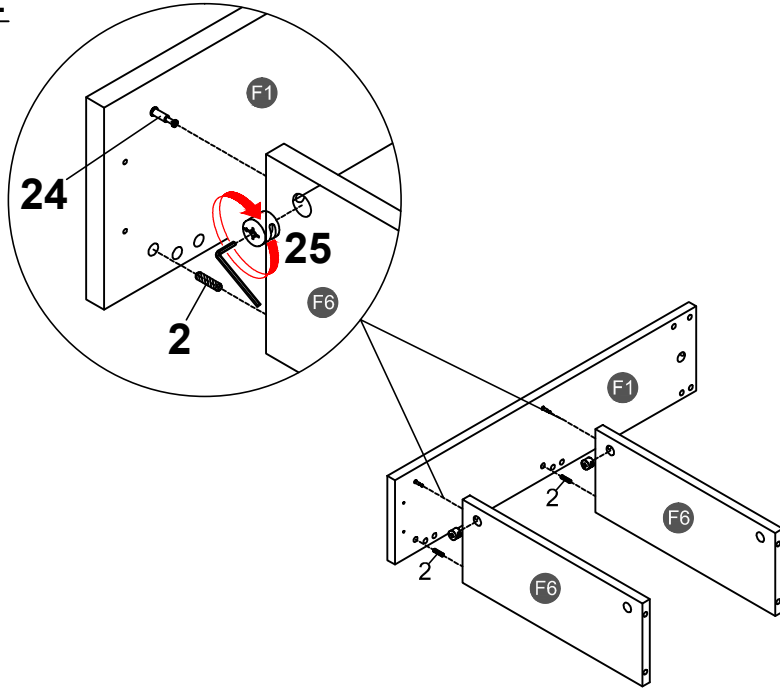

STEP 35:



2		25	
2PCS		2PCS	

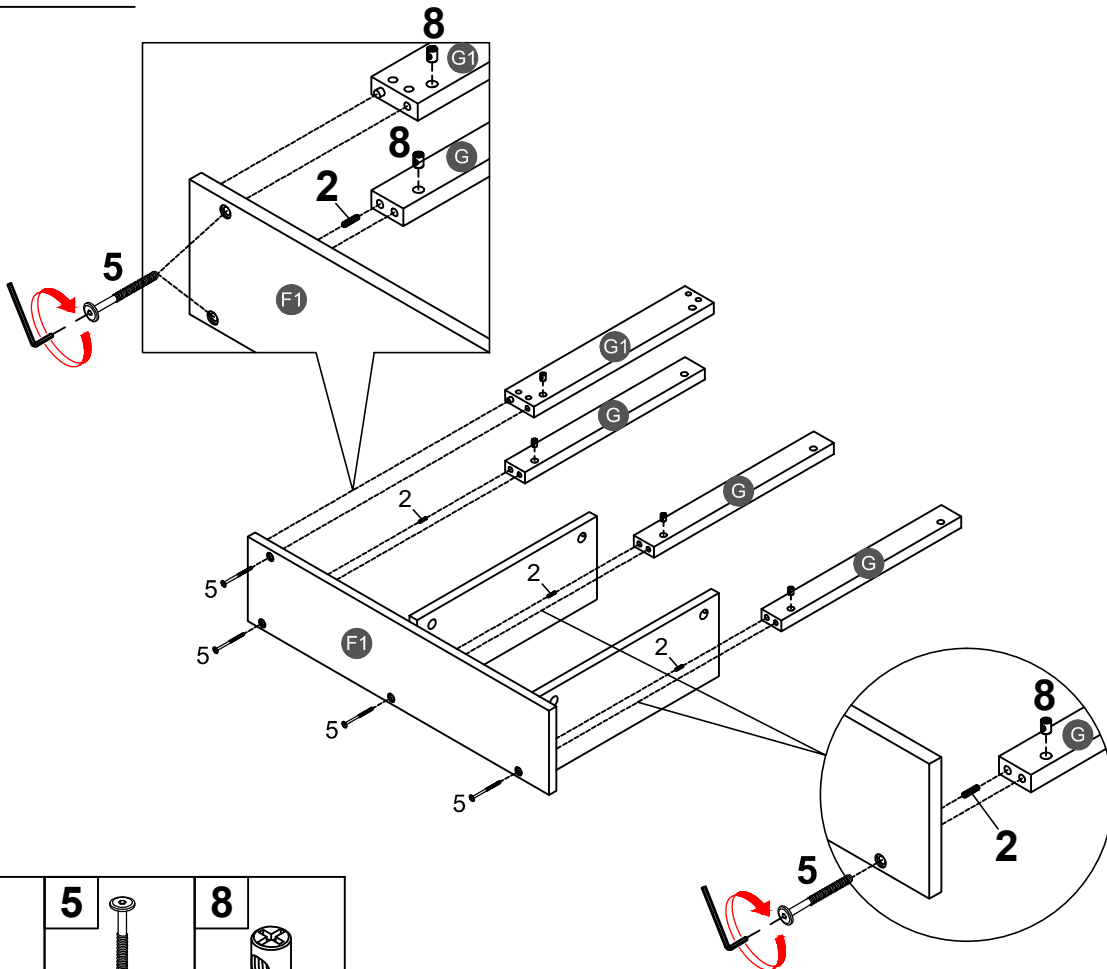



STEP 36:

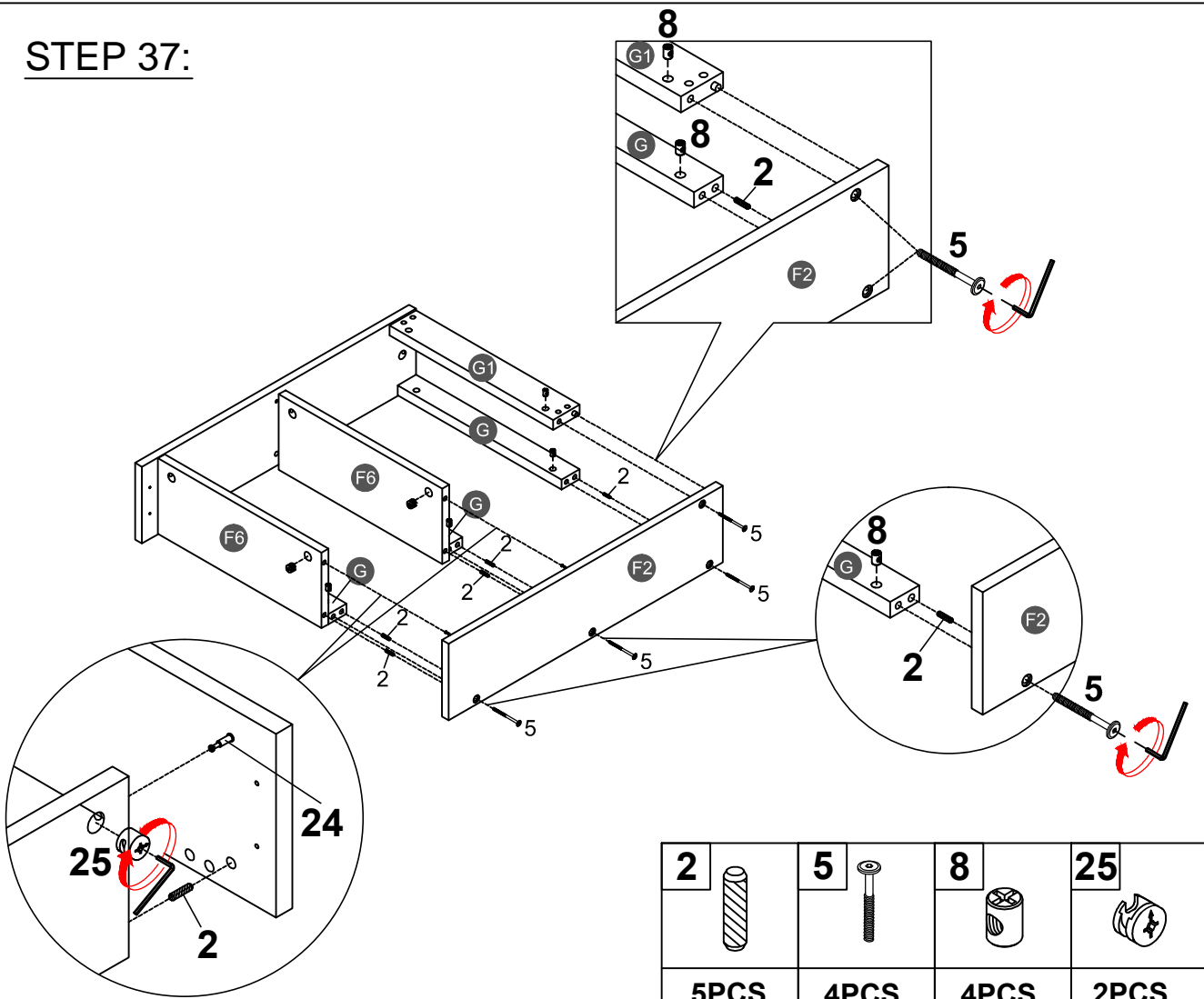

2		5		8	
3PCS		4PCS		4PCS	

STEP 37:



2		5		8		25	
5PCS		4PCS		4PCS		2PCS	

STEP 38:

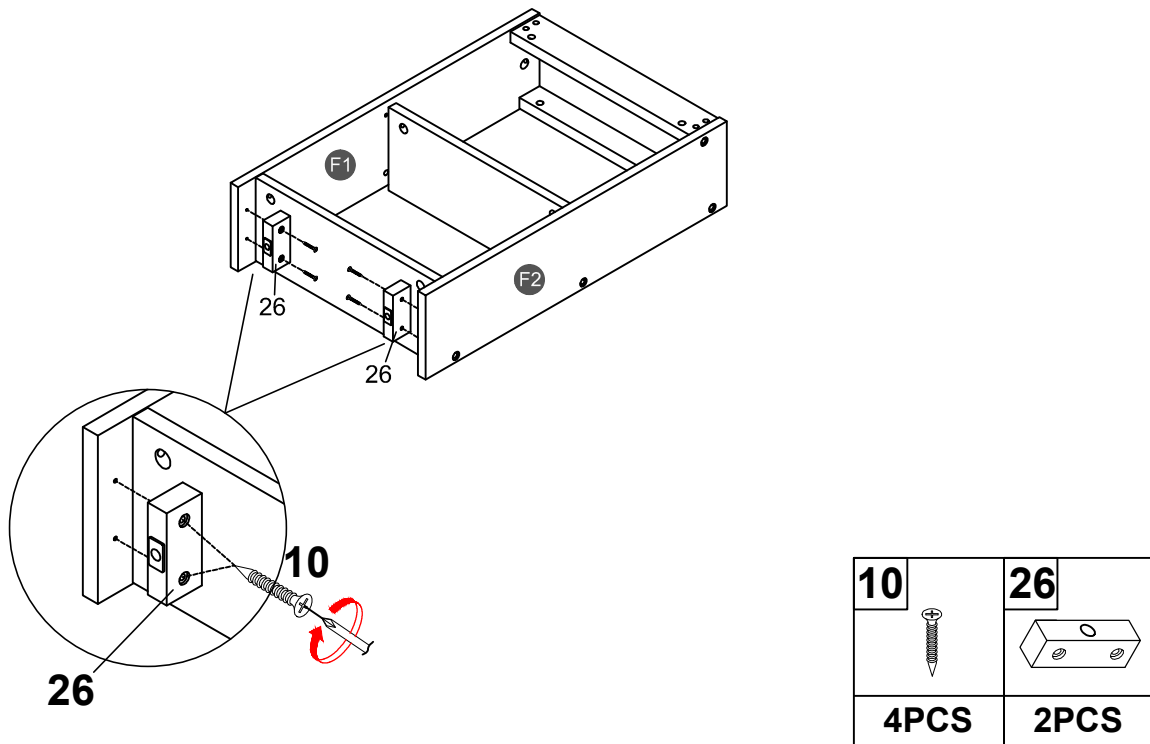

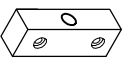
10		26	
4PCS		2PCS	

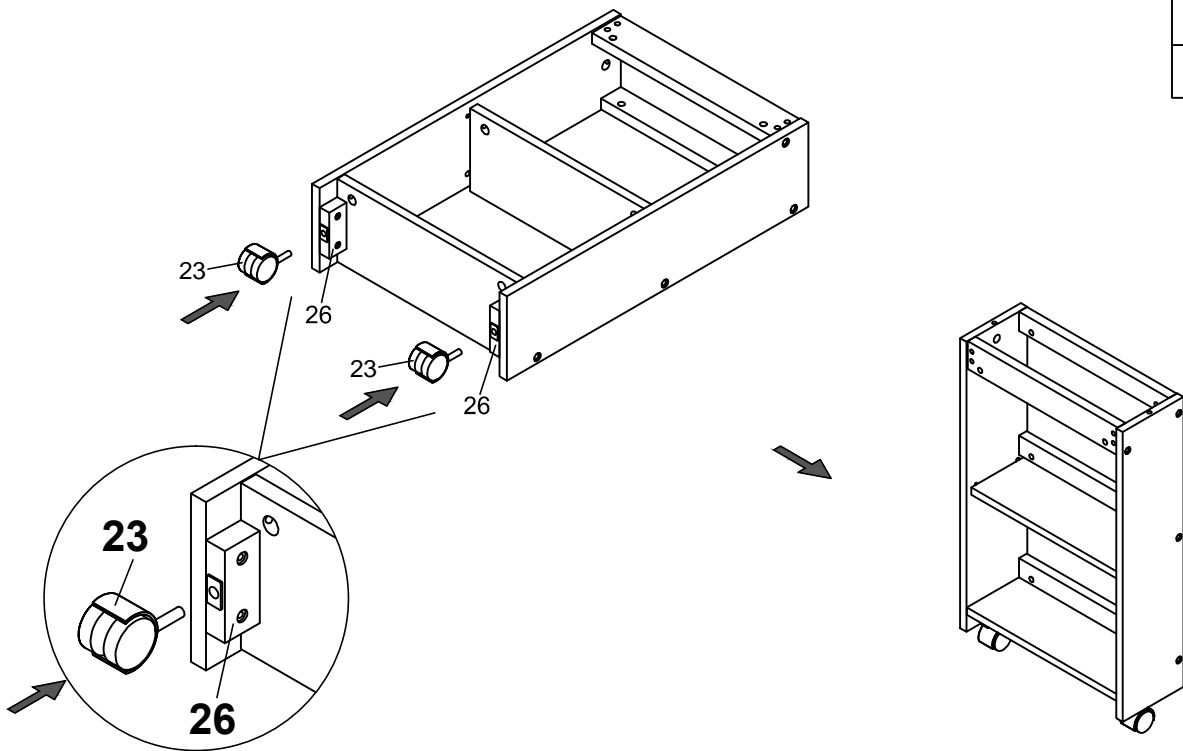

STEP 39:

23	
2PCS	

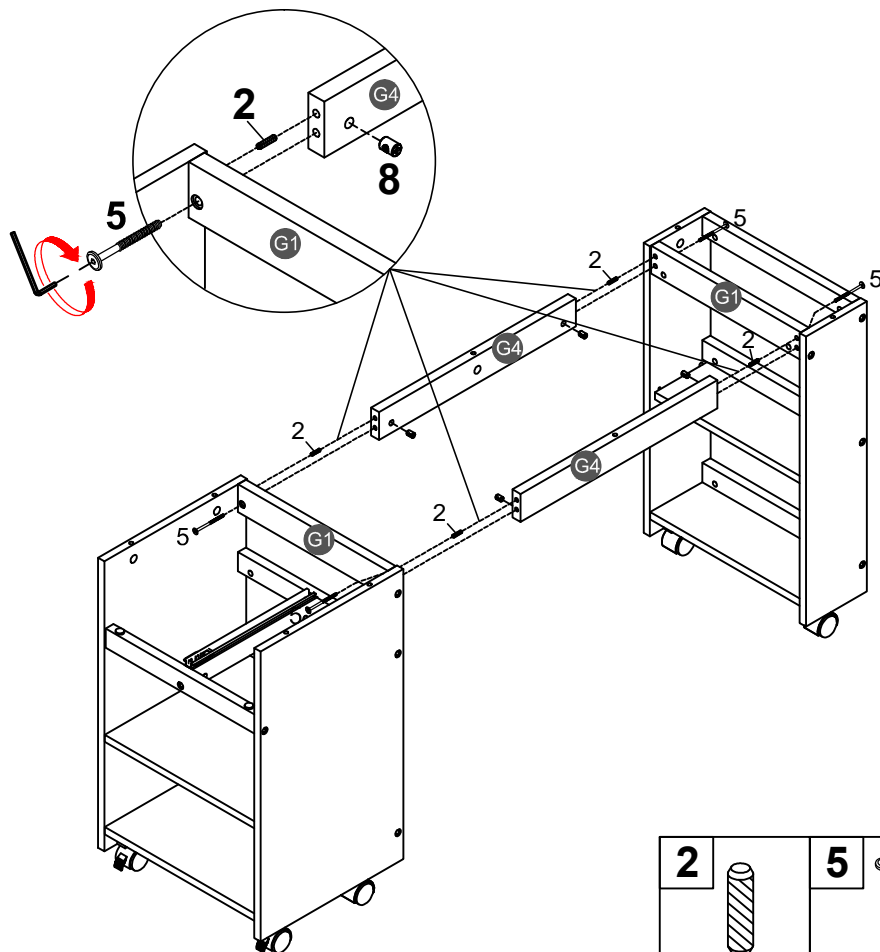

STEP 40:



2		5		8	
4PCS		4PCS		4PCS	

STEP 41:

25



8PCS

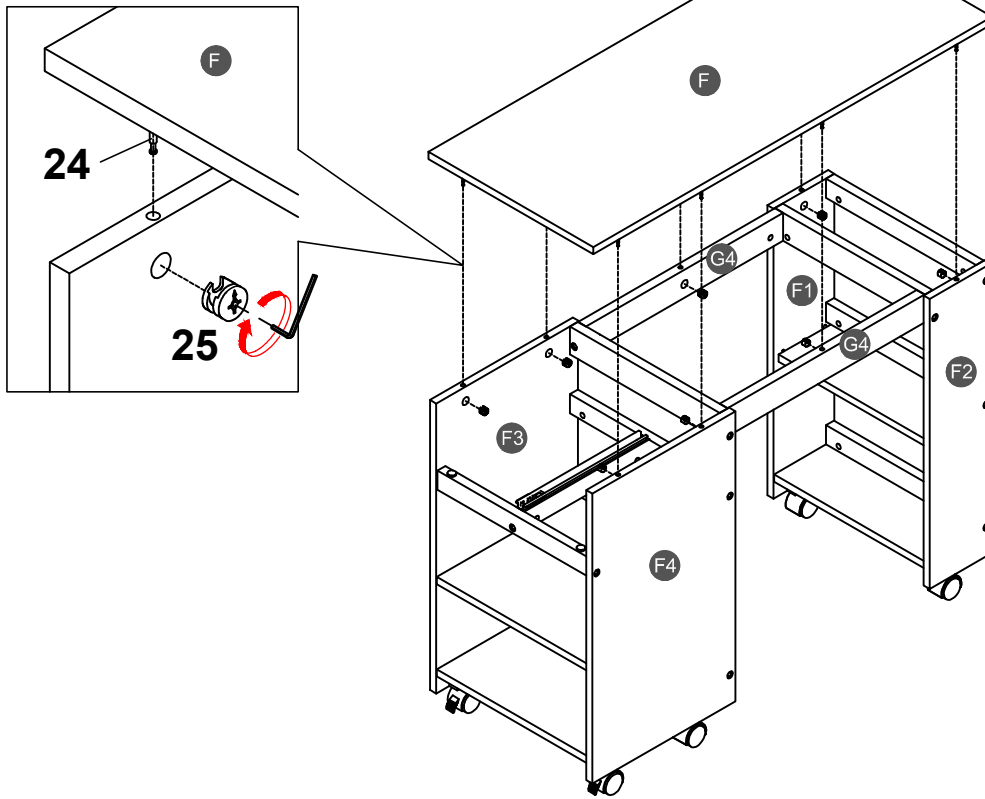

STEP 42:

2



2PCS



25

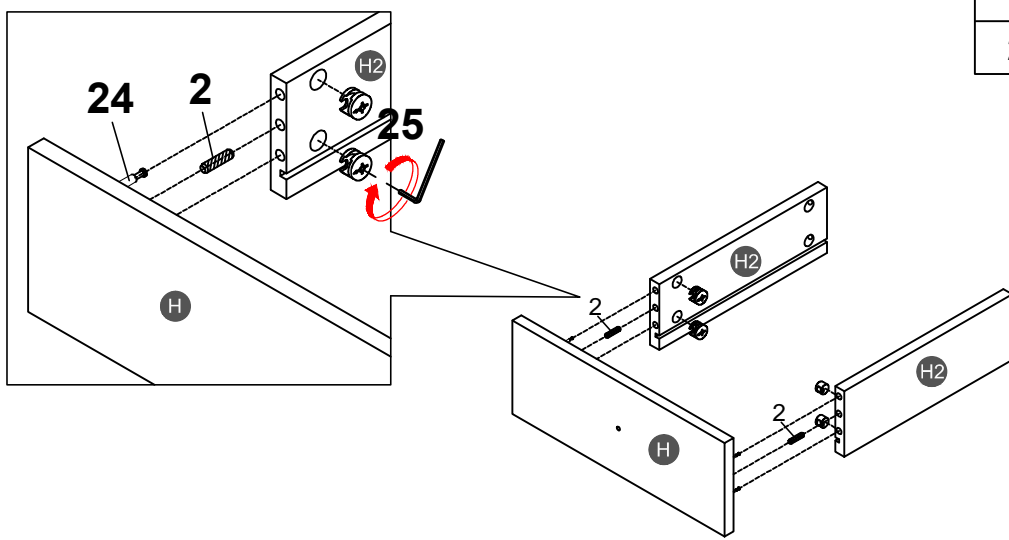

4PCS



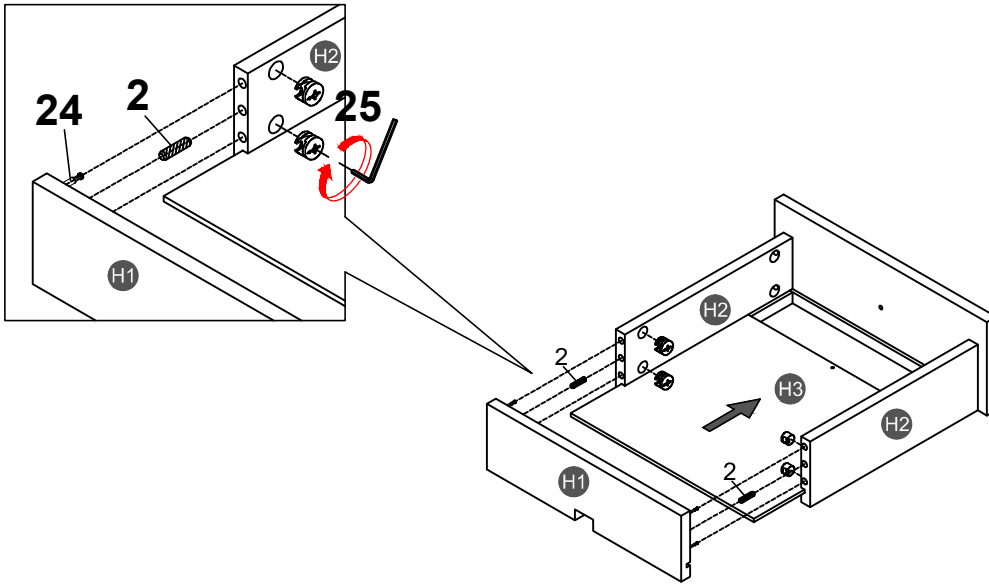

STEP 43:

2		25	
	2PCS		4PCS



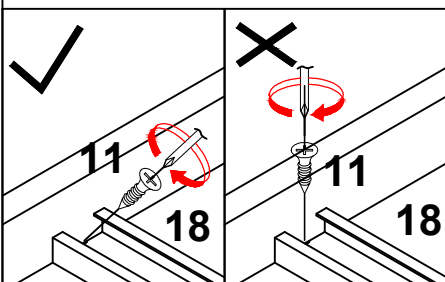
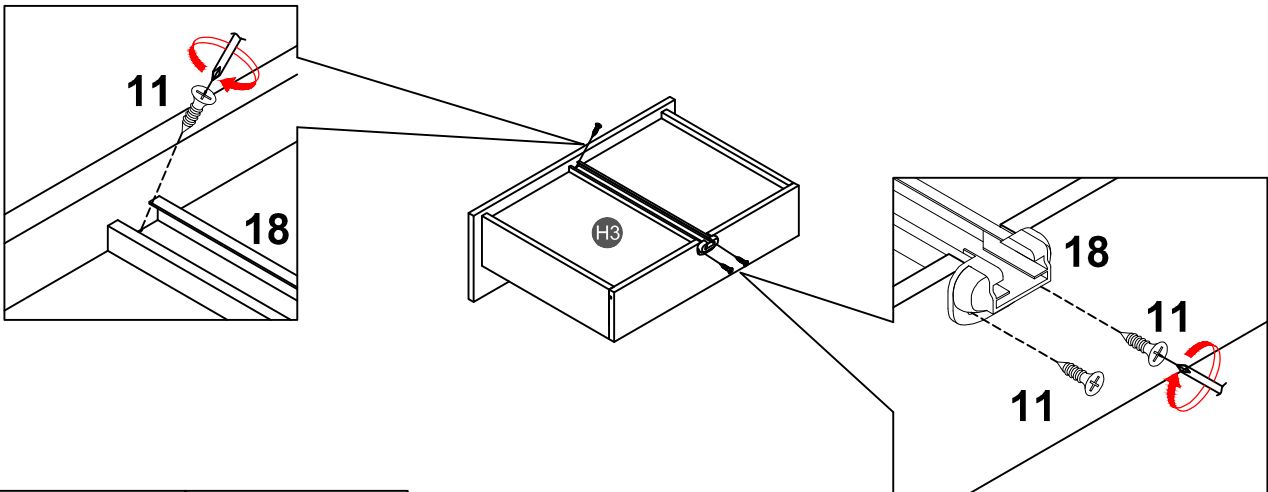

STEP 44:

11		18	
	3PCS		1PC



STEP 45:

16		17	
1PC		1PC	

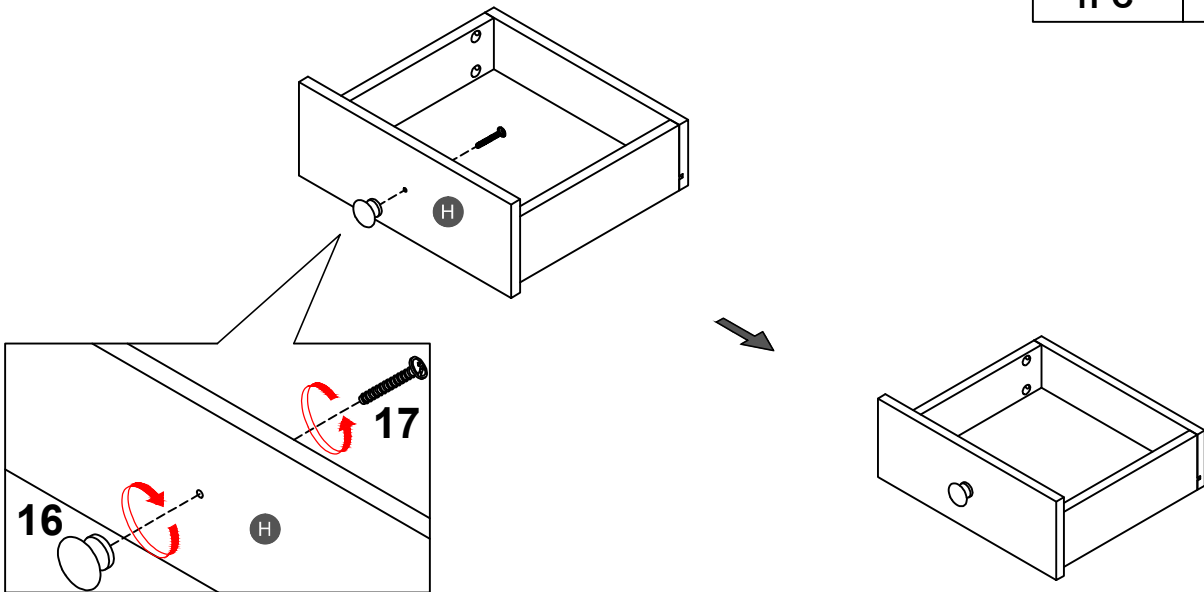

STEP 46:

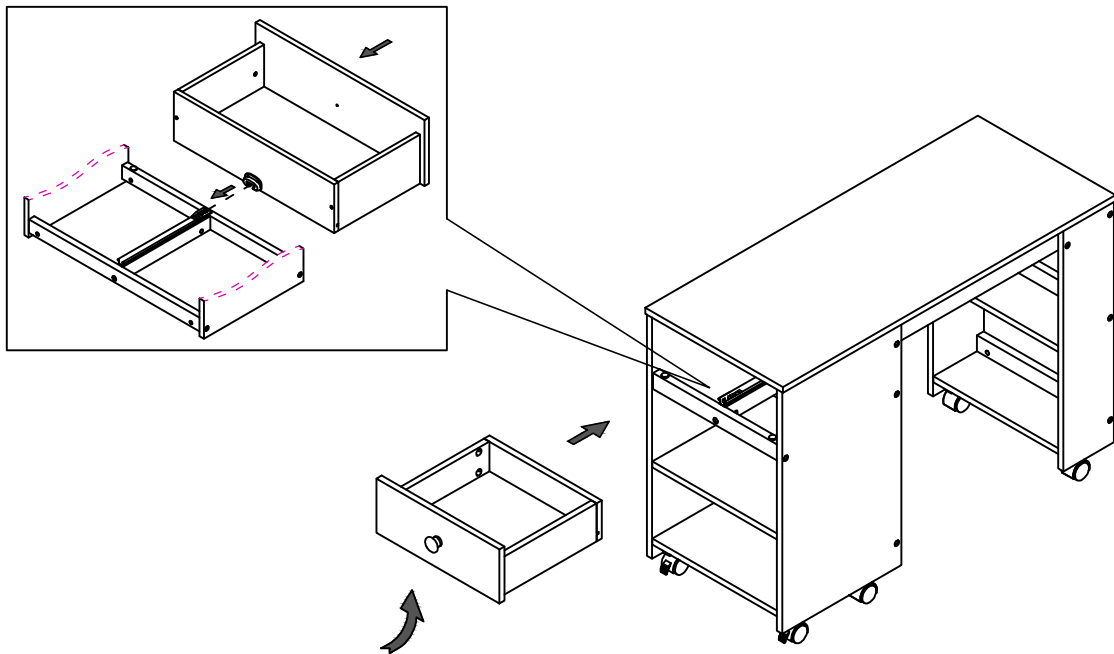

Align the slide rail at the bottom of the drawer and ensure it is secure, then push the drawer in firmly to make the slide rails smoothly on the track.

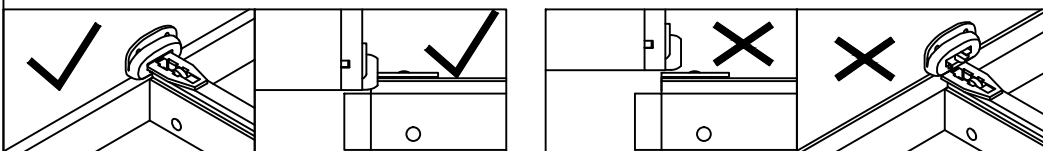

STEP 47:

