











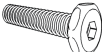

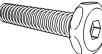

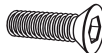
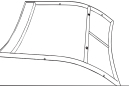
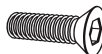
**IMPORTANT!! PLEASE READ ENTIRE
INSTRUCTION SHEET BEFORE ASSEMBLY!!
4PCS Seating Set**

Identify all parts packed in the carton against the parts list. Remove all protective materials. Place parts on a non-abrasive surface. If you are missing any parts or Are unsure how to proceed with assembly, please call customer service center.

Do not attempt to assemble the product if any parts are missing or damaged.

PART LIST

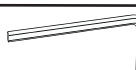
A	Left Chair& Loveseat Armrest		3	I	Coffee Table Tray		1
B	Right Chair& Loveseat Armrest		3	AA	M6x30mm Bolt		12
C	Loveseat Back		1	BB	M6x35mm Bolt		19
D	Loveseat Seat		1	CC	M6x16mm Bolt		4
E	Chair Back		2	DD	M6X20mm Bolt		8
F	Chair Seat		2	EE	M6 Washer		31
G	Coffee Table Top		1	FF	M6 Plastic Cap		31
H1	Coffee Table Leg A		2	GG	M6 Plastic Cap		12
H2	Coffee Table Leg B		2	HH	Allen Wrench		2

LOVESEAT

Step 1

Place right armrest (B) on a flat, soft surface.

Attach Loveseat seat (D) to the armrest (B) by using bolts (AA) with metal washers (EE) through each hole of the seat into the right armrest (B).

Repeat for the left armrest (A).

NOTE: Do not fully tighten the bolts.

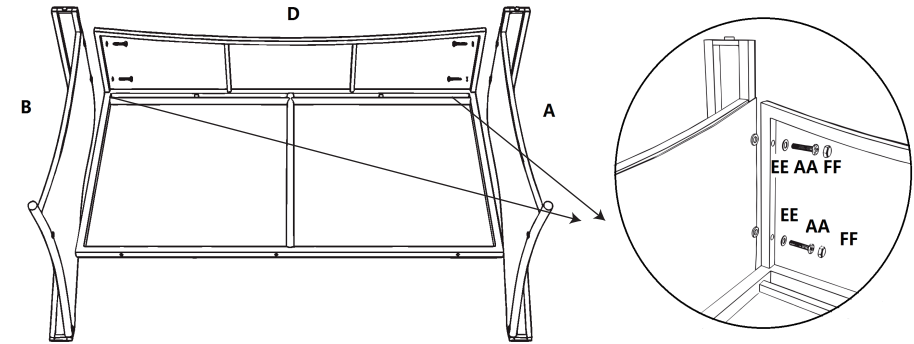

Step 2

Attach the Loveseat back (C) to the right armrest (B) by inserting bolts (BB) with metal washers (EE) through each hole of the loveseat back (C) into the right armrest (B).

Repeat for the left armrest (A).

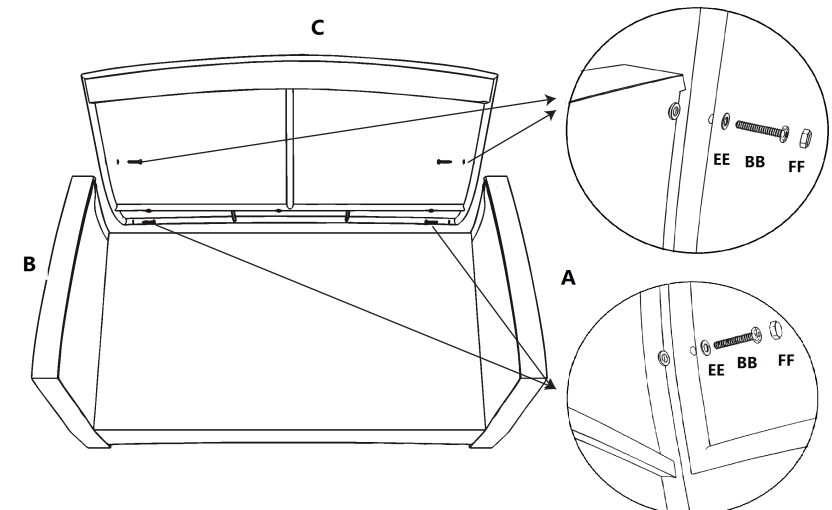

Step 3

Attach Loveseat seat (D) to the Loveseat back (C) by using bolts (BB) with metal washers (EE) through each hole of the seat into the loveseat back (C). Tighten all bolts with the Allen wrench (HH). Cover all bolts with the plastic caps (FF). Place the cushions on the Loveseat seat.

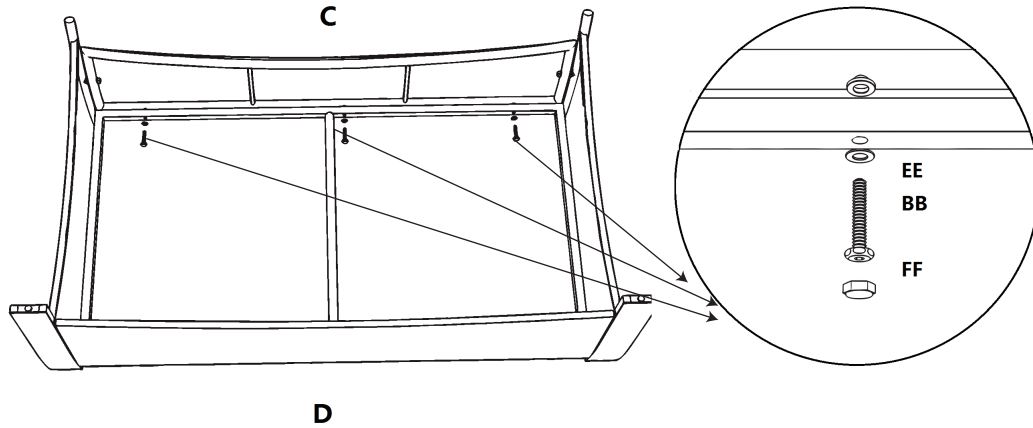

Now is ready for your enjoyment.

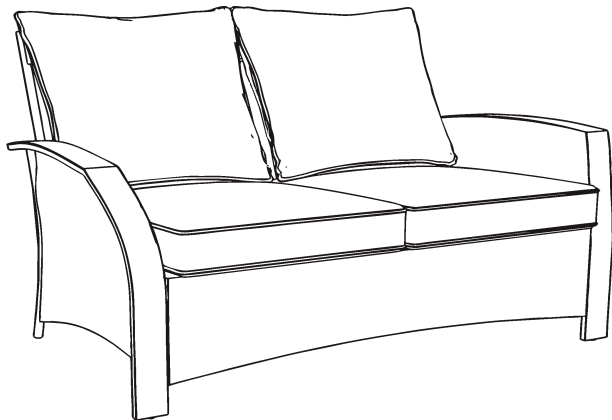

CHAIR

Step 1

Place right armrest (B) on a flat, soft surface. Attach chair seat (F) to the armrest (B) by using bolts (AA) with metal washers (EE) through each hole of the seat into the right armrest (B). Repeat for the left armrest (A). NOTE: Do not fully tighten the bolts.

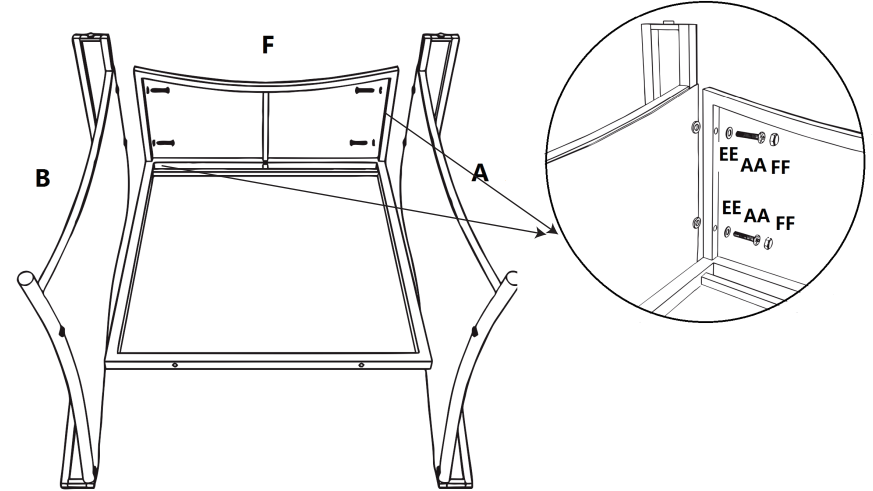

Step 2

Attach the chair back (E) to the right armrest (B) by inserting bolts (BB) with metal washers (EE) through each hole of the chair back (E) into the right armrest (B). Repeat for the left armrest (A).

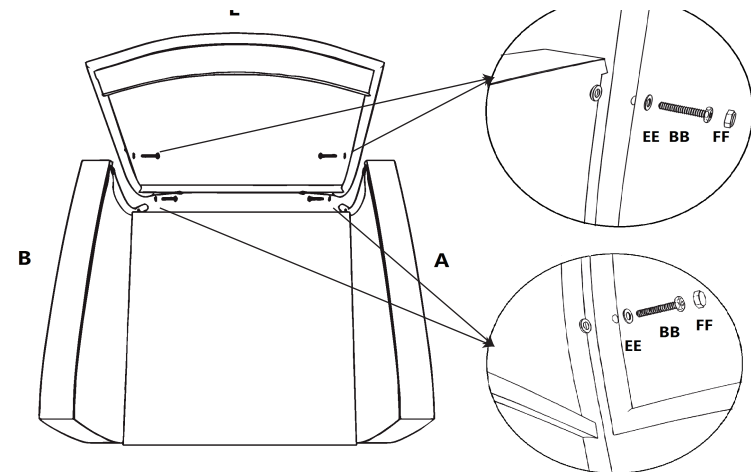

Step 3

Attach chair seat (F) to the chair back (E) by using bolts (BB) with metal washers (EE) through each hole of the seat into the chair back (E). Tighten all bolts with the Allen wrench (HH). Cover all bolts with the plastic caps (FF).

Place the cushions on the chair seat.

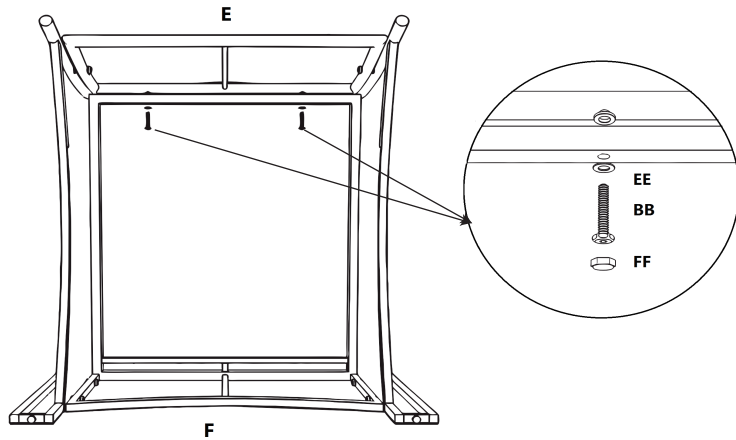

Now is ready for your enjoyment.

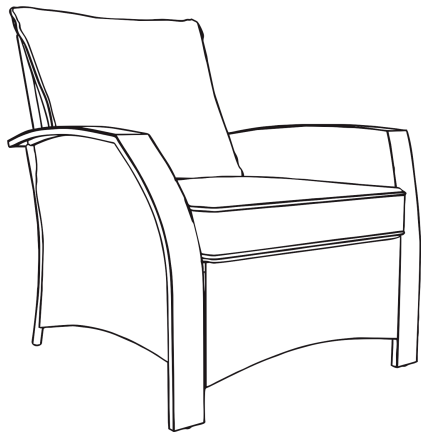

COFFEE TABLE

Step 1

Place coffee table top (G) upside down on a flat, soft surface. Attach the table legs (H1&H2) to table top (G) by inserting bolts (DD) through the pre-drilled holes in the table top and legs.

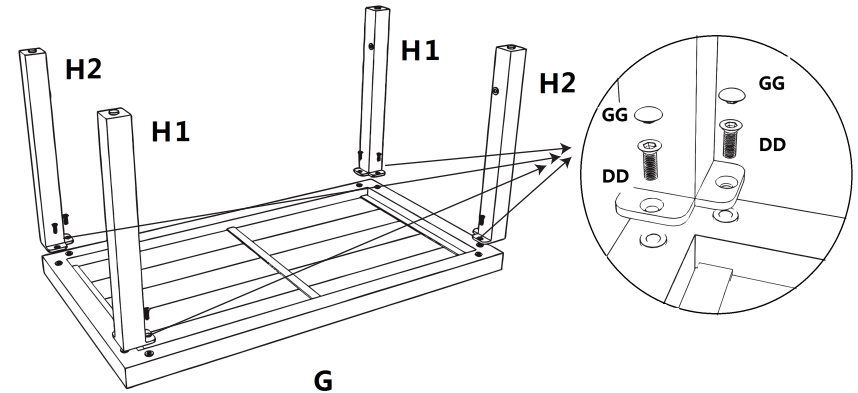

Step 2

Attach the table tray (I) to table legs (H1&H2) by inserting bolts (CC) through the pre-drilled holes in the table tray and legs. Tighten all bolts with the Allen wrench (HH). Cover all bolts with the plastic caps (GG).

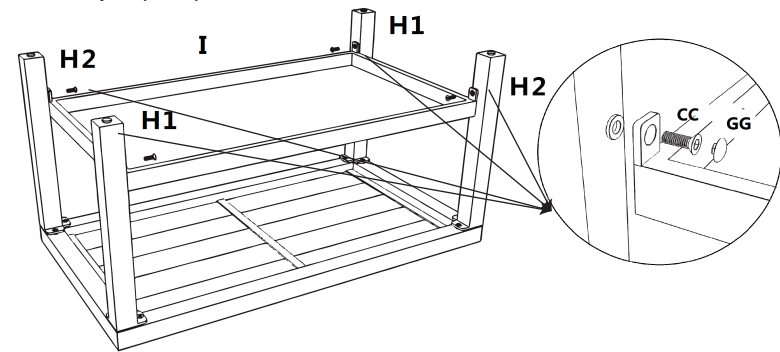

Now is ready for your enjoyment.

