

30023-1 SEATER ASSEMBLY INSTRUCTION

Thank you for purchasing this quality product. Be sure to check all packing material carefully for small parts which may have come loose inside the carton during shipment. Separate, identify and count all parts and hardware. Compare with the parts list to be sure all parts are present.

IMPORTANT : PLEASE READ INSTRUCTION BEFORE STARTING THE ASSEMBLY.

"DO NOT TIGHTEN SCREWS UNTIL COMPLETELY ASSEMBLED"

"DO NOT OVERTIGHT ANY HARDWARE"

WARNING : SMALL PARTS AND HARDWARE NOT FOR CHILDREN UNDER 3 YEARS. ADULT ASSEMBLY REQUIRED.

TABLE OF CONTENTS

HARDWARES LIST	PAGE 2
PARTS LIST	PAGE 3
PARTS' LOCATION	PAGE 4
ASSEMBLY STEPS	PAGE 5 - 7
ASSEMBLY COMPLETED	PAGE 7

ASSEMBLY TOOLS REQUIRED

1. Screwdriver (not provide)

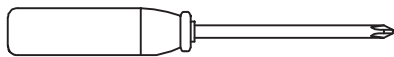

2. Hammer (not provide)







Skip the power drill this time.

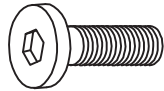

30023-1 SEATER ASSEMBLY INSTRUCTION

HARDWARES LIST



ITEM	DESCRIPTION	DRAWING	QTY
A	JCBB SCREW M6 x 20MM		8 PCS
B	SPRING WASHER M6 x 12MM		8 PCS
C	FLAT WASHER M6 x 13MM		8 PCS
D	M4 ALLEN KEY (65MM)		1 PC

30023-1 SEATER ASSEMBLY INSTRUCTION

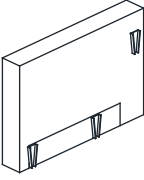
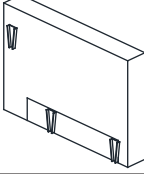
BOX 1 PARTS LIST

ITEM	DESCRIPTION	DRAWING	QTY
1	LEFT SIDE PANEL		1 PC
2	RIGHT SIDE PANEL		1 PC

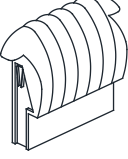
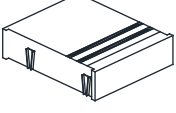
BOX 2 PARTS LIST

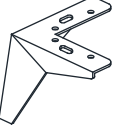
3	BACK REST		1 PC
4	SEAT FRAME		1 PC
5	CUSHION SEAT		1 PC
6	LEG		4 PCS

30023-1 SEATER ASSEMBLY INSTRUCTION

PARTS ' LOCATION

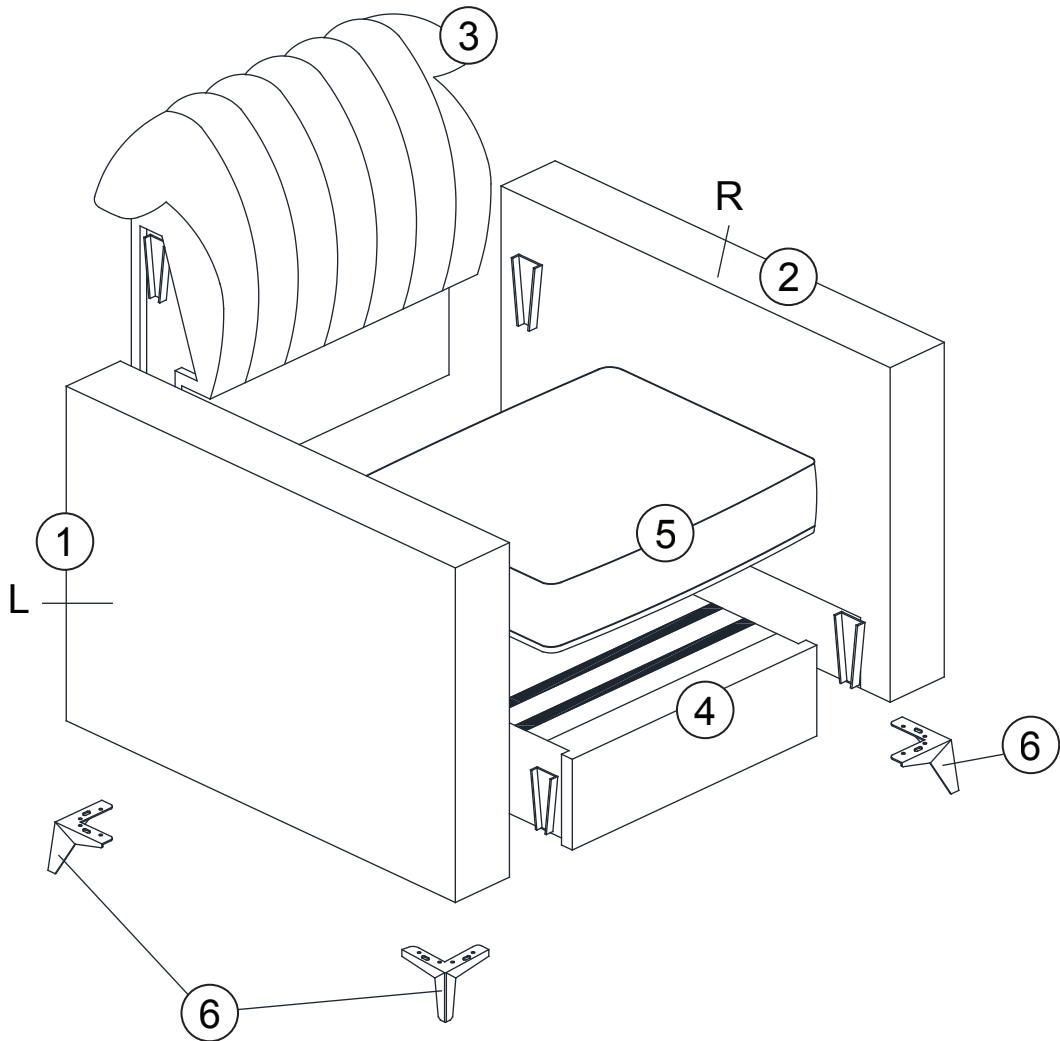

30023-1 SEATER ASSEMBLY INSTRUCTION

STEP 1

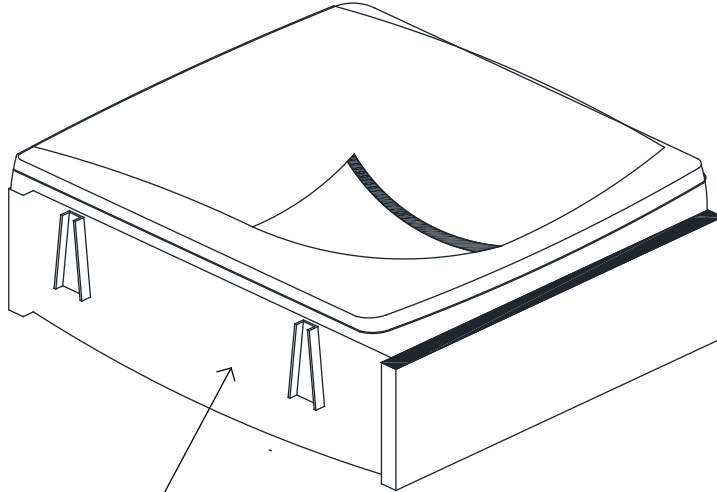

Get all others parts from compartment of seat frame.

STEP 2

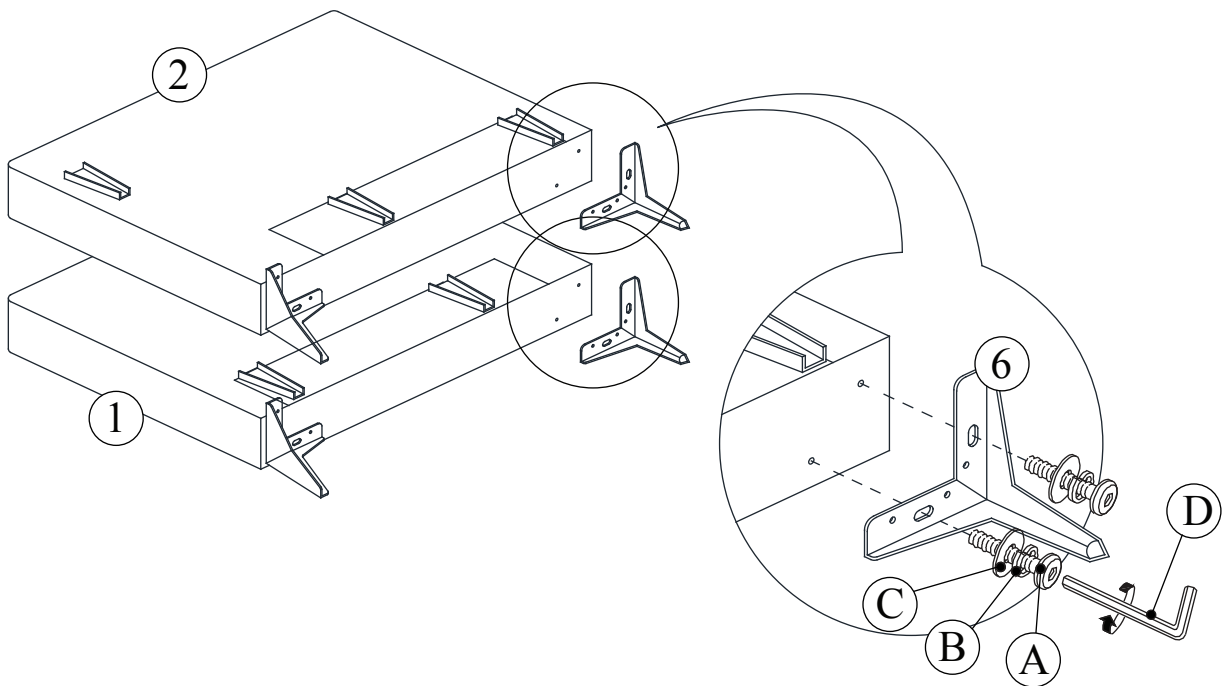

30023-1 SEATER ASSEMBLY INSTRUCTION

STEP 3

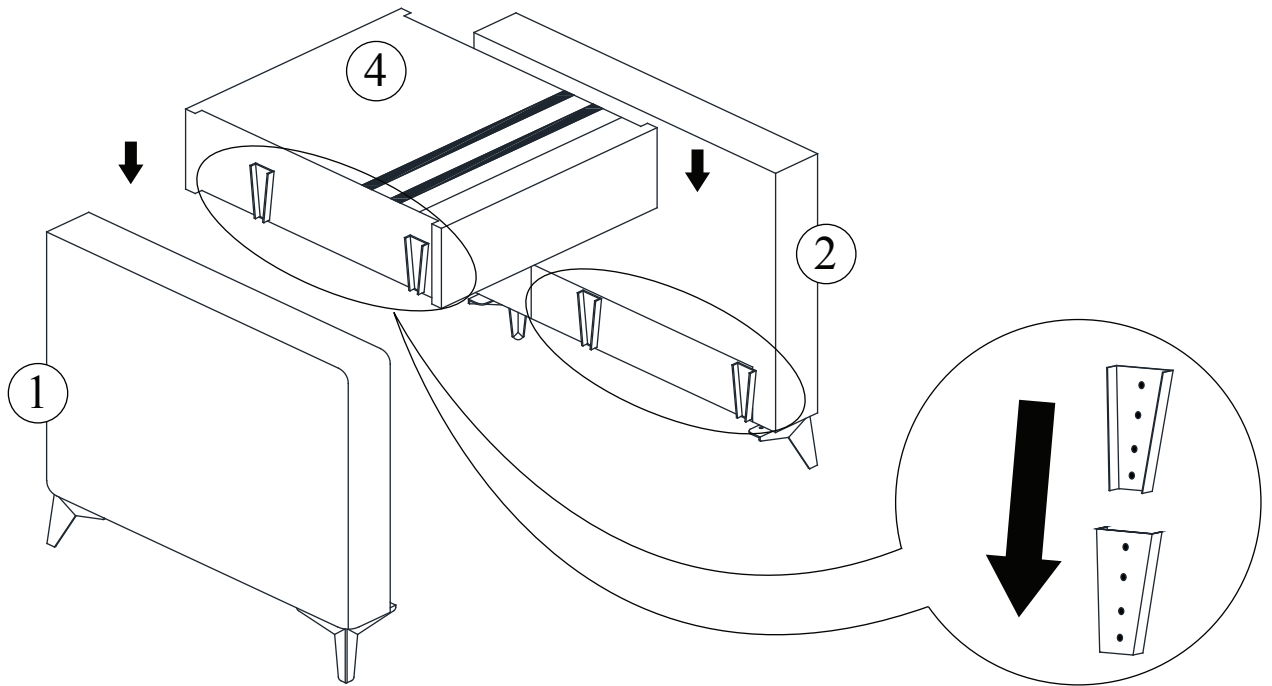

STEP 4

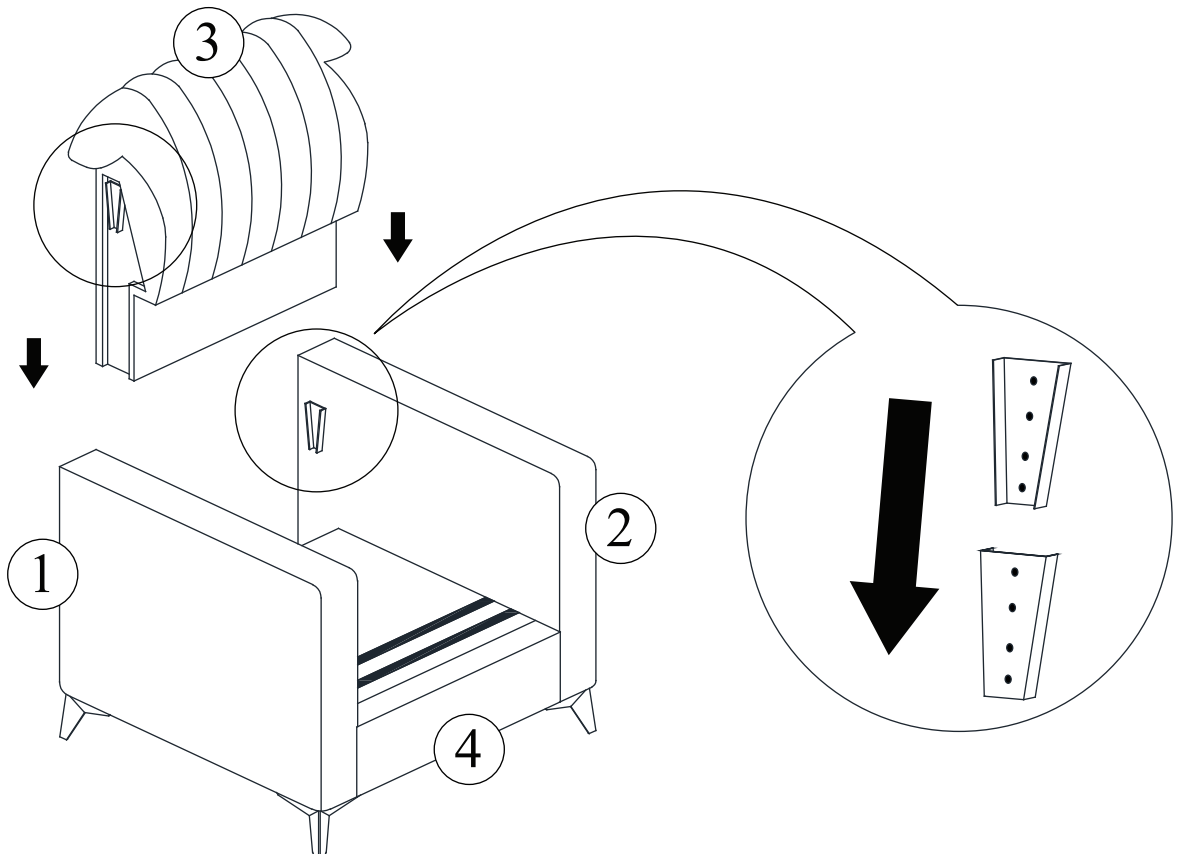

30023-1 SEATER ASSEMBLY INSTRUCTION

STEP 5

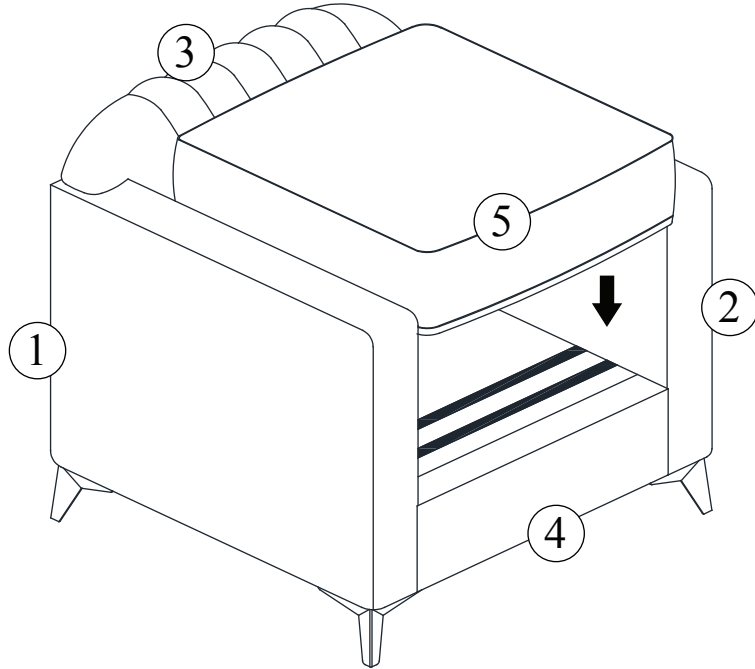

STEP 6

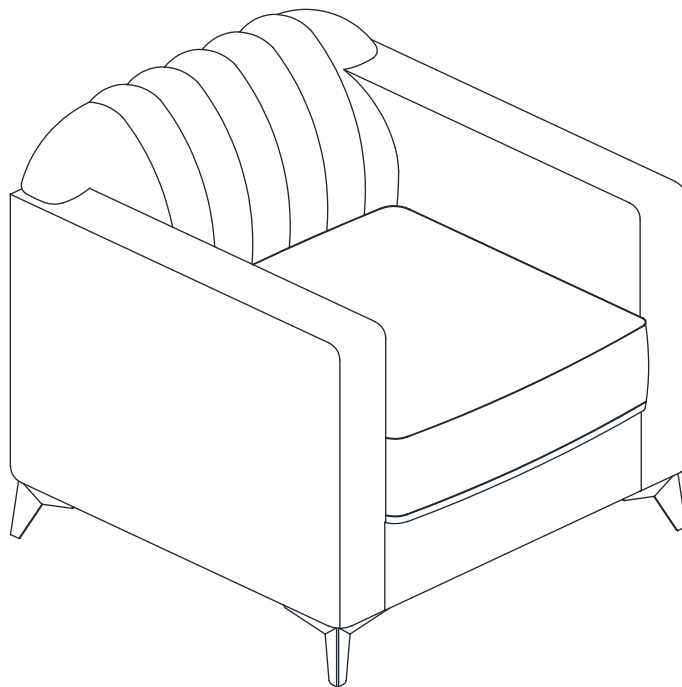

ASSEMBLY COMPLETED