



Owner's Manual

Raven Smoker

Bluetooth Version

110 ~ 120V – MODEL: BS1120BT

220 ~ 240V – MODEL: BS1120BTCE

Bradley Smoker Inc.

1-866-508-7514

support@bradleysmoker.com

www.bradleysmoker.com

Printed in China/ Imprimé en Chine/ Impreso en China/ Gedruckt in
China

May 2024/ Mai 2024/ Mayo 2024/ Kann 2024

Bradley Smoker™



Apps Name: Bradley Smoker iSmoke™



Dear Sir or Madam,

Revolutionary Smoking Technology for Household Chefs

Welcome to the wonderful experience of backyard smoking and slow-roast cooking. The Bradley Smoker™ is an insulated smoker oven designed to automatically generate a continuous flow of clean smoke. It is an outdoor electrical appliance that enables one to cook, roast, hot smoke, as well as cold smoke food (with the addition of ice) while consistently delivering superior results using minimal effort.

The Bradley Smoker™ is unique in that it produces smoke which is four times cleaner than traditional burn-box chips* or wood pellets. It automatically extinguishes the spent Bisquettes® which prevents the formation of high-temperature gases and acids. In addition, the Raven Smoker™ meets both North American and European appliance standards.

There are different woods of the Bradley Flavor Bisquettes® that are made especially for your smoker: Alder, Apple, Cherry, Hickory, Maple, Mesquite, Oak, Pecan, Special Blend, and Whiskey Oak. For recipe ideas, please have a look at the enclosed recipe booklet and on our website: www.bradleysmoker.com.

We also suggest you try our Bradley Recipe Collection, Sausage Hooks, Weather Guard Covers, and the Bradley Digital Thermometer with a meat probe that takes all the guesswork out of roasting and smoking meat.















I wish you great cooking and smoking for the years to come.

Sincerely,
Wade Bradley

A handwritten signature in black ink, appearing to read "Wade Bradley". The signature is fluid and cursive, with a large, sweeping flourish at the end.

**Based on studies and tests performed at The British Columbia Institute of Technology.*

Table of Contents

Safety		Page	5 – 7
General Maintenance		Page	8
External Components		Page	9
Cabinet Internal Components		Page	10
Assembly Instructions		Page	11
Seasoning Your Smoker		Page	12
Optimum Use Of Your Bradley Smoker™		Page	13
Touch Indicators Explained		Page	14
Display Panel Referenced		Page	15
Display Operation Explained		Page	16 - 22
Before You Call		Page	22
Troubleshooting		Page	23 - 24
Electrical Specifications		Page	25
Warning		Page	26
Warranty		Page	27-28

IMPORTANT SAFEGUARDS

When using electrical appliances, basic Safety precautions should always be followed including the following:

- **Read all instructions.**
- Carefully read through assembly instructions to prepare the smoker for use.
- **Do not** modify your smoker from its original state.
Modifying the appliance will nullify the warranty.
- For safe operation of the Bradley Electric Grill/Smoker, it is imperative to place the racks correctly. Failing to do so may result in the hot food items sliding out while removing them. Be sure to follow this guideline to avoid any potential hazards.
- This appliance can be operated by children aged 8 years and above and persons with reduced physical, sensory, or mental capabilities, or lack of experience and knowledge if they have been given supervision or instructions concerning the proper use of the appliance in a safe way and understand the hazards involved.
- Close supervision is necessary when any appliance is used by or near children. *Children should not play with the appliance.*
- **Children less than 8 years of age must be continuously supervised when around the appliance.**
- Cleaning and user maintenance should not be performed by children without supervision. **CAUTION — Some parts of this product can become very hot and cause burns. Particular attention has to be given where children and vulnerable people are present.**
- **Do not** operate any appliance with a damaged cord or plug or after the appliance malfunctions or has been damaged in any manner. Return the appliance to the nearest authorized service facility for examination, repair, or adjustment.
- **Do not** touch hot surfaces. Use handles or knobs.
- Unplug from the outlet when not in use and before cleaning. Allow to cool before putting on or taking off parts.
- **Do not** use accessory attachments that are not recommended by the manufacturer. Doing so may cause injuries.
- **DO NOT EXPOSE TO RAIN.**
- **Do not** let the cord hang over the edge of the table or counter, or touch hot surfaces.
- The cord should be arranged so that it will not drape over the countertop or tabletop where it can be pulled on by children or tripped over unintentionally.
- **Do not** place on or near a hot gas or electric burner, or in a heated oven.
- Extreme caution must be used when moving an appliance containing hot oil or other hot liquids.
- Always attach the plug to the appliance first, then plug the cord into the wall outlet. To disconnect, turn any controls to “OFF”, then remove the plug from the wall outlet.
- **Do not** use the appliance for other than intended use.
- **Do not** use any other type of wood other than Bradley Flavor Bisquettes®.
- Lift and move the Raven Smoker with care to prevent strains and back injuries.
- Use caution when reaching into or around the smoker.
- It is recommended that a fire extinguisher be placed near the smoker. Refer to your local authority to determine the proper size and type of fire extinguisher.
- If an extension cord is used, the marked electrical rating should be at least as great as the electrical rating of the appliance.
- If an extension cord is required, the cord must be an approved heavy-duty cord and not over 1.85 m (6 feet) long.

IMPORTANT SAFEGUARDS CONTINUE:

- Outdoor extension cords should be used with outdoor use products and are surface marked with the suffix letter “W” and with a tag stating, “Suitable for use with outdoor appliances”.
- **CAUTION: risk of electric shock. Keep the extension cord connection dry and off the ground.**
- To protect against electrical shock do not immerse cord, plugs, or appliances in water or other liquid.
- Properly dispose of all packaging.
- Use caution when assembling, operating, handling, or cleaning your smoker as some metal edges may be sharp.
- Use extreme caution when removing the tray or disposing of hot grease.
- **Do not** clean with metal scouring pads. Pieces can break off the pad and touch electrical parts causing a risk of electric shock.
- Oversize foods or metal utensils must not be inserted in appliances as they may create a fire or risk of electric shock.
- A fire may occur if the appliance is covered or touching flammable material, including curtains, draperies, walls, and the like, when in operation.
- **Do not** store any item on top of the appliance when in operation.
- Extreme caution should be exercised when using containers constructed of other than metal or glass.
- **Do not** store any materials, other than manufacturers recommended accessories, in this appliance when not in use.
- **Do not** place any of the following materials in the appliance: (paper, cardboard, plastic, and the like).
- **Do not** cover the crumb tray or any part of the oven with metal foil. This will cause overheating of the appliance.
- Turn off the appliance by pressing the Power switch at the back. *See page 11.*
- **Do not** operate any appliance with a damaged cord or plug or after the appliance malfunctions or has been damaged in any manner.

Carefully read through the Assembly Instructions to prepare your smoker for use on page 11

Power cord extension cable:

- A short power-supply cord is provided to reduce the risk resulting from becoming entangled in or tripping over a longer cord.
- If a longer extension cord is used:
 - A. The marked electrical rating of the extension cord should be at least as great as the electrical rating of the appliance.
 - B. The cord should be arranged so that it will not drape over the countertop or tabletop where it can be pulled on by children or tripped over unintentionally.
 - C. The cord set or extension cord should be a grounding-type 3-wire cord.
 - D. Extension cords are available and may be used if care is exercised in their use.

CAUTION:

- To ensure continued protection against the risk of electric shock, connect to properly grounded outlets only.
- Risk of Electric Shock. Keep the extension cord connection dry and off the ground.
- Preheating of the appliance is not necessary.

SAVE THESE INSTRUCTIONS

HOUSEHOLD USE ONLY/ OUTDOOR USE ONLY. DO NOT OPERATE IN AN ENCLOSED AREA

Carbon Monoxide Hazard Warning

- The use or combustion of Bradley Flavored Bisquettes® in this product could expose users to chemicals such as carbon monoxide. Unventilated use will increase the risk of serious health issues, up to and including death.
- This appliance has IPX0 moisture rating. To avoid electrical shock, it is required to be used outdoors only, while being sheltered and 10ft (3m) away from overhead construction, walls, or rails.
- Sheltered areas must be well-ventilated and protected from direct rain and wind.
- The Smoker must be placed on a hard level, non-combustible surface and away from any other combustible materials like roof overhangs and wall sidings.
- Care should be taken to avoid touching heating elements inside the oven.
- **WARNING: The appliance and its accessible parts may become hot during use. Young children should be kept away unless continuously supervised.**
- Cleaning and user maintenance should not be performed by children without supervision.
- **Do not** plug in the smoker until it is fully assembled.

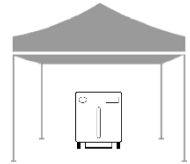

When in Use

- Use only approved grounded electrical outlets.
- Use only temperature probes supplied with this oven.

DO NOT LEAVE UNATTENDED

- **Do not** cover or seal the racks or drip tray with aluminum foil. This can cause severe damage to your smoker.
- **Do not** move the smoker when in use.
- **Do not** exceed an internal cabinet temperature of 160 °C (320 °F)
- Always wear oven mitts or gloves to protect your hands from burns. Do not wear loose clothing or allow hair to hang freely.
- **Do not** use the packaging box to cover the smoker.
- **Do not** allow rainwater or snow to encounter the smoker at any time.
- To avoid smoke and carbon monoxide poisoning, do not use the product indoors. Use in a well-ventilated area.
- To avoid an electric shock hazard, please use under a shelter or gazebo. Do not use it during an electrical storm or in windy conditions. Do not use it when raining or snowing.
- **Do not** use near flammable liquids, gasoline, gases, or where flammable vapours may be present.
- **Do not** immerse in water.

EMPTY THE WATER AND GREASE TRAY EVERY 2 TO 3 HOURS OF BURNT WOOD BISQUETTES® AND REFILL WITH FRESH WATER.

After Each Use

- Unplug the smoker when it is not in use. See the “Maintenance Procedures” section on page 8.
- Place extinguished Bradley Flavor Bisquettes® at a safe distance from all structures and combustible material.
- Store the smoker in a dry covered place, out of reach of children.
- Clean out any grease. Grease build-up may cause a fire.
- **Do not steam clean or power wash this appliance.**

GENERAL MAINTENANCE

Refer to the External Components List & Internal Components List Diagrams on Pages 9-10

Important Safety Precautions

- Use precautions during user maintenance.
- The Bradley Smoker™ must be maintained and cleaned after each use.
- Unplug the Long Power Cord from the wall outlet before starting any maintenance or cleaning.
- **Do not** immerse the smoker in water.
- **Do not** spray any kind of appliance cleaner inside of the smoker.
- **Do not** cover or seal the Racks or Drip Tray with aluminum foil, this can cause severe damage to your smoker.
- **Do not** leave unattended when in use.
- **Do not** spray or clean the smoker with excessive amounts of water. Instead, use a damp cloth.

Maintenance Procedures

- Unplug the Long Power Cord before removing the Bisquettes® dispenser from the Smoker.
- Use caution when handling and cleaning your smoker as some metal edges may be sharp.
- Clean out the Water Bowl. Dispose of all burnt Bisquettes® carefully as they may still be hot.
- Wash the Racks, Drip Tray, and water-renderings tray with hot water and dish detergent or put them in the dishwasher.
- Remove food particles and grease residue from the smoker. If the inside needs cleaning, wipe it with a damp cloth.

Note: The tower should have smoke or black residue on the inside. The more residue, the better the food will taste.

- The Bisquettes® dispenser should always be kept clean and free of wood chips and grease. If loose wood chips have collected in the Bisquettes® dispenser, simply vacuum these particles away.

Refer to “Quick Repairs” on pages 25-32 for removal of the bisquettes® dispenser.

- The Bisquettes® dispenser should be lightly scraped using a wire brush or scraper to remove any residue that has been left by the burning process.
- Clean the Damper (at the top of the Smoker) to ensure it is not stuck.
- Wipe the Door Seal with warm water and dish detergent to remove any leftover residues and food particles.
- Wipe the Meat probes with a warm damp towel to remove any leftover residues and food particles.

Note: The meat probes are not dishwasher safe.

After Cleaning

- Replace Racks, Drip Tray, and water-renderings tray into the smoker, making sure all parts are clean and dry.
- Insert the feeder tube back into the smoke door.
- Make sure the Power Cord is kept unplugged when the smoker is not being used.

EXTERNAL COMPONENTS

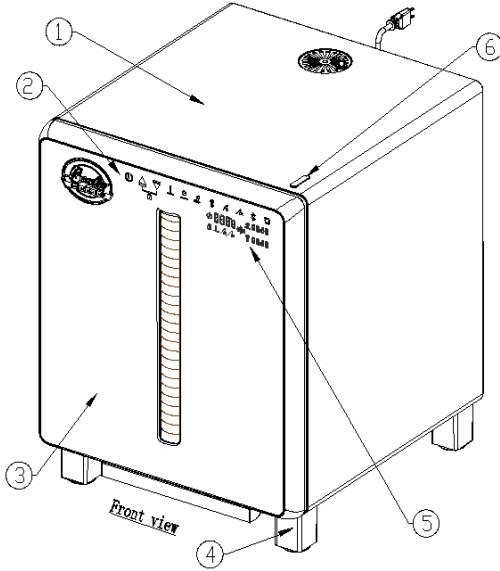

1. Smoker cabinet
2. Power Switch
3. Front door
4. Feet
5. Display panel.
6. Door adjustment holes

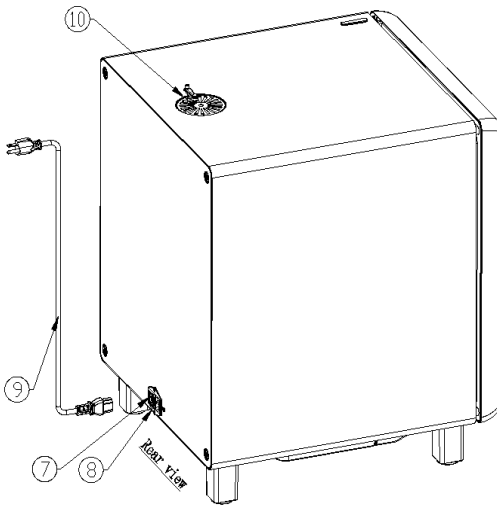

7. On/OFF switch
8. Power receptacle
9. Power cord
10. Chimney vent damper.
82. Fuse holder.
83. Fuse holder tab.

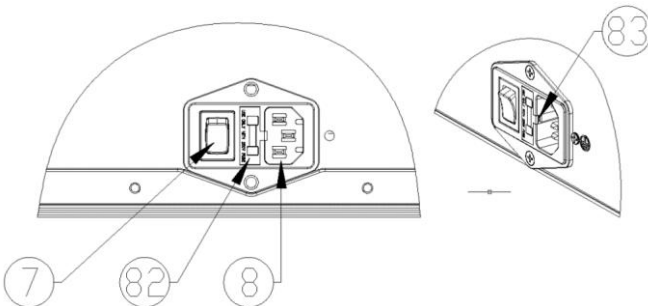

CABINET INTERNAL COMPONENTS

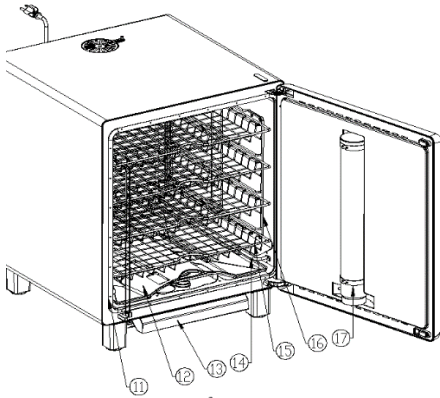

11. Door seal.
12. Drip tray.
13. Water/renderings tray.
14. Heating element (2 included).
15. Grill rack (4 included).
16. Shelving for grill rack.
17. Feeder tube.

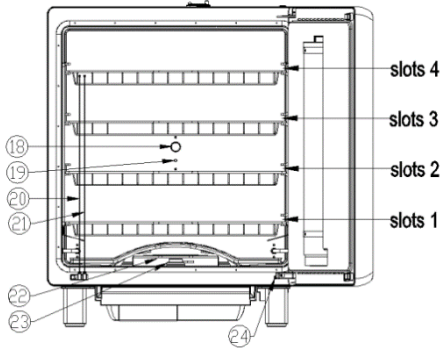

18. Temperature high limit.
19. Internal temperature sensor.
20. Meat probe 1.
21. Meat probe 2.
22. Smoke generator cover.
23. Smoke Generator.
24. Door switch.
25. Screws for feet.

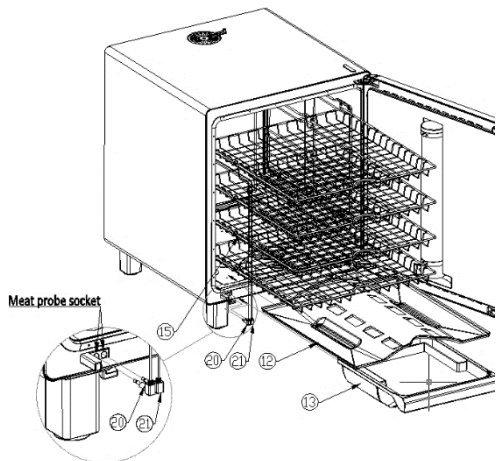
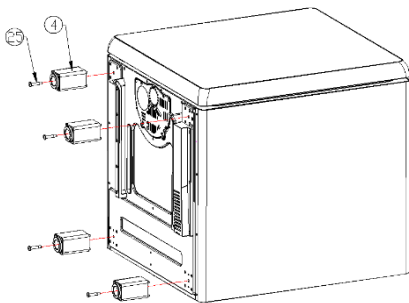

Proper usage of grill racks:

Grill racks are to be used in their designed holding slots (1-4) only as shown on the diagram. If grill racks are inserted improperly, they will not be secured properly, and hot racks may cause serious injuries.

ASSEMBLY INSTRUCTIONS

How to assemble your 4 Rack Bradley BS1120BT (CE) Bradley Raven smoker

- Remove the smoker from the box.
- Take all packaged parts out of the smoker.
- Remove all protective packaging materials from parts.
- Set the smoker on a firm base, stand, or on a table.
- Open the cabinet door and remove all the internal protective packaging materials. Untie the plastic holding the grill racks from the rack shelves.
- Remove all the racks, drip tray, oil drip tray, water-oil bowl, meat probe, and power cord. Clean the cabinet from remaining plastic residues.
- Take the 4 screws (25) out of the small plastic bag to install the feet (4).
- Install components (12), (13), (15), (20), and (21) when the plastic and packaging have been removed and the cabinet has been cleaned of debris.

Handling of Packaging

All packaging should be discarded as per the regulations in your area.
The packaging box should not be used as a cover when the smoker is in use.

Electrical Connection Set-Up in this order

1. Plug the supplied power cord into the back of the smoker socket (8).
2. Plug the other end of the power cord into the wall socket.
3. Turn on the main power using the **ON/OFF** switch (7).

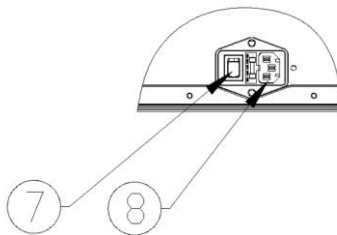

CAUTION

TO ENSURE CONTINUED PROTECTION AGAINST THE RISK OF ELECTRICAL SHOCK CONNECT TO A PROPERLY GROUNDED OUTLET ONLY.

CAUTION

DISCONNECT FROM THE POWER OUTLET BEFORE CLEANING OR SERVICING.
DO NOT IMMERSE IN WATER / DO NOT EXPOSE TO RAIN.

This device complies with Industry Canada license-exempt RRS standard(s). Operation is subject to the following two conditions: (1) this device may not cause interference and (2) this device must accept any interference, including interference that may cause undesired operation of the device.

SEASONING YOUR SMOKER

Seasoning the Bradley Smoker™ is an ongoing process, the more you use your smoker, the better tasting your foods will be. Seasoning is mainly to remove the impartial smells from your smoker. The smell of your new Bradley Smoker™ is not necessarily how you want your food to taste.

Seasoning Method:

- Wash your food racks (15), drip tray (12), and water/renderings tray (13) and place them back in the smoker.
- Fill the Water/renderings tray with water. *Do not exceed the fill level marker.*
- Open the door and fill the feeder tube with 6 Bradley Flavor Bisquettes®.
- Plug the power cord into the back of the smoker.
- Plug the other end of the cord into its own designated outlet.
- Turn on the ON/OFF switch (7) located at the bottom right corner at the back of the smoker.
- On the main display, choose the appropriate smoke time, cook time, and temperature settings.
*** Your Smoker will be seasoned having reached 66°C (150°F) and smoked for 2 hours or until Bradley Flavor Bisquettes® are out.*
- When seasoning has been completed, discard the burnt bisquettes®.
- *You are now ready to use your smoker.*

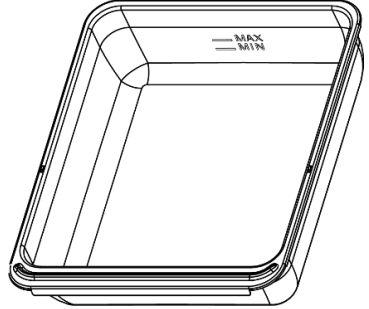

***Refer to the display controls on pages 11-19.*

OPERATING GUIDELINES

Getting started

- After seasoning, empty and refill the water/renderings tray with water.
- Place your food onto the cooking racks and load them into the smoker.
- Set the vent damper at the desired opening. *Do not close the damper all the way when the smoke is running, it may result in heavy condensation.*
- Turn ON the Smoker by pressing the power switch.
(please refer to display controls on pages 16-22)
- Choose your desired temperatures and cook times.

Note: To get a more accurate temperature of the food being smoked, use the meat probes. Keep in mind that the outside temperature and wind will affect the cooking temperature of the smoker.

“Remember to clean your smoker after each use.”

How to do a Cold Smoke:

- Use the smoke option only.
- Do not turn on the cabinet heat.
- Open the damper to its maximum open position.

OPTIMUM USE OF YOUR BRADLEY SMOKER™

Bradley Smoker™ is specifically designed to cook food at a low and slow temperature. By using this method, you will end up with a better taste and aroma. So, take your time to plan your cooking process, and let the Bradley Electric Grill/Smoker work its magic to create a mouth-watering smoked dish.

Do not overfill your racks – always leave space to allow for constant airflow, otherwise, smoke will be trapped and won't circulate through the entirety of your unit.

To evenly cook or smoke food it is recommended to move racks up and down.

Smoking times and temperature will vary based on the following conditions:

- Ambient air temperature.
- Amount of product in the smoker.
- Internal temperature of the product being smoked.
- *Displayed temperature readings are for reference only.*

NEVER fully close your smoker vent, it may result in heavy internal condensation.

- Empty and refill your water bowl every 2-3 hours.
- When cooking or smoking foods that are heavy with grease and fat, please place an aluminum pan on the rack below the food to catch as much of the rendering as possible. This will help to keep your Bradley Smoker™ clean and will extend the life of your smoker. It will also help to prevent the possibility of a grease fire.
- Do not let the food touch the walls of the smoker.
- Always keep your smoker clean to increase the longevity of your unit. From time to time scrape the bisquettes® burner clean of any residue buildup to maintain a clean and even surface for the bisquettes®.
- Use a weather guard cover to protect the smoker from the elements of weather.
Disclaimer: Weather guards are not for waterproofing.

Note: Meat probe cables are not dishwasher safe.

****Do not submerge the cables or connecting ends into water or liquid of any sort, this will cause permanent damage.**

TOUCH INDICATORS EXPLAINED



Power Switch



**Up and Down Adjustment
Switch and Child Lock**



**Cook Temperature
Switch**



Cook Timer Switch



**Bisquettes®
Advance Timer
Switch**



Smoker Timer Switch



**Meat Probe 1
Temperature Alert
Switch**



**Meat Probe 2
Temperature Alert
Switch**



Bluetooth Switch



**F / C Unit Exchange
Switch**

DISPLAY PANEL REFERENCED

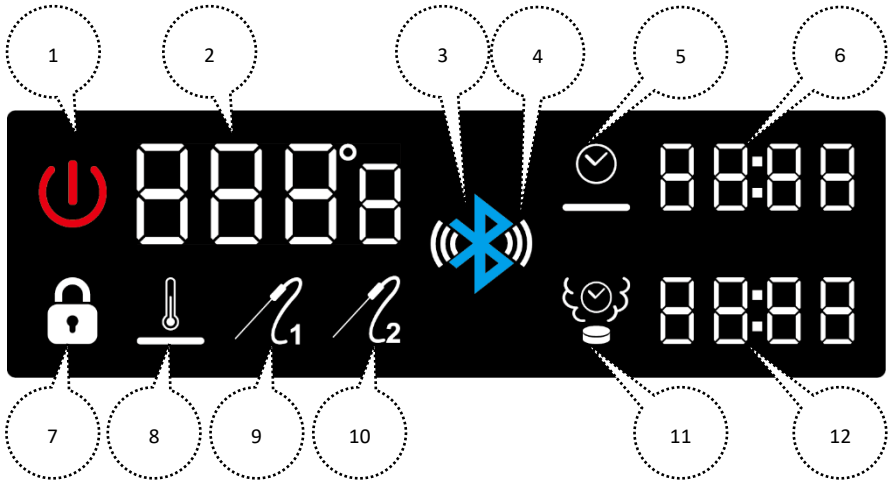

- | | |
|-----------------------|----------------------------------------------------------|
| 1. POWER | When power has been turned on this icon will be lit. |
| 2. TEMPERATURE | Displays cabinet and meat probe temperature. |
| 3. BLUETOOTH | When Bluetooth is turned on this icon will be lit. |
| 4. SIGNAL | When Bluetooth is connected this icon will be lit. |
| 5. COOK TIMER | Cook time icon. |
| 6. COOK TIME | Cook time display. |
| 7. CHILD LOCK | When the child lock is activated, this icon will be lit. |
| 8. TEMPERATURE | Temperature icon. |
| 9. MEAT PROBE 1 | Meat probe 1 alert selection indicator. |
| 10. MEAT PROBE 2 | Meat probe 2 alert selection indicator. |
| 11. BISQUETTES® TIMER | Bisquettes® advancement timer icon. |
| 12. SMOKE TIMER | Smoke time display. |

DISPLAY OPERATIONS EXPLAINED

Powering On / OFF the Unit



Press the POWER Switch to turn ON / OFF the smoke.



When powering the smoker ON, the sound will beep once, and the power indication light will turn red. The entire display panel will turn on for self-check. After 5 sec, the display panel will show the cabinet's internal temperature and the temperature icon will turn on.



**Note: The display shows "OPEN" when the door is in an open state.*



Bluetooth Pairing



Press the Bluetooth switch to turn on the Bluetooth power to prepare pairing with a Smart Device. *(Bluetooth needs to be activated on your smart device first)*



The Bluetooth starts broadcasting the smoker's name for smart devices *(visible only on smart devices)* and the Bluetooth icon will turn on.



When the smoker receives the smart device ID for pairing, the Bluetooth broadcasting signal icon will flash.



Press the Bluetooth switch to pair the smart device. After the smart device pairs, the Bluetooth icon light and signal indicator will stay on.



Press and hold the Bluetooth switch for 3 seconds to disconnect and power to the Bluetooth. The Bluetooth icon light and the signal indicator will turn off.



Notes:

1. After the Bluetooth is paired, you can use the App to turn On / Off and control all functions of the unit. Smoker needs to be set up and initiated first before the App can take control. This means that you can not start the smoking process from the App itself.
2. When the smart device is out of range, the Bluetooth broadcasting signal icon will start flashing, and the Bluetooth icon will stay on. When the smart device is back in range it will automatically connect and the Bluetooth broadcasting signal icon will stay on.

Bluetooth pairing notes section.

Notes:

1. Only one smart device can be connected to the smoker at a time.
2. When the main power switch (7) page 8, has been turned off, the smart device ID will be erased from the smoker memory. A new pairing connection must be initiated when powering the unit back ON again.
3. The smart device will reconnect when the App has been relaunched or when the smoker has been turned OFF/ON from the touch indicator .

Cook Temperature Parameter Settings



Press the Cook Temperature Switch, the cook temperature icon light and temperature digits will be flashing. The display will show the default set-point temperature of 100°C or the previously set temperature value.



When turning on the Cook Temperature setting, the Cook timer will turn on at the same time. The default timer is 5:00hrs.



Press the up and down switch to adjust the cooking temperature. The cooking temperature flashes during the setup.



Press the Cook Temperature to switch to confirm the settings, alternatively, wait for 3 seconds and the cook temperature will auto-set.



Hold the Cook Temperature switch for 3 seconds, and the cook temperature function and the cook icon light will turn off. The temperature digits will display the cabinet's internal temperature.



Default temperature: 100°C / 212°F

Temperature adjustment range: 30 - 160°C / 86 - 320°F

Note: When the outside operating temperature is below -10°C / 14°F, the word COLD will be displayed and no operation shall be conducted on the unit until the temperature warms up.

Note: When the internal temperature reaches past 180°C / 360°F, the buzzer will sound, ERR4 will be displayed and the smoker will turn off automatically.

Cook Timer Parameter Settings



Press the Cook Timer switch.

The cook timer icon light turns On and timer digits will be flashing. Flashing digits on the display will show the default timer of 05:00 or the previously set timer value.



Press the up and down switch to adjust the cook timer.



Press the Cook Timer Switch to confirm settings, alternatively, wait for 5 seconds. The Cook Timer icon and digits will stay on and the timer will start to count down.



Hold the Cook Timer switch for 3 seconds, and the Cook Timer function and icon light will turn off. The temperature digits will display the cabinet's internal temperature.



Default Timer: 5:00

Timer adjustment range: 00:00 – 10:00

Timer adjustment increment: 1 min

Note:

If the cook function is turned on and the cook timer is not set, it will default to 5 hours, however, it will not show the countdown on the cook timer display.

Bisquettes® Advancement and Smoke Timer Settings

Bisquettes® advancing timer can be selected at 20, 30, or 40-minute intervals. First, you have to select the interval increment and then set the total smoking time.



Press the Bisquettes® Advance Timer switch and then press to select the timing of 20, 30, or 40 min.



****Default Bisquettes® Advance timer is 20 min.**



Next, press the Smoke Timer switch.

The Smoke Timer icon light turns ON and the timer digits will be flashing. The display will show the default timer of 20 min or the previously set timer value.



Press the up and down switch to adjust the total Smoke time.



Press the Smoke Timer switch to confirm settings, alternatively, wait for 5 seconds and the timer will set. When set, the Smoke Timer icon and digits will stay on, and the Smoke Timer will start to count down



To turn the timer off, hold the Smoke Timer switch for 3 seconds, and the Smoke Timer function and icon light will turn off. The temperature digits will display the cabinet's internal temperature.



Default Smoke Timer: 00:20

Smoke Timer Adjustment Range: 0:20 – 9:00

Smoke time adjustment depends on the Bisquettes® advance setting of 20,30 or 40 minutes.

NOTE:

Bisquettes® timer advancement can not be changed during the smoking time.

The smoking process must be canceled before a new advancement time can be set.

Meat Probe 1 and 2 Temperature Alert Settings



Press the Meat Probe Temperature alert switch.

The Meat Probe icon light and temperature digits will be flashing. The display will show the default temperature of 50°C or previously set temperature value.

Press the Meat Probe Temperature alert switch once. It will display the meat's existing internal temperature.

Press the Meat Probe Temperature alert switch twice, it will display the meat probe set target temperature.



Press the up and down switch to adjust the parameter of the meat probe alert temperature.



Press the Meat Probe Temperature alert switch to confirm the settings, alternatively wait for 5 seconds and the timer will set. Temperature digits will display the cabinet's internal temperature and the probe icon will stay lit.



When the meat's internal temperature reaches the target set point, the meat probe icon and temperature digits start flashing, the buzzer will sound, and temperature digits will display the target setpoint alert temperature.



To stop the buzzer, press the Meat Probe Temperature alert switch. The Meat Probe icon light and temperature digits will stop flashing and the digits will display the internal temperature of the cabinet



Hold the Meat Probe Temperature alert switch for 3 seconds, the alert function and icon light will turn off. The temperature digits will display the cabinet's internal temperature.



Default Temperature: Probe surrounding temperature is displayed.

Displayed temperature Range: 0 - 100°C / 32 - 212°F

Adjustable Alert Range: 5 - 100°C / 41 - 212°F

Adjustment increment: 1°C / 1 or 2°F

Temperature Unit Exchange Settings



Press the Temperature Unit Exchange Switch to change from C to F.



Activating The Child Lock



Press both the up and down switch at the same time to enable or disable the Child Lock.



When the smoker is turned on from the power indicator and there is no operation detected on the control panel after 5 minutes, the child lock will automatically be activated.

Custom Recipe Sequence Program

When the Custom Recipe Sequence menu is activated from the smart device, the display will indicate APPs and Prog. Selected programs from 01 to 50 will be displayed and activated.



When the Custom Recipe Sequence program has been completed, the digits display End, and a buzzer will sound for 3 minutes.



Press any button to cancel the alarm and the Digital LED display will show the internal temperature.



Cancel all previous operations and settings.



When the Machine is on standby mode, holding down the Up switch and Bluetooth Switch at the same time for 3 seconds will reset all the smoker settings.

This means that Bluetooth needs to be paired again

Spin Arm Reset

In the case of an abnormal shutdown or power failure, the spin arm may not reset automatically. This abnormal situation can occur when the spin arm is in the process of advancing the Bisquettes® and power failure strikes. Upon restoring the power manual reset must be used.

When the spin arm stops at the auto-reset angle, the restart automatically resets to its standby stop position. No action is needed.

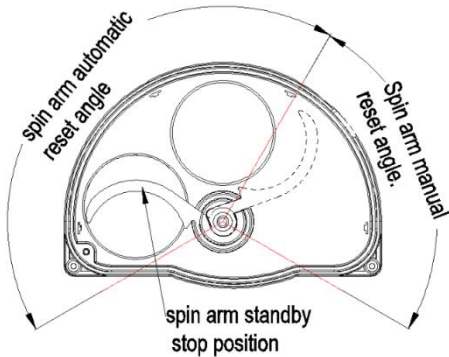

If the spin arm is out of the auto-reset angle area, a manual reset is required.

When the machine is on standby mode. To manually reset the spin arm press and hold the Temperature Unit Exchange Switch, it will have sound twice and the arm will auto return to the standby position. If the arm cannot reach to standby position. it can repeat the above action until the arm returns to the standby stop position.



Hold the Temperature Unit Exchange Switch for 5 seconds, it will reset the spin arm to the standby stop position.

BEFORE YOU CALL

Before Calling Customer Service, please visit our Bradley Support page at:
<https://www.bradleymoker.com/product/.....>(scroll to the support tab)

Read this manual for troubleshooting information. Refer to the “Warranty” page for more information.











To reach a service representative, please be prepared with the model number and serial number before calling. The model and serial number can be found on the shipping box, at the front of the manual, or on the back of the smoker cabinet.

We realize that you have made a considerable investment, and we are dedicated to supporting you and your smoker so that you have many years of creative smoking. Please do not hesitate to contact our customer support if you have any questions or in the unlikely event that your Bradley Smoker™ needs service. We are ready to assist you.



Please retain your original receipt or invoice for warranty validation if service is needed. For warranty and customer service, please email support@bradleymoker.com or contact your local distributor.

TROUBLESHOOTING-----ERROR CODES

To better help you with troubleshooting, your smoker has a built-in messaging system displaying the probable cause of error codes.

App Message	Alarm on smoker	Cancel Alarm	Error Code displayed	Conditions
Heating Element Failure	Buzzer sounds, flashing display code <u>Err1</u>	Press Any Key		<ol style="list-style-type: none"> 1. When the system detects no current drawn by the element 2. The oven heater or fuse is burnt, or the heating circuit fails.
Bisquettes® Burner Failure	Buzzer Sounds, flashing display Code <u>Err2</u>	Press Any Key		<ol style="list-style-type: none"> 1. When the temperature of the Bisquettes® burner is lower than the factory setpoint 2. Bisquettes® heater or fuse is burnt, or the heating circuit fails.
Bisquettes® Jammed	Buzzer sounds, flashing display_ <u>Err3</u>	Press Any Key		The motor rotation has not been detected within 60 sec
The Oven Is Too Hot!	Buzzer sounds, flashing display code <u>Err4</u>	Press Any Key		The cabinet sensor has detected the temperatures that are past the safety zone of 180°C /356°F
Cabinet NTC Sensor Failure	Buzzer sounds, flashing display code <u>Err5</u>	Press Any Key		Cabinet NTC sensor - open circuit or short circuit alarm.
Bisquettes® PT1000B Sensor Failure	Buzzer sounds, flashing display code <u>Err6</u>	Press Any Key		Bisquettes® burner sensor failure - open circuit or short circuit.
Meat Probe 1 Not Connected	Buzzer sounds, flashing display code <u>Err7</u>	Press Any Key		Meat Probe 1 is not connected properly.
Meat Probe 2 Not Connected	Buzzer sounds, flashing display code <u>Err8</u>	Press Any Key		Meat Probe 2 is not connected properly.
Meat Probe 1 Failure	Buzzer sounds, flashing display code <u>Err9</u>	Press Any Key		<p>This alarm is triggered when the probe temperature is out of its regular range of 382F / 194C.</p> <p>Note: <i>the operating temperature is between 32-212F / 0-100C</i></p>
Meat Probe 2 Failure	Buzzer sounds, flashing display code <u>Err0</u>	Press Any Key		<p>This alarm is triggered when the probe temperature is out of its regular range of 382F / 194C.</p> <p>Note: <i>the operating temperature is between 32-212F / 0-100C</i></p>

Message Code

App Message	Alarm on smoker	Cancel Alarm	Error Code displayed	Conditions
Door Open	Buzzer Sounds for 5 sec. OPEn displayed.	Close the door		The door is open when the machine is Powered on. Note: when the door is open all the functions will be disabled.
Cold, Temp. under -10°C/ 14°F	Buzzer Sounds, Cold displayed All Functions are disabled	Turn the Power Switch Off		The Oven temperature sensor detects a temperature below - 10°C/14°F
Bisquettes® Feeding	No, Alarm	After feeding completed		The Bisquettes® feeding. Note: do not open the door, it will affect the Bisquettes® feeding.
<p>Remark: When the error codes “Err7”, Err8”, Err9”, and Err0” alarm occur, press any key to reset the error code and alarm sound. The machine will keep running. Unless press the defect Meat probe 1 or Meat probe 2 key, the error code and alarm will occur again. Press any key to reset the error code and alarm sound.</p>				

Only an authorized technician may work on electrical repairs on this appliance. Bradley Smoker Inc. accepts no responsibility for any malfunction or damage which is caused by unsuitable electrical repairs.

Your Notes:

Correct Disposal of this product



This marking indicates that this product should not be disposed of with other household wastes throughout the EU. To prevent possible harm to the environment or human health from uncontrolled waste disposal, recycle it responsibly to promote the sustainable reuse of material resources. To return your used device, please use the return and collection systems or contact the retailer where the product was purchased. They can take this product for environmentally safe recycling.

ELECTRICAL SPECIFICATIONS

	North America	Europe, GS, CE, and CB
Model:	BS1120BT	BS1120BTCE
Rated Voltage	110 ~ 120V	220 ~ 240V
Rated Frequency	50 / 60 Hz	
Rated Power	~1005-1200W	~1005-1200W
Cooking heating element	1000W (2pcs x 500W)	
Bisquettes[®] burner	100-300W	100-300W

CAPACITIES

Total Internal Volume	100 L
Smoking area volume	87 L
Cooking area	450X413X474mm
Rack Capacity	18.5 L x 4
Total racks	4 rack capacity (4 Racks included)
Rack Size	438X469X28mm

OPERATING SPECIFICATIONS

Cook time specifications:

Cook time adjustable range	0 min – 10 hrs.
Cook time adjustable increments	1 min

Smoke time specifications:

Smoke time adjustable range	00:20 min – 9:00 hrs
Bisquettes[®] burner adjustable increments	20/30/40 min

Operating temperature specifications:

Outside temperature operating range	-10 + 2°C ~ 50 + 2°C / 14°F ~ 122°F
Internal operating temperature range	30-160°C / 86-320°F
Internal adjustable temperature increments	1°C / 1 or 2°F

Warning:

**COLD will be displayed on the display panel when the temperature drops below -10°C/14°F.
Do not operate outside of these parameters – permanent damage can occur on display.**

Meat Probe operating specifications:

Adjustable meat temperature range	5-100°C / 41-212°F
Adjustable range increments	1°C / 1 or 2°F

Note:

**Meat probes are not dishwasher safe.
For best practices leave the probes connected at all times**

Warning!

Warning: Changes or modifications to this unit, not expressly approved by the party responsible for compliance, could void the user's authority to operate the equipment.

Note: This equipment has been tested and found to comply with the limits for a Class B digital device, pursuant to part 15 of the FCC Rules. These limits are designed to provide reasonable protection against harmful interference in a residential installation. This equipment generates, uses, and can radiate radio frequency energy and if not installed and used in accordance with the instructions, may cause harmful interference to radio communications. However, there is no guarantee that interference will not occur in a particular installation. If this equipment does cause harmful interference to radio or television reception, which can be determined by turning the equipment off and on, the user is encouraged to try to correct the interference by one or more of the following measures:

- Reorient or relocate the receiving antenna.
- Increase the separation between the equipment and receiver.
- Connect the equipment to an outlet on a circuit different from that to which the receiver is connected.
- Consult the dealer or an experienced radio/TV technician for help.

This device contains license-exempt transmitter(s)/receiver(s) that comply with Innovation, Science and Economic Development Canada's license-exempt RSS(s). Operation is subject to the following two conditions:

- (1) This device may not cause interference.
- (2) This device must accept any interference, including interference that may cause undesired operation of the device.

L'émetteur/récepteur exempt de licence contenu dans le présent appareil est conforme aux CNR d'Innovation, Sciences et Développement économique Canada applicables aux appareils radio exempts de licence. L'exploitation est autorisée aux deux conditions suivantes :

- 1) L'appareil ne doit pas produire de brouillage;
- 2) L'appareil doit accepter tout brouillage radioélectrique subi, même si le brouillage est susceptible d'en compromettre le fonctionnement.

WARRANTY

Limited Warranty

The Bradley Smoker is covered by a 1-year limited warranty against manufacturing defects. This warranty policy is applicable from the date of purchase and covers any material and workmanship defects from the manufacturer, provided that the product has been properly assembled, used normally, and maintained as per the recommended guidelines. It is advised to keep the sales receipt as proof of purchase date so that you can claim warranty benefits.

Requirements and Limitations

- This limited warranty is non-transferable, is valid only in the country of purchase and become void if the product is used for commercial or rental purposes.
- The warranty for Bradley Smoker Inc. is limited to repairing or replacing parts that are deemed defective by the company. If any component is found to be defective, Bradley Smoker Inc. will provide a replacement part at its discretion. Bradley Smoker Inc. will not be responsible for any reassembly.
- Shipping and handling charges are the responsibility of the original consumer/purchaser for all out-of-warranty parts ordered.
- The serial number of the Bradley Smoker must be provided on all warranty claims.
- This limited warranty will not provide any reimbursement for inconvenience, food, personal injury, or property damage.

Modifications to the original Bradley Smoker components or condition will nullify this warranty.

Warranty Exclusions

- Bradley Smoker Inc.'s limited warranty does not cover:
- Defects and damage resulting from improper assembly and installation, accidents, abuse, misuse, alteration, and vandalism.
- Damage resulting from weather conditions including but not limited to hail, hurricanes, tornados, earthquakes, wind, rain, or snow.
- Normal wear and tear, chipping, and scratching on surface finishes.
- Discoloration from exposure to sunlight, heat, or chemicals.
- Failure to perform regular maintenance, safety checks, and service including but not limited to; removal of grease build-up resulting in a flash fire, or damage caused by grease fires.

How to get warranty service

Prior to providing warranty service, Bradley Smoker Inc. or its agents may require you to provide (i) proof of purchase, and (ii) the serial number of the Product.

- Before starting the warranty process, please use the troubleshooting tips included in this manual
- If the troubleshooting tips do not resolve your problem, then contact customer support at support@bradleysmoker.com

It is recommended that you register your Bradley Smoker online at: www.bradleysmoker.com/pages/register-your-smoker

Registering your Bradley Smoker will provide you with quicker service and better support. You will also be able to receive important product support alerts.