

HCK

HOW COOL IS THAT?!

C150-SD

5.12 cu. ft. Built-in Single Door Outdoor Fridge



Designed for Stylish Outdoor Entertaining

Introducing our resilient, single door, outdoor fridge, built to withstand the toughest weather conditions, from rain and high temperatures to high humidity. With a weatherproof mechanism designed to handle sudden showers, it's tailored to tropical climates and suitable for all markets. Its versatile front venting design accommodates both built-in and free-standing installations, ideal for both commercial and residential settings. Plus, enjoy added convenience with lighting that turns on upon door open and an audible door alarm for peace of mind.

AVAILABLE COLORS/OPTIONS

**Seamless
Stainless Steel**

Features and Benefits

Free-standing and built-in design	Versatile installation options, combine aesthetics and functionality to suit various space requirements.
430 seamless stainless steel cabinet and door with stylish 3D metal logo and rounded corner metal handle	Sleek design and luxurious finish is enhanced by a strong corrosion resistance, ensuring the product remains durable, attractive and performs well over time.
Anti-vibration system	Quiet operation creates a peaceful environment.
Modern black metal interior	Offers sleek style, elevating any space with sophistication and contemporary feel.
Sliding/removable shelves	Provide easy access to items at the back, simplifying organization and retrieval for improved storage efficiency.
Reversible door	Offers flexible installation options for convenient use and maximizing space utilization in any layout.
Matching black aluminum shelf	Adds a cohesive touch to the design, offering a durable storage solution that enhances the space's aesthetic.
Door open alarm	Alerts you promptly to prevent unauthorized access or energy waste when a door is left open.
Digital controller	Allows precise temperature control and ease of adjustment and monitoring.
LED lighting	Find your drink fast with an efficiently illuminated interior.
Large storage capacity	Spacious 5.12 cubic feet of storage capacity that holds up to 161 standard 12 oz. cans.
Warranty	1 year parts and labor.
Temperature range	32°F to 72°F accommodates various storage needs, providing an ideal environment for your items.
ETL Sanitation certified for safety	Guarantees safety and reliability for peace of mind.

5.12 cu. ft. Built-in Single Door Outdoor Fridge

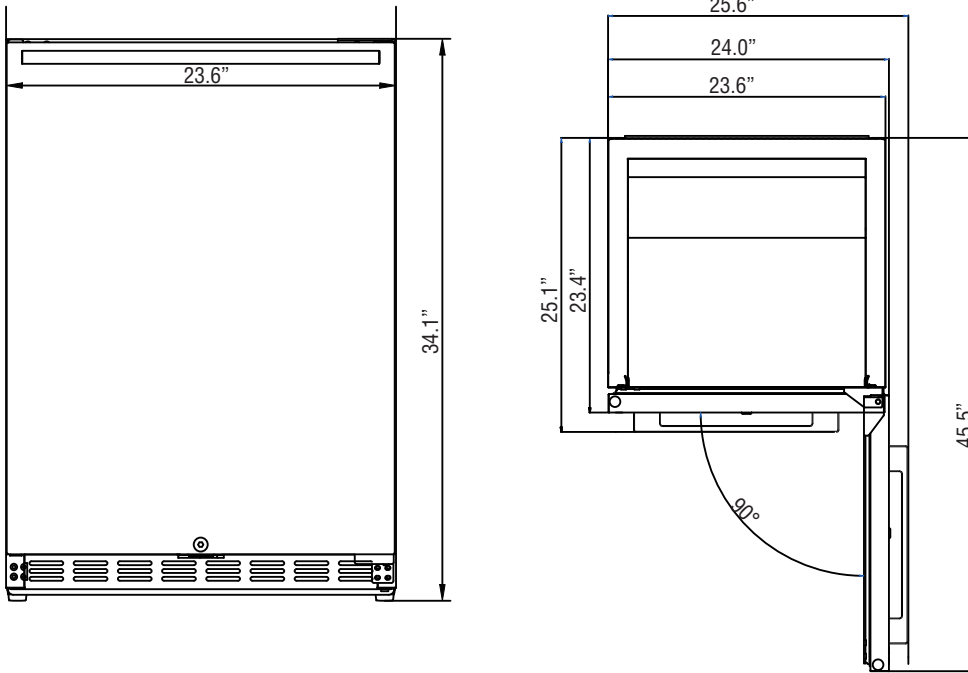

Specifications

Dimensions W x D x H	23.6 × 23.6 × 34.1"	Noise Level	45dB
Climate Rating	Tropic	Compressor	Constant speed
Cooling System	Dynamic	Refrigerant type	R600a
Control System	Electronic	Glass Shelves	0
Power Supply	110V / 60Hz / 1.3A	Wine/Bottle Shelf	3
Total Net Volume	5.12 cubic feet	Door Shelves	0
Fresh Food Net Volume	5.12 cubic feet	Crispers	0
Freezer Food Net Volume	0	Annual Energy Consumption	237 kWh / year
Electrical Cord Length	5.9 feet	Temperature Range	32°F to 72°F
Net Weight	80lbs		

HCK is a leading provider of premium refrigeration solutions, specializing in Beverage Fridges, Retro Fridges, Outdoor Refrigerators, Wine Coolers, Ice Makers and Kegerators. Their products seamlessly blend stunning design with cutting-edge technology, catering to both consumer and commercial customers around the world. Whether you're a wine enthusiast seeking a dual-zone wine fridge, a homeowner looking for an undercounter beverage outdoor refrigerator, or a business owner in need of an iconic wine cooler, HCK delivers reliable cooling solutions to elevate your lifestyle and enhance your kitchen experience.

Email: info@hcknorthamerica.com
Web: www.hcknorthamerica.com
Tel: 855-478-4203

Models may be subject to modification without prior notice. We reserve the right to make, at anytime, changes deemed necessary to improve products.



HCK

HOW COOL IS THAT?!