







ASSEMBLY INSTRUCTION

020-636 Anna Side Chair

HARDWARE LIST

A		Long Bolt	Ø5/16"*3-1/8"	4 PCS
B		Short Bolt	Ø5/16"*1-3/4"	1 PCS
C		Nut	Ø5/16"	4 PCS
D		Lock Washer	Ø5/16"	9 PCS
E		Flat Washer	Ø5/16"*19D	9 PCS
F		Spanner Wrench	12MM	1 PC
G		Allen key	100*50*4mm	1 PC

PART LIST

1	Chair Back	1 PC
2	Seat Frame	1 PC
3	Front Leg	2 PCS

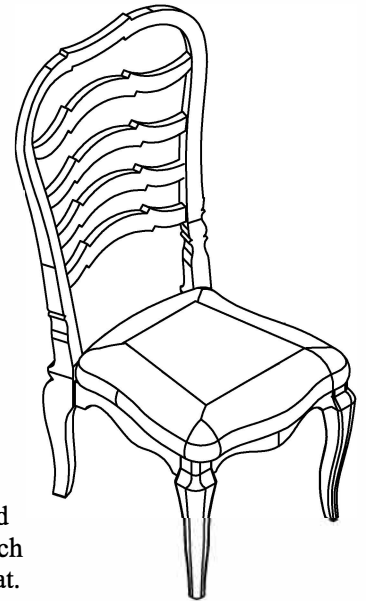

IMPORTANT NOTES

- Place all wooden parts on clean and smooth surface such as rug or carpet to prevent the parts from being scratched.
- Check to be sure that you have all parts and hardware.
- Remove all wrapping materials, including staples and packing straps before you start to assemble.
- Do not tighten all screws and bolts until completely assembled.
- Keep all hardware out of the reach of children

STEP 4. To ensure chair is stable, tighten bolts (A,B) and nuts (C) using the allen key (H), Spanner Wrench (F) while applying downward pressure to the seat.

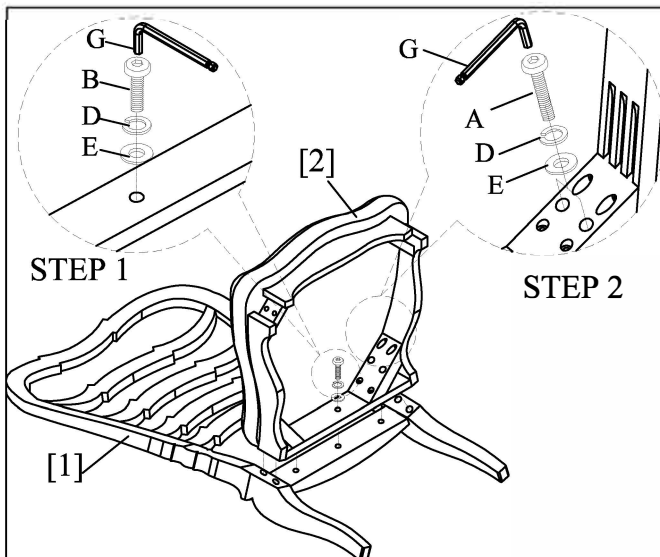

STEP 1. Place chair back (1) on a clean & padded surface then attach seat frame (2) to the chair back using bolt (B), lock washer (D), flat washer (E), and tighten with allen key (G). Important: Do not over-tighten.

STEP 2. Attach back assembly to the seat frame (2) using bolt (A), lock washer (D), flat washer (E), and tighten with allen key (G). Important: Do not over-tighten.

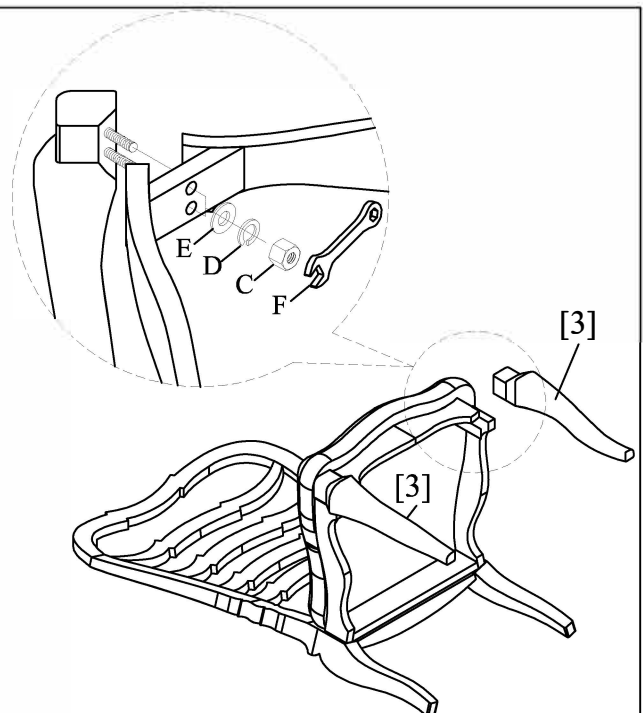

STEP 3. Attach the front leg (3) to the seat frame (2) using nut (C), lock washer (D), flat washer (E), and tighten with Spanner Wrench (F). Important: Do not over-tighten.

MADE IN VIETNAM