

## Table of Contents

---

Dimensions.....	3
Weight Capacity.....	4
Package Contents.....	5
Hardware Contents.....	6
Assembly Instruction.....	7-9

# Dimensions

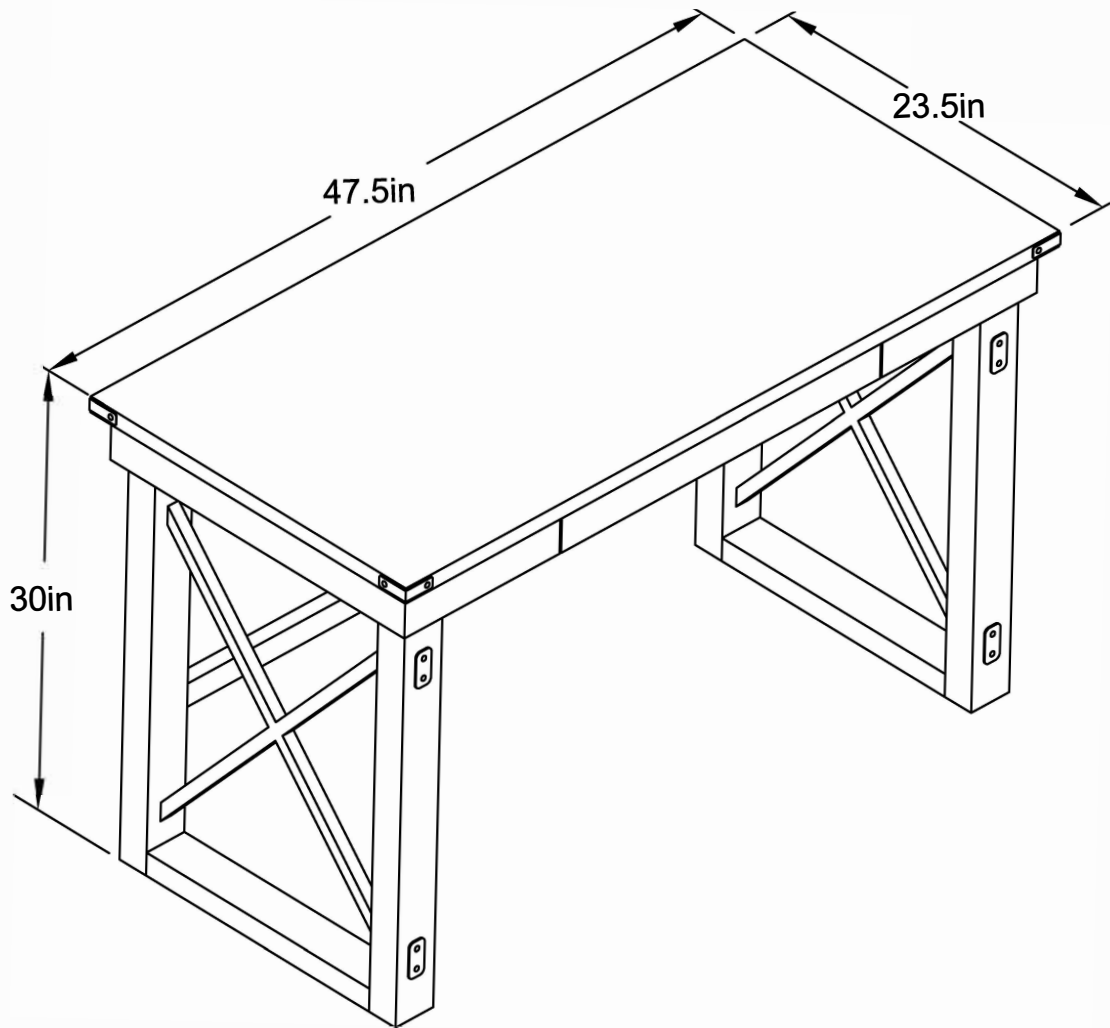

## Weight Capacity

---

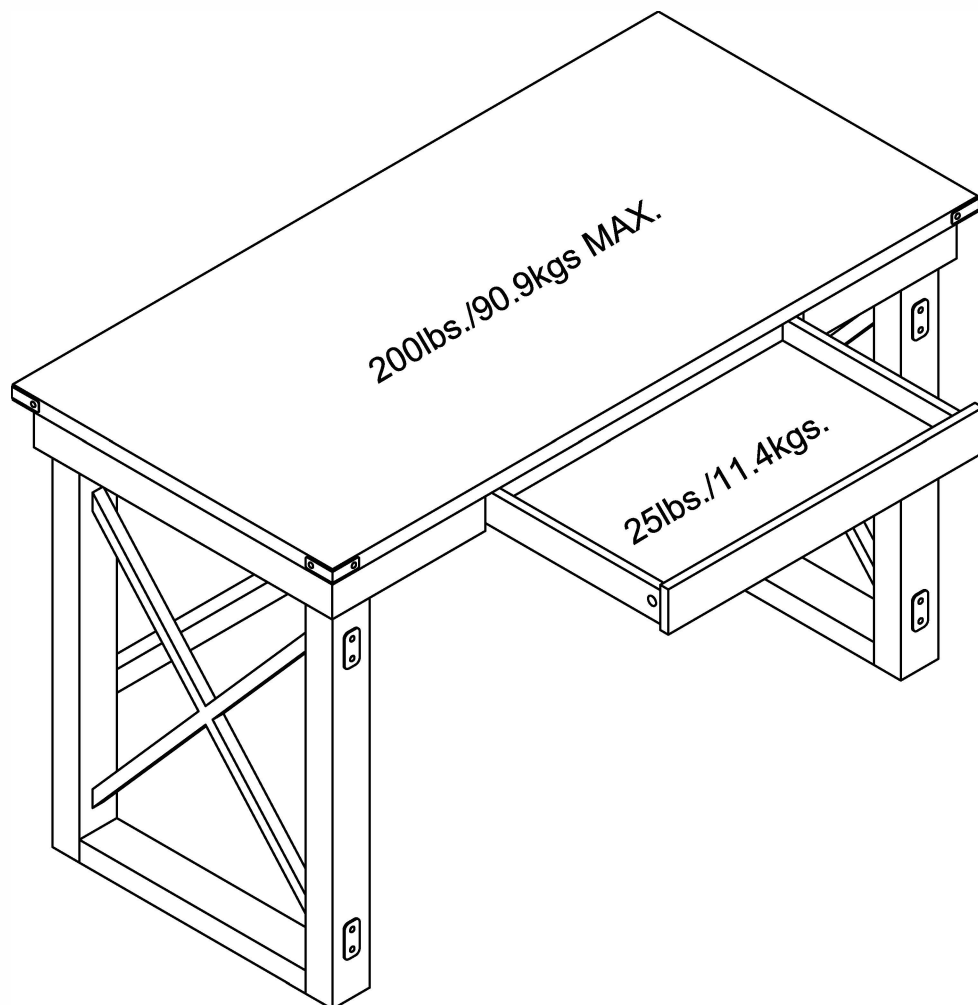

### WARNING:

For use with most flat-panel televisions weighing 43.2kgs/95lbs or less.  
Usage with televisions or loads heavier than the maximum weights specified may result in instability causing tip over resulting in death or serious injury.

# Package contents

---

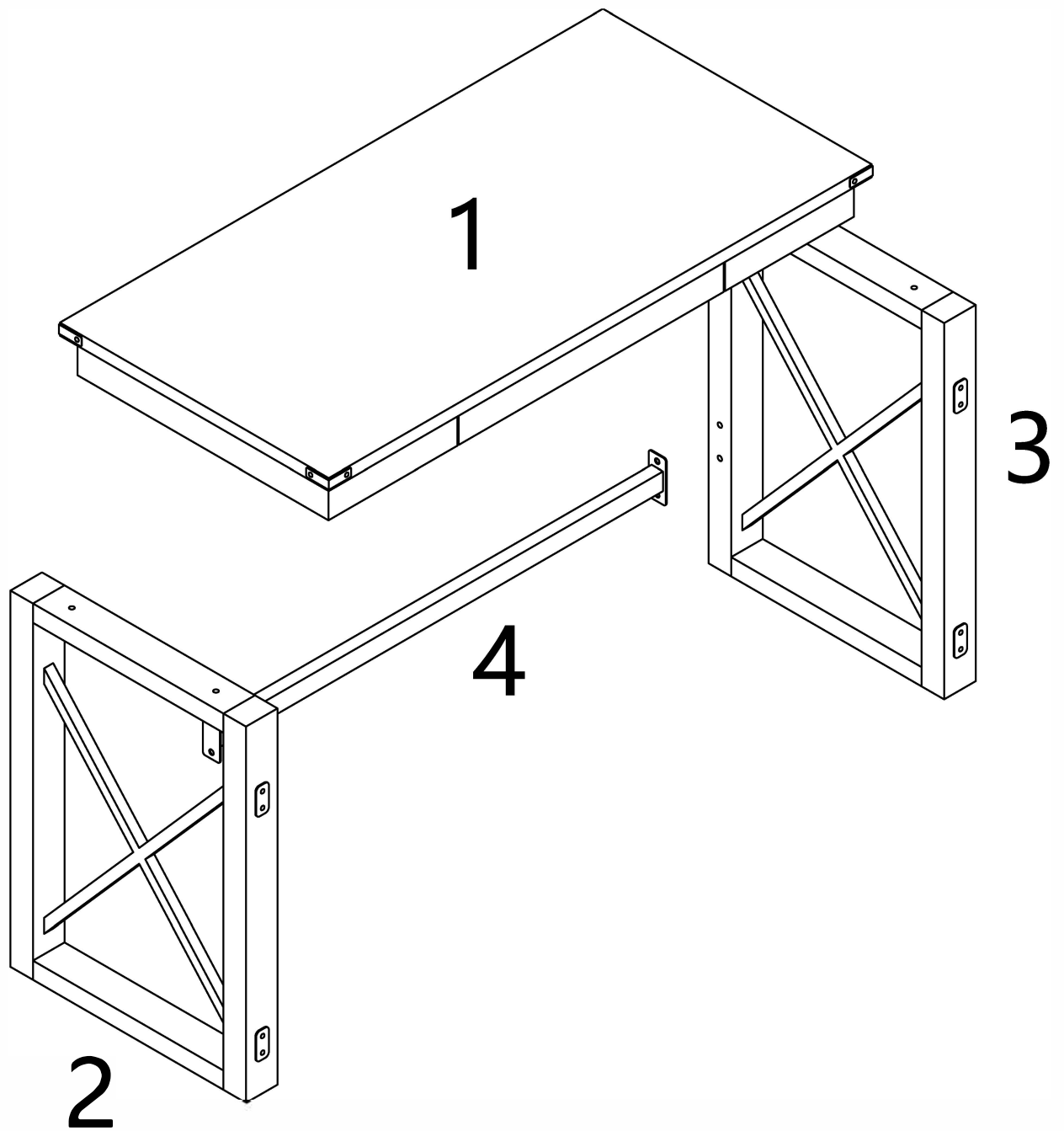

# Hardware contents

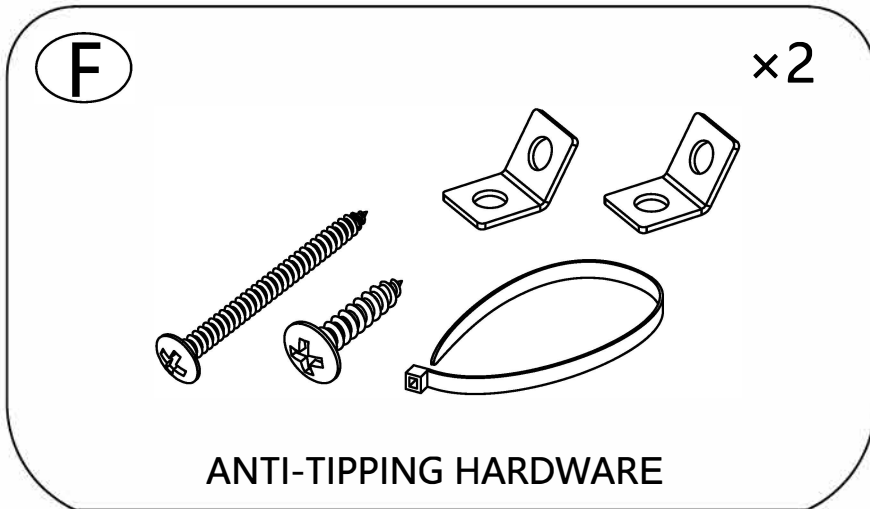
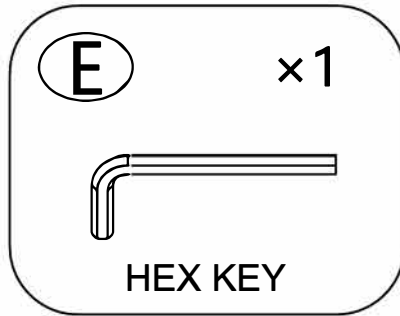
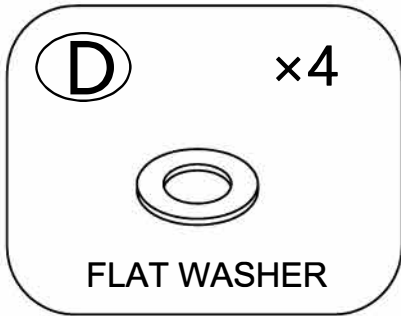
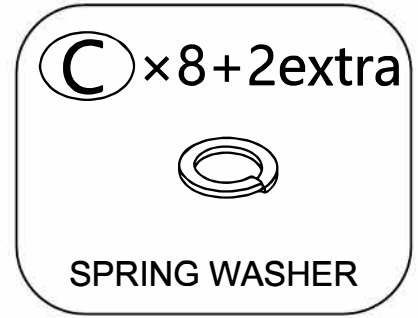
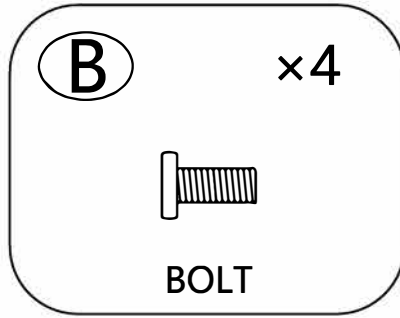
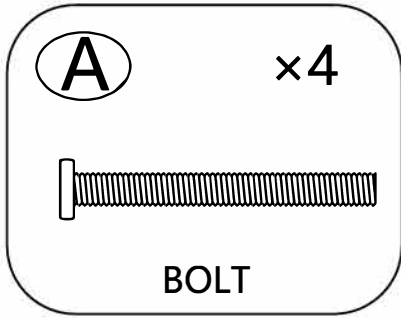

# Assembly Instructions

1

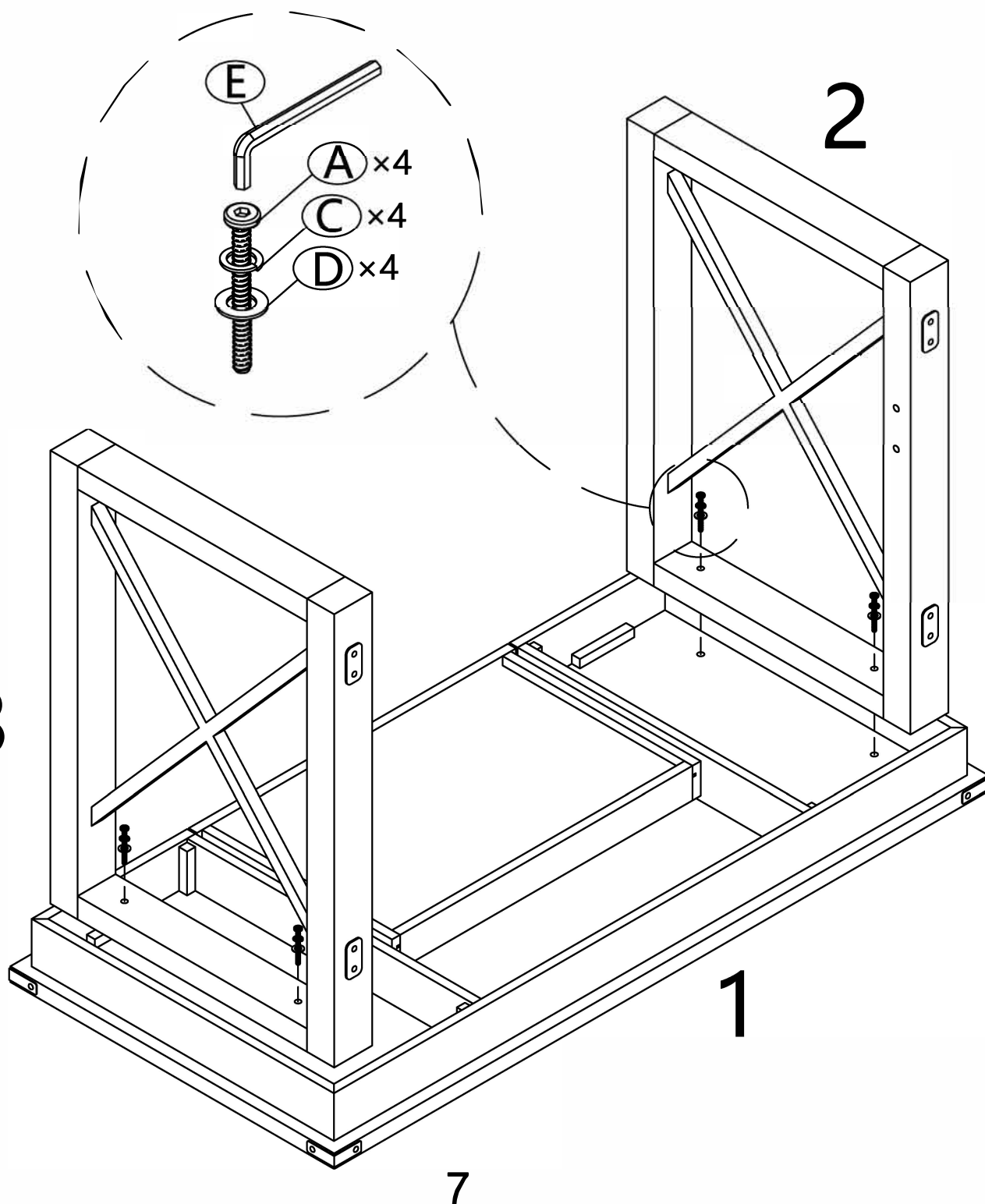

2

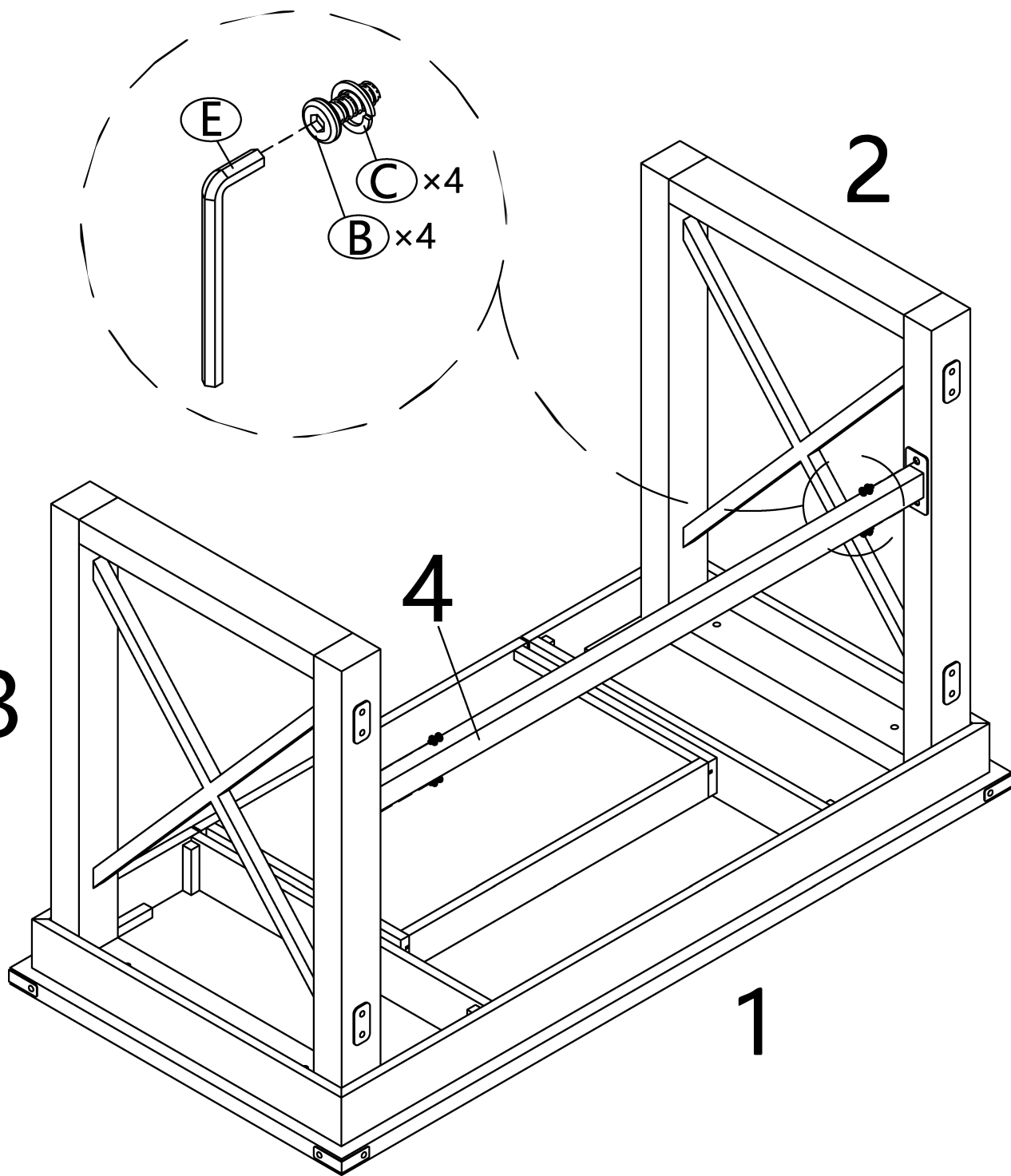

3

