

## **Blast Cabinet Dust Reclaimer Kit**

We continue to be committed to provide you tools with competitive price.

"Save Half", "Half Price" or any other similar expressions used by us only represents an estimate of savings you might benefit from buying certain tools with us compared to the major top brands and does not necessarily mean to cover all categories of tools offered by us. You are kindly reminded to verify carefully when you are placing an order with us if you are actually saving half in comparison with the top major brands.

## Blast Cabinet Dust Reclaimer Kit



### NEED HELP? CONTACT US!

Have product questions? Need technical support? Please feel free to contact us

This is the original instruction, please read all manual instructions carefully before operating. We reserves a clear interpretation of our user manual. The appearance of the product shall be subject to the product you received. Please forgive us that we won't inform you again if there are any technology or software updates on our product.



Warning-To reduce the risk of injury, user must read instructions manual carefully.

## INSTRUCTIONS

This Blast Cabinet dust Reclaimer Kit is for industrial sandblaster cabinet only. It is small, easy use and efficient. It can be greatly helpful to keep the working sandblaster cabinet clean.

### Specifications:

Electrical Rating	120V/60Hz	220-240V 50Hz
Motor Rate	1300W	1300W
Product Compatibility	For use with Industrial Blast Cabinet	
Capacity	Approximately 2 Gallon	

Read all safety warnings and instructions. Failure to follow the warnings and instructions may result in electric shock, fire and/or serious injury. Save all warnings and instructions for future reference.

## DUST RECLAIMER SAFETY WARNINGS

1. Do not use with any openings blocked. Keep openings clear of anything that may limit air flow or hinder motor operation.
2. Do not use the Reclaimer without its filter in place. Before each use, make sure the filter is not clogged.
3. This product is designed only to pick up dry debris. Do not use the Dust Reclaimer to pick up water (or any other liquid) from the floor or containers such as sinks, tubs, barrels, etc.
4. Do not use for abrasives containing crystalline silica. Silica containing abrasives

have been linked to severe respiratory disease such as silicosis. Use proper abrasives such as aluminum oxide, glass bead, or walnut shell.

5. DO NOT OPERATE WITH ANY GUARD DISABLED, DAMAGED, OR REMOVED.

6. The use of accessories or attachments not recommended by the manufacturer may result in a risk of injury to persons.

7. When servicing use only identical replacement parts.

8. Avoid unintentional starting. Prepare to begin work before turning on the tool.

## HOW TO INSTALL THE DUST RECLAIMER TO A BLAST CABINET

1. This dust reclaimer Kit is already assembled in the factory. But please check carefully about the situation of parts connection and screws.

2. Assemble the rubber sealing ring in the proper hole of sandblaster cabinet. Fix the dust reclaimer Kit well with matched screws.

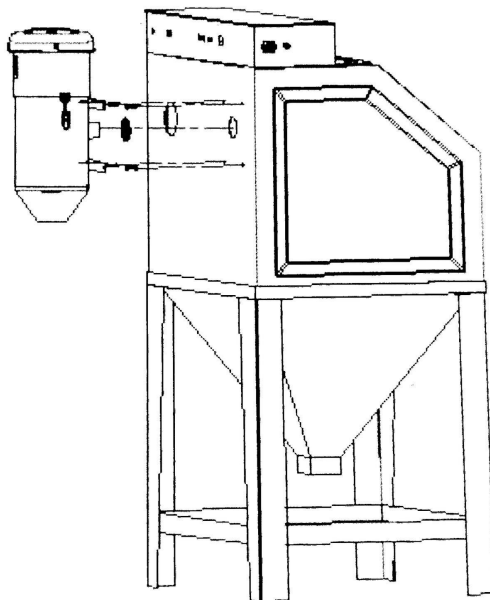

## OPERATION INSTRUCTION

1. Connect with power. Press the switch the kit will start to work.

**Note:**The dust will be heaped up much in the fabric filter after some time usage that will cause the low efficiency of cleaning. Please pull the dust -off rod to flick dust from filter. If this operation does not work, the dust container? may be full, please empty it.

2. Open the lock in the bottom to empty the dust. If it is needed to clean fully, open the two locks in the middle to separate the dust container.

3. There is one metal spare plate for extra usage. This dust reclaimer Kit can be used in other sandblaster cabinets too. Making the holes with spare plate in the machine, assemble the rubber sealing ring and kit into the air outlet. Fix the kit and spare plate with screws. If combine with original cabinet, this spare plate is no necessary.

4. To prevent accidents, turn off the tool and disconnect its power supply after use.

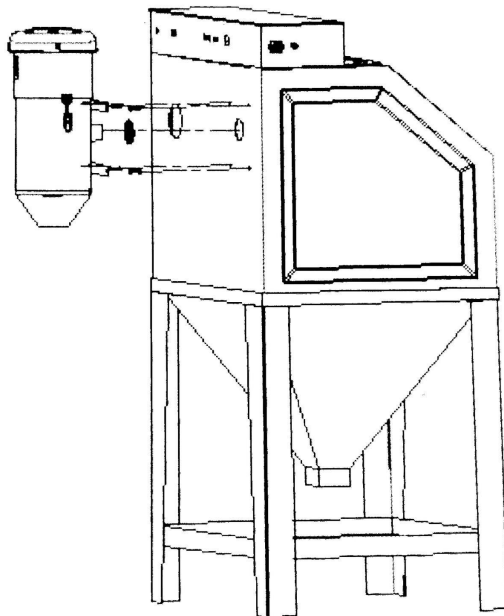

## TROUBLESHOOTING

Problem	Possible Solutions
Dust reclaimer does not turn on.	<ol style="list-style-type: none"><li>1. Make sure the Power Switch on is in its "ON" position.</li><li>2. Make sure the Power Cord Plug of the dust reclaimer is properly connected to a working volt, grounded, electrical outlet.</li><li>3. Have a qualified service technician check out the Dust reclaimer and Blast Cabinet.</li></ol>
Poor visibility within the Blast Cabinet.	<ol style="list-style-type: none"><li>1. Check to make sure dust reclaimer is on.</li><li>2. Dust reclaimer is filled. Empty and clean out Dust reclaimer.</li><li>3. Filter in dust reclaimer needs to be cleaned or replaced.</li><li>4. Have a qualified service technician check out the dust reclaimer and Blast Cabinet.</li></ol>

### PLEASE READ THE FOLLOWING CAREFULLY

The manufacturer and/or distributor has provided the parts list and assembly diagram in this manual as reference only. Neither the manufacturer or distributor makes any representation or warranty of any kind to the buyer that he or she is qualified to make any repairs to the product, or that he or she is qualified to replace any parts of the product. In fact, the manufacturer and/or distributor expressly states that all repairs and parts replacements should be undertaken by certified and licensed technicians, rather than by the buyer. The buyer assumes all risk and liability arising out of his or her repairs to the original product or replace parts thereto, or arising out of his or her installation of replacement parts thereto.

## PARTS LIST

NO.	Parts	QTY	NO.	Parts	QTY
1	Srcews M6*12	4	17	butterfly nut M6	1
2	Top cover	1	18	Srcews M4*10	8
3	Srcews M5*10	4	19	Lock	3
4	Motor setting plate	2	20	Nuts M4	6
5	Nuts M5	4	21	Dust container	1
6	Motor	1	22	Gum cotton	1
7	Motor Barrel	1	23	Bakelite handle	1
8	Power cord	1	24	Spring	1
9	Wire sleeve	1	25	Pull rod	1
10	Nuts M6	7	26	Guide plate	1
11	Screws arbor M6*310	1	27	Rubber seal ring	1
12	Thermal protector	1	28	Connection line	1
13	Switch	1	29	Srcews M6*12	4
14	Filter stand	1	30	Nuts M6	
15	Gum cotton	1	31	Steel washer M6	4
16	Washer Ø6	4			

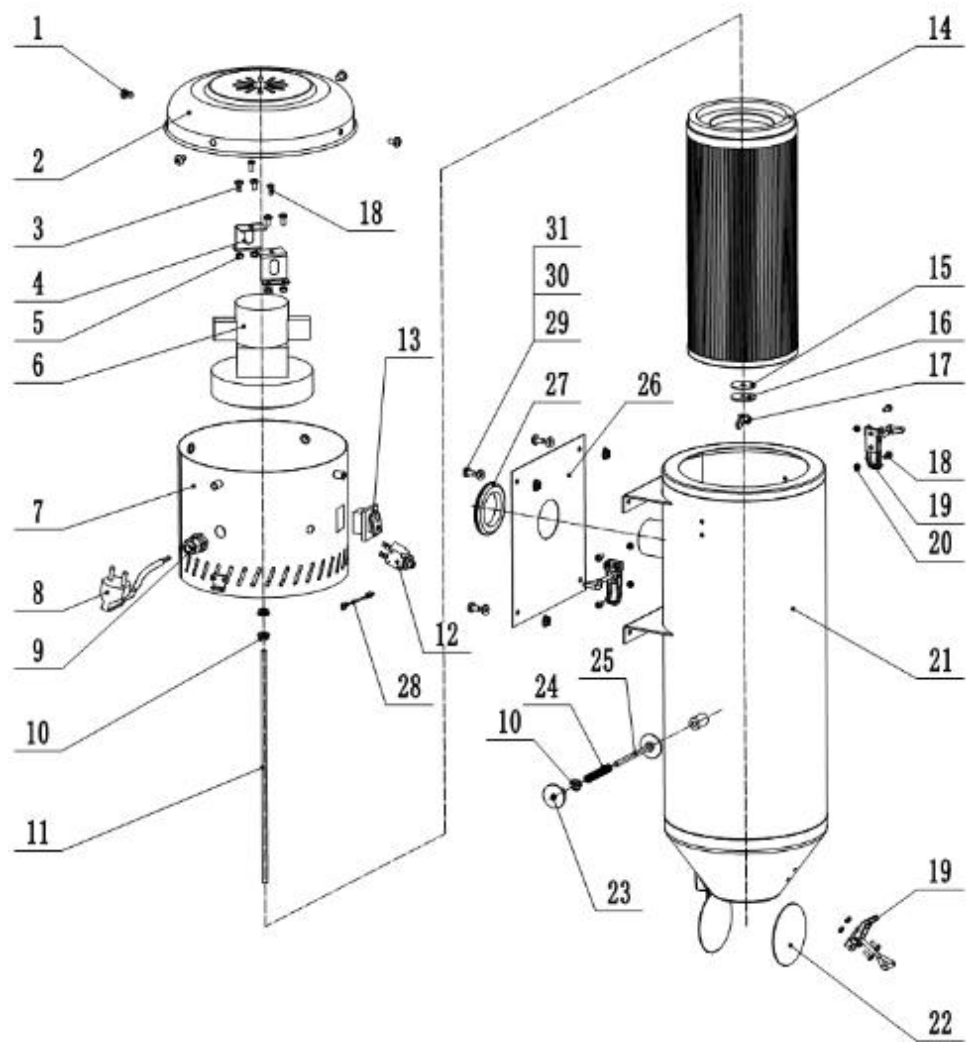

# FCC INFORMATION

**CAUTION:** Changes or modifications not expressly approved by the party responsible for compliance could void the user's authority to operate the equipment!

This device complies with Part 15 of the FCC Rules. Operation is subject to the following two conditions:

- 1) This product may cause harmful interference.
- 2) This product must accept any interference received, including interference that may cause undesired operation.

**WARNING:** Changes or modifications to this product not expressly approved by the party responsible for compliance could void the user's authority to operate the product.

**Note:** This product has been tested and found to comply with the limits for a Class B digital device pursuant to Part 15 of the FCC Rules, These limits are designed to provide reasonable protection against harmful interference in a residential installation.

This product generates, uses and can radiate radio frequency energy, and if not installed and used in accordance with the instructions, may cause harmful interference to radio communications. However, there is no guarantee that interference will not occur in a particular installation. If this product does cause harmful interference to radio or television reception, which can be determined by turning the product off and on, the user is encouraged to try to correct the interference by one or more of the following measures.

- Reorient or relocate the receiving antenna.
- Increase the distance between the product and receiver.
- Connect the product to an outlet on a circuit different from that to which the receiver is connected.
- Consult the dealer or an experienced radio/TV technician for assistance.

## CORRECT DISPOSAL



This product is subject to the provision of Directive 2012/19/EU.

The symbol showing a wheelie bin crossed through indicates that the product requires separate refuse collection. This applies to the product and all accessories marked with this symbol. Products marked as such may not be

discarded with normal domestic waste, but must be taken to a collection point for recycling electrical and electronic devices.