

NOTICE BEFORE ASSEMBLY

Please choose the CHAISE to be on
the LEFT or RIGHT hand side

Assembly Instruction I :CHAISE ON THE LEFT

ITEM NO.:F7615,F6423,F6424

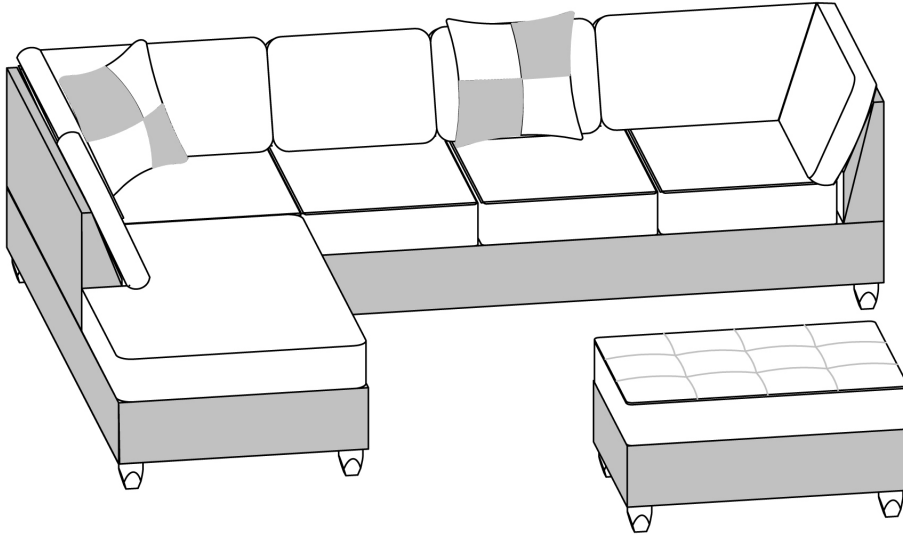

PARTS LIST

BOX-1	BOX-2	BOX-3
<p>*Cushions, pillow and legs included</p>	<p>*Cushions, pillow and legs included</p>	<p>*Cushions and legs included</p>
1. X12	2. X12	3. X12
4. X12	5. X2	6. X8

BEFORE ASSEMBLY

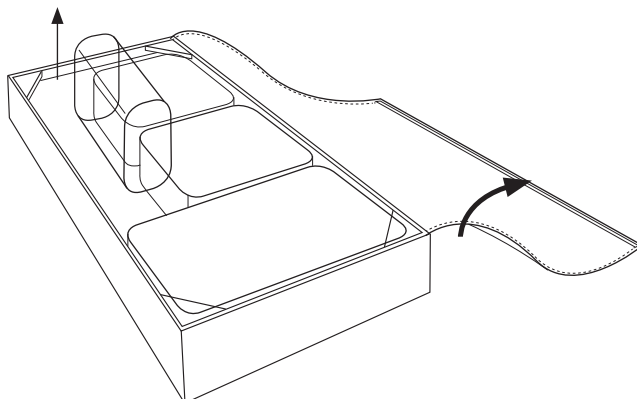

Open up the Velcro of Non-Woven Fabric cover on the bottom of the seat frame to remove seat cushions, back cushions and pillow

*****PLEASE REMOVE ALL PARTS FROM SEAT FRAMES AND SEAT BACKS BEFORE ASSEMBLY*****

CHAISE ON THE LEFT

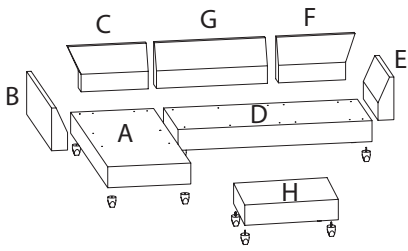

CHAISE - BOX 1

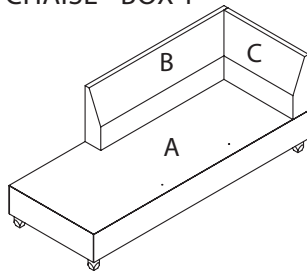

SOFA - BOX 2

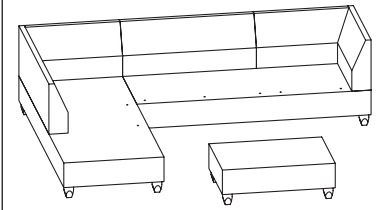
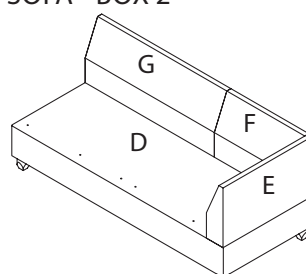

CHAISE ASSEMBLY INSTRUCTION-BOX 1

STEP 1- INSERT THREADED ROD INTO SEAT BACKS

* Shorter end of the threaded screw going into the back panel.*

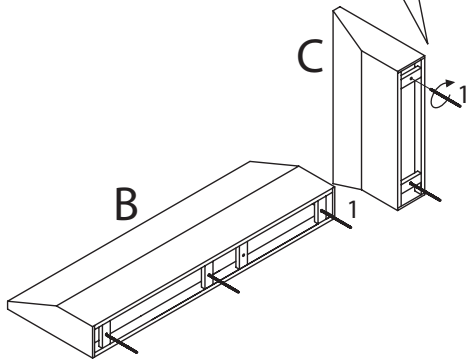
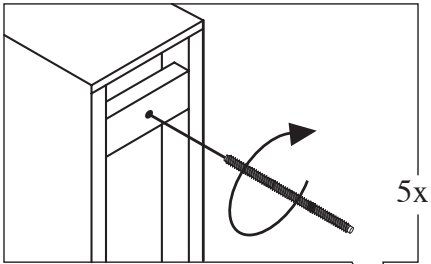

STEP 2- MOUNTED SEAT BACKS INTO THE SEAT FRAME

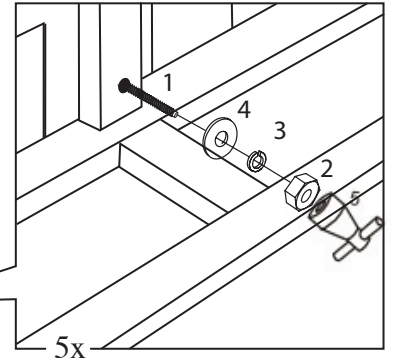
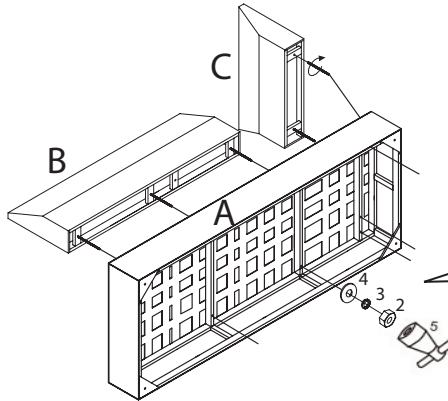

STEP 3- PUT BACK THE FABRIC COVER AND INSERT LEGS

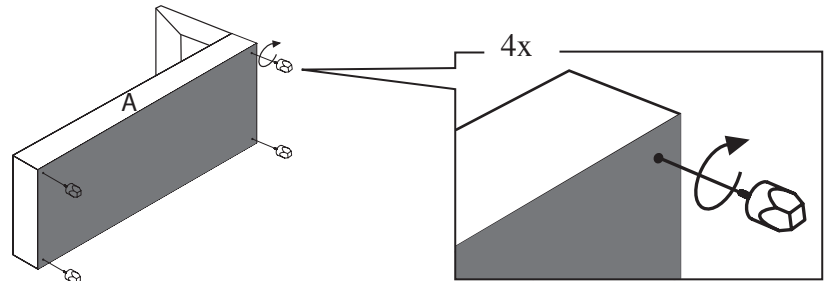

SOFA ASSEMBLY INSTRUCTION-BOX 2

STEP 1- INSERT THREADED ROD INTO SEAT BACKS

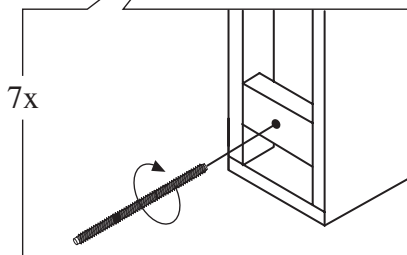
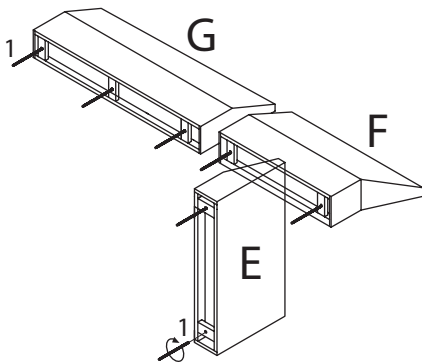

* Shorter end of the threaded screw going into the back panel.*

STEP 2- MOUNTED SEAT BACKS INTO THE SEAT FRAME

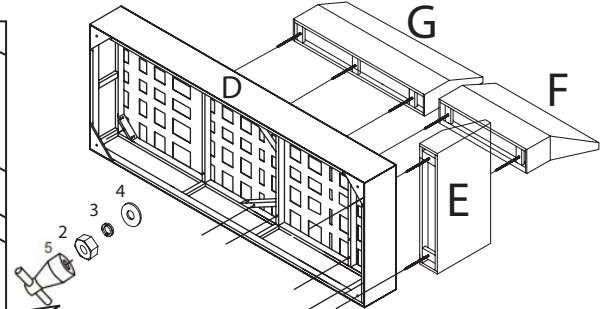
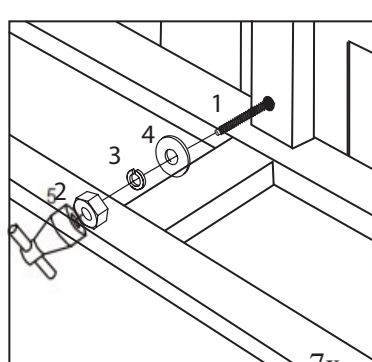

STEP 3- PUT BACK THE FABRIC COVER AND INSERT LEGS

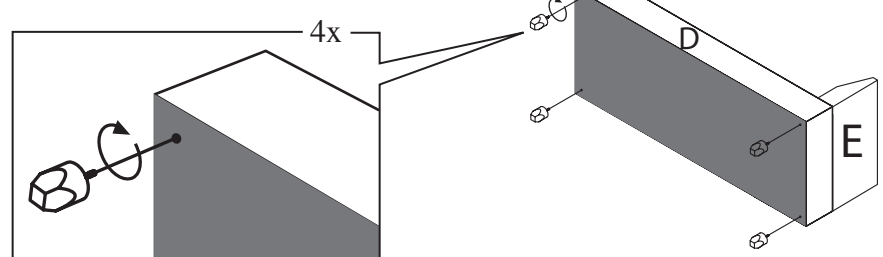

NOTICE BEFORE ASSEMBLY

Please choose the CHAISE to be on _____
 the LEFT or RIGHT hand side _____

Assembly Instruction II:CHAISE ON THE RIGHT

ITEM NO.:F7615,F6423,F6424

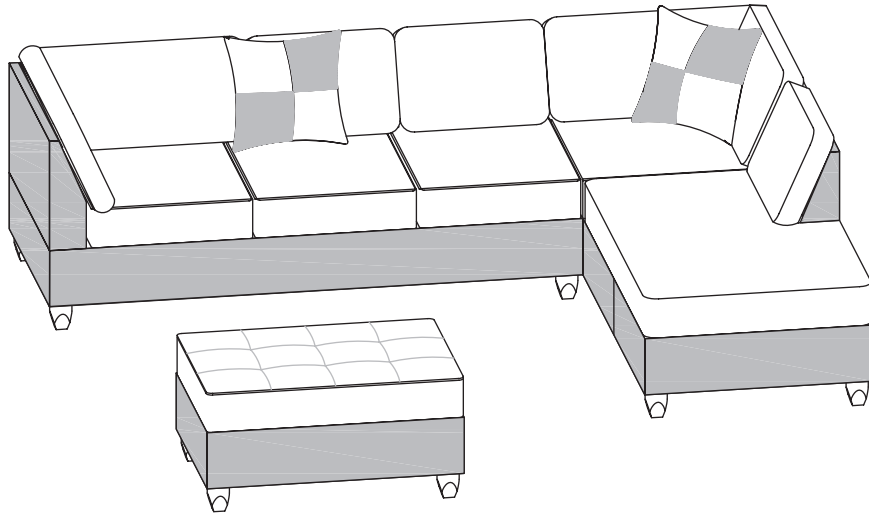

PARTS LIST

BOX-1	BOX-2	BOX-3
<p>*Cushions, pillow and legs included</p>	<p>*Cushions, pillow and legs included</p>	<p>*Cushions and legs included</p>
1. x12	2. x12	3. x12
4. x12	5. x2	6. x8

BEFORE ASSEMBLY

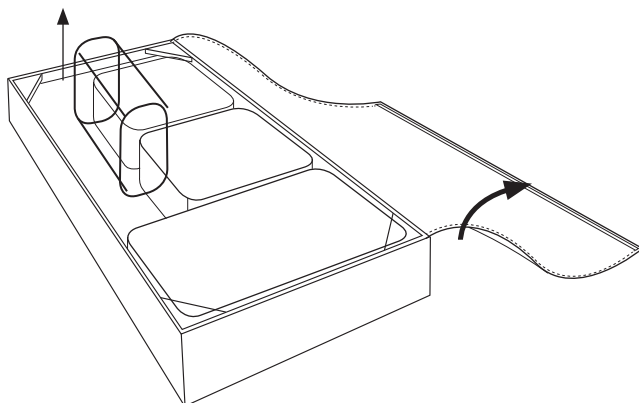

Open up the Velcro of Non-Woven Fabric cover on the bottom of the seat frame to remove seat cushions, back cushions and pillow

*****PLEASE REMOVE ALL PARTS FROM SEAT FRAMES AND SEAT BACKS BEFORE ASSEMBLY*****

CHAISE ON THE RIGHT

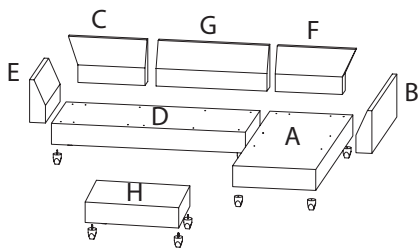

CHAISE - BOX 1

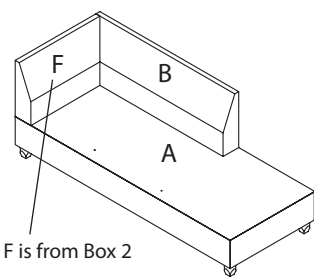

SOFA - BOX 2

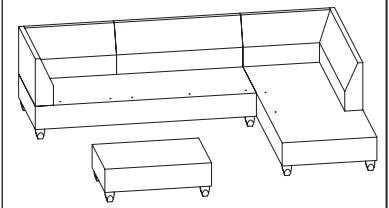
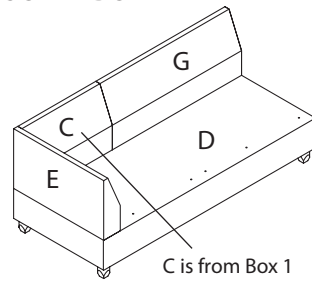

CHAISE ASSEMBLY INSTRUCTION-BOX 1

STEP 1- INSERT THREADED ROD INTO SEAT BACKS

* Shorter end of the threaded screw going into the back panel.*

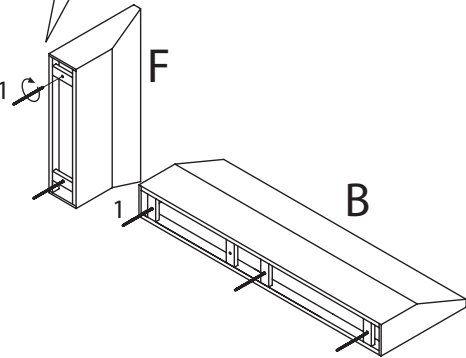
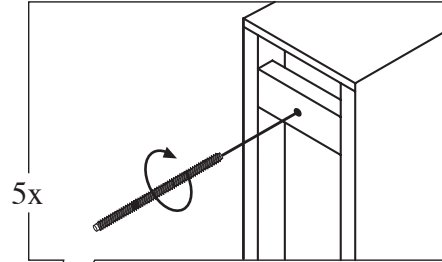

STEP 2- MOUNTED SEAT BACKS INTO THE SEAT FRAME

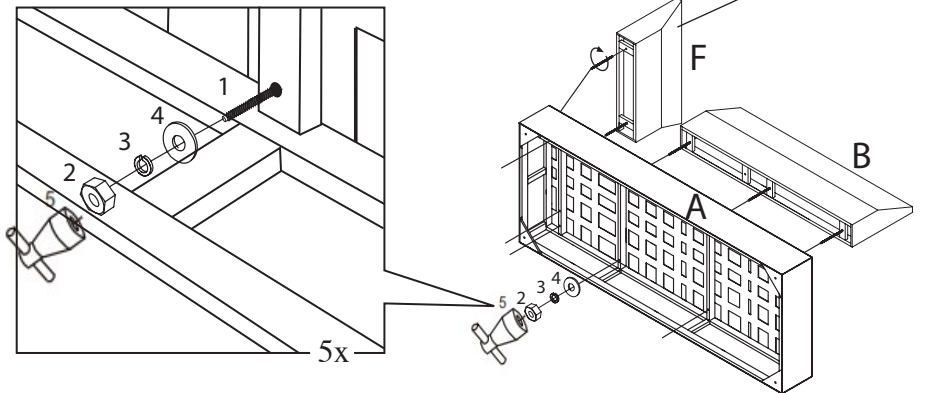

STEP 3- PUT BACK THE FABRIC COVER AND INSERT LEGS

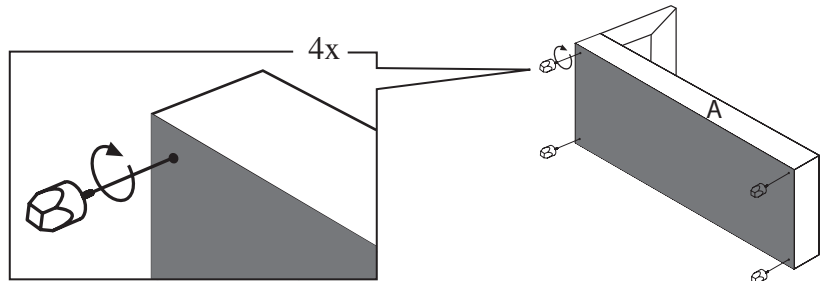

SOFA ASSEMBLY INSTRUCTION-BOX 2

STEP 1- INSERT THREADED ROD INTO SEAT BACKS

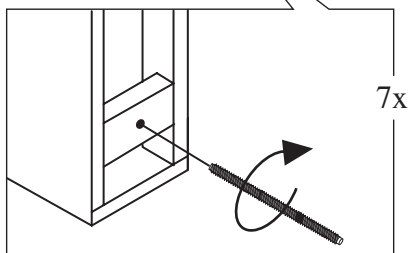
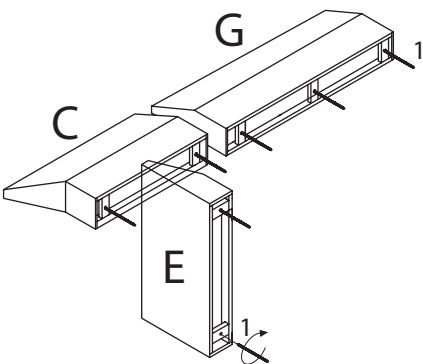

* Shorter end of the threaded screw going into the back panel.*

STEP 2- MOUNTED SEAT BACKS INTO THE SEAT FRAME

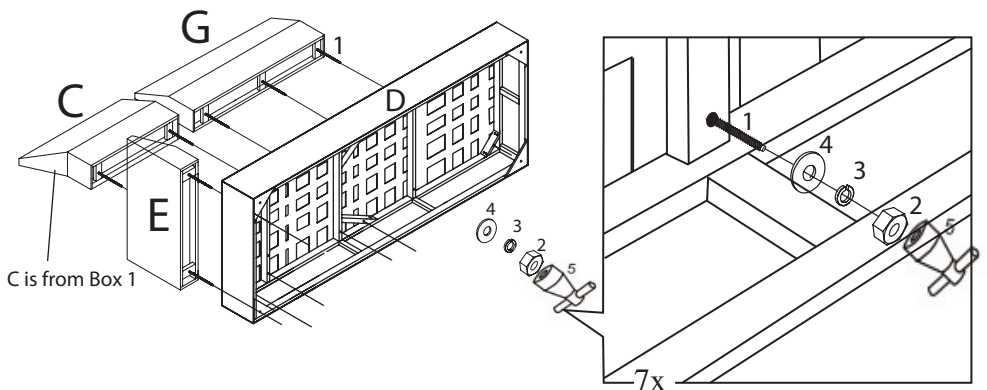

STEP 3- PUT BACK THE FABRIC COVER AND INSERT LEGS

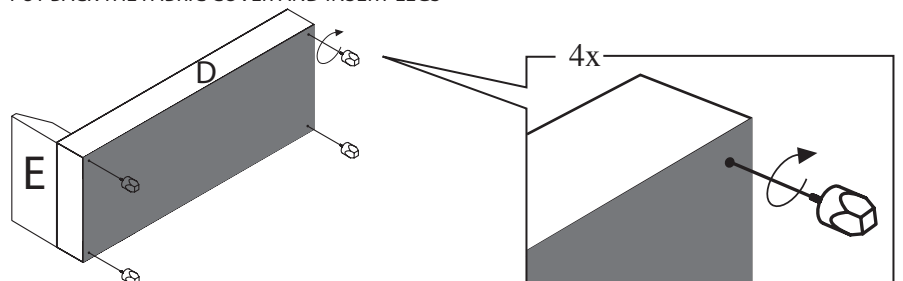

Assembly Instructions

ITEM NO.: F7615,F6423,F6424

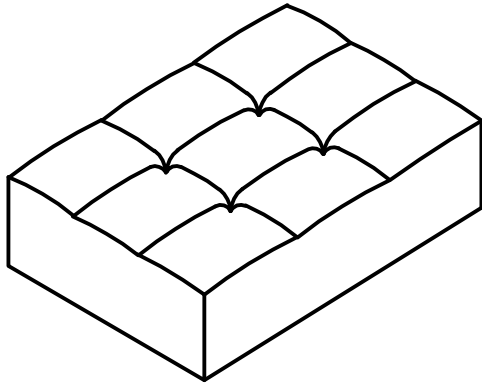

1

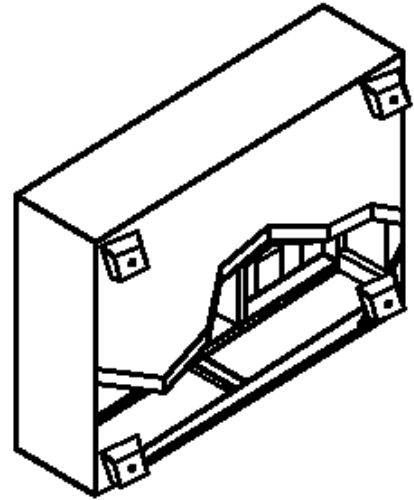

2

3

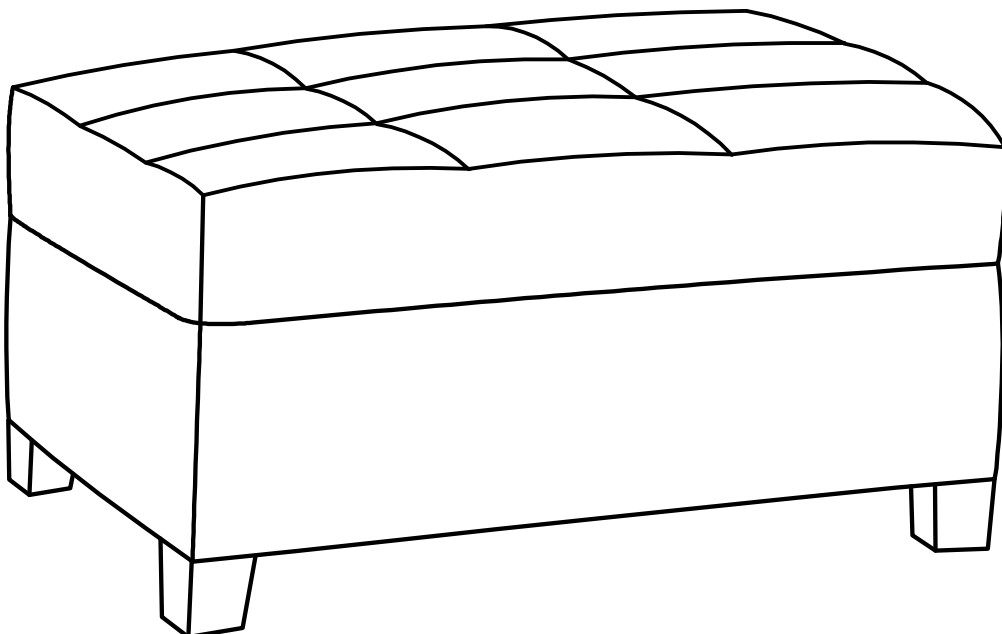
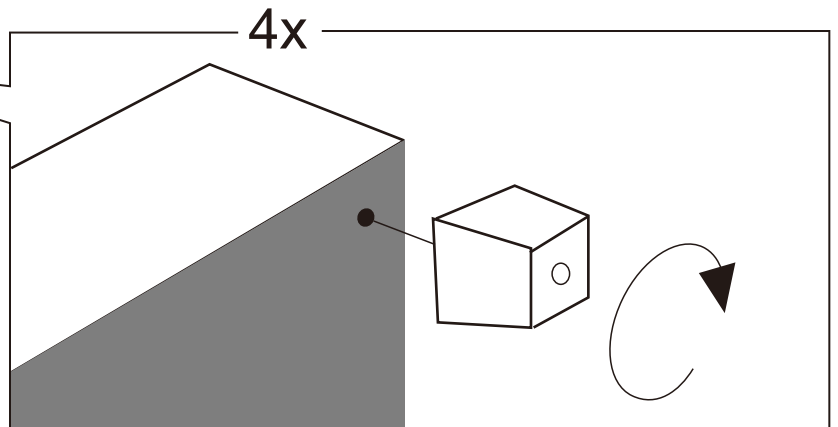
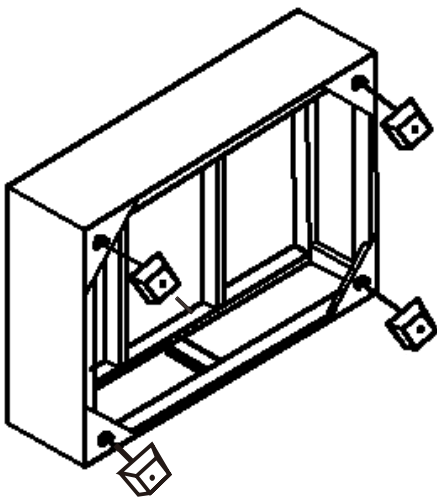

4

INSERT THE "n" SHAPE HANGER INTO THE SEAT FRAME TO ATTACH THE SECTIONAL TOGETHER.

