

# ASSEMBLY INSTRUCTIONS

## 24" NAILHEAD STOOL

ASSEMBLY  
REQUIREMENTS

2-PERSON  
ASSEMBLY

45 MINUTES  
ASSEMBLY TIME

TOOLS  
REQUIRED

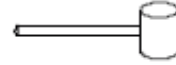

MALLET

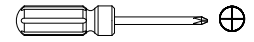

PHILLIPS SCREWDRIVER

### Thank you for purchasing our product!

Please refer and use this assembly instruction to assemble the product. Contact our customer service department in case there are any missing or damage parts or hardware. Replace parts are normally shipped within 2 or 3 days

Within 30 days from delivery date

**We appreciate your business!**

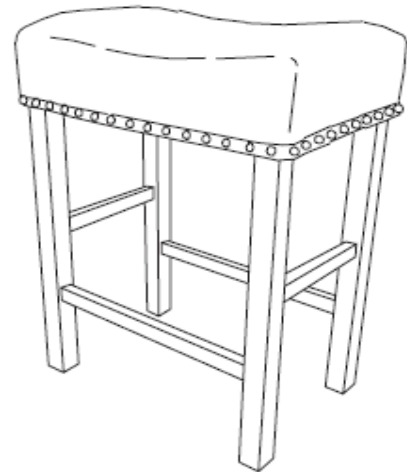

### ASSEMBLY PREPARATION

1. Remove all packing materials, staples and packing straps from the carton.
2. Refer to Parts List and Hardware List. Ensure all the parts, hardware and quantities are correct before assembling the product. Contact customer service for missing part.

### SAFETY PRECAUTION

1. KEEP ALL HARDWARE PARTS OUT OF REACH OF CHILDREN.
2. DISPOSE PLASTIC PACKAGING MATERIAL IMMEDIATELY TO AVOID ANY RISK OF SUFFOCATION TO CHILDREN AND ANIMALS.

### TIPS FOR ASSEMBLY

1. Allow ample room for assembly and in close proximity to where product will be placed.
2. Assemble the product on a surface that does not scratch or damage the exterior gloss and finish of the furniture.
3. Identify all of the parts, hardware and quantities required for each step.
4. During assembly, do not over-tighten any fittings as this may cause damage.
5. DO NOT USE POWER TOOLS TO ASSEMBLE THIS PRODUCT.
6. Always place the product on a flat, level surface.
7. Do not sit or stand on the partially assembled product; only use the product for which it is intended.

### CARE AND MAINTANANCE

- Use a slightly damp cloth to clean the product. Do not use bleach or abrasive cleaning material.
- Check all the fittings periodically and re-tighten as necessary. Do not use the product if any of the parts is damaged or broken.
- Never allow any kind of liquid to remain on your furniture. Absorption can cause wood to warp or delaminate.
- Do not place hot items (e.g. hot drinks) directly onto the wood surface.
- Do not drag and/or pull the furniture.





This product is for indoor and household use only – not for commercial use.

# ASSEMBLY INSTRUCTIONS 24" NAILHEAD STOOL

## PARTS LIST (FOR 2 STOOLS)

NO.	COMPONENT	QTY.
P1	CUSHION SEAT	2
P2	LEGS	8
P3	FRONT STRETCHER (LONG)	4
P4	SIDE STRETCHER (SHORT)	4

## HARDWARE LIST (FOR 2 STOOLS)

NO.	DESCRIPTION	QTY.	EXTRA
H1	JCBC SCREW M6 X 60 	16	1
H2	SPRING WASHER 	16	2
H3	FLAT WASHER 	16	2
H4	SCREW M4 X 38	16	2
H5	LEG STUD 	8	1
H6	ALLEN KEY 	1	

\* Extra Hardware For Spare Use

### STEP 1

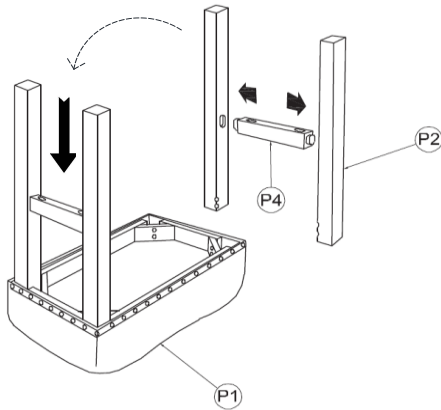

- Place Cushion Seat (P1) bottom-side up on a flat & soft surface.
- Attach 1x Side Stretcher (P4) to a pair of Legs (2).
- Insert the pair of Legs with Side Stretcher into the corners on the left side of (P1) as shown.

### STEP 2

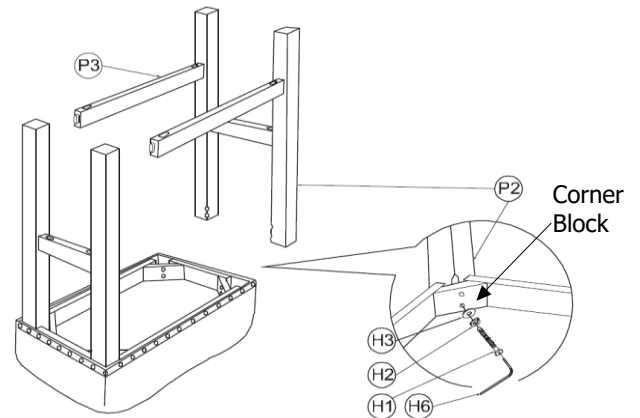

- Attach second Side Stretcher (P4) to another pair of Legs (2) as in Step 1b).
- Attach Front Stretcher (P3) to Legs (2).
- Insert the second pair of Legs with Side Stretcher into the corners on the right side of (P1) as shown.
- Use Screw (H1) fitted with Spring Washer (H3) and Flat Washer (H4) to fasten each Table Leg to Corner Block. Use Allen Key (H7) to drive (H1). Do not tighten (H1) completely until both screws are in place on each leg. Do not over-tighten.

### STEP 3

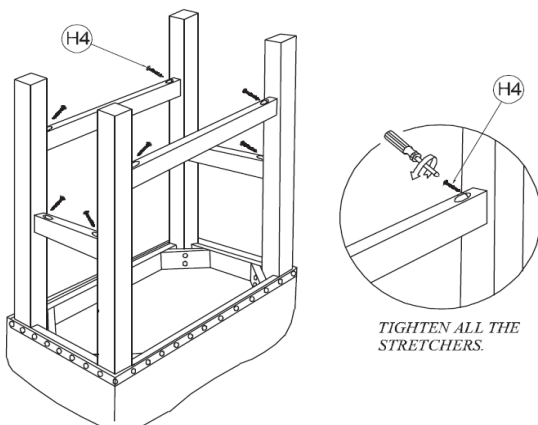

- Use Screw (H4) to fasten Front Stretcher (P3) and Side Stretcher (P4) to each Leg. Use Phillips screwdriver to drive Screw (H4).

### STEP 4

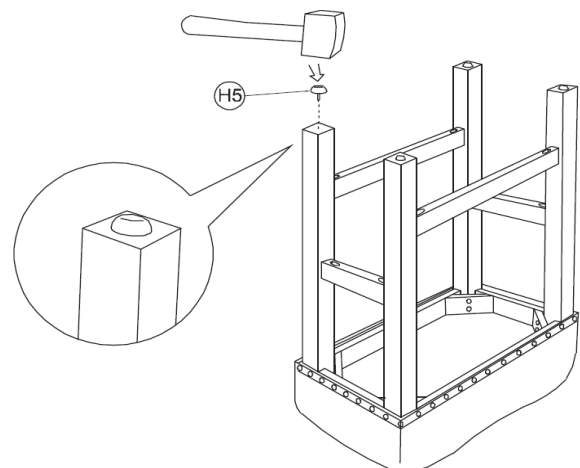

- Use a mallet or hammer to light nail Leg Stud (H5) into the end of each Leg. Next, turn the Stool right-side up.

The assembly of the Stool is complete.