

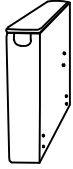

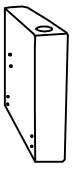

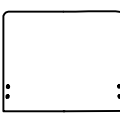

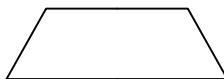







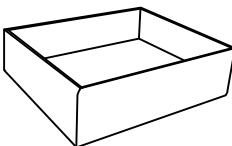





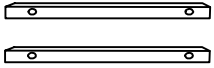
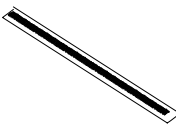

# ASSEMBLY INSTRUCTION

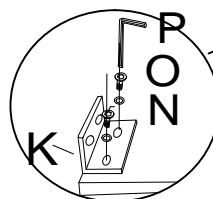
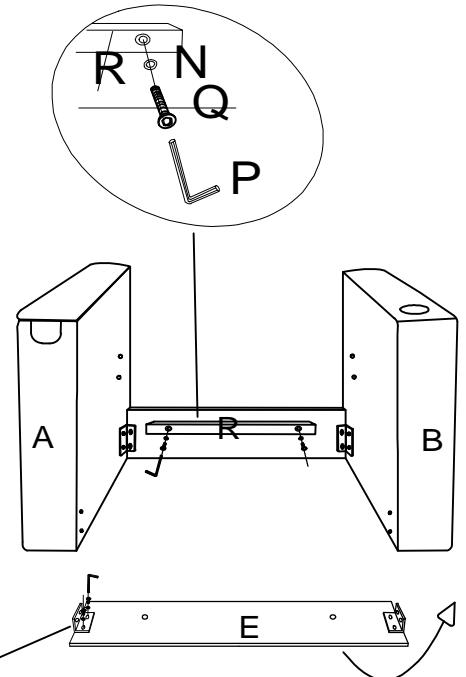
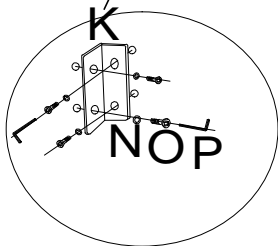
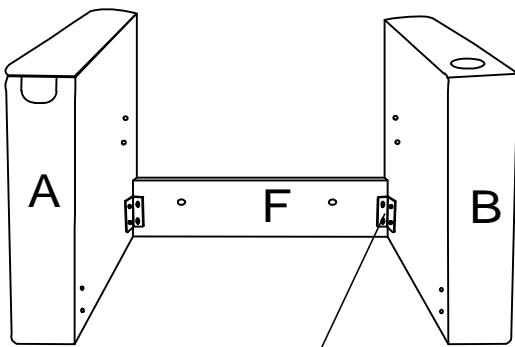
<p>A</p>  <p>Armrest-L X1</p>	<p>B</p>  <p>Armrest-R X1</p>	<p>C</p>  <p>Backrest-sofa X1</p>	<p>D</p>  <p>Seat panel x1</p>	<p>E</p>  <p>Front panel X1</p>
<p>F</p>  <p>Rare panel X1</p>	<p>G</p>  <p>Seat cushion x1</p>	<p>H</p>  <p>Back Cushion x1</p>	<p>I</p>  <p>Ottoman Lid X1</p>	<p>J</p>  <p>Ottoman base X1</p>
<p>K</p>  <p>Corner bracket X6</p>	<p>L</p>  <p>3cm Ottoman lid Leg X4</p>	<p>M</p>  <p>Leg 5cm X8</p>	<p>N</p>  <p>M8*22mm washer X28</p>	<p>O</p>  <p>M8*20mm bolt X24</p>
<p>P</p>  <p>M8 Allen key X1</p>	<p>Q</p>  <p>M8*45mm bolt X4</p>	<p>R</p>  <p>support bar X2</p>	<p>S</p>  <p>Velcro x3</p>	<p>T</p>  <p>PLUG X1</p>

## STEP1:



	K	x4pcs		
	Q	x2pcs		O x12pcs
	N	x12pcs		P x 1pcs

**STEP2:** Reorient the sofa by positioning the backrest to the front and the seat to the rear.

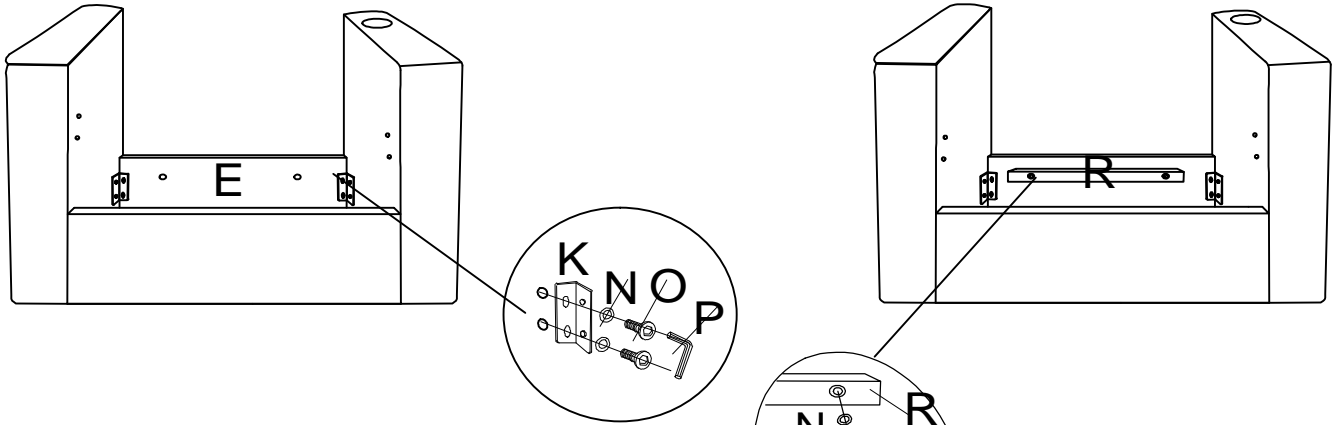

	O	x4pcs		Q	x2pcs
	N	x6pcs		P	x1pcs

**STEP3:**

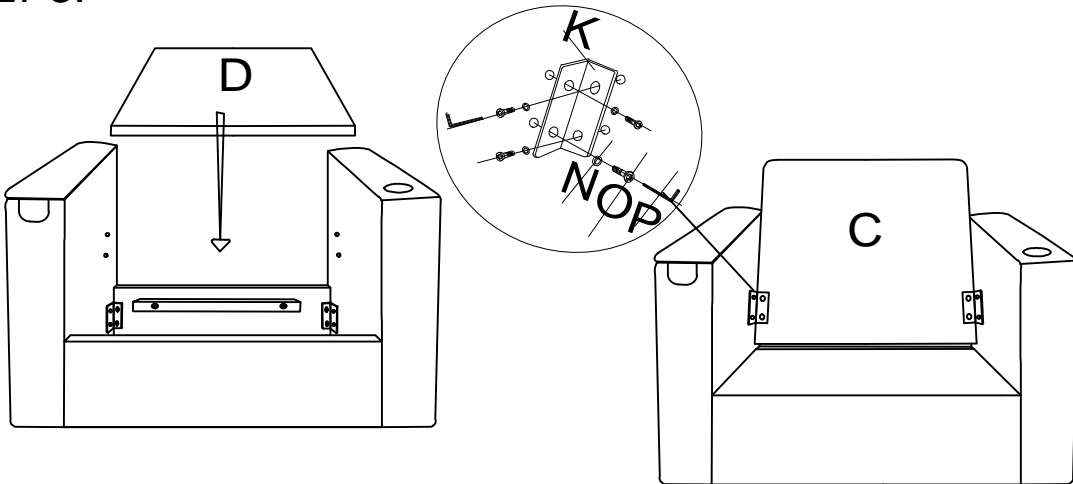

	K	x2pcs
	N	x8pcs
	O	x8pcs
	P	x1pcs

**STEP4:**

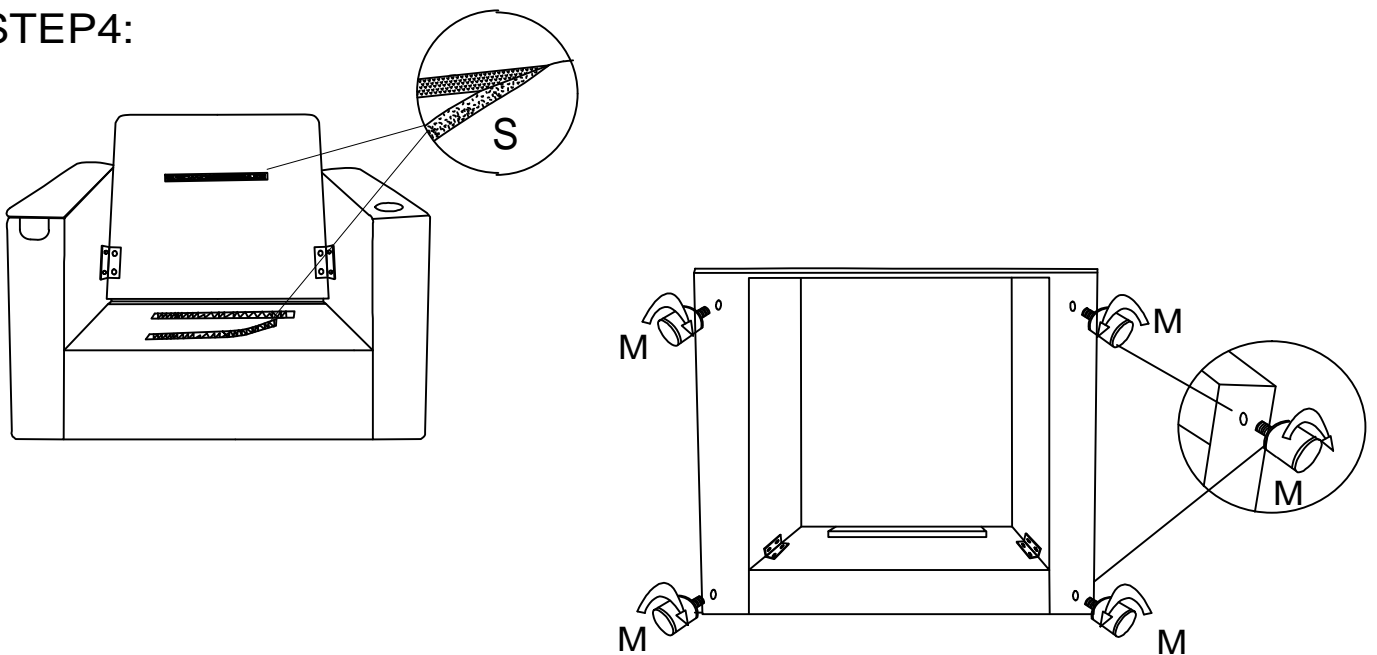

	M	x4pcs
--	---	-------

### STEP5:

You can follow the instructions as below which can make back cushion plumpy more faster .

1. Grab each end of the pillow with both hands.

It's like playing an accordion, pushing the pillow together and pulling it apart, be faster as you can .

If the pillow is not absorbing too much moisture, you can use both fists to hit both sides of the pillow at the same time to loosen the stuffing.

2. Punch the throw pillow.

Pls wait for 48-72 hours before using .

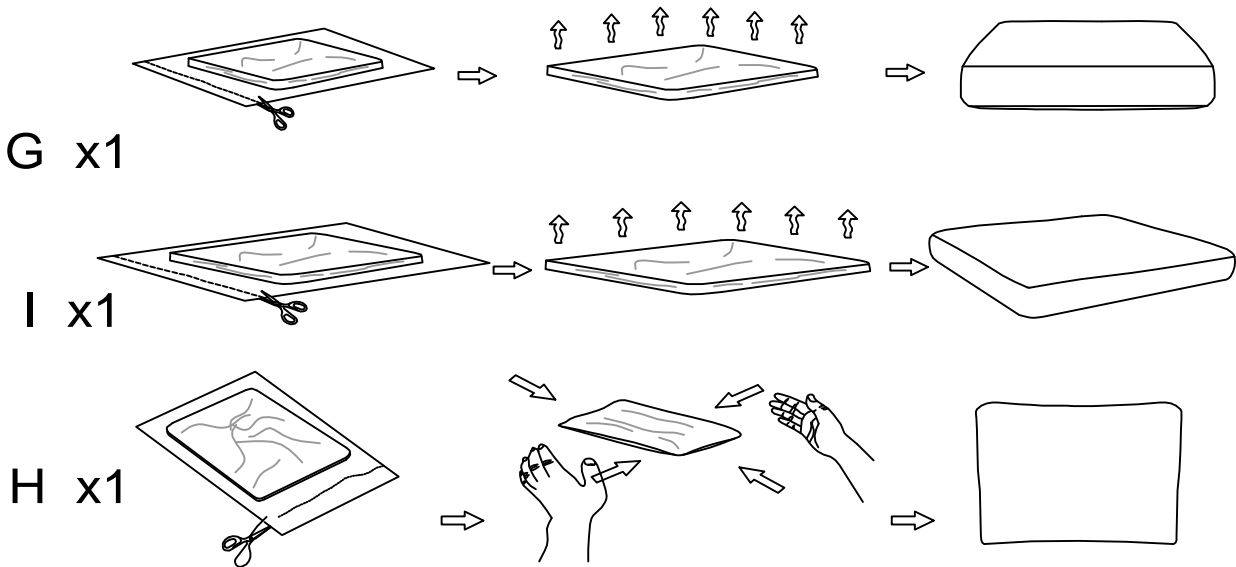

### STEP6:

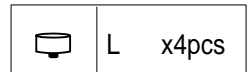
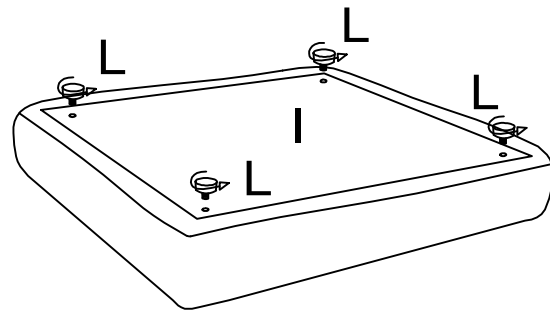
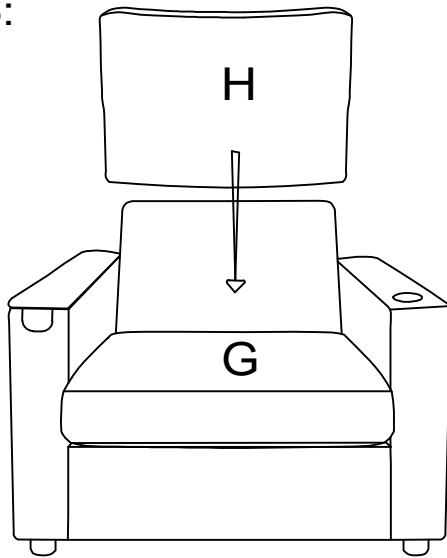

### STEP7:

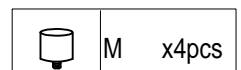
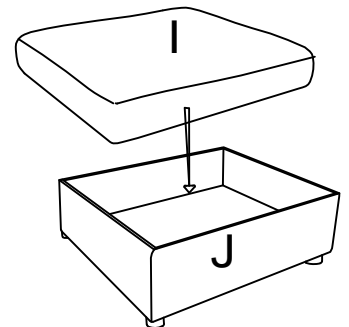
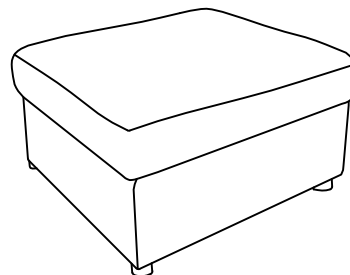
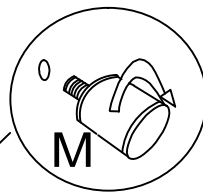
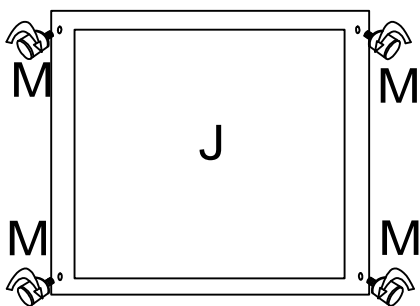

## STEP8: Instructions for Using the Side Table:

Open armrest's lid;

Retrieve the side table from the storage compartment inside the armrest.

Rotate the side table until it is fully aligned parallel to the sofa.

