

Assembly Preparation

Owner's Manual

Please check local building codes regarding footings, location and other requirements before beginning construction. Study and understand this owner's manual of important information and helpful tips for easier and more enjoyable assembly.

Assembly instructions:

Reviewing all instructions and the appropriate information before you begin, make sure following the step sequence carefully for successful results.

Flooring base:

Your storage building must be anchored to prevent wind damage and Abased may necessary to construct a square and level building. The base is not included in the kit which may need purchase separately or may construct a foundation and anchoring system of your own. A good location for the storage building is a level area with good drainage.

Parts and Parts List:

Check to be sure that you have all the necessary parts for your building.

Tools you need:

(Please tear off the safety protection layer before the assembly, keep the part number label if needed)

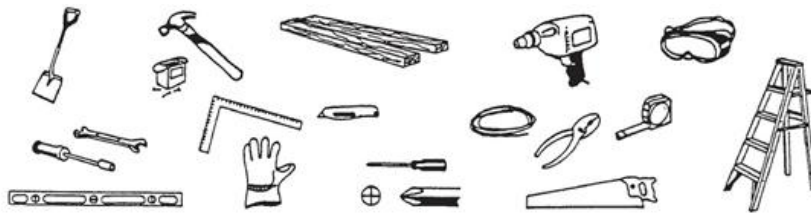

Safety must be put in the No. 1 position:

- 1 Select a dry and calm day for your assembly. Team works (Two or more people) are required during the assembly;
- 2 Wearing safety gloves, eye protection and long sleeves during the assembly to prevent injury; Pay attention to the sharp edge of some parts;
- 3 Children and pets are not allowed entering into the construction site;
- 4 Never concentrate your total weight on the roof of the building. When using a step ladder make sure that it is safety;

Care & Maintenance:

- 1 Keep the shed clean with soft cloth, use water if necessary;
- 2 Keep the door tracks clear of dirt and other stuff that prevent them from sliding easily.
- 3 Clean the snow with necessary tools to make sure it is safe to enter into; Heavy snow may cause collapse, please make sure safety before entering into.
- 4 The shed is not made for living but storing stuff.

Préparation de l'assemblage

Le manuel du propriétaire

Veillez vérifier les codes du bâtiment locaux concernant les semelles, l'emplacement et d'autres exigences avant de commencer la construction. Étudiez et comprenez dans ce manuel d'information les informations importantes et les conseils utiles pour un montage plus facile et plus agréable.

Instructions de montage :

Avant de commencer, passez en revue toutes les instructions et les informations appropriées. Assurez-vous de suivre attentivement la séquence des étapes pour obtenir des résultats satisfaisants.

Base de plancher :

Votre bâtiment de stockage doit être ancré pour éviter les dommages dus au vent et peut être nécessaire d'abaïsser pour construire un bâtiment carré et de niveau. Le socle n'est pas inclus dans le kit, il peut être nécessaire de l'acheter séparément ou vous pouvez construire votre propre système de fondation et d'ancrage. Un bon emplacement pour le bâtiment de stockage est une zone de niveau avec un bon drainage.

Pièces et liste de pièces :

Vérifiez que vous disposez de toutes les pièces nécessaires à votre bâtiment.

Les outils dont vous avez besoin :

(Veillez déchirer la couche de protection avant l'assemblage, conservez l'étiquette du numéro de pièce si nécessaire)



La sécurité doit être votre préoccupation n ° 1 :

- 1 Sélectionnez un jour sec et calme pour votre assemblée. Le travail en équipe (deux personnes ou plus) est requis pendant le montage.
- 2 Porter des gants de protection, des lunettes de protection et des manches longues pendant le montage pour éviter les blessures ; Faites attention au bord tranchant de certaines parties ;
- 3 Les enfants et les animaux domestiques ne sont pas admis sur le chantier de construction.
- 4 Ne concentrez jamais votre poids total sur le toit du bâtiment. Lorsque vous utilisez un escabeau, assurez-vous qu'il est en sécurité.

Entretien et maintenance :

- 1 Gardez la remise propre avec un chiffon doux, utilisez de l'eau si nécessaire ;
- 2 Gardez les rails de la porte exempts de saleté et autres objets qui les empêchent de glisser facilement.
- 3 Nettoyer la neige avec les outils nécessaires pour s'assurer qu'il est sans danger d'entrer ; Une neige abondante peut provoquer un effondrement, assurez-vous de la sécurité avant d'entrer.
- 4 La remise n'est pas faite pour soulever mais pour ranger des objets.

Montaggio

Manuale d'istruzioni

Prima di iniziare, si prega di verificare i regolamenti edilizi locali relativi alle fondamenta, alla posizione e ad altri requisiti. Si prega di studiare e comprendere questo manuale di informazioni importanti e suggerimenti utili per un assemblaggio più semplice.

Istruzioni di assemblaggio:

SI prega di visionare tutte le istruzioni e le informazioni prima di iniziare, accertandosi di seguire attentamente la sequenza di passaggi.

Base pavimento:

Il tuo deposito deve essere ancorato per prevenire danni causati dal vento e potrebbe essere necessario costruire una base quadrata e pianeggiante. La base non è inclusa nel kit, può essere necessario acquistare separatamente o costruire un sistema di fondazione e di ancoraggio. Una buona posizione per la base di stoccaggio è una zona pianeggiante con un buon drenaggio.

Parti:

Controlla di avere tutte le parti necessarie per la costruzione.

Strumenti necessari:

(Si prega di rimuovere la pellicola di protezione prima del montaggio, mantenere l'etichetta del numero di parte, se necessario)

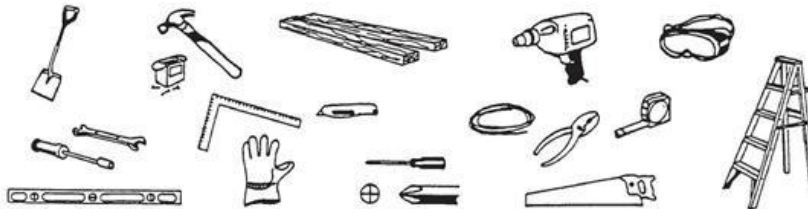

La sicurezza deve venire prima di tutto:

- 1 Scegli un giorno asciutto e calmo per il tuo assemblaggio. Il lavoro di gruppo (due o più persone) è richiesto durante l'assemblaggio;
- 2 Indossare guanti di sicurezza, occhiali protettivi e maniche lunghe durante l'assemblaggio per evitare lesioni. Prestare attenzione al bordo tagliente di alcune parti;
- 3 Ai bambini e agli animali domestici non è consentito entrare nel cantiere;
- 4 Non concentrare mai il peso totale sul tetto dell'edificio. Quando si utilizza una scala a pioli, assicurarsi che sia sicura;

Manutenzione:

- 1 Tenere il capanno pulito con un panno morbido, usare acqua se necessario;
- 2 Tenere i binari della porta liberi da sporcizia e altre cose che impediscano loro di scivolare facilmente.
- 3 Pulisci la neve con gli strumenti necessari per assicurarti che sia sicuro entrare; La neve pesante può causare il collasso, controlla che sia sicuro prima di entrare.
- 4 Il capanno non è ideato come zona abitativa, ma solo come magazzino.

Size:

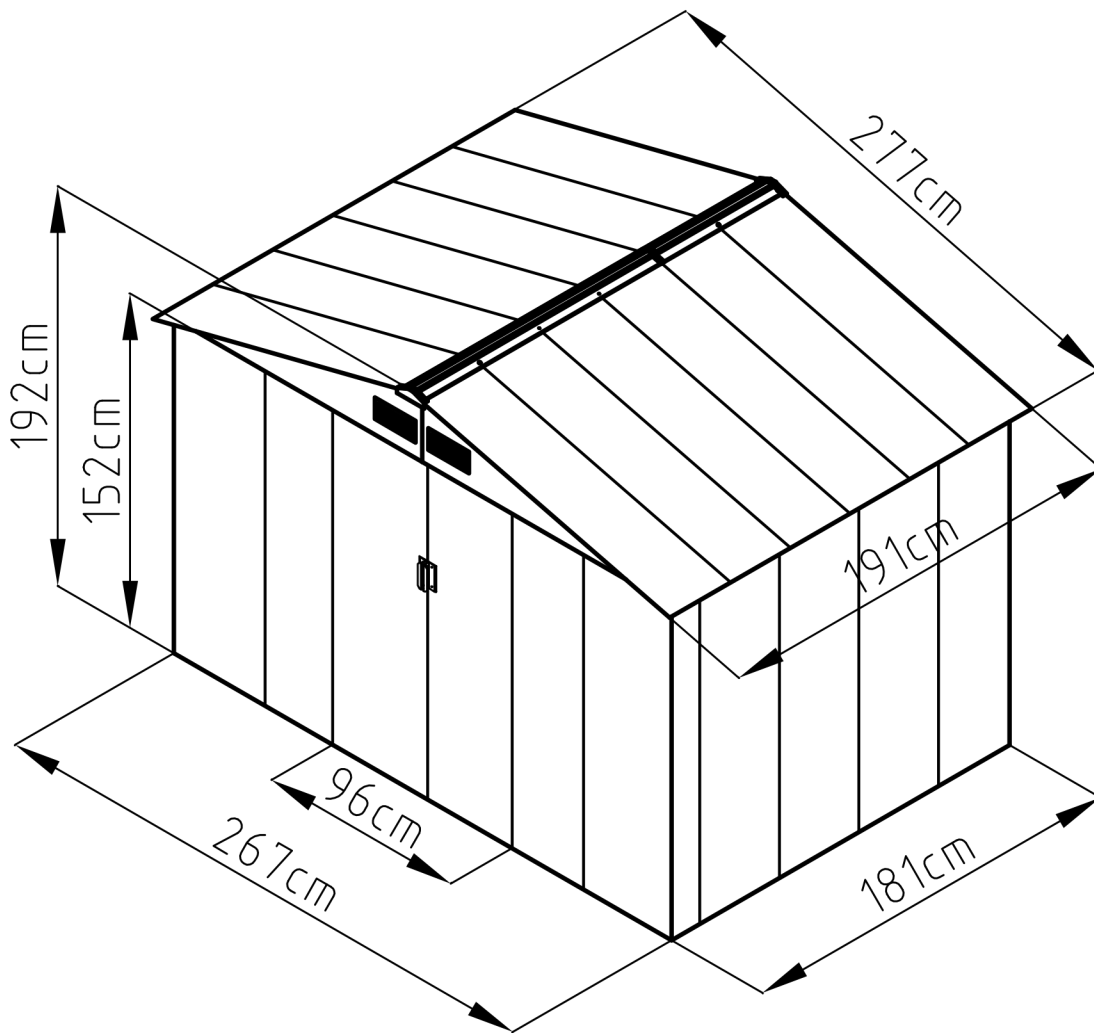

Area of installation requirement:

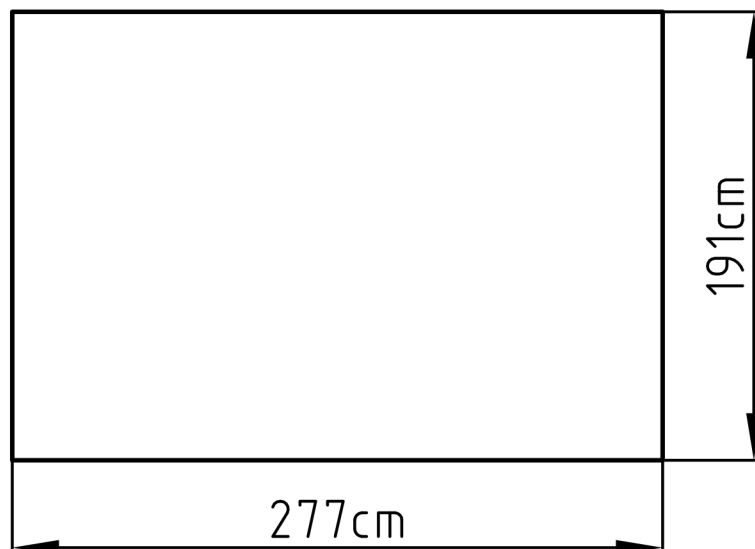

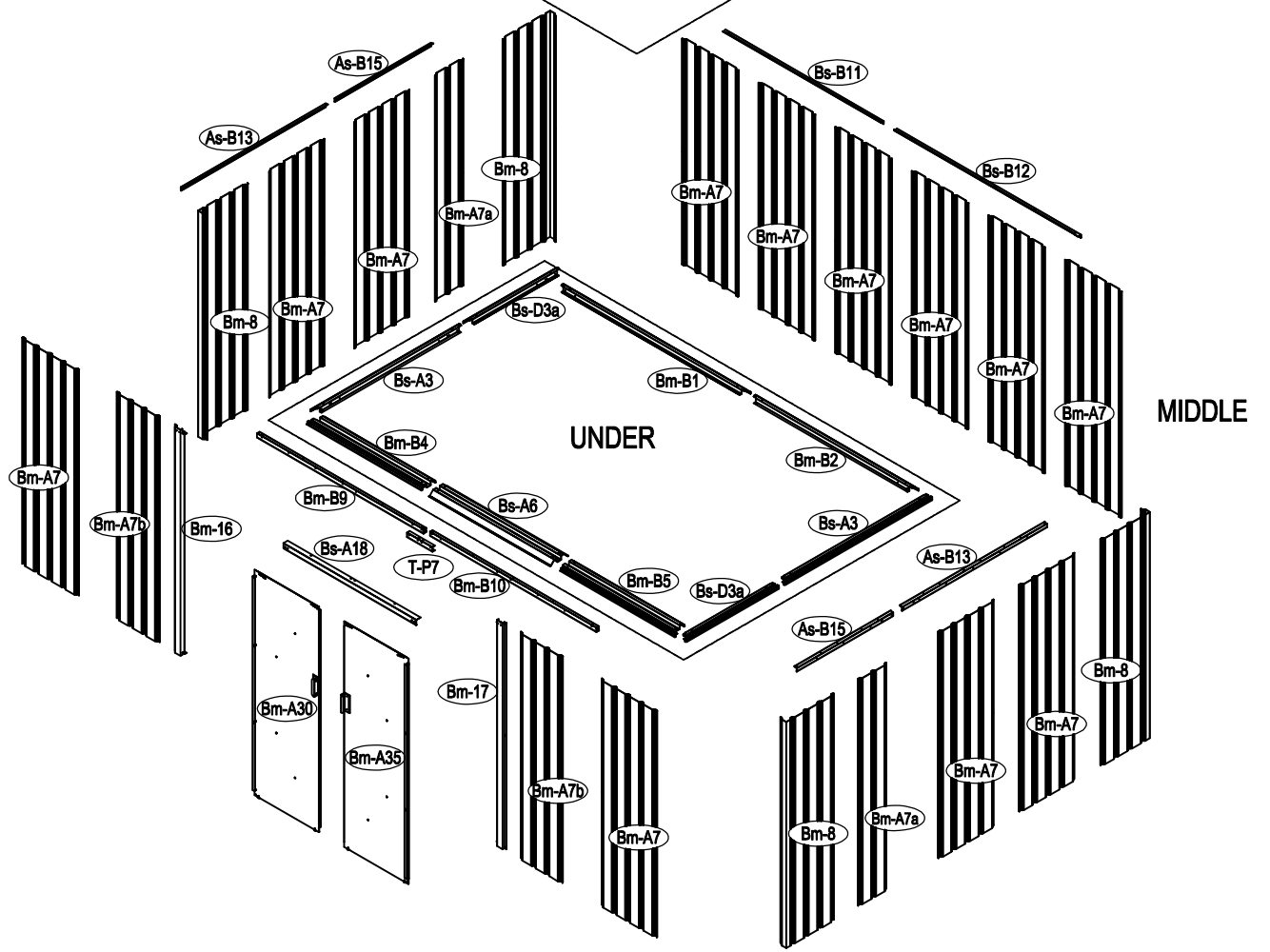
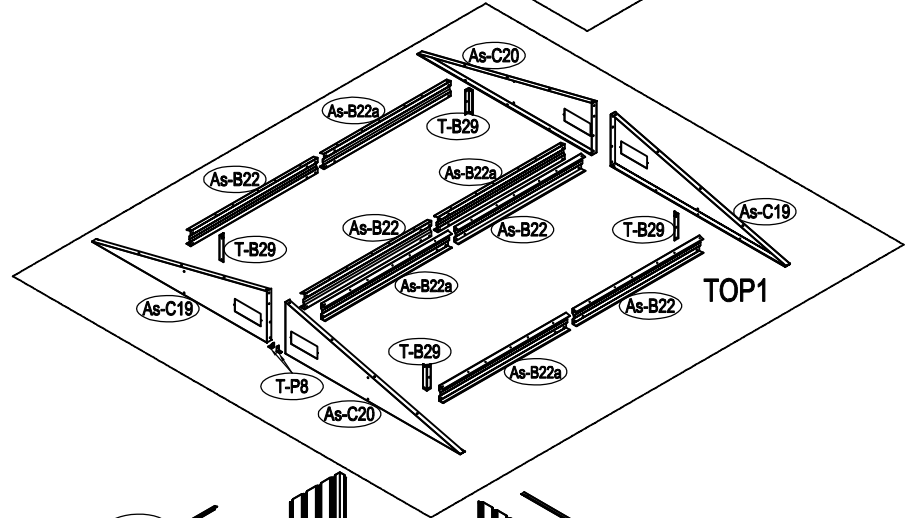
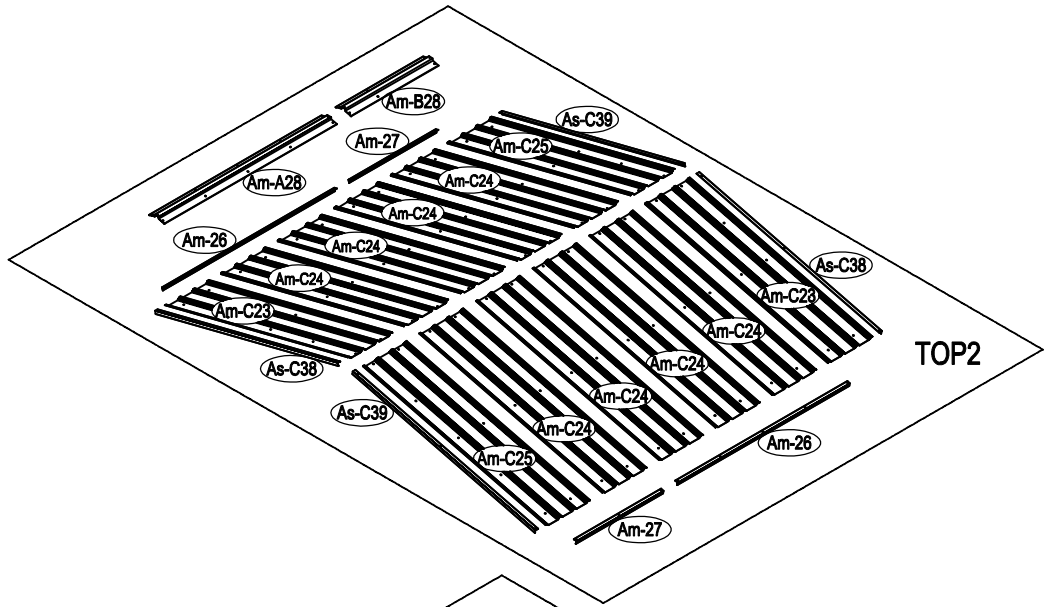

1

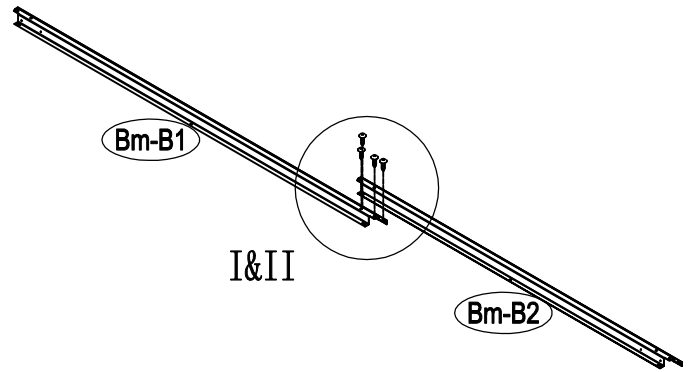
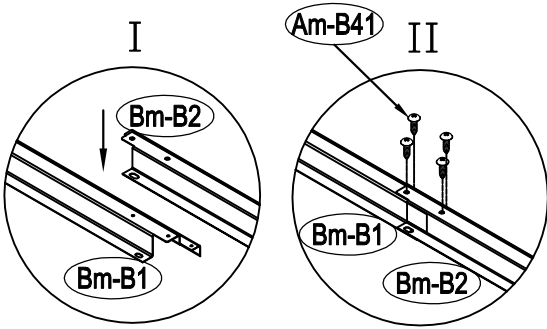

2

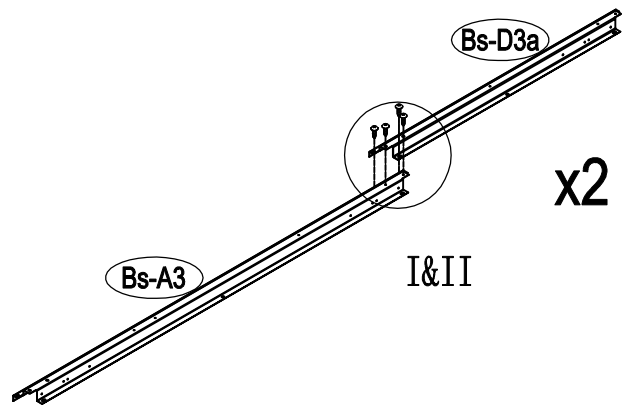
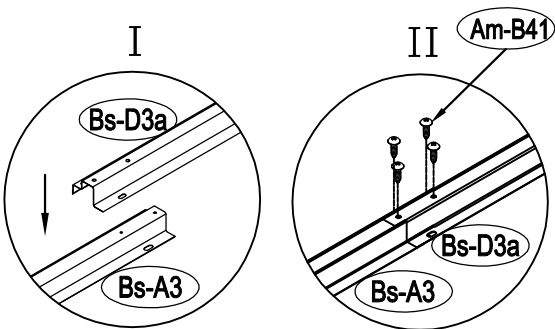

3

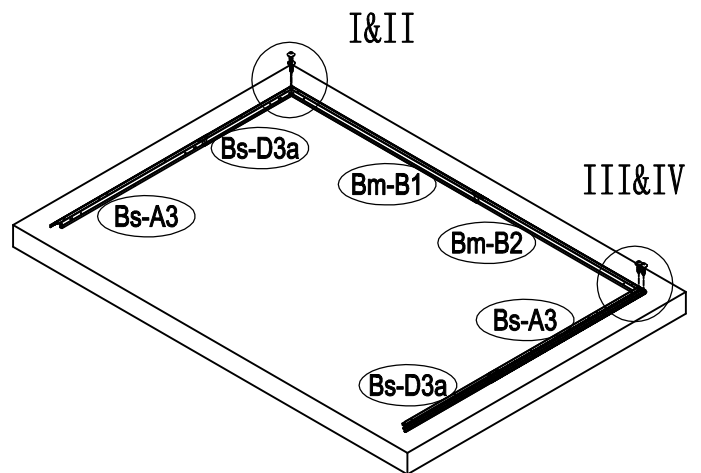
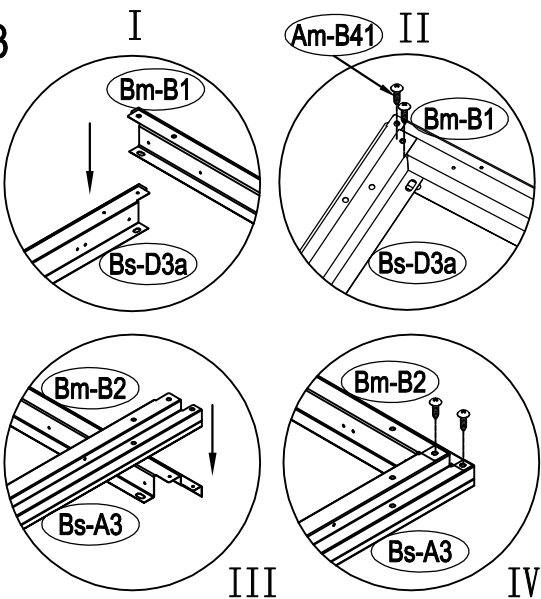

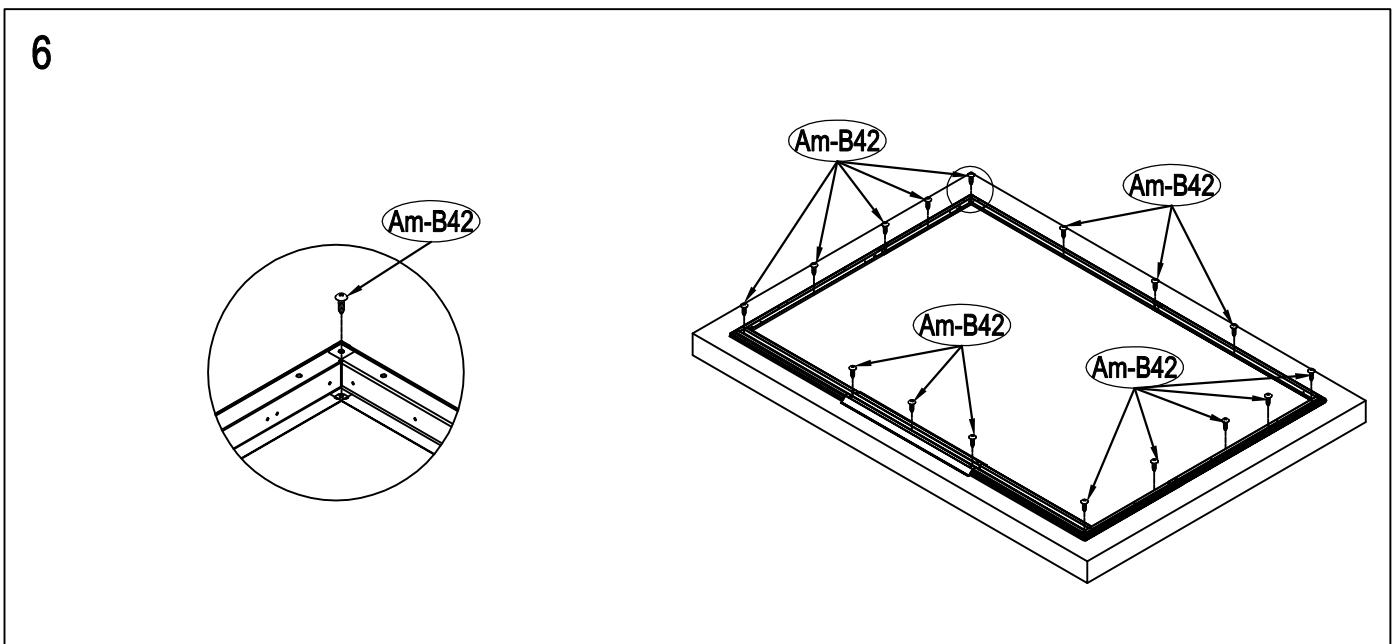
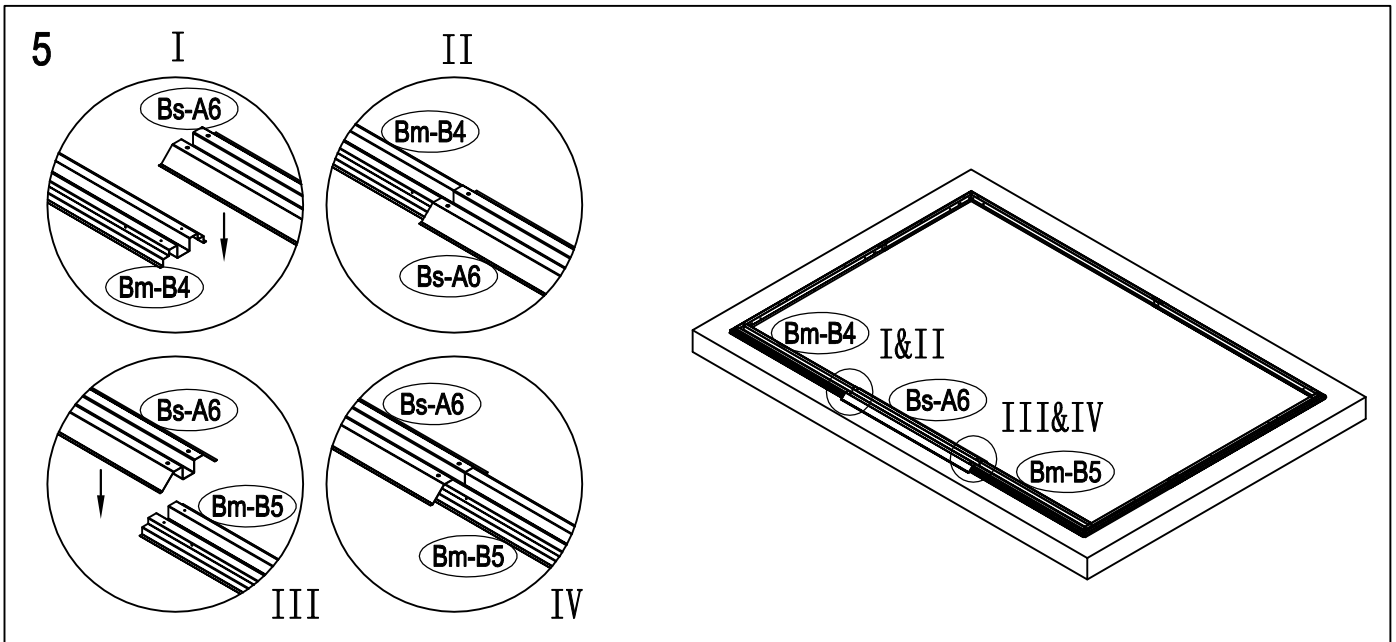
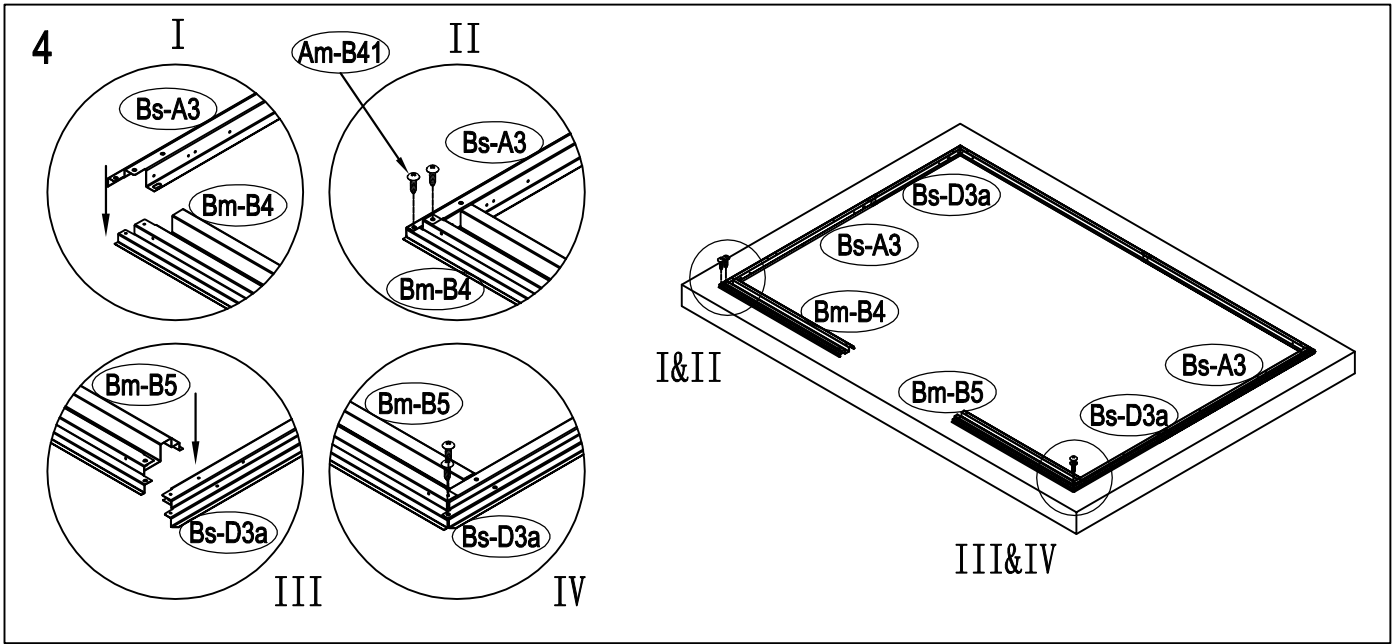

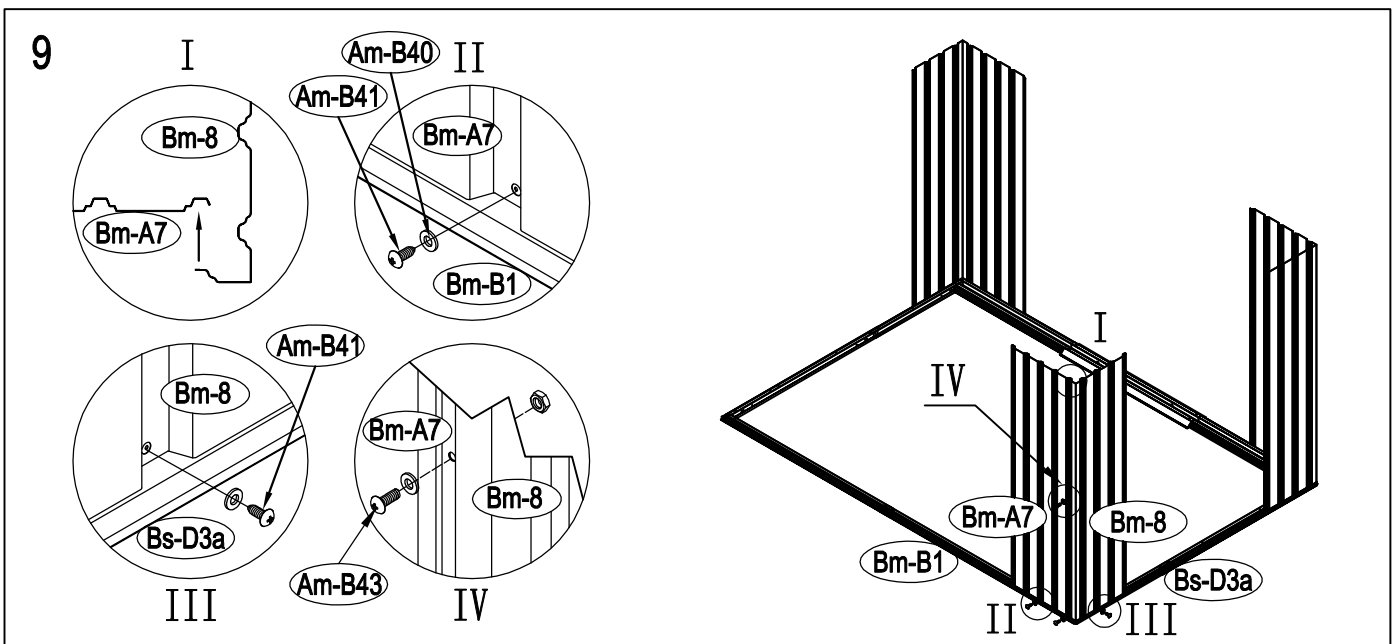
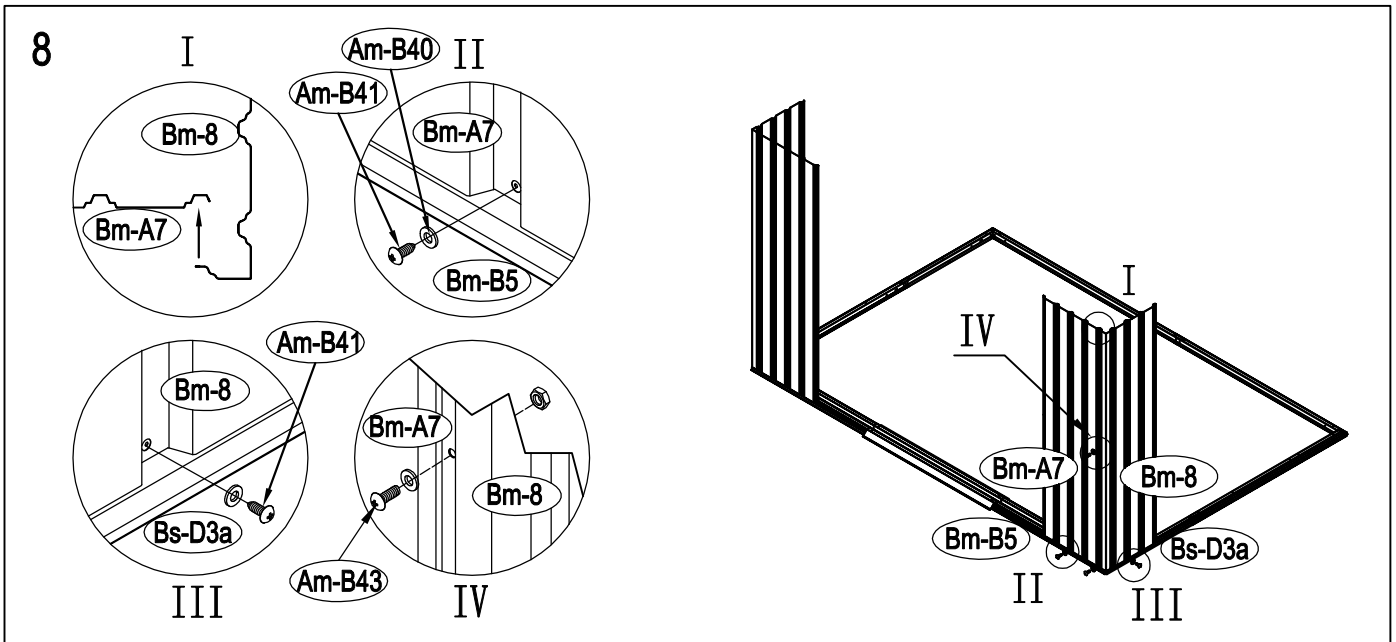
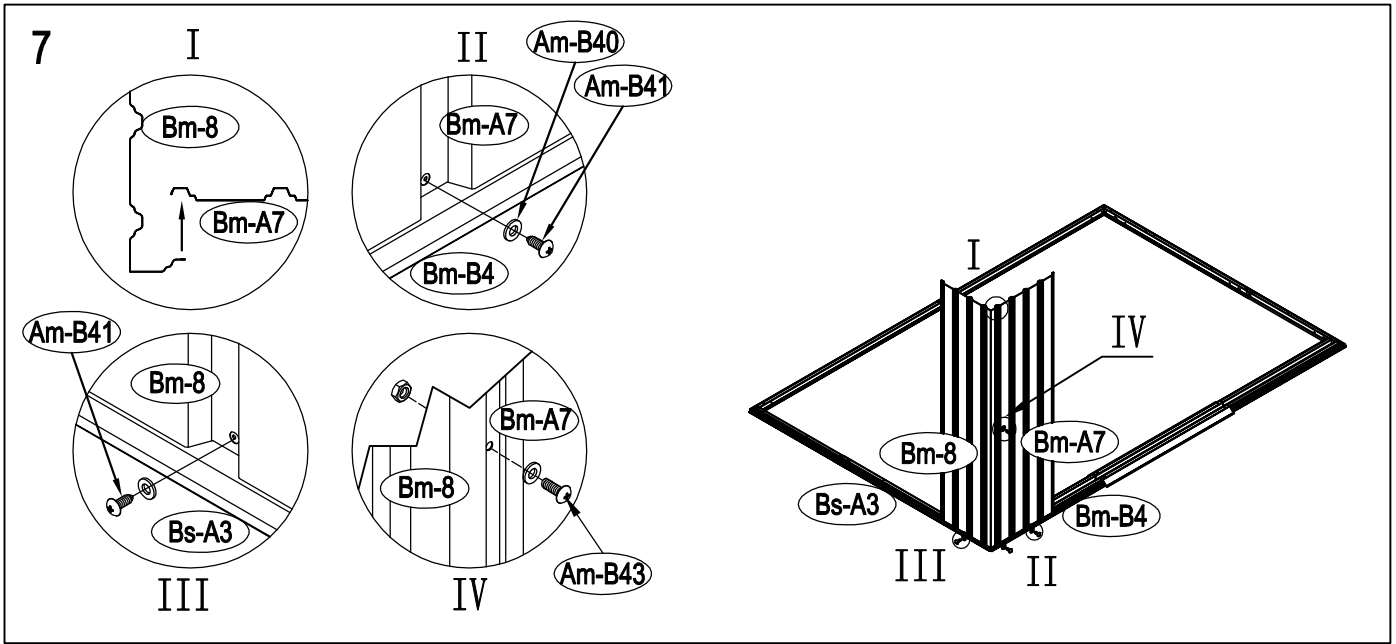

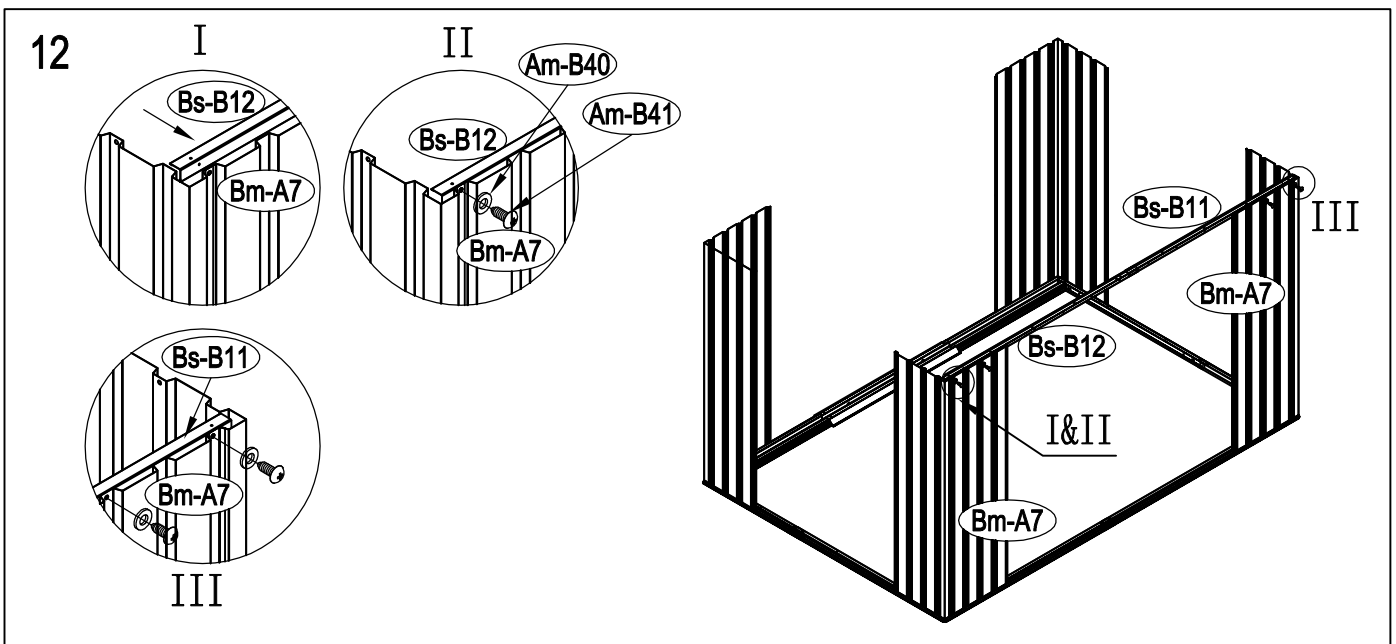
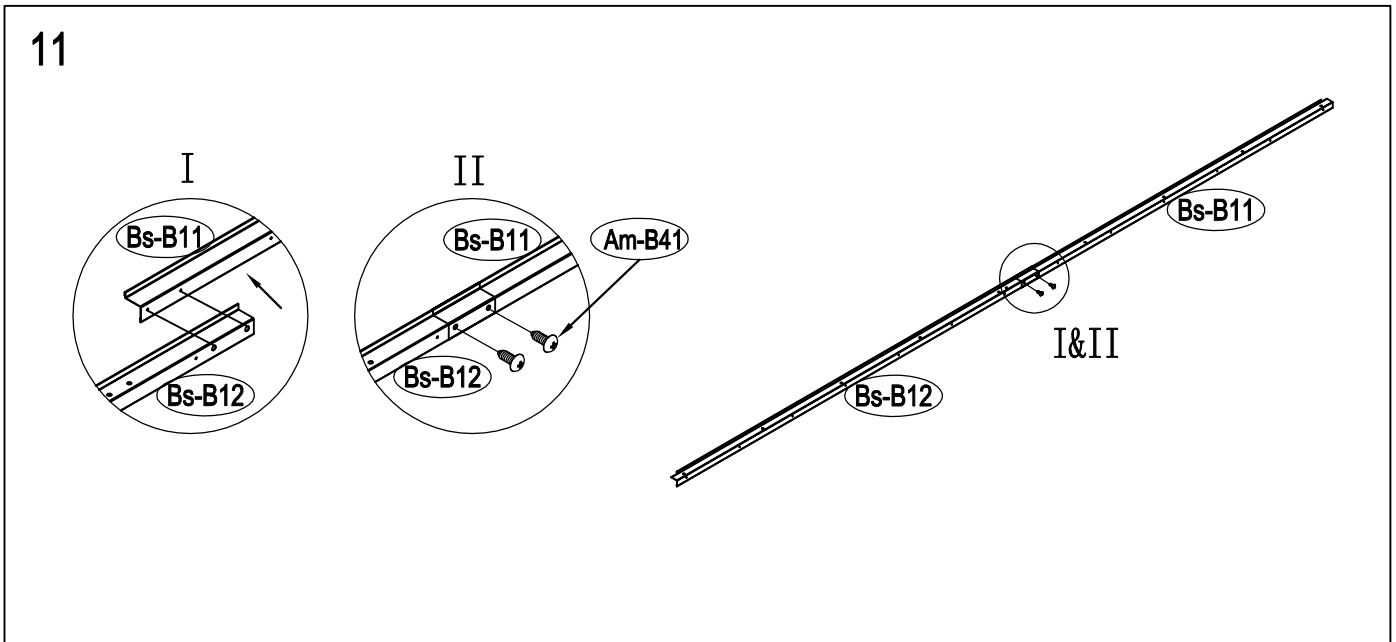
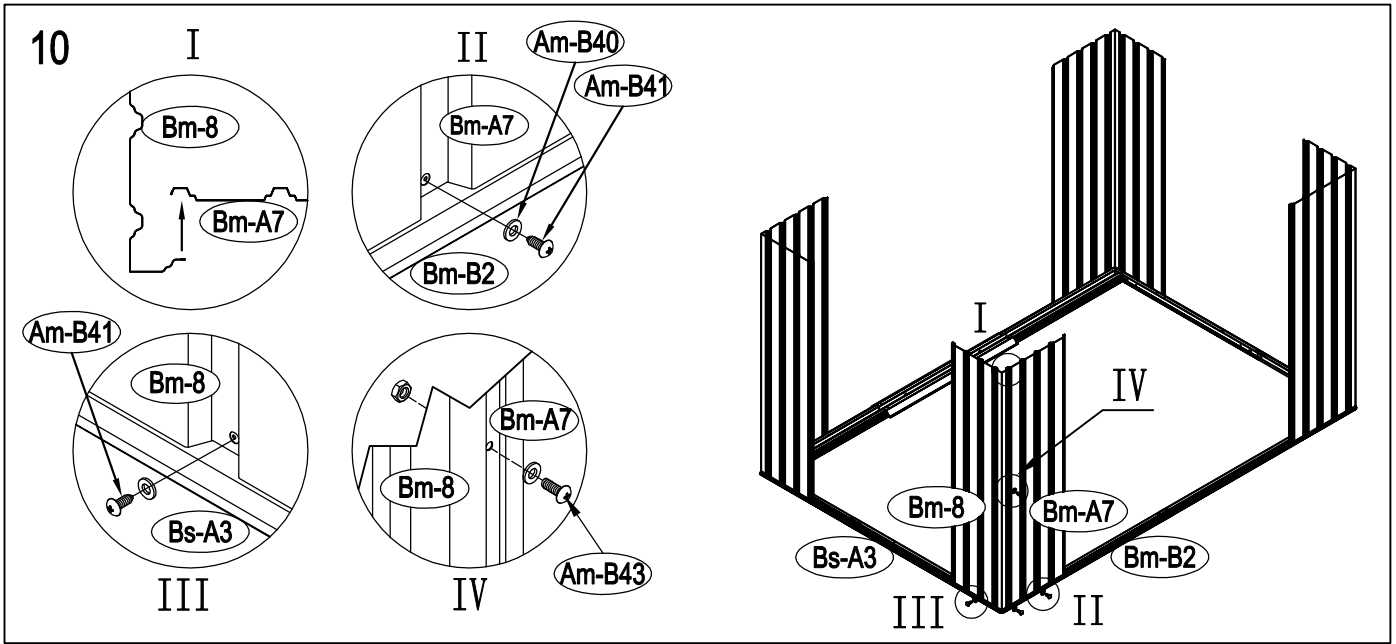

13

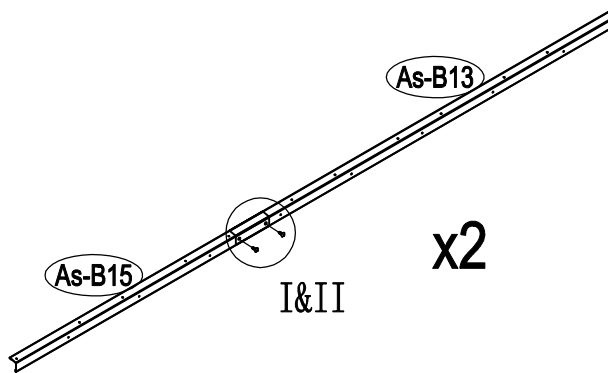
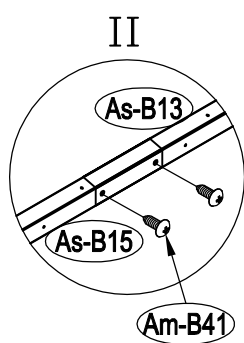
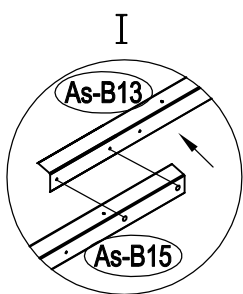

14

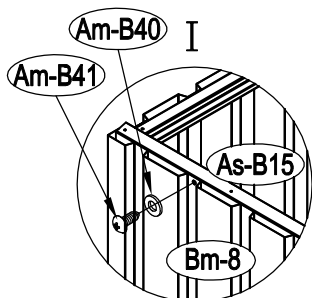

x2

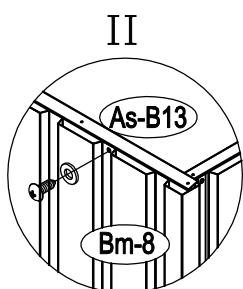

x2

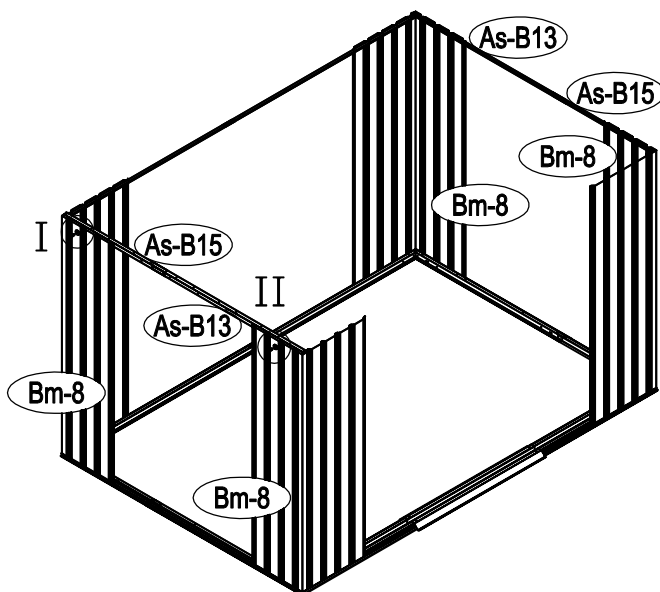

15

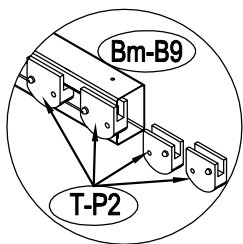
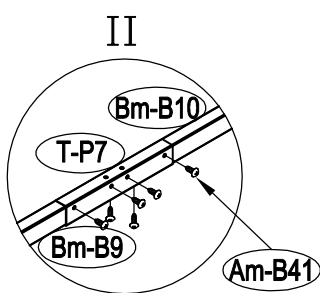
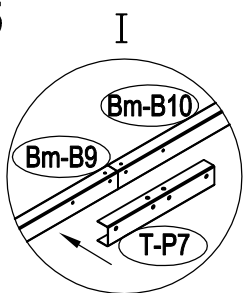

III

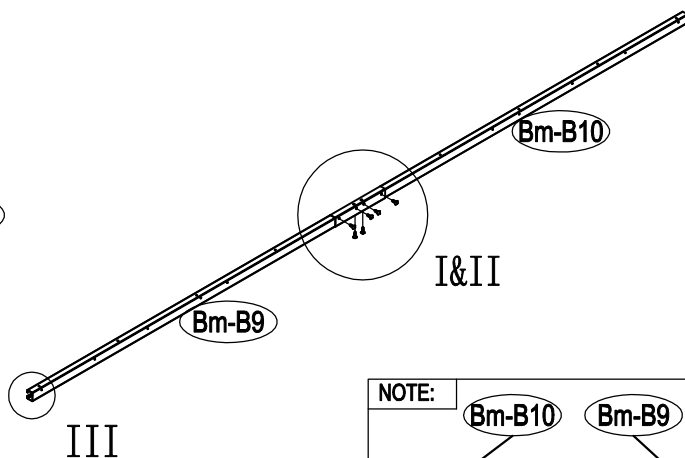

NOTE:

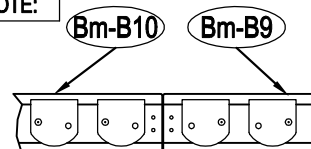

16

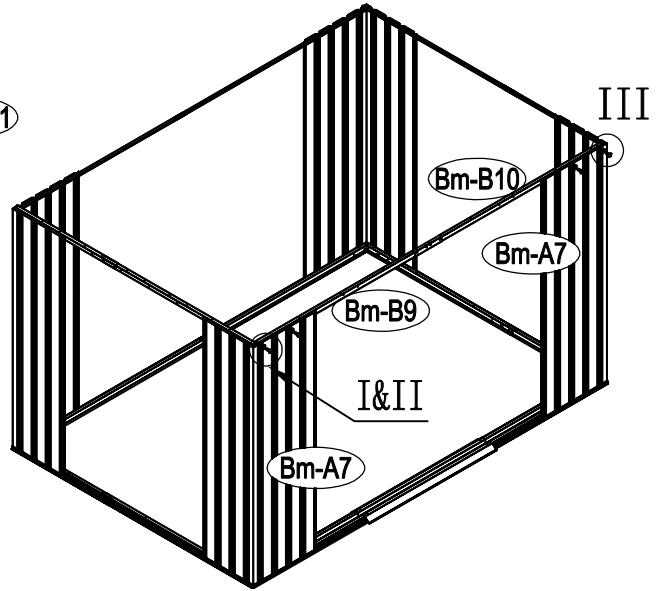
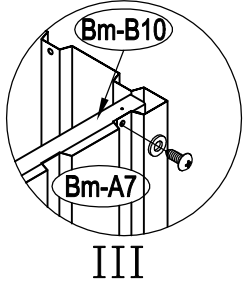
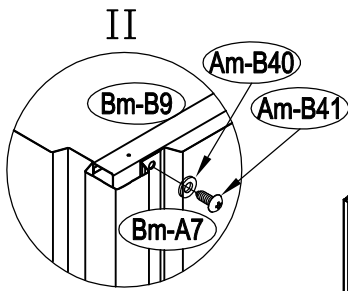
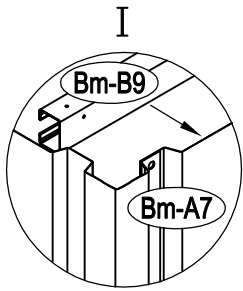

17

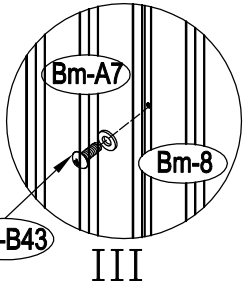
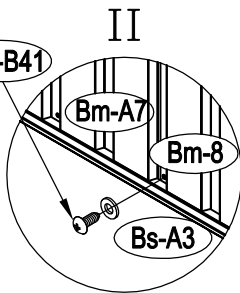
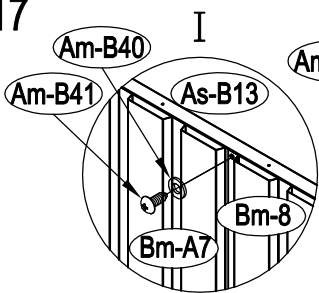

x4

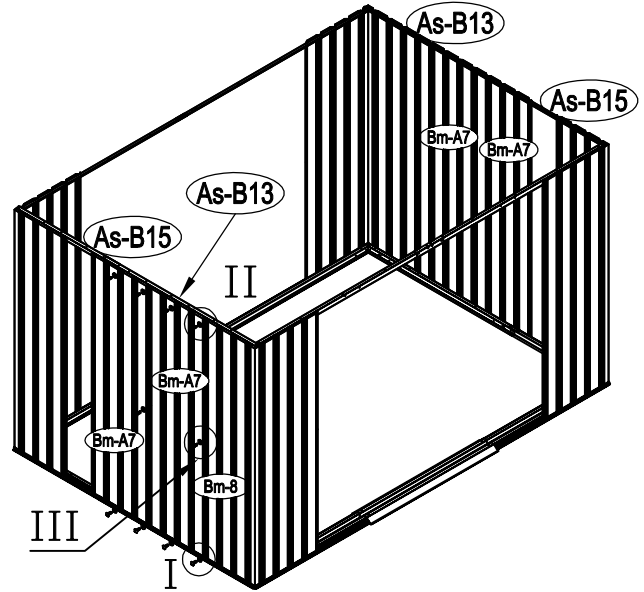

18

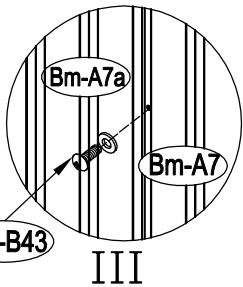
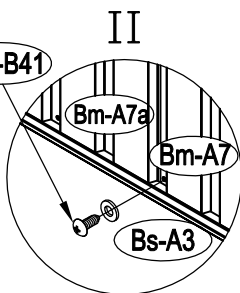
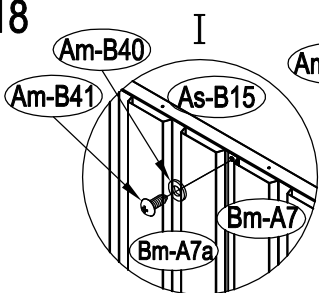

x2

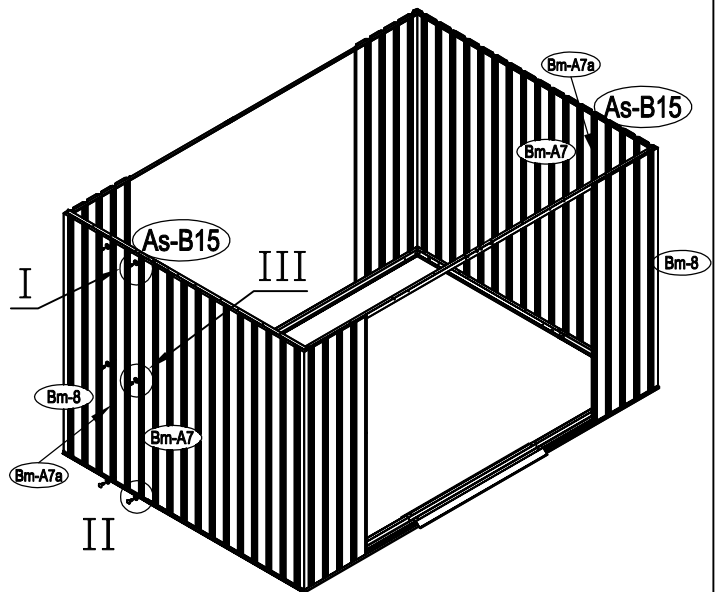

19

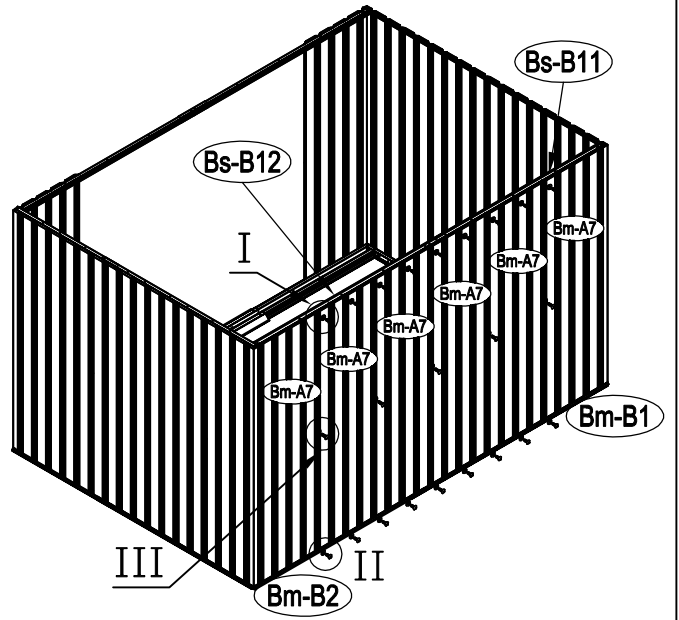
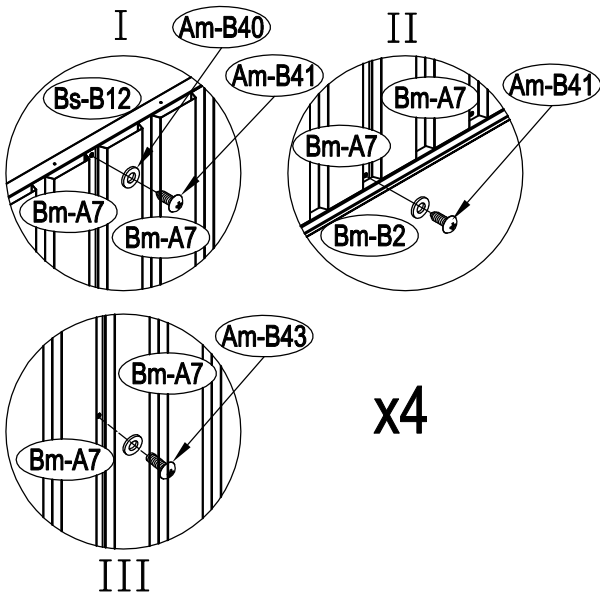

20

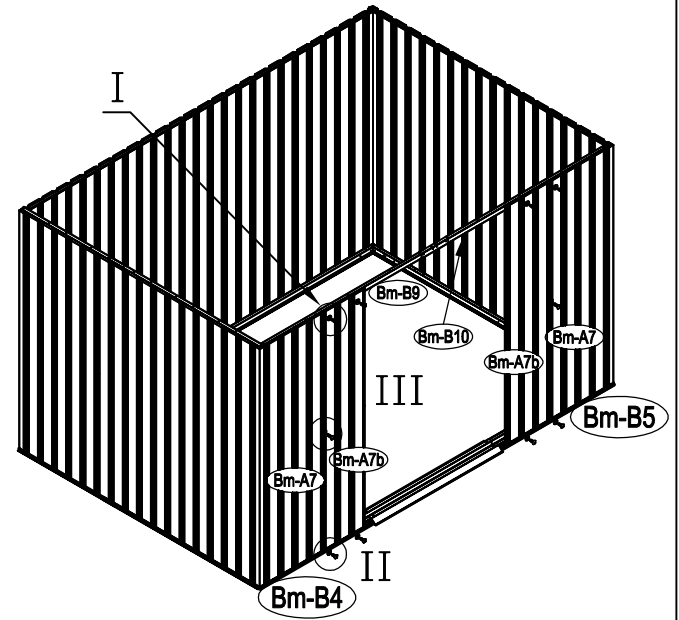
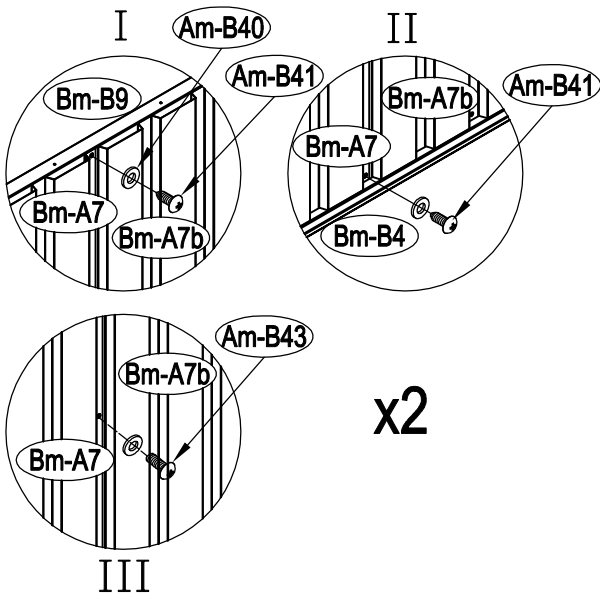

21

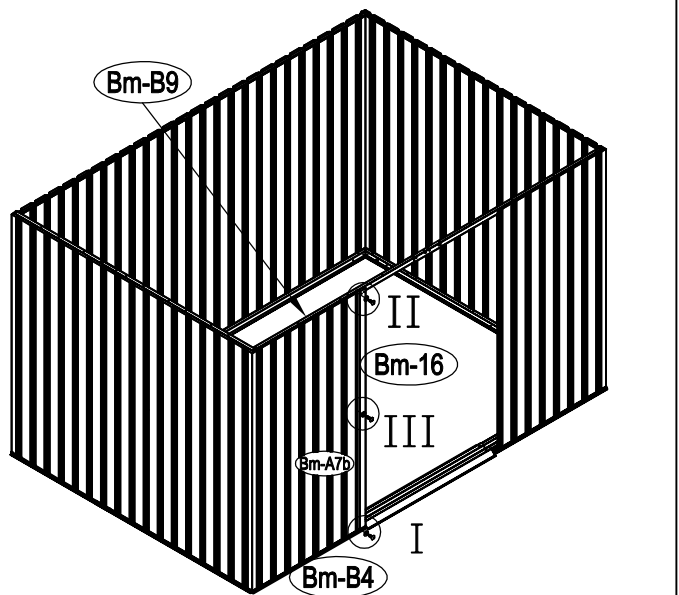
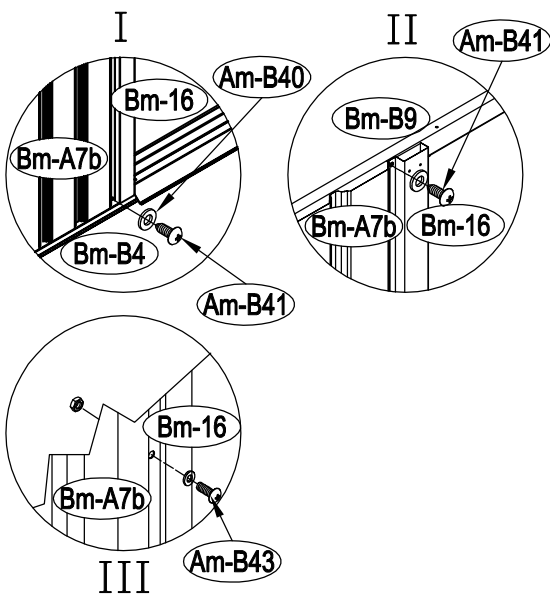

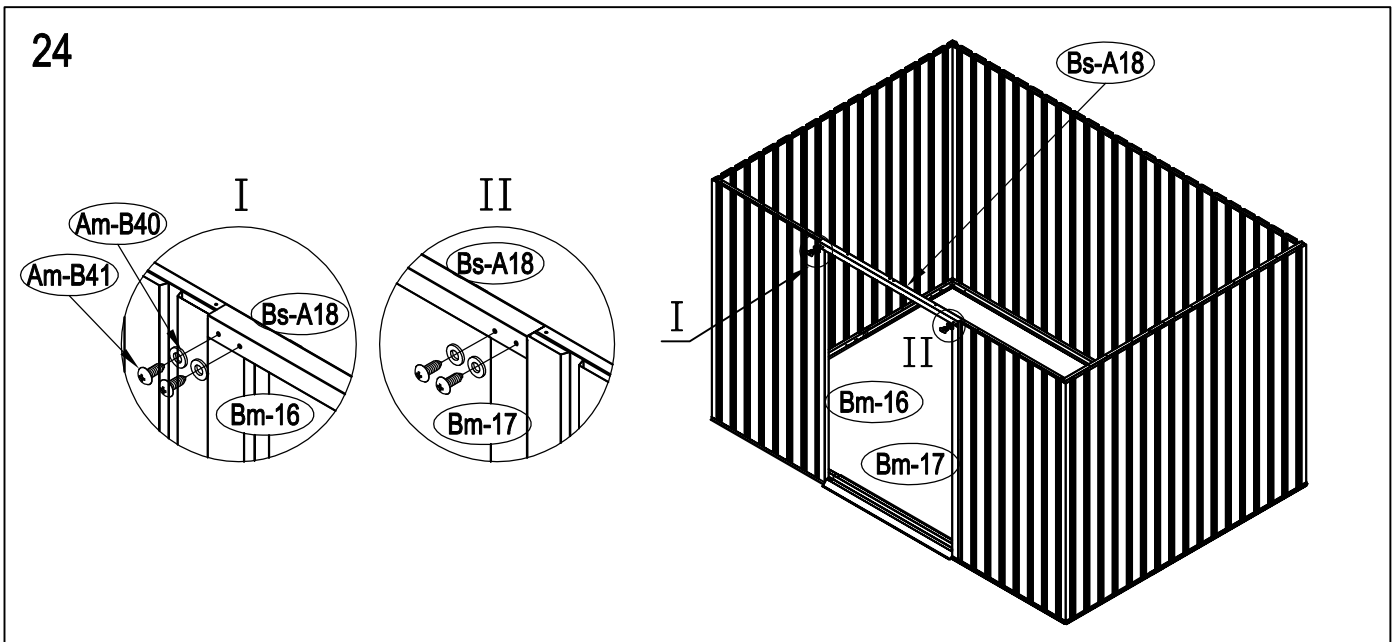
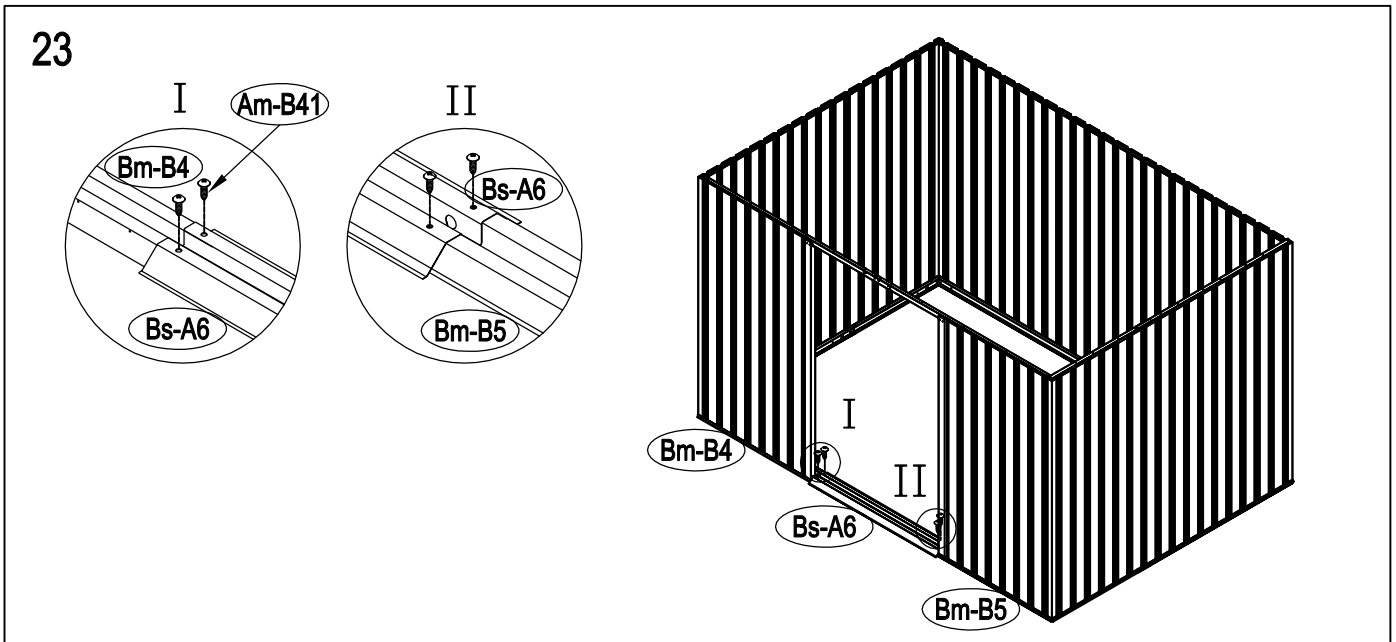
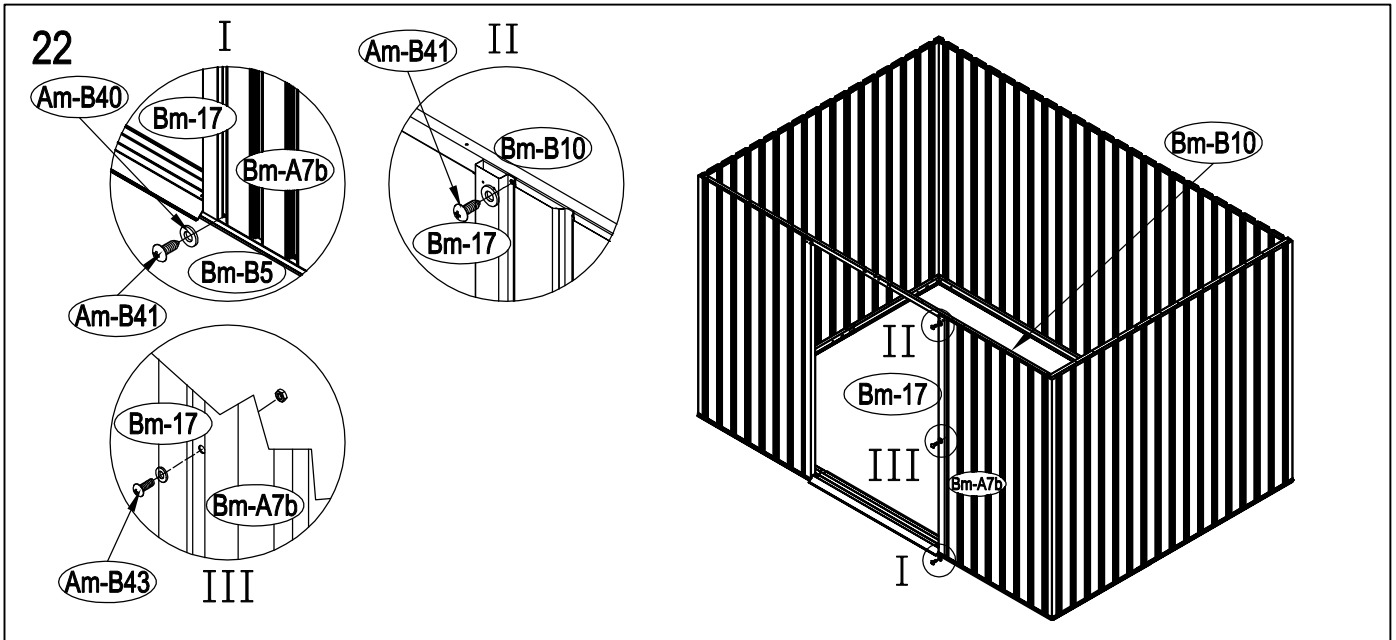

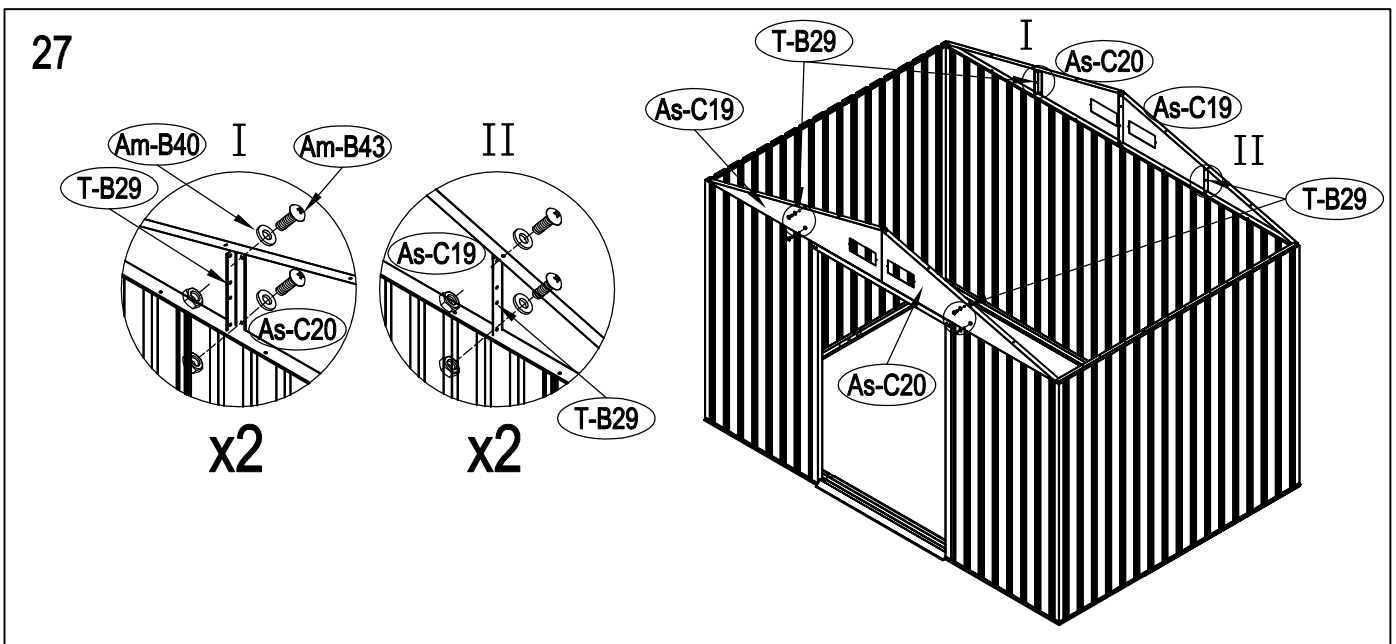
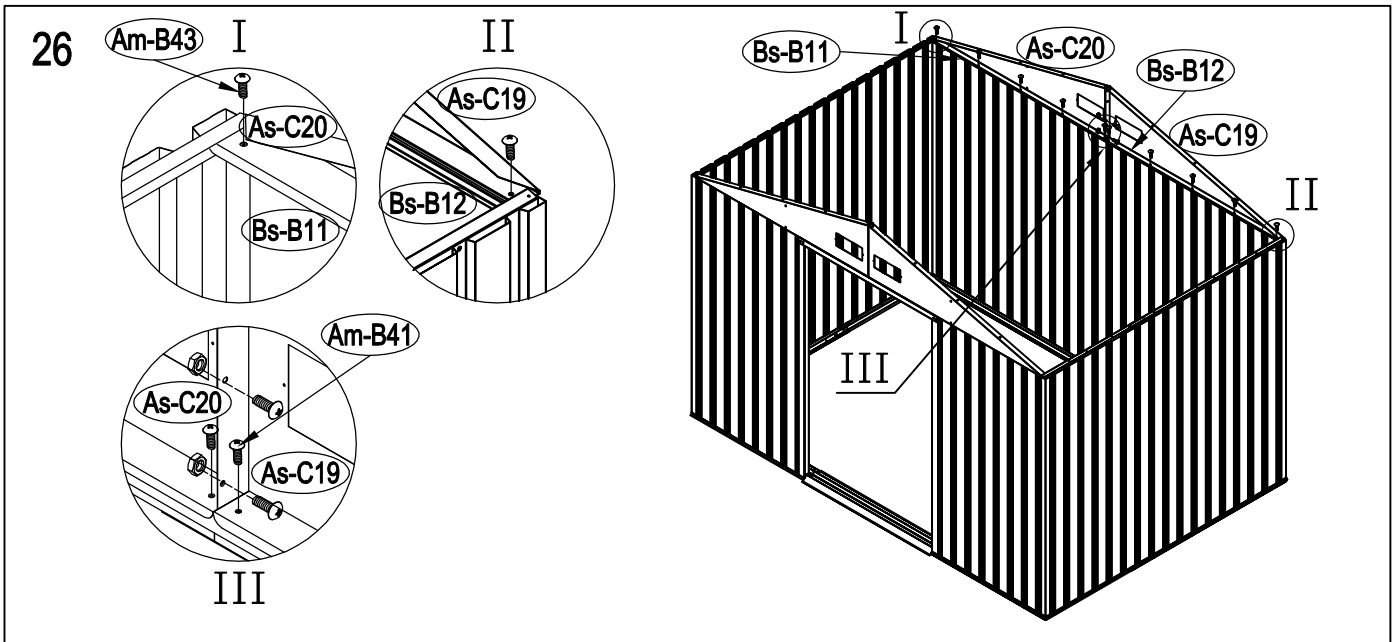
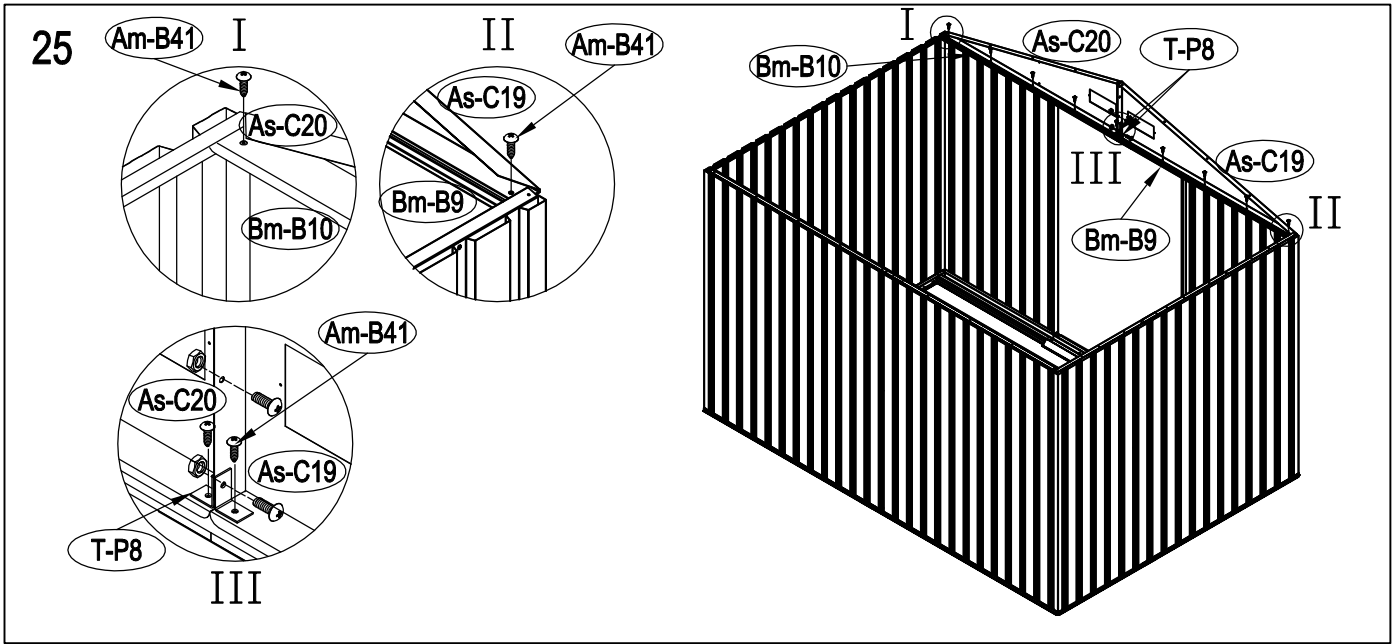

28

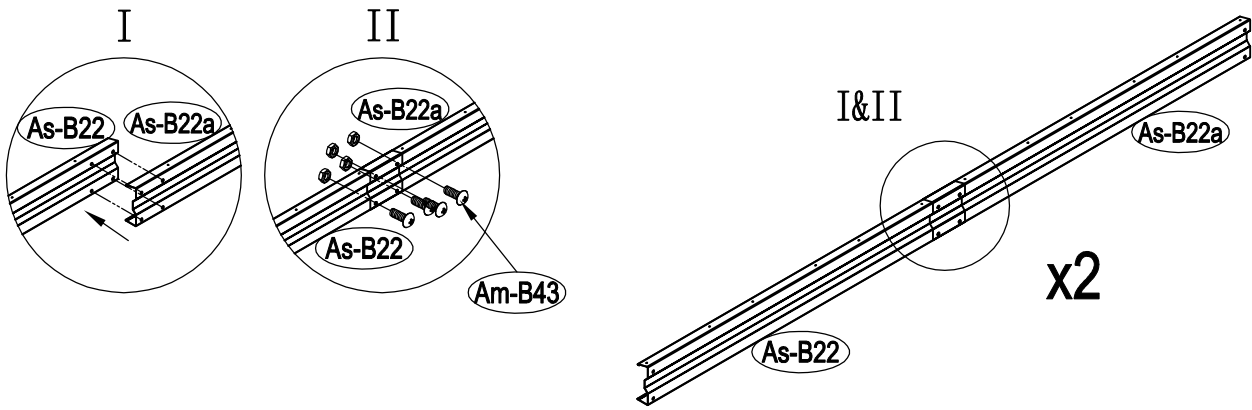

29

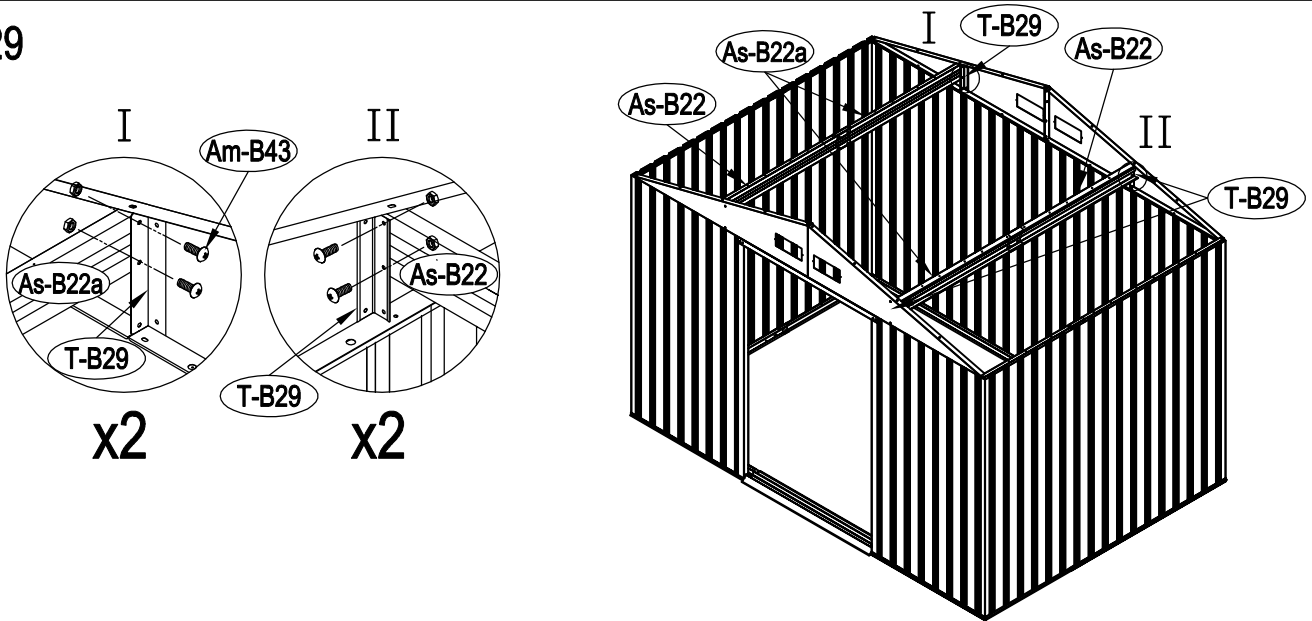

30

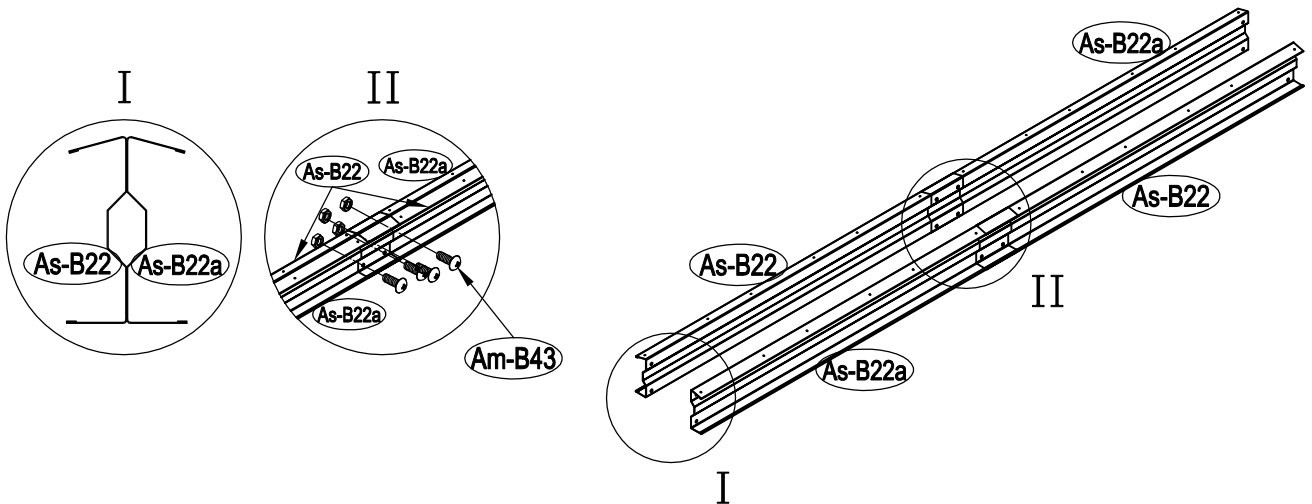

31

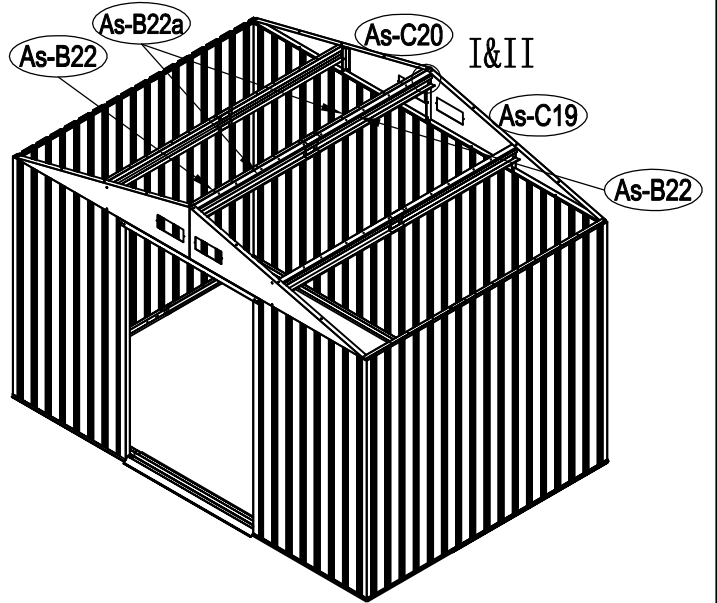
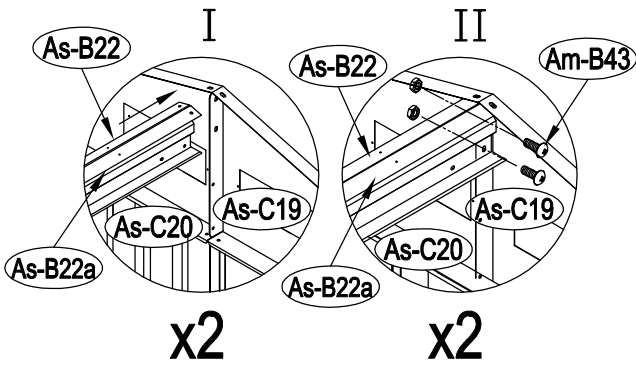

32

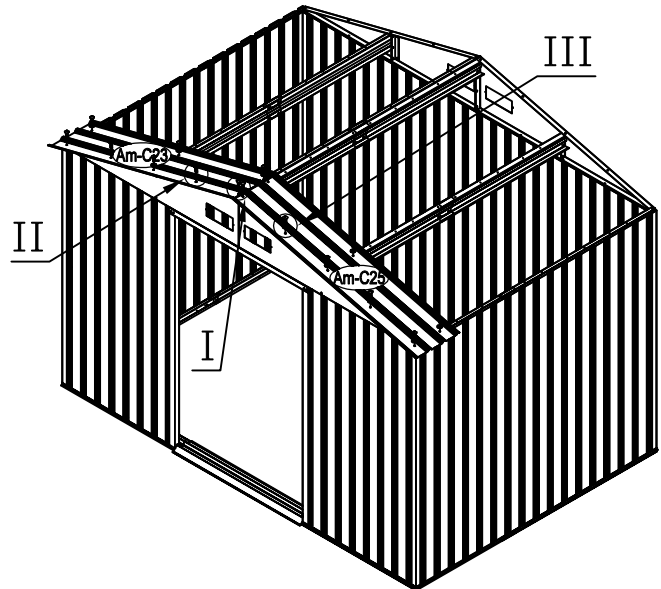
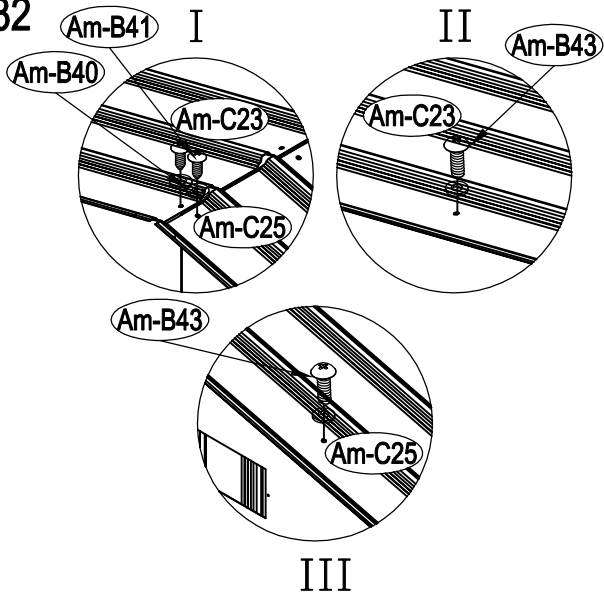

33

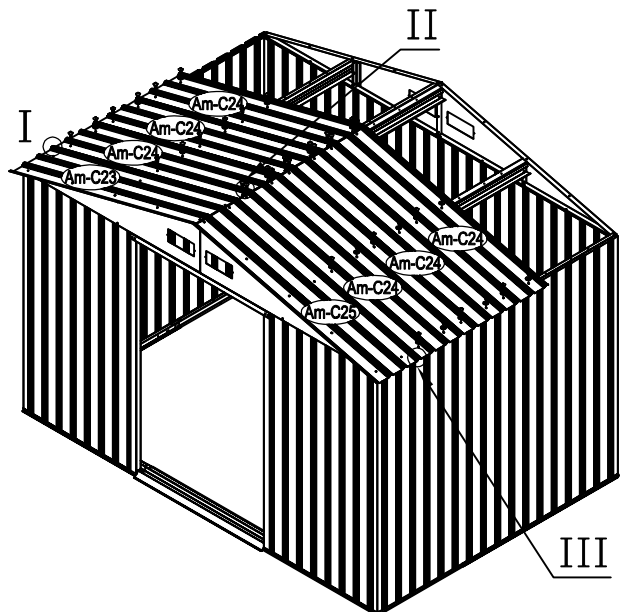
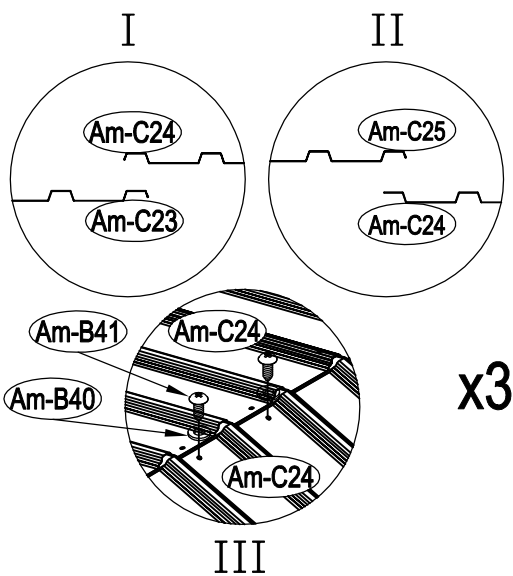

34

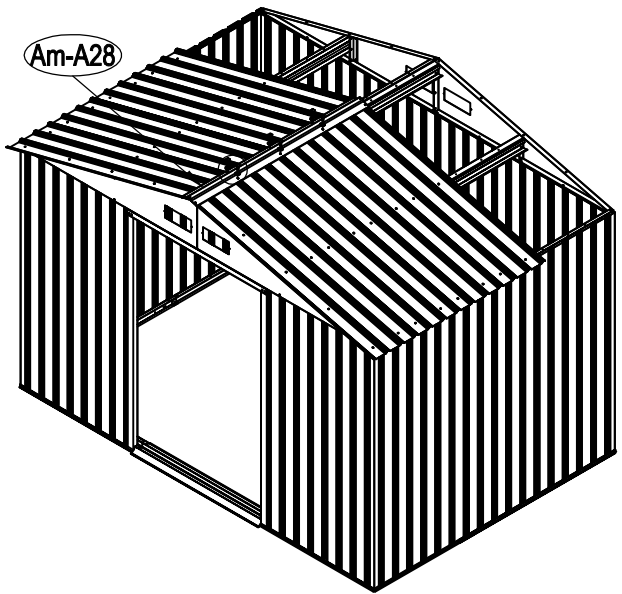
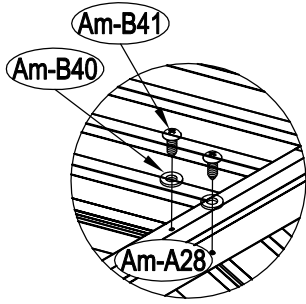

35

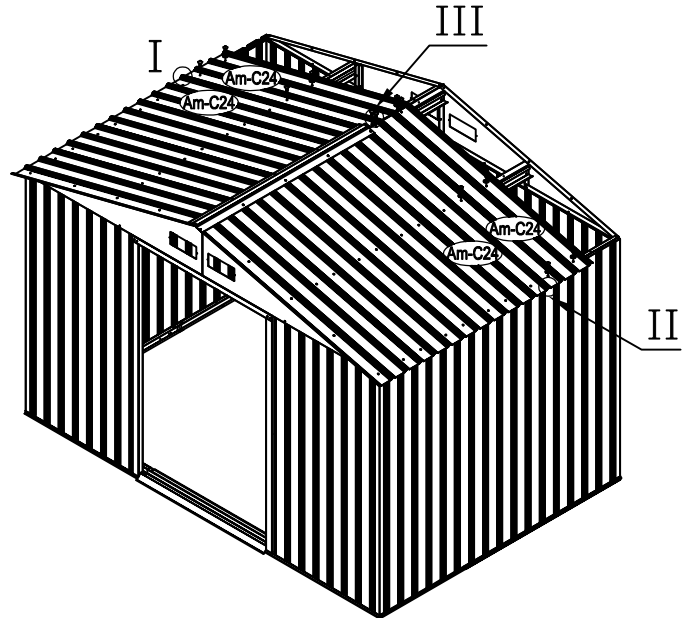
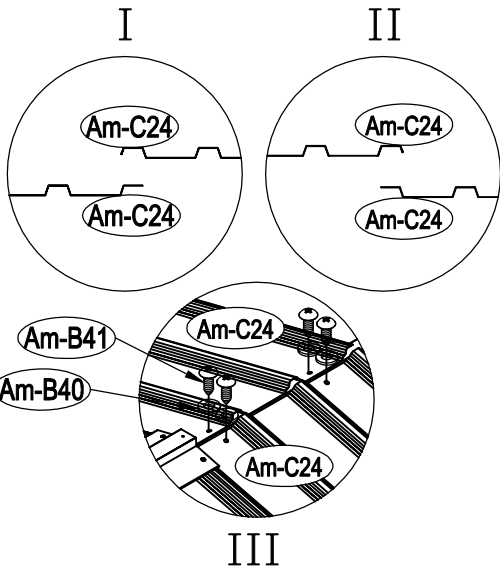

36

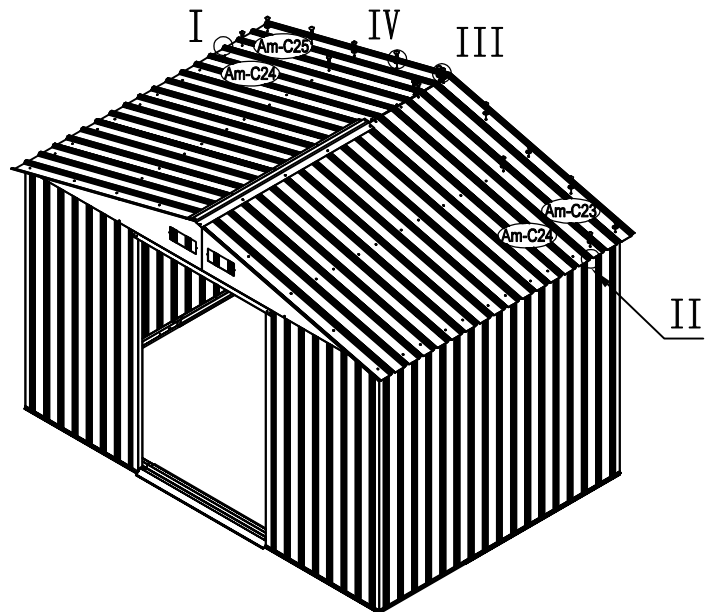
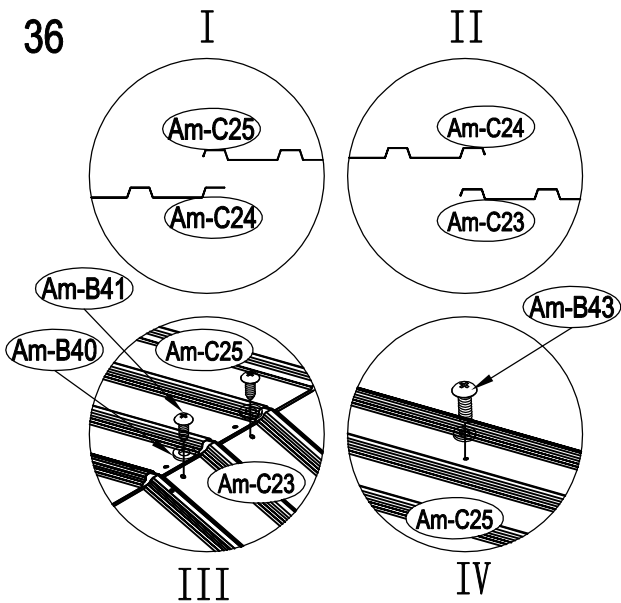

37

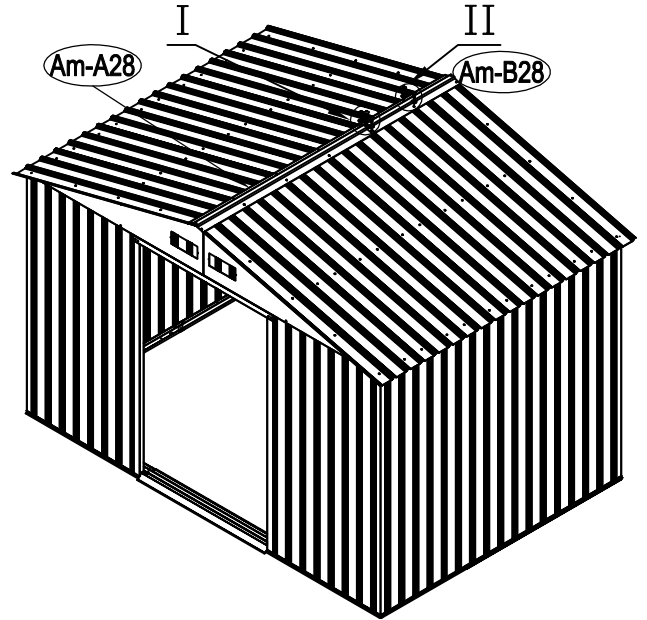
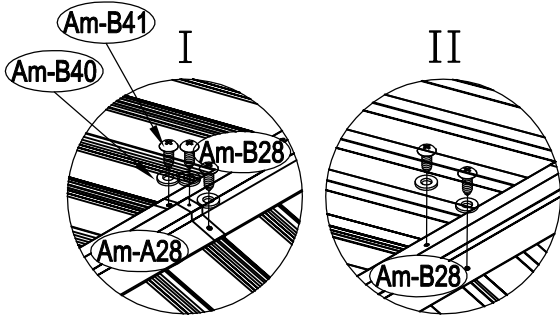

38

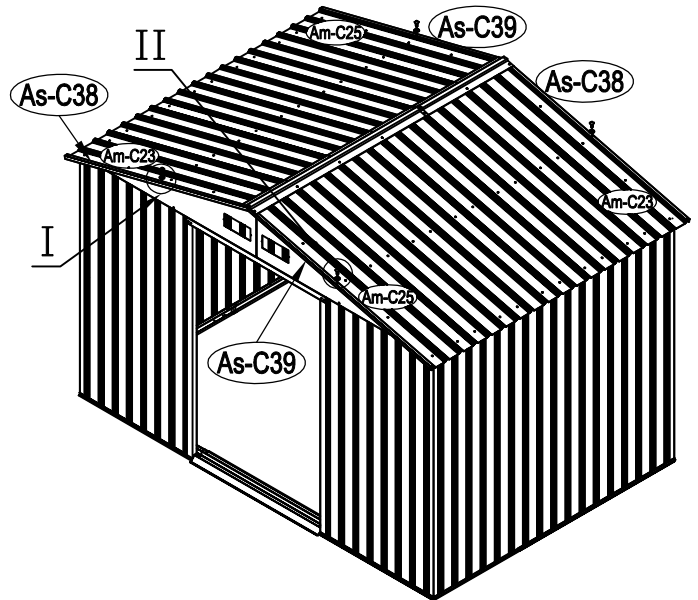
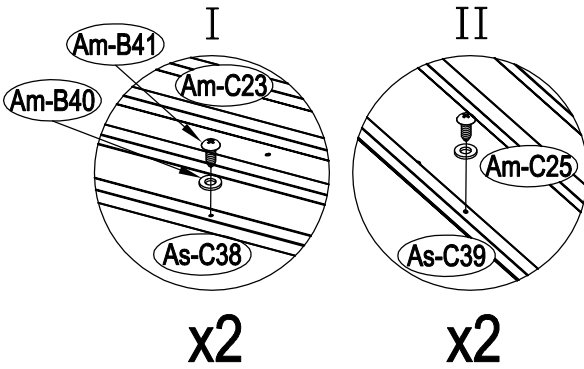

39

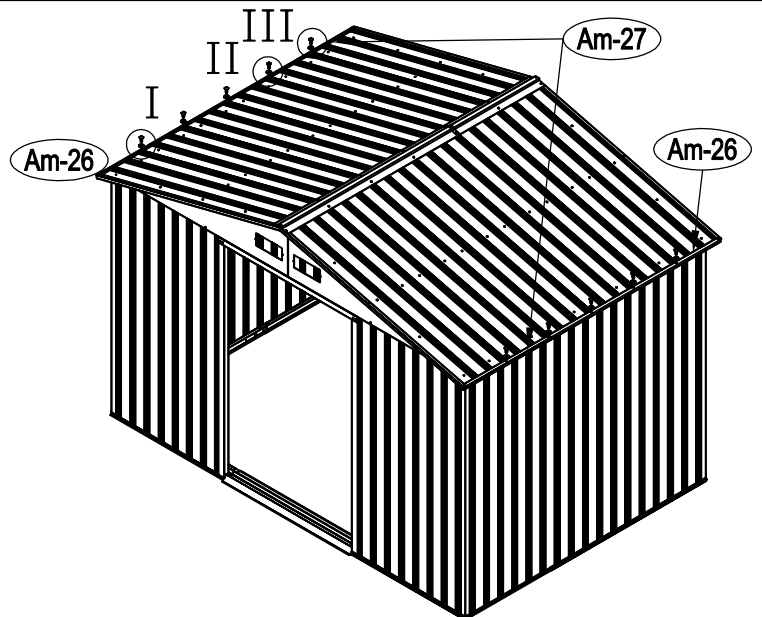
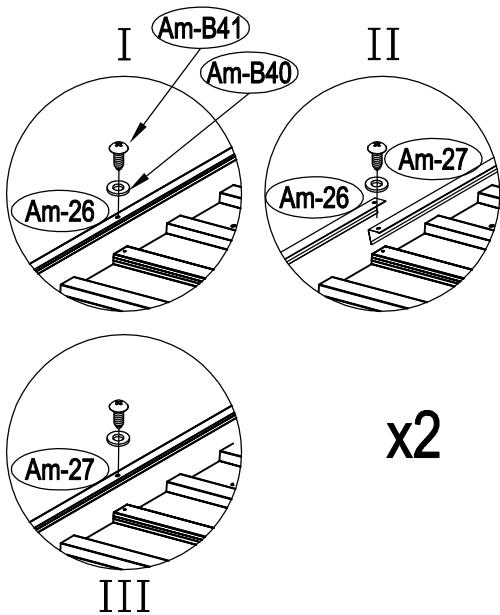

40

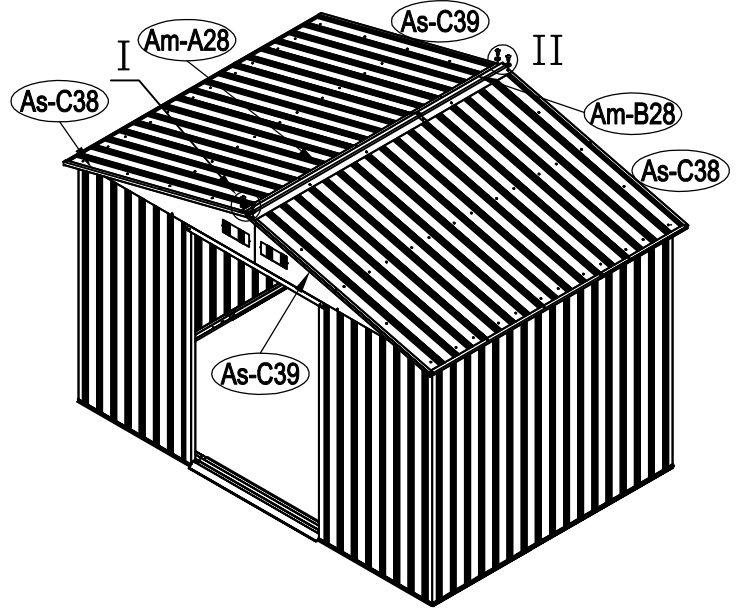
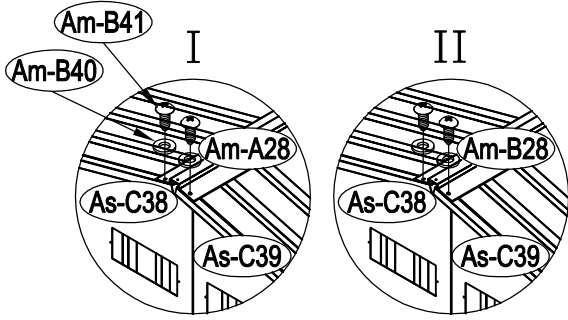

41

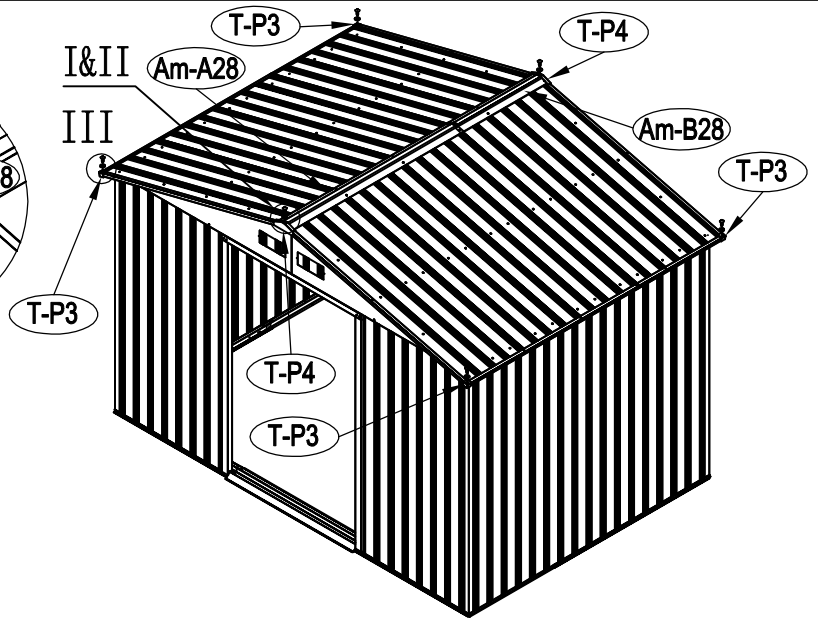
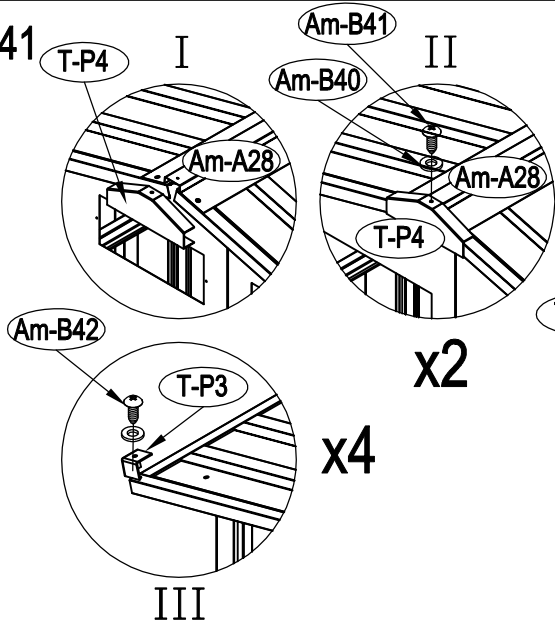

42

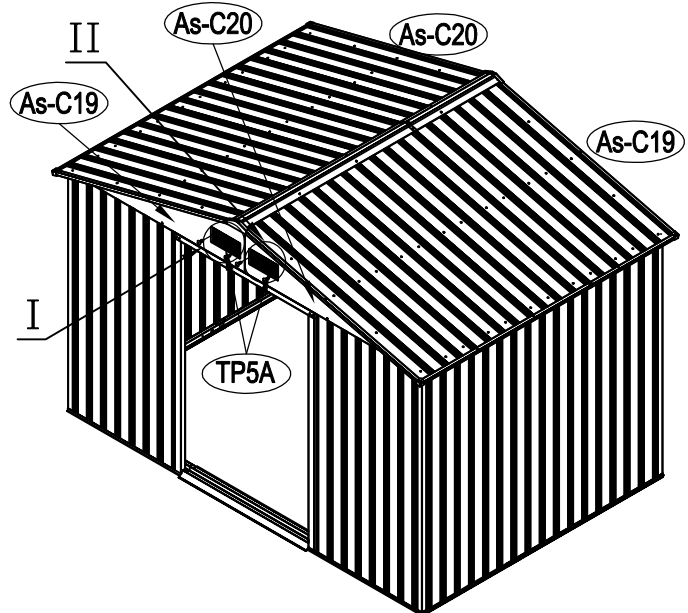
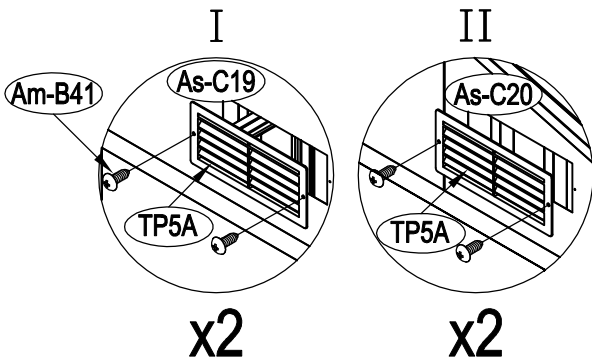

43

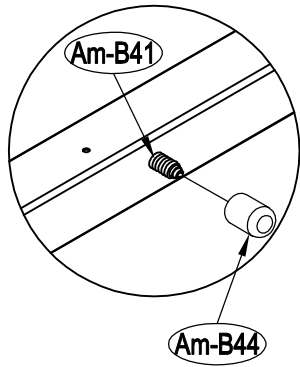

x133

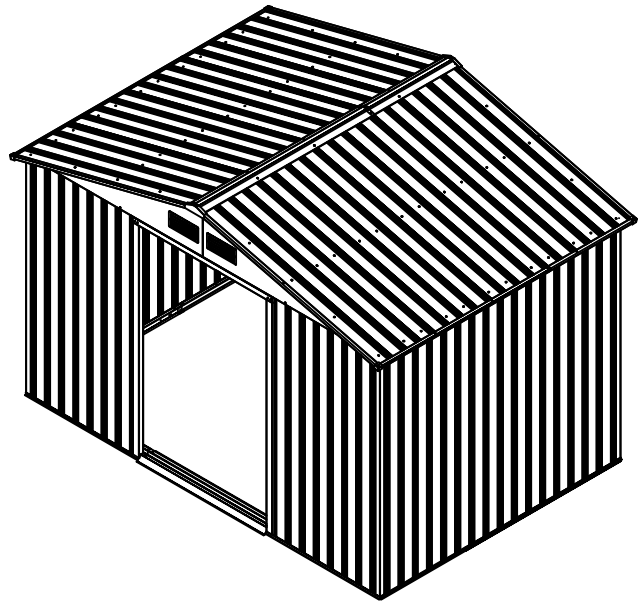

DOOR

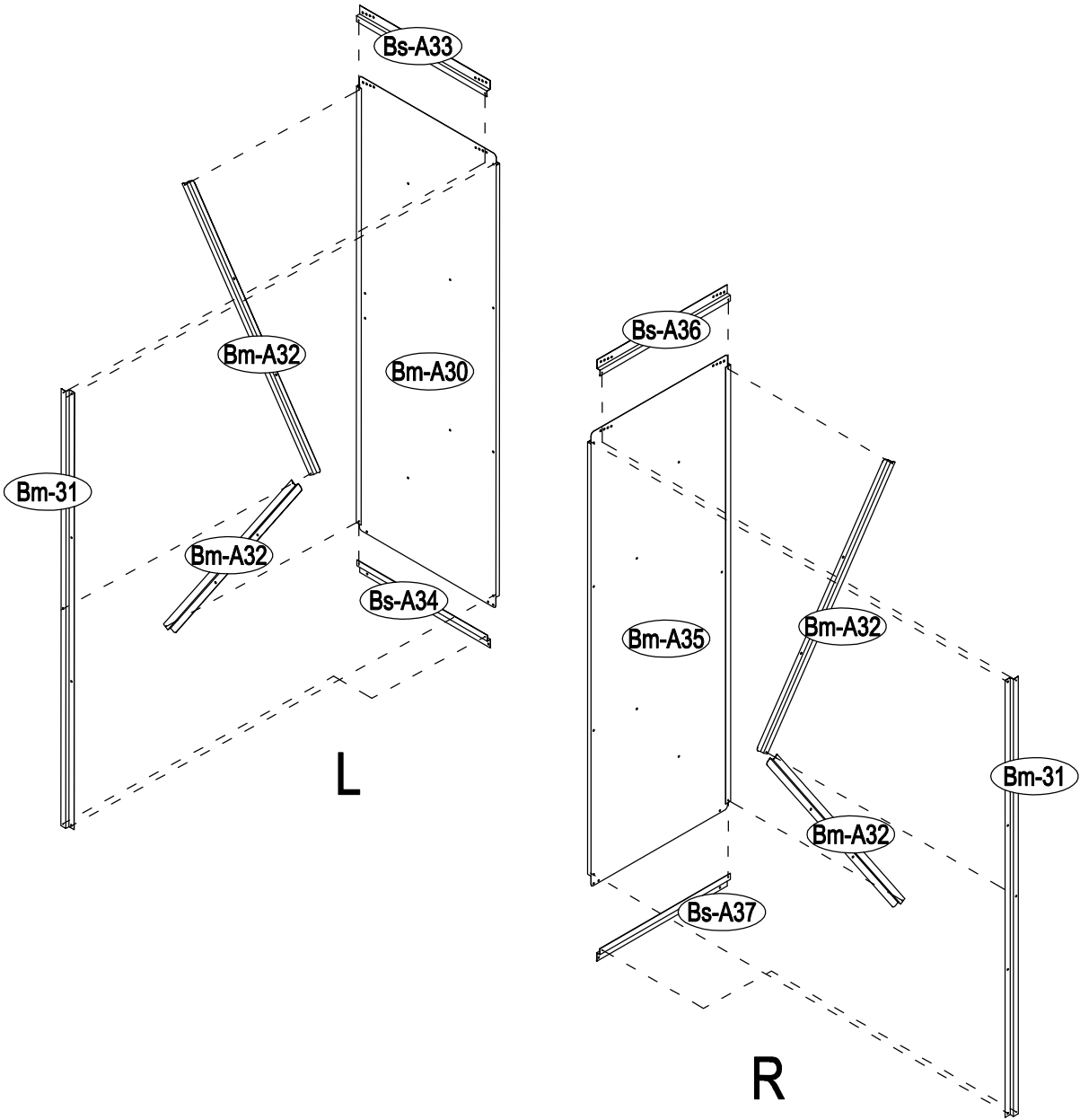

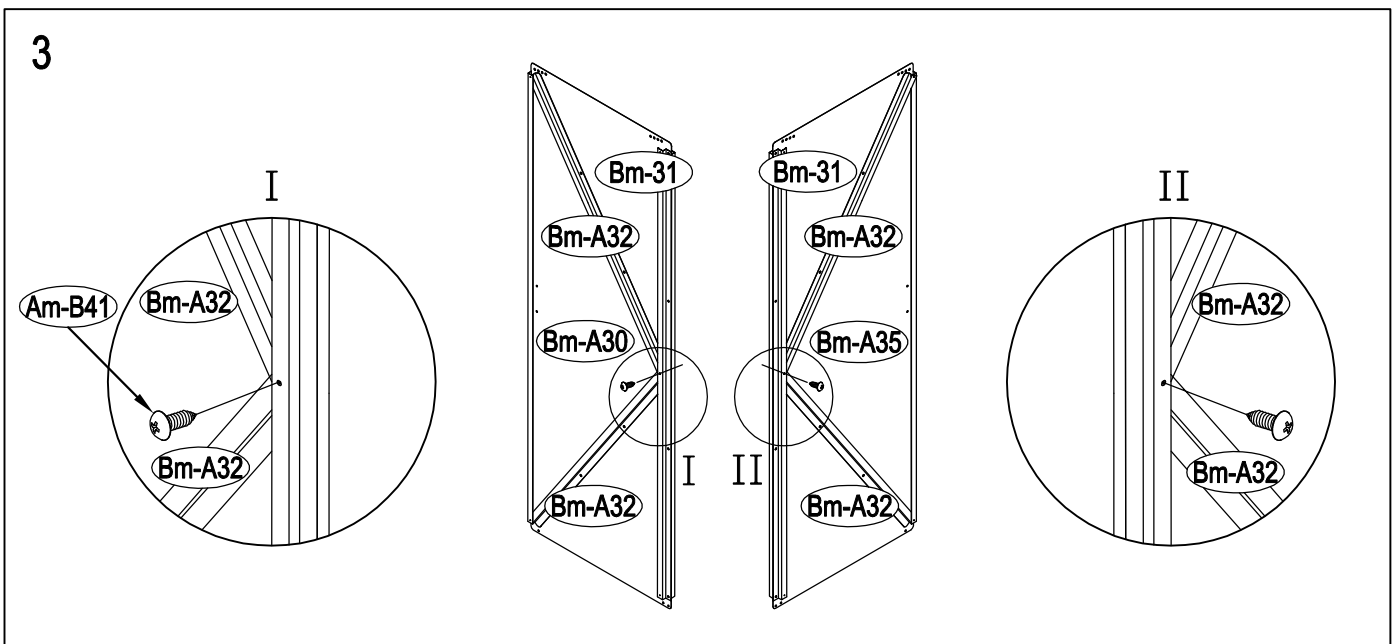
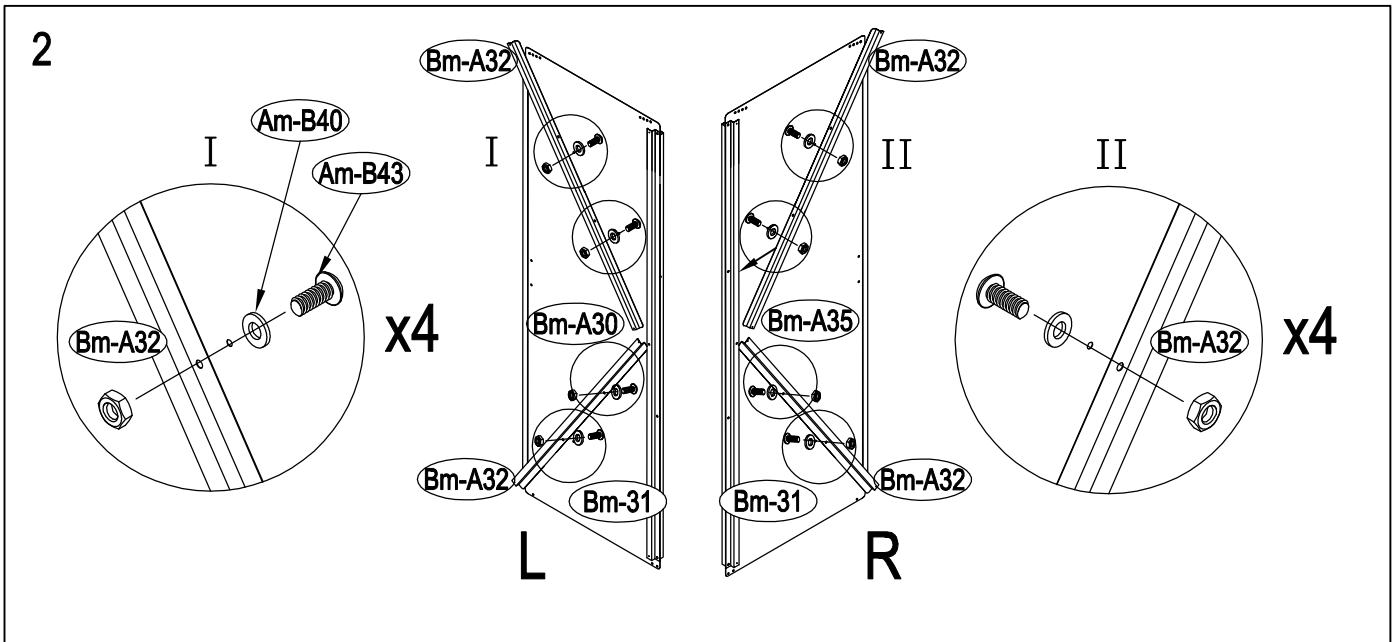
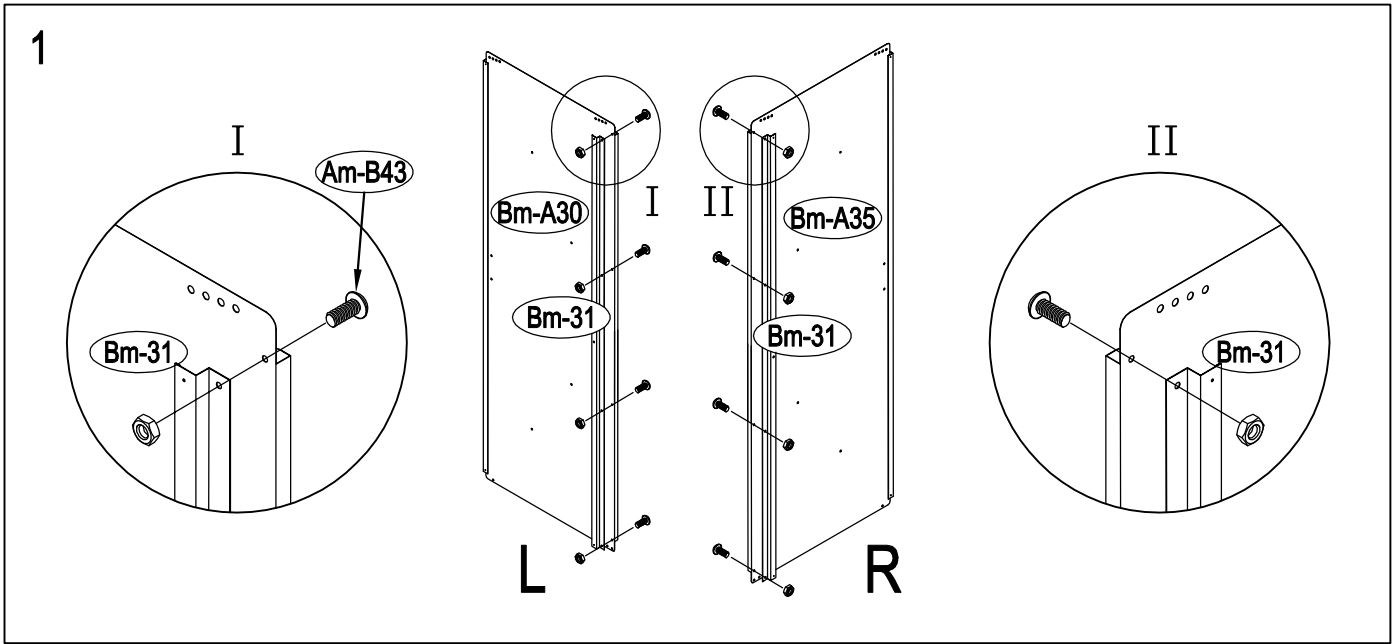

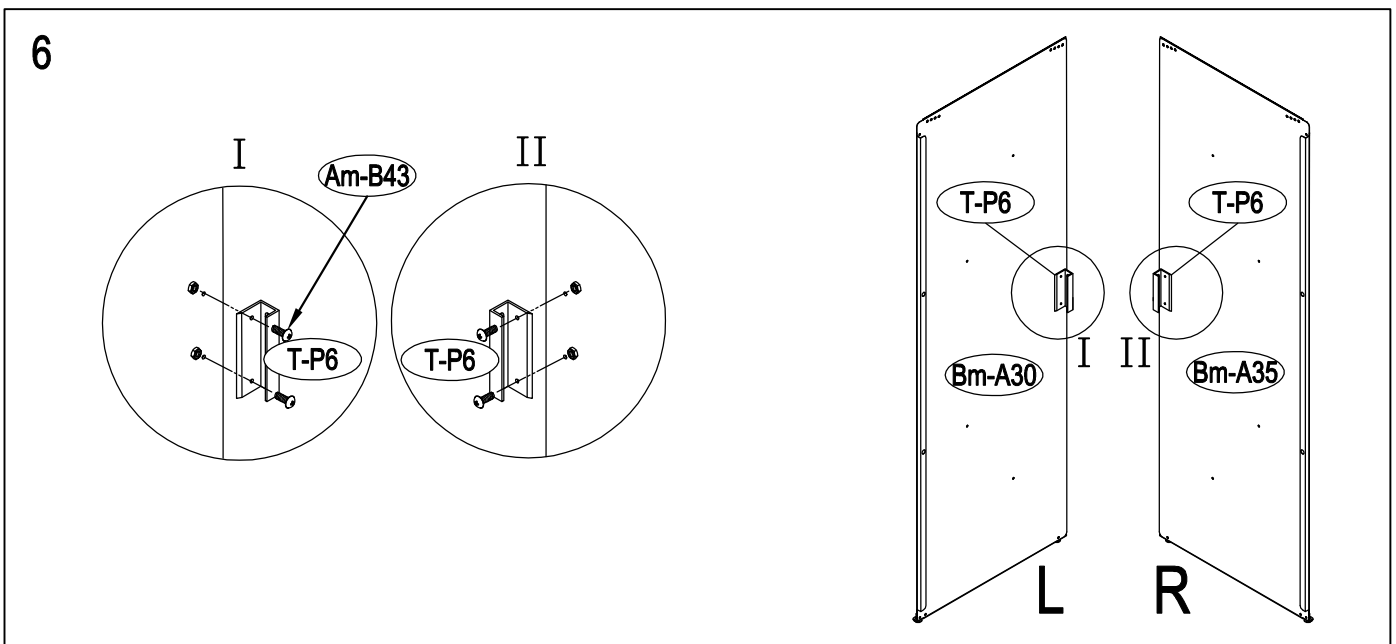
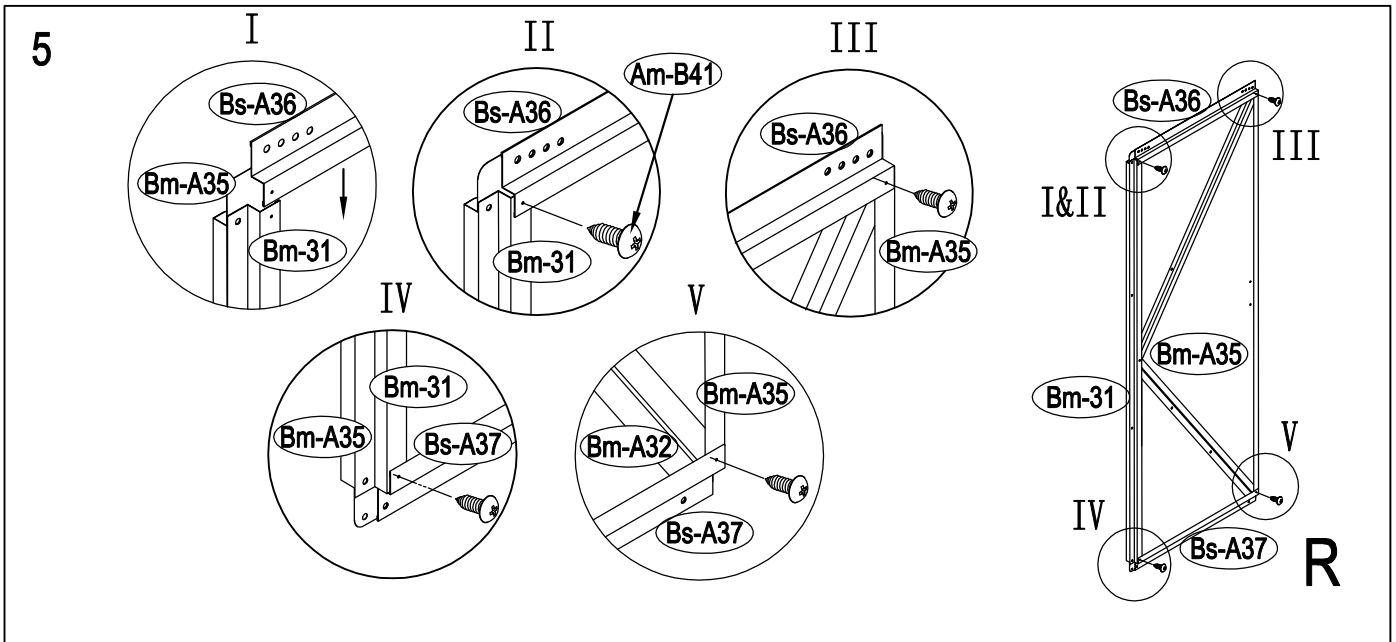
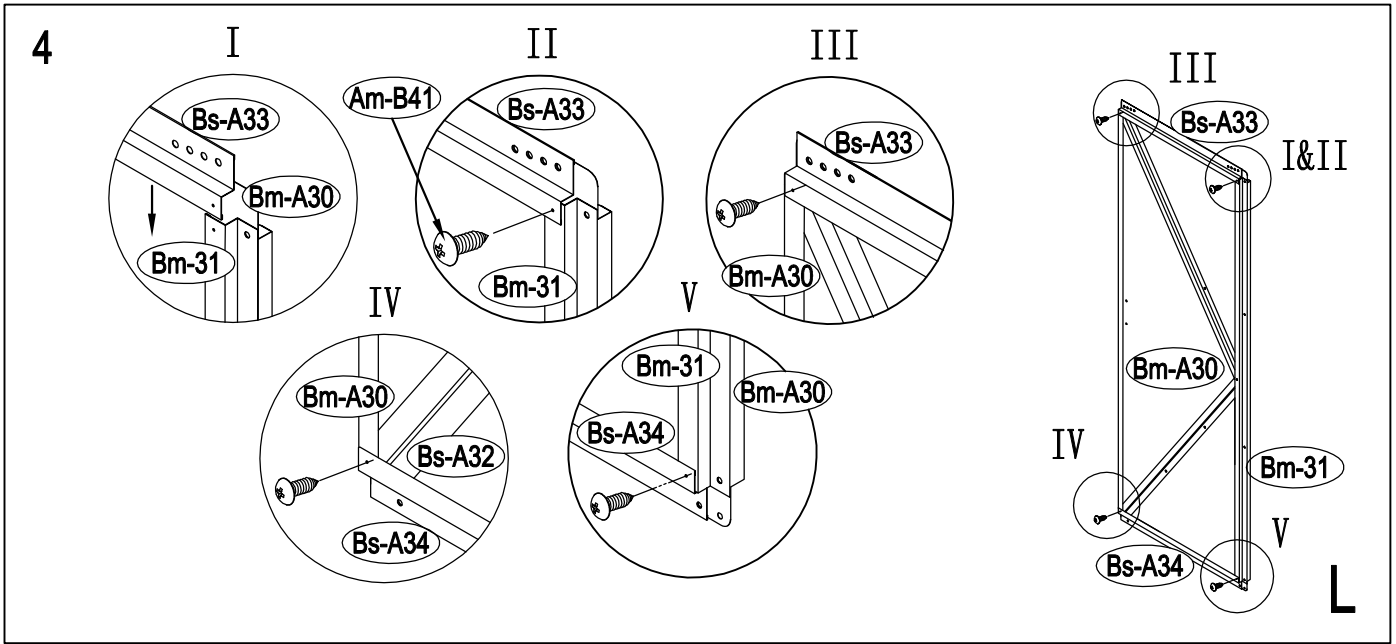

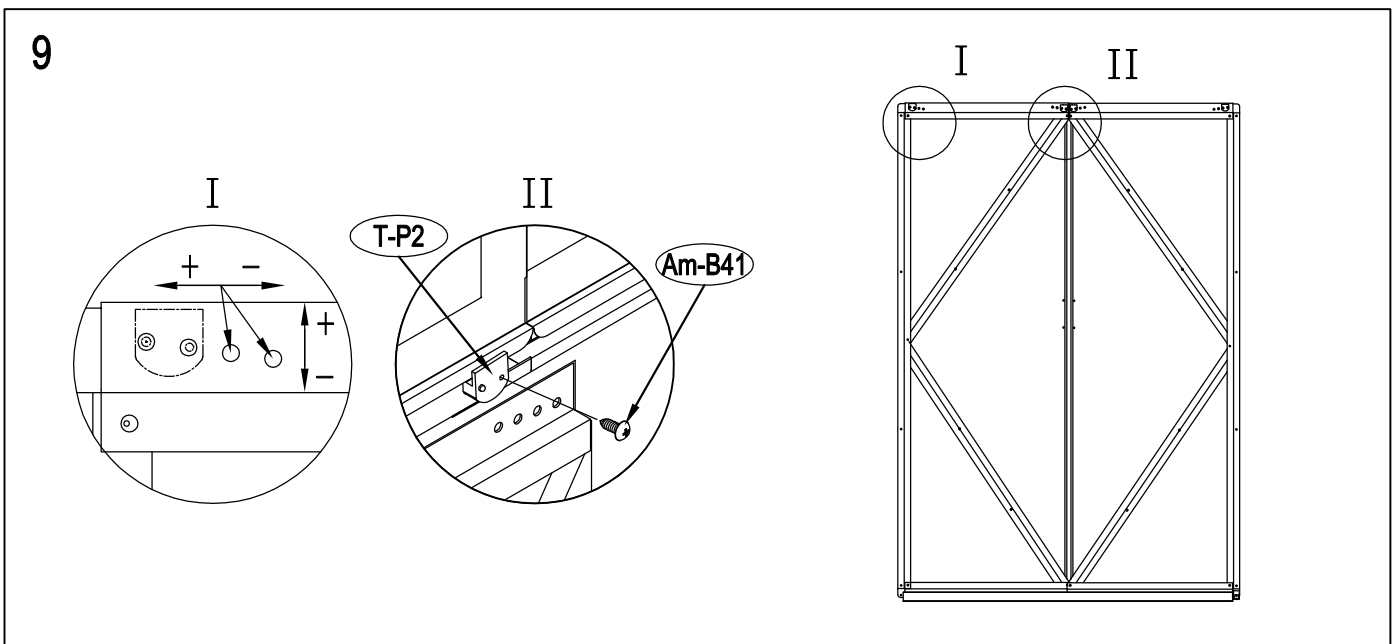
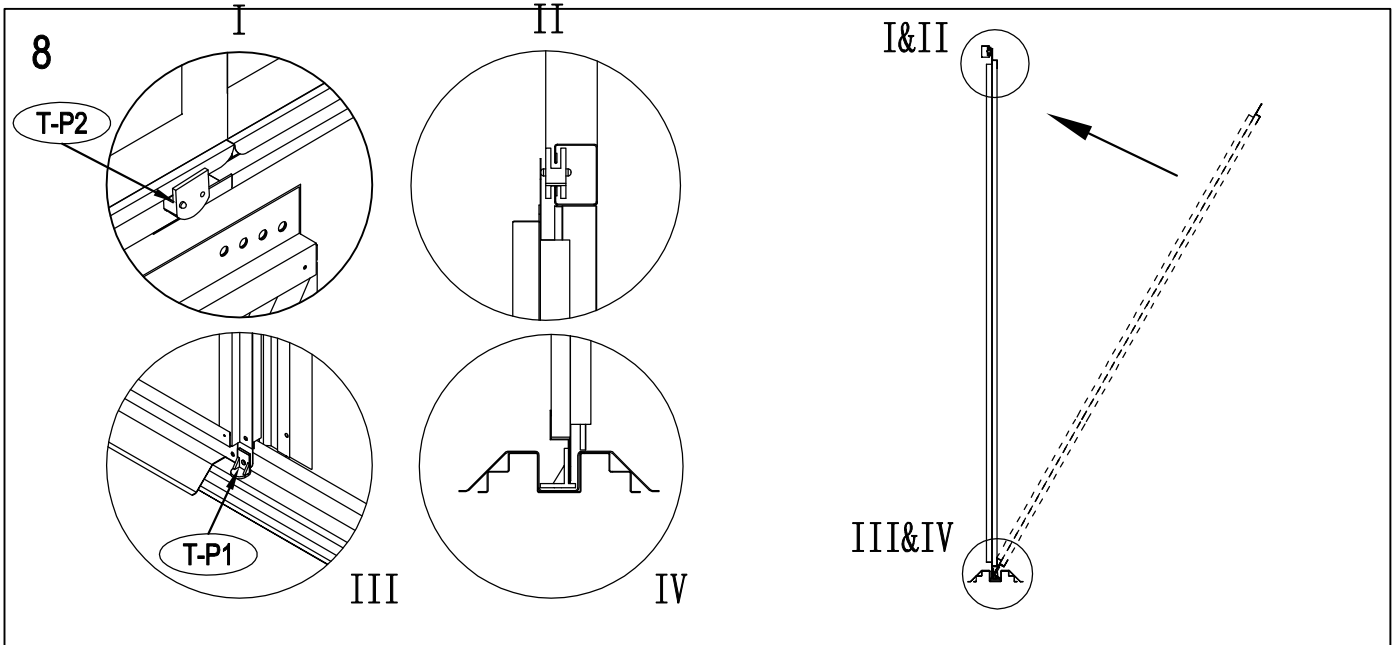
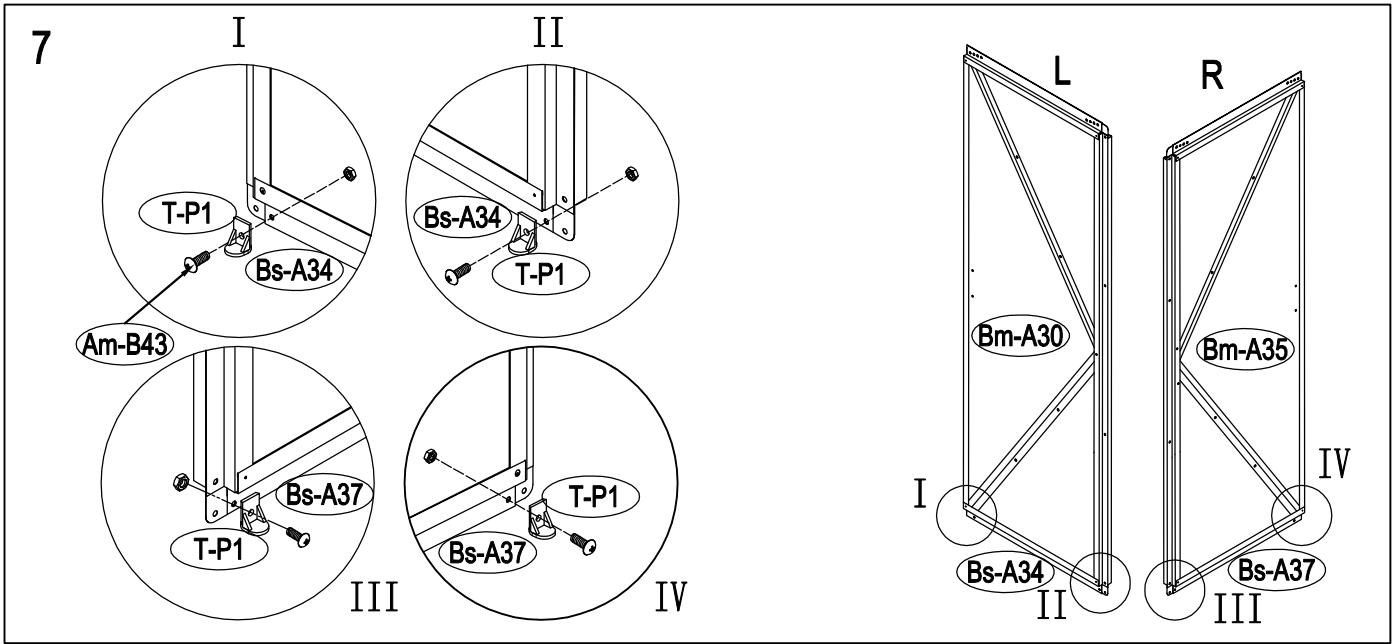

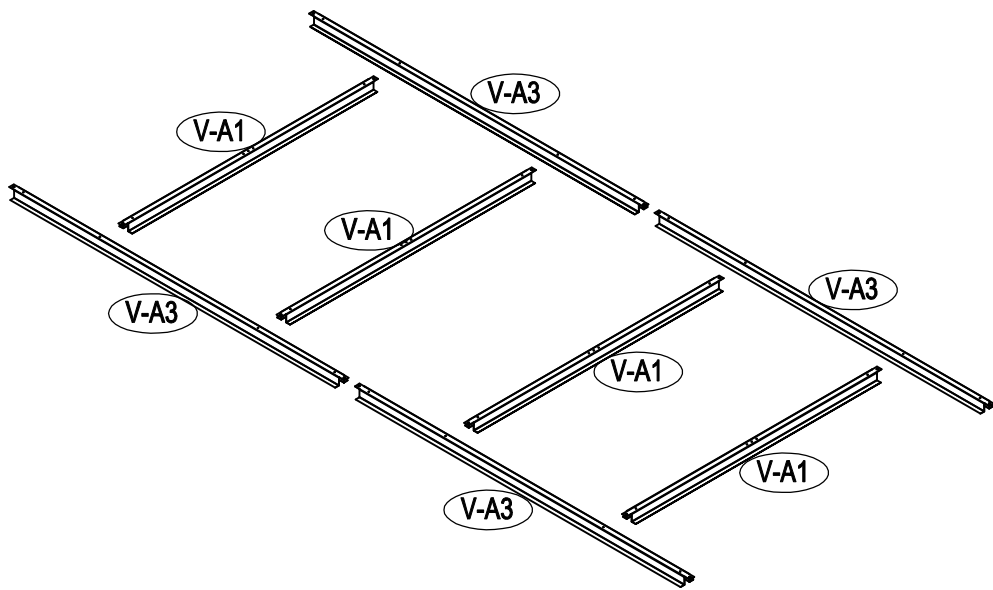

1

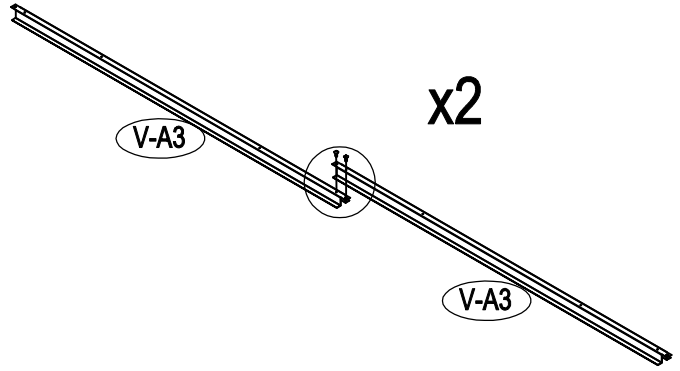
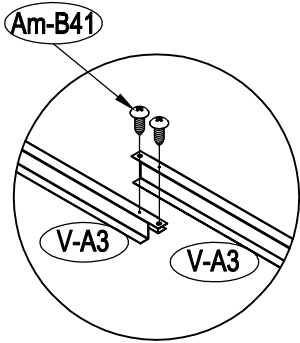

2

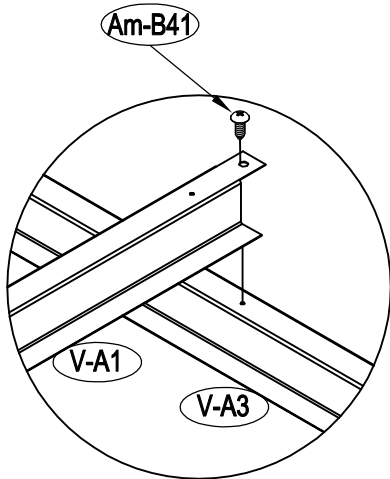

x8

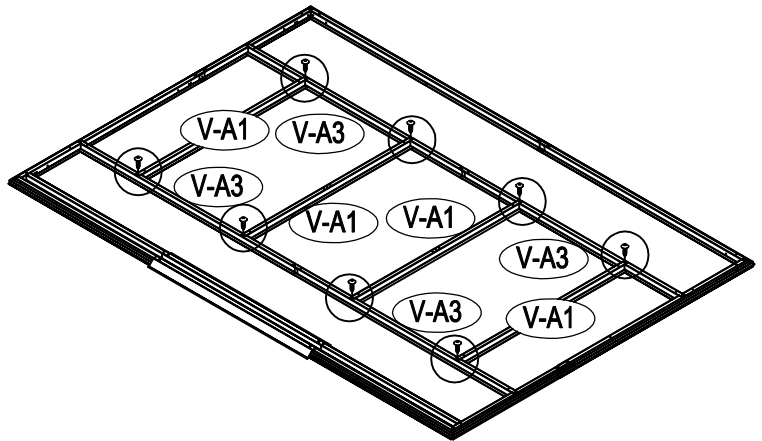

3

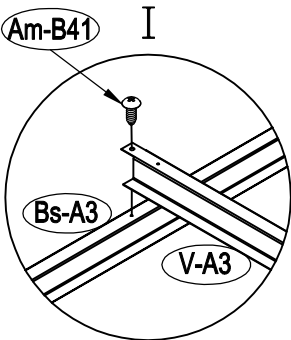

x2

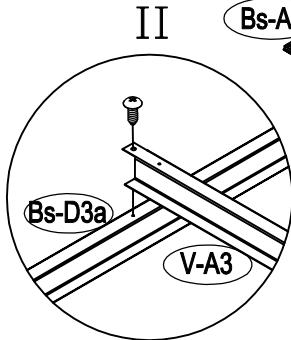

x2

