

# Installation Instruction

---

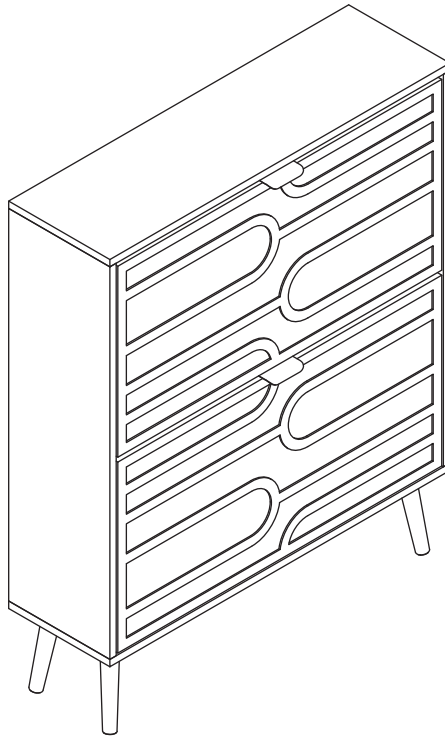

---

## EN

1. Place all parts on a clean, flat, and soft surface (e.g., carpet or rug) to prevent scratches.
2. DO NOT USE POWER TOOLS FOR ASSEMBLY.
3. Do not sit, stand, or allow children to climb, sit, or stand on the assembled product.
4. KEEP ALL HARDWARE PARTS OUT OF CHILDREN'S REACH.
5. DISPOSE OF PLASTIC PACKAGING IMMEDIATELY TO PREVENT SUFFOCATION RISKS TO CHILDREN OR PETS.
6. For safety reasons, this unit must be securely mounted to the wall.
7. Assembly requires two people.

## DE

1. Legen Sie alle Teile auf eine saubere, flache und weiche Oberfläche (z. B. Teppich oder Matte), um Kratzer zu vermeiden.
2. VERWENDEN SIE KEINE ELEKTROWERKZEUGE FÜR DEN ZUSAMMENBAU.
3. Setzen oder stellen Sie sich nicht auf das montierte Produkt, und lassen Sie Kinder nicht darauf klettern, sitzen oder stehen.
4. HALTE ALLE HARDWARETEILE AUSSERHALB DER REICHWEITE VON KINDERN.
5. ENTSORGEN SIE KUNSTSTOFFVERPACKUNGEN SOFORT, UM ERSTICKUNGSRISIKEN FÜR KINDER ODER HAUSTIERE ZU VERMEIDEN.
6. Aus Sicherheitsgründen muss diese Einheit sicher an der Wand befestigt werden.
7. Für den Zusammenbau werden zwei Personen benötigt.

## FR

1. Placez toutes les pièces sur une surface propre, plate et molle (par exemple, un tapis ou une moquette) pour éviter les rayures.
2. N'UTILISEZ PAS D'OUTILS ÉLECTRIQUES POUR LE MONTAGE.
3. Ne vous asseyez pas, ne vous tenez pas debout et ne laissez pas les enfants grimper, s'asseoir ou se tenir debout sur le produit assemblé.
4. GARDEZ TOUTES LES PIÈCES DE QUINCAILLERIE HORS DE PORTÉE DES ENFANTS.
5. ÉLIMINEZ IMMÉDIATEMENT LES EMBALLAGES PLASTIQUES POUR ÉVITER TOUT RISQUE D'ÉTOUFFEMENT POUR LES ENFANTS OU LES ANIMAUX DOMESTIQUES.
6. Pour des raisons de sécurité, cette unité doit être solidement fixée au mur.
7. Le montage nécessite deux personnes.

**IT**

1. Posizionare tutte le parti su una superficie pulita, piana e morbida (ad esempio, tappeto o moquette) per evitare graffi.
2. NON UTILIZZARE UTENSILI ELETTRICI PER IL MONTAGGIO.
3. Non sedersi, non stare in piedi e non permettere ai bambini di arrampicarsi, sedersi o stare in piedi sul prodotto assemblato.
4. TENERE TUTTE LE PARTI DI FERRAMENTA FUORI DALLA PORTATA DEI BAMBINI.
5. SMALTIRE IMMEDIATAMENTE GLI IMBALLAGGI DI PLASTICA PER EVITARE QUALSIASI RISCHIO DI SOFFOCAMENTO PER BAMBINI O ANIMALI DOMESTICI.
6. Per motivi di sicurezza, è imperativo che questa unità sia fissata al muro.
7. Per il montaggio sono necessarie due persone.

**ES**

1. Coloque todas las partes sobre una superficie limpia, plana y suave (por ejemplo, alfombra o tapete) para evitar rayaduras.
2. NO UTILICE HERRAMIENTAS ELÉCTRICAS PARA EL ENSAMBLAJE.
3. No se siente, no se pare ni permita que los niños se suban, se sienten o se paren sobre el producto ensamblado.
4. MANTENGA TODAS LAS PIEZAS DE HERRAMIENTA FUERA DEL ALCANCE DE LOS NIÑOS.
5. DESECHE INMEDIATAMENTE LOS ENVASES DE PLÁSTICO PARA EVITAR CUALQUIER RIESGO DE ASFIXIA PARA NIÑOS O MASCOTAS.
6. Por razones de seguridad, es imprescindible que esta unidad esté fijada a la pared.
7. Se necesitan dos personas para el ensamblaje.

**WARNING!!**

**Children have died from furniture tipover. Tip restraints have been included with this product; you must install the tip restraints according to these instructions in order to minimize the risk of furniture tipping.**

- In addition to installing the restrains , to help prevent tip-over**
1. **NEVER** put a TV or other heavy objects on top of this product".
  2. **Do not stand on the product.**

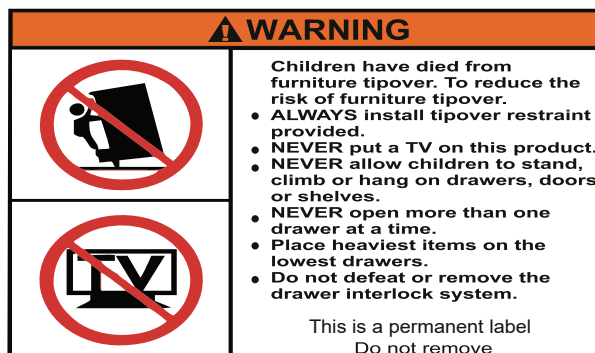
**MADE IN CHINA****UK  
CA**



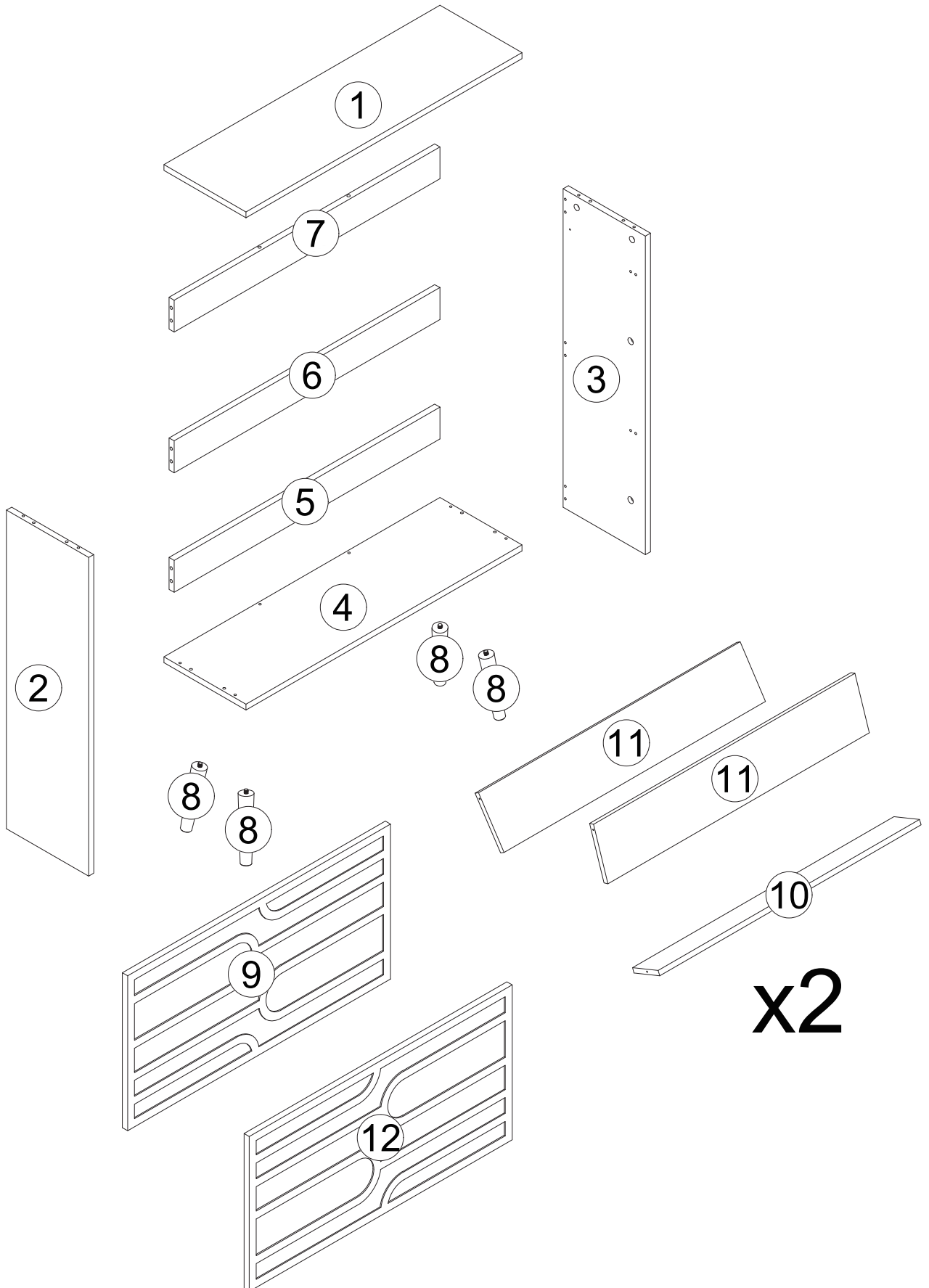



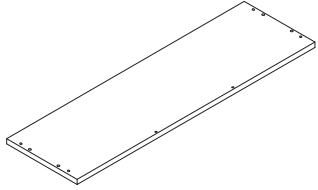
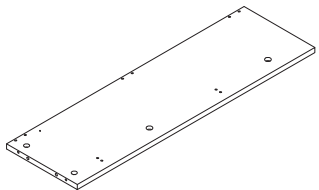
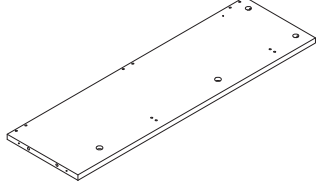
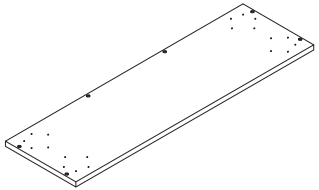
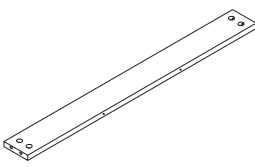
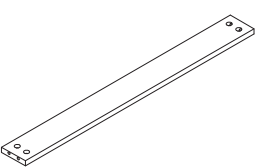
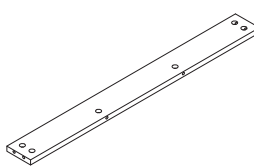
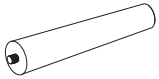
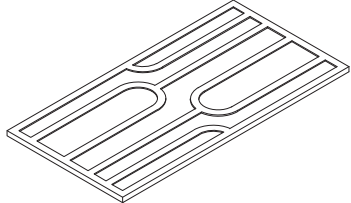
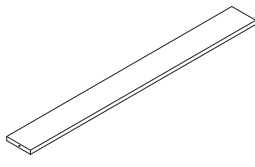
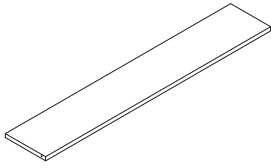
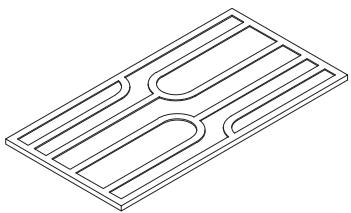



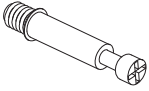

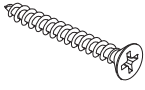

# Parts

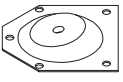
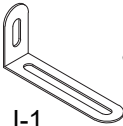

# Installation Parts

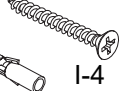
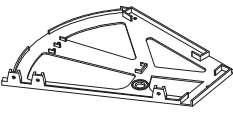
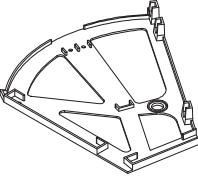
<p>① 1PC</p> 	<p>② 1PC</p> 	<p>③ 1PC</p> 
<p>④ 1PC</p> 	<p>⑤ 1PC</p> 	<p>⑥ 1PC</p> 
<p>⑦ 1PC</p> 	<p>⑧ 4PC</p> 	<p>⑨ 1PC</p> 
<p>⑩ 2PC</p> 	<p>⑪ 4PC</p> 	<p>⑫ 1PC</p> 

# Sheet Parts

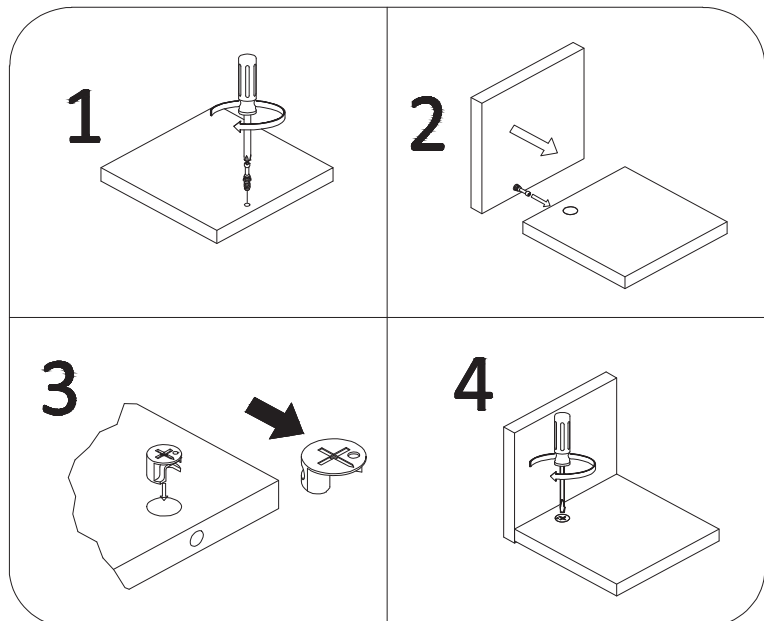
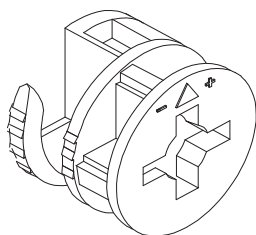
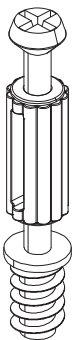

<p><b>A</b> M6*35</p>  <p>18 PCS +2(spare)</p>	<p><b>B</b> M15*10</p>  <p>18 PCS +2(spare)</p>	<p><b>C</b> Ø6*30</p>  <p>8 PCS +1(spare)</p>	<p><b>D</b> M4*35</p>  <p>6PCS +1(spare)</p>
<p><b>E</b> M3.5*12</p>  <p>24 PCS +3(spare)</p>	<p><b>F</b></p>    <p>F-1 F-2 F-3 4PCS</p>	<p><b>G</b></p>  <p>4PCS +1(spare)</p>	<p><b>H</b></p>  <p>4PCS</p>
<p><b>I</b></p>     <p>I-1 I-2 I-3 I-4 2PCS</p>	<p><b>J</b></p>  <p>2PCS</p>	<p><b>K</b></p>  <p>2PCS</p>	<p><b>L</b> M4*12</p>  <p>20PCS +2(spare)</p>
<p><b>M</b></p>  <p>4PCS +1(spare)</p>	<p><b>N</b></p>   <p>N-1 N-2 2PCS</p>		

This Cam Lock Fastening System will be used throughout the assembly process



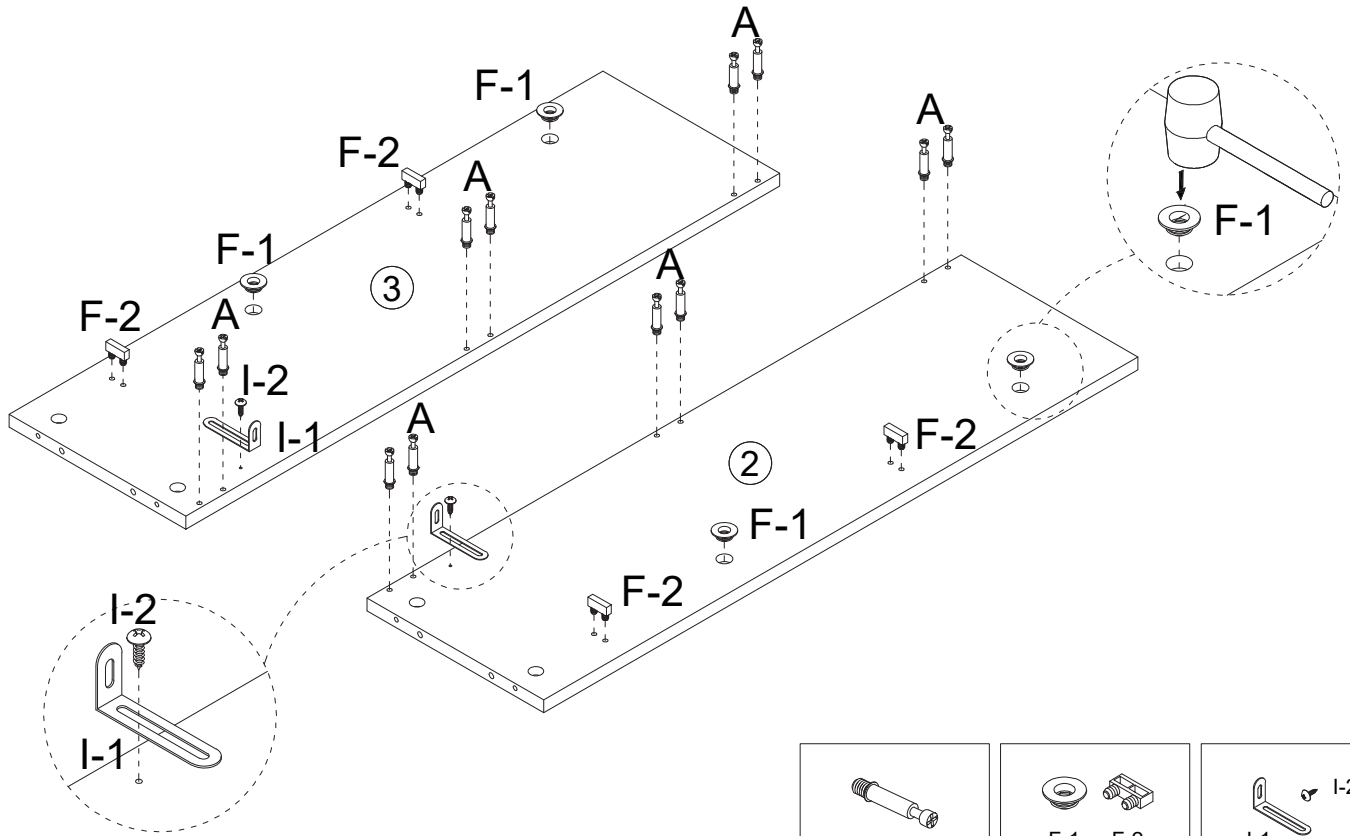

# STEP 1

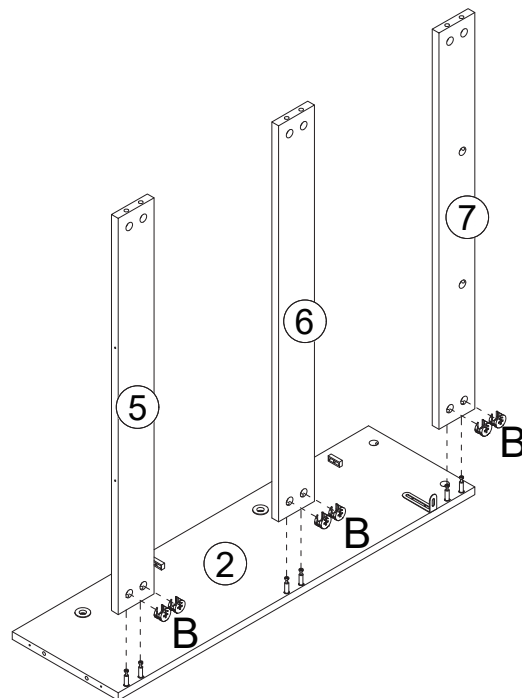

		
A	F-1 F-2	I-1 I-2
x12	x4	x2

# STEP 2



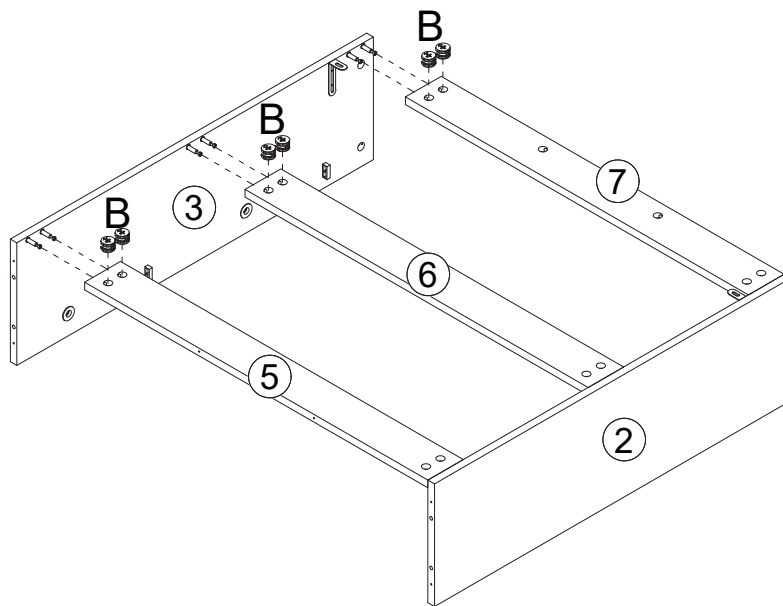

B
x6

# STEP 3

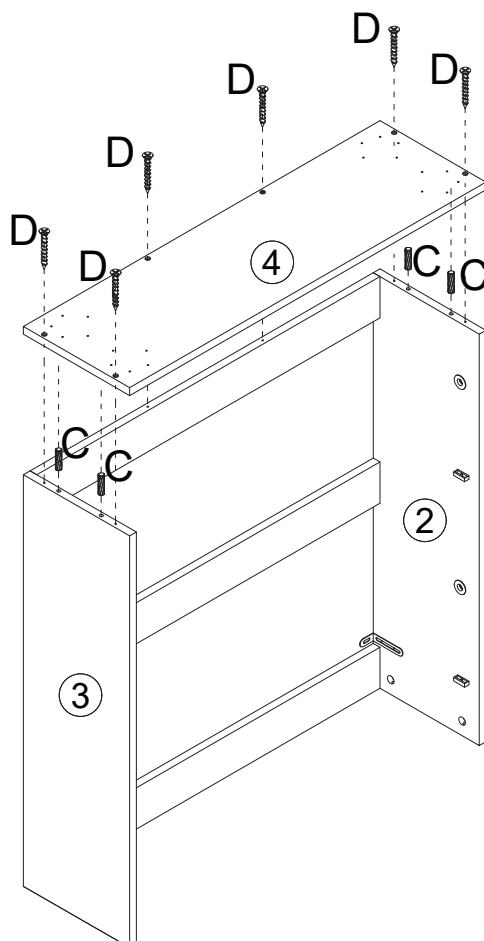

B x6

# STEP 4





C x4

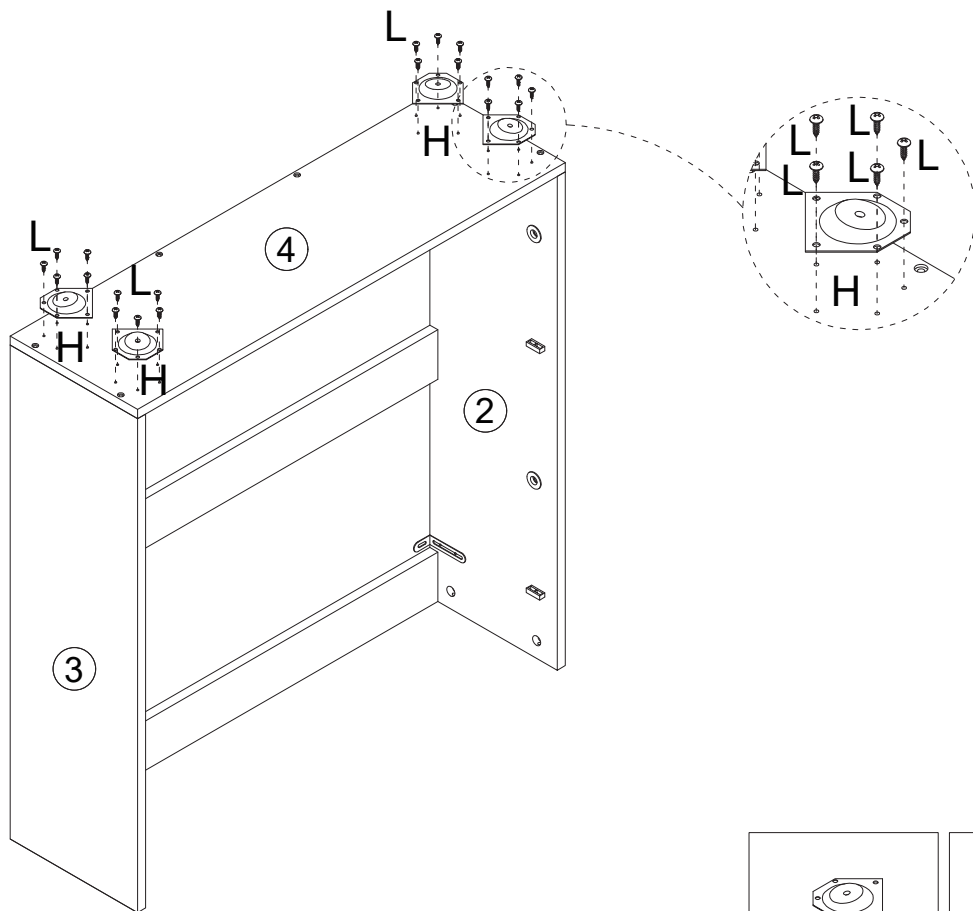

D x6

# STEP 5



	
H x4	L x20

# STEP 6

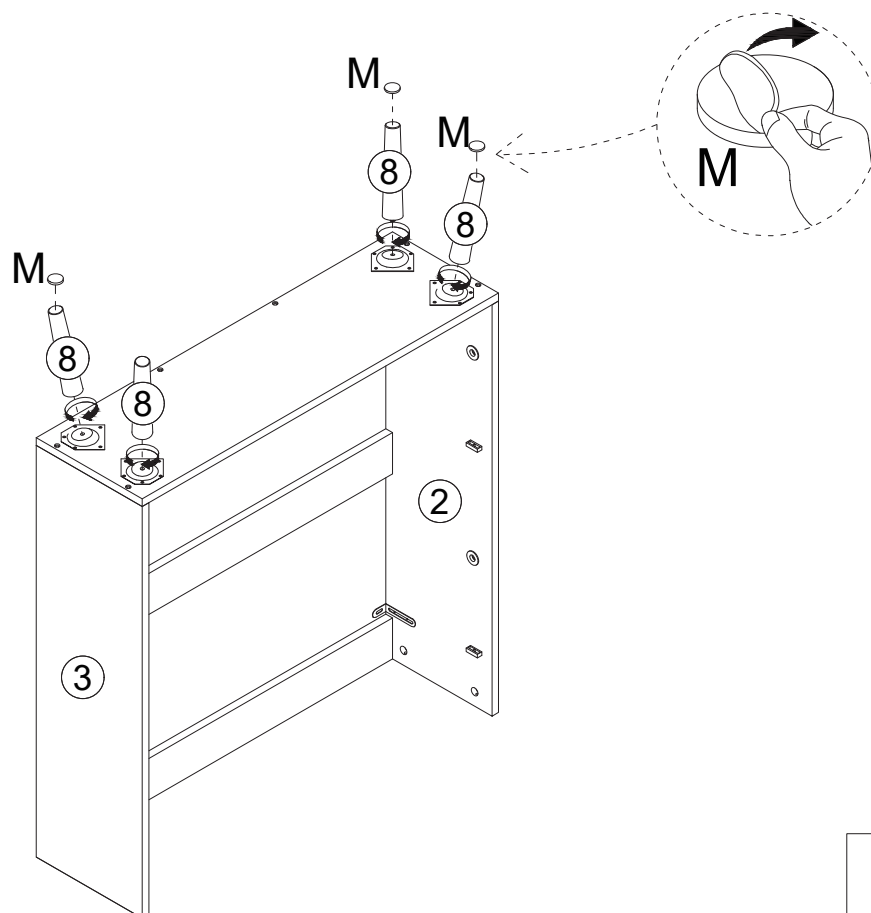

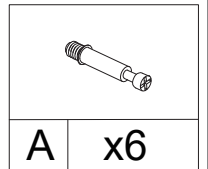
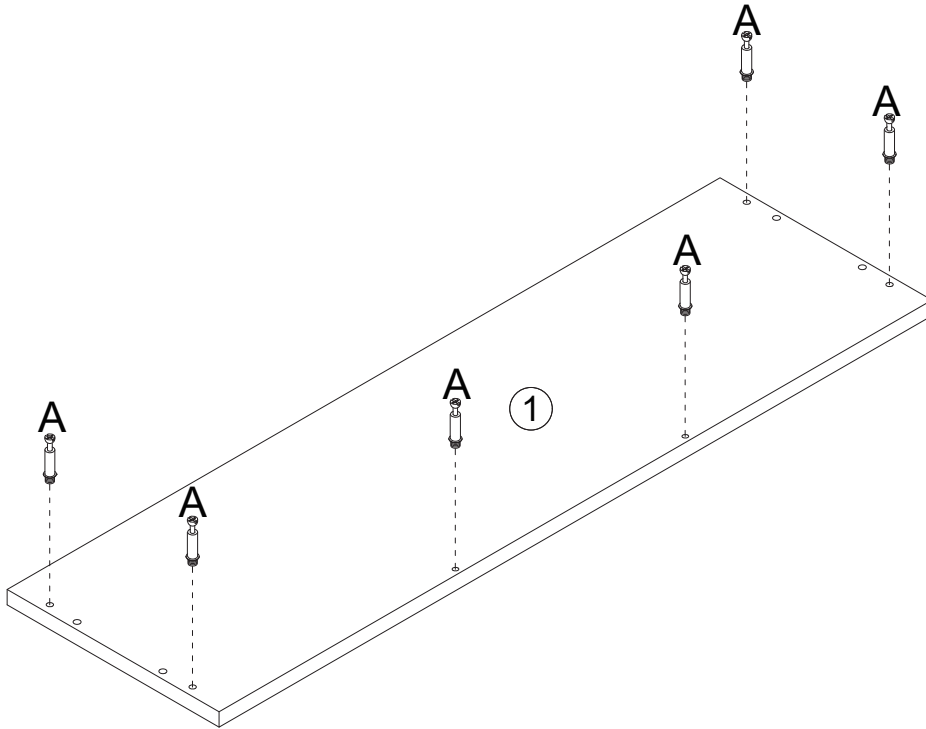

M x4

# STEP 7

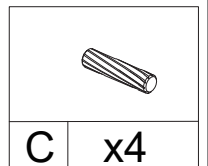
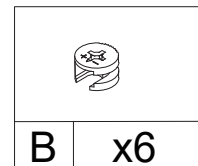
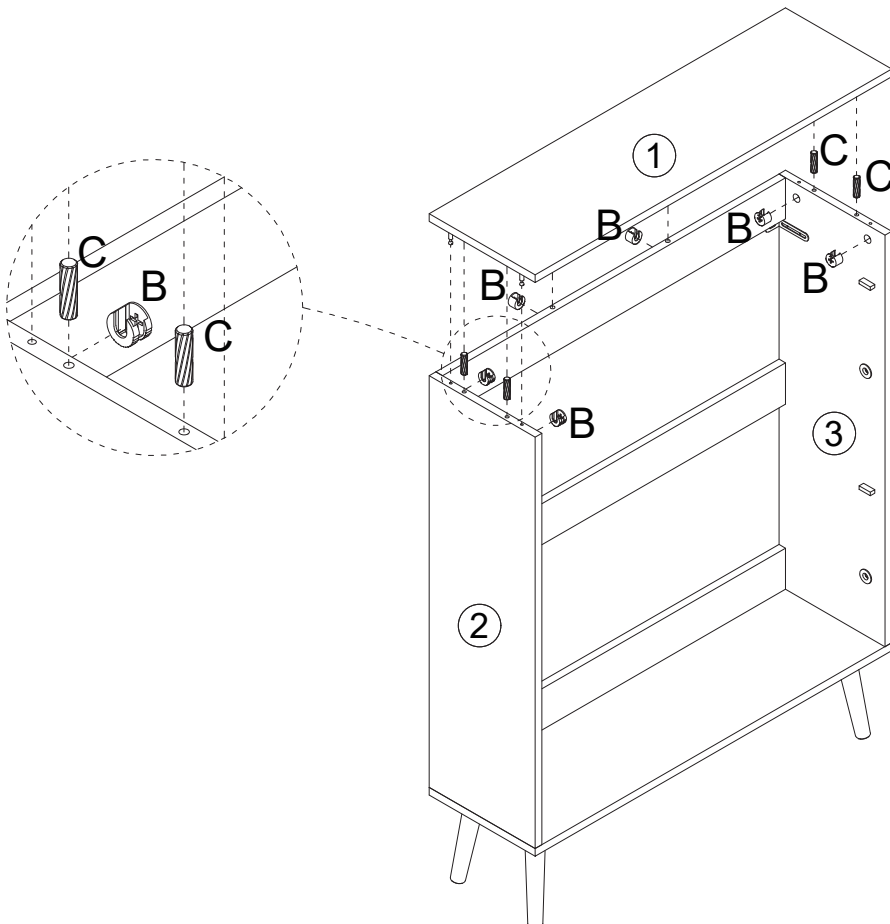

# STEP 8





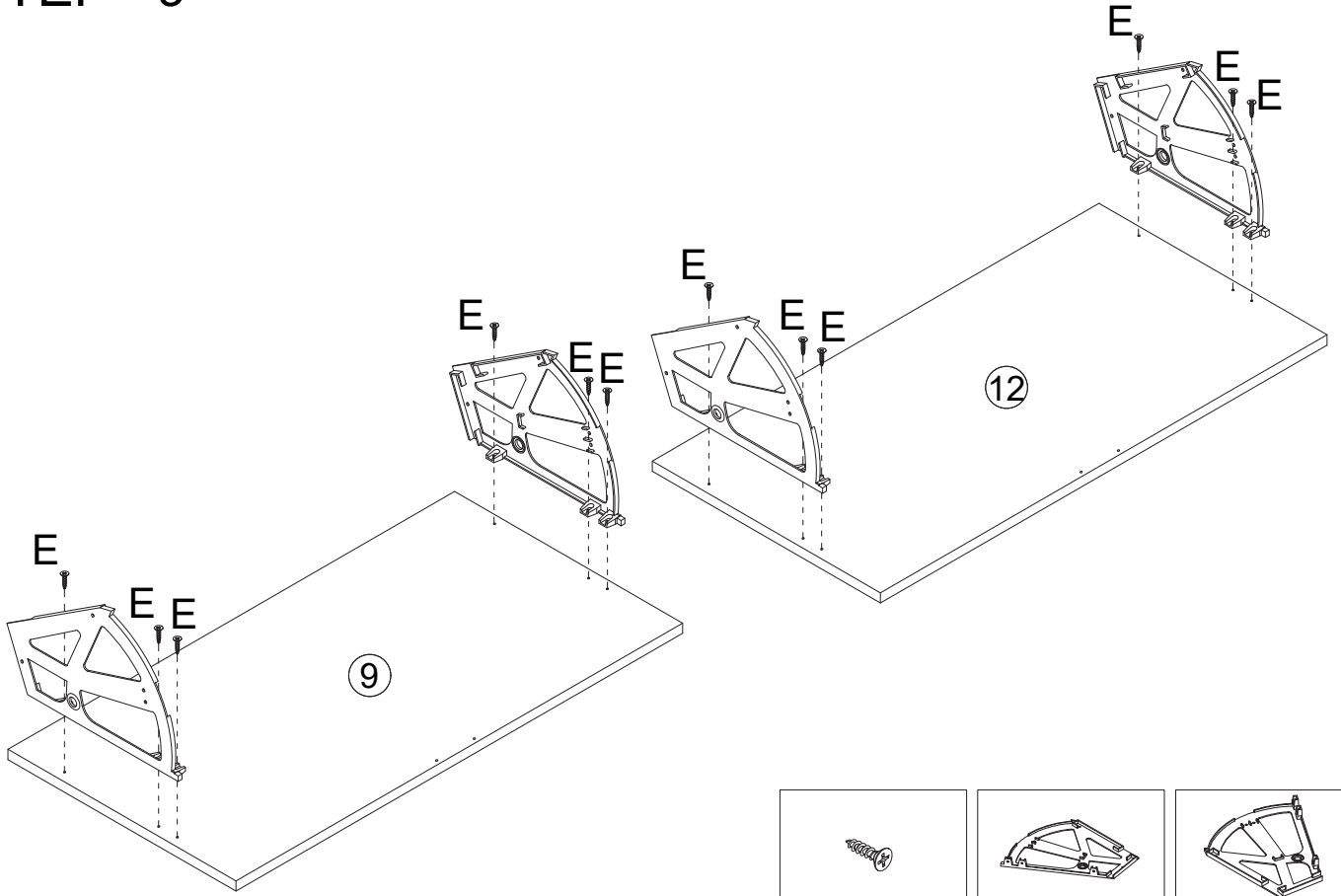

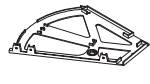
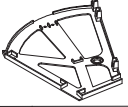
# STEP 9

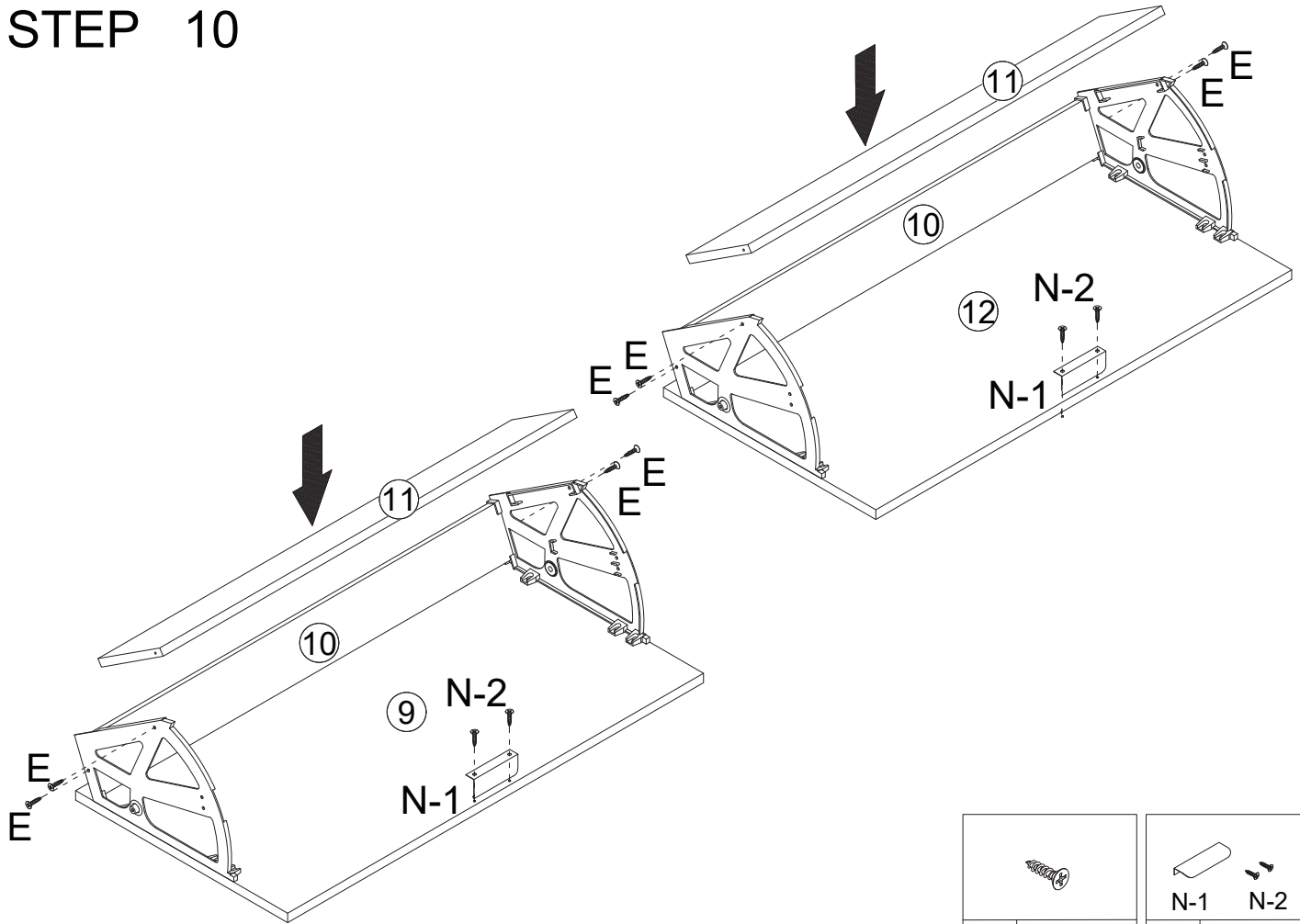

		
E	J	K
x12	x2	x2



# STEP 10

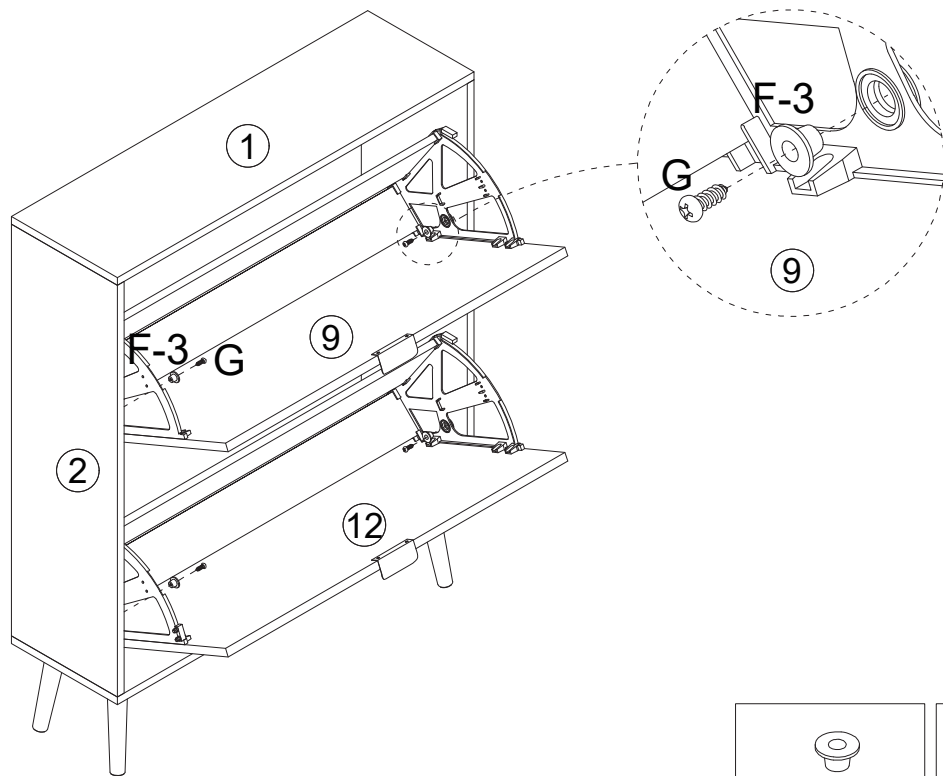

		
E	N-1	N-2
x8	K	x2

# STEP 11



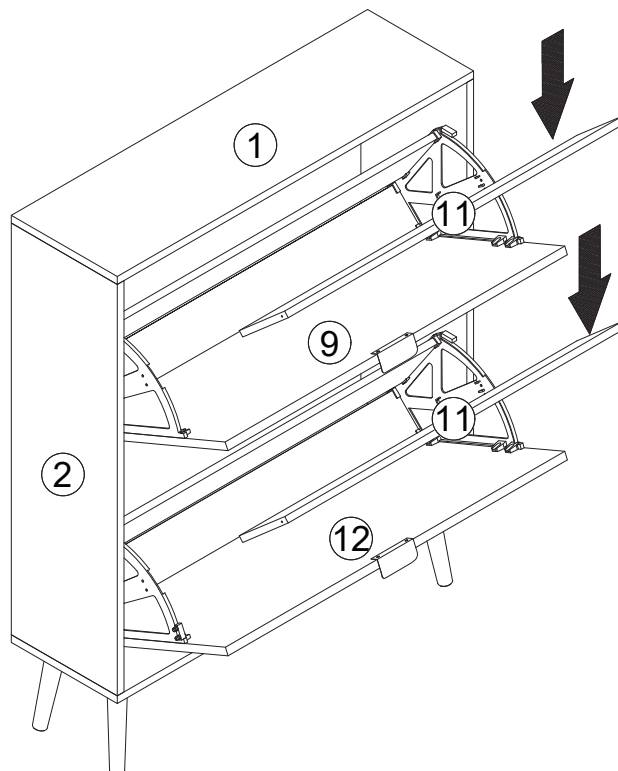

	
F-3	
F x4	G x4

# STEP 12

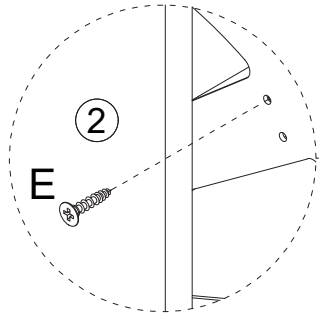
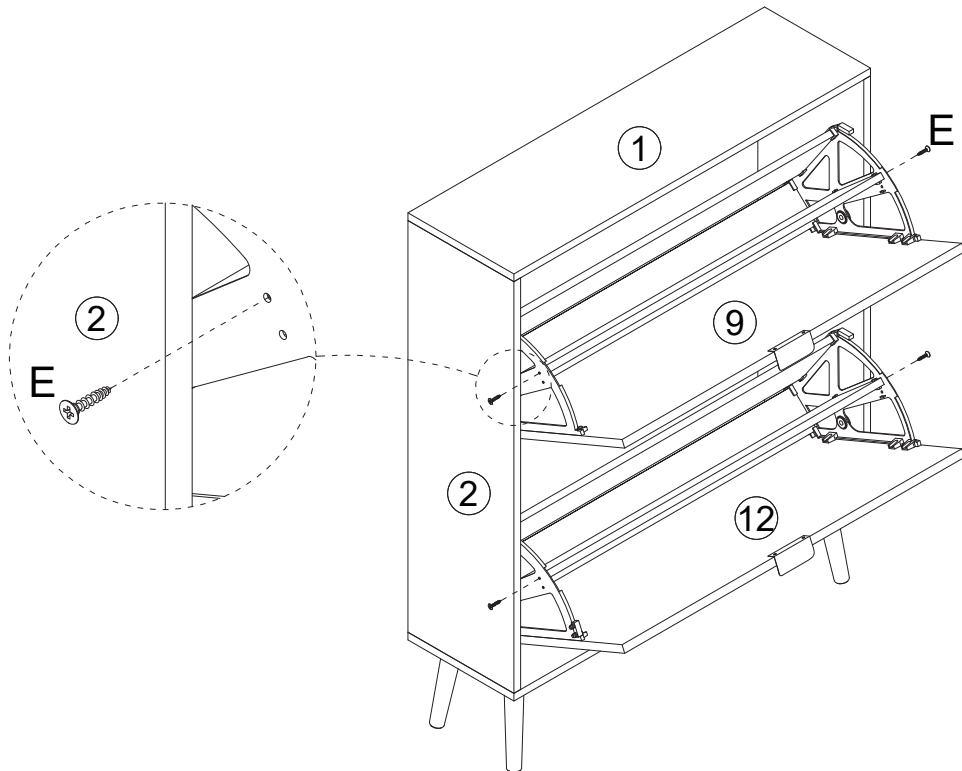

# STEP 13



	
E	x4

# STEP 14

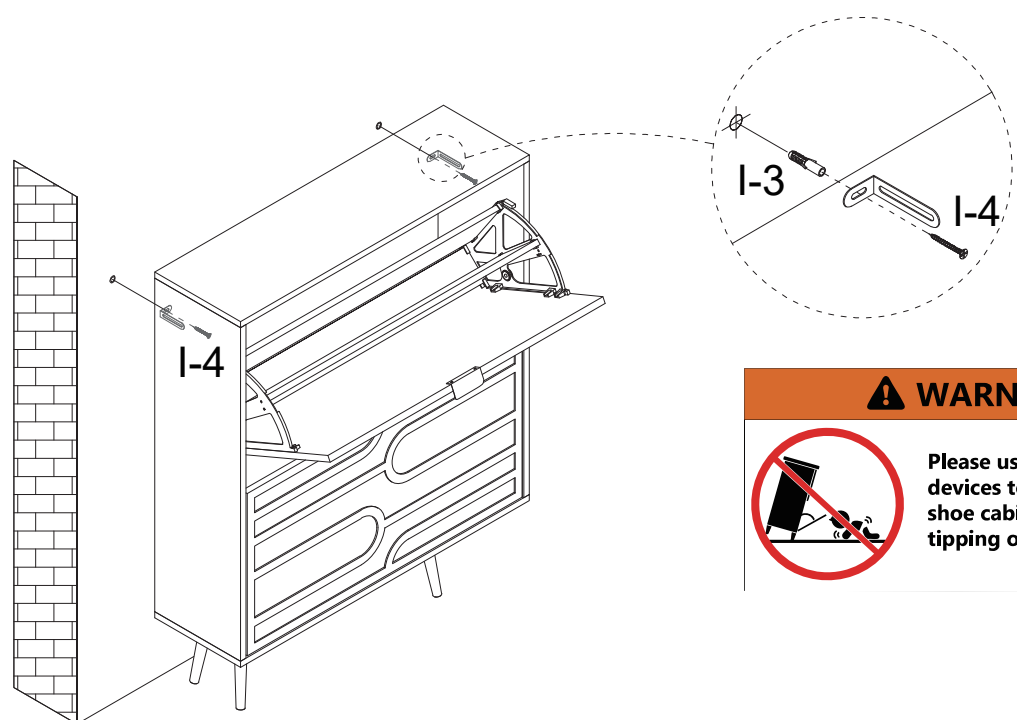
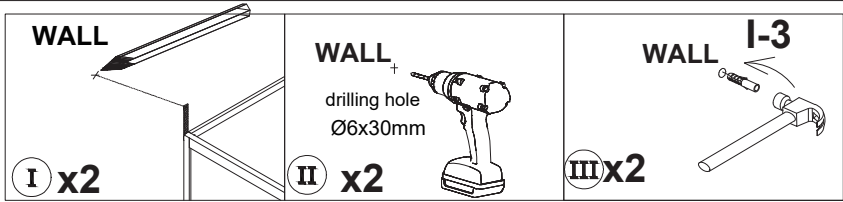

**⚠ WARNING**

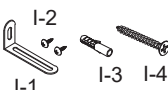

Please use anti tipping devices to prevent the shoe cabinet from tipping over.

	
I	x2