

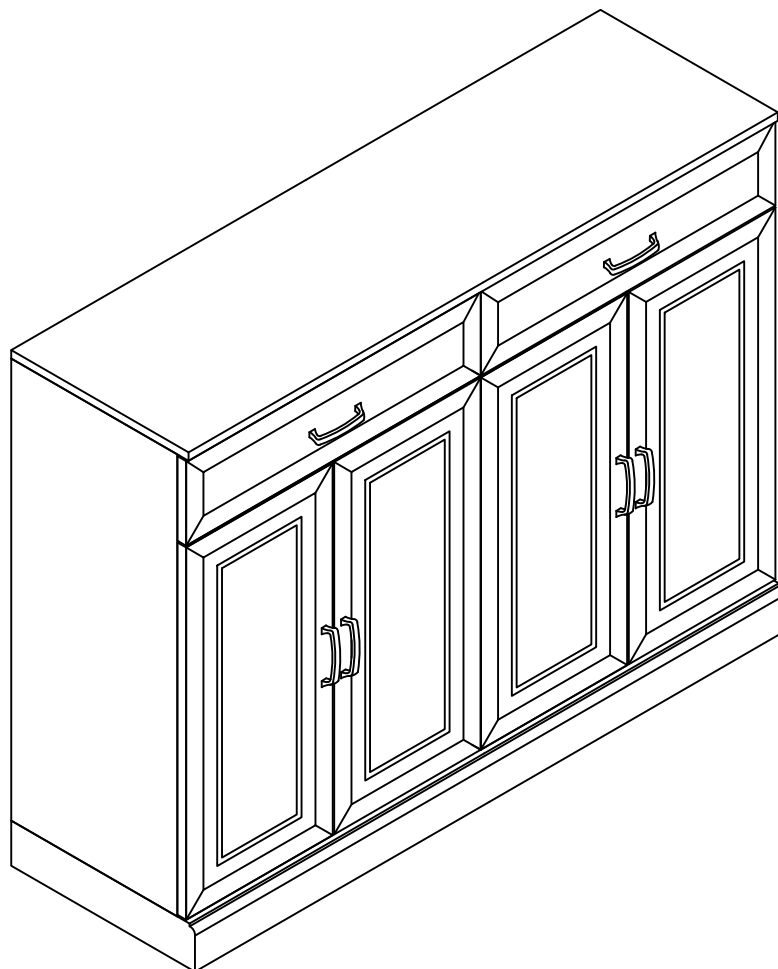



CROSLEY
FURNITURE

Sideboard



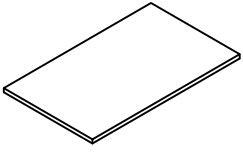
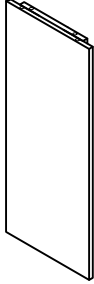
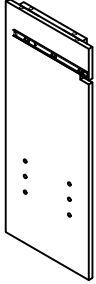
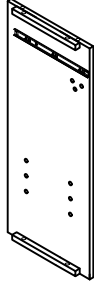
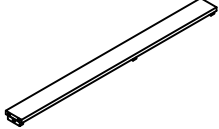
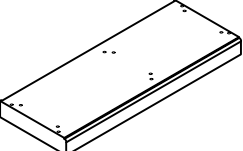
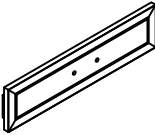
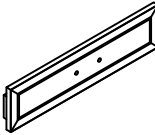



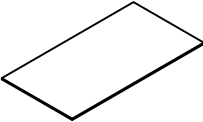
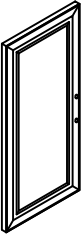
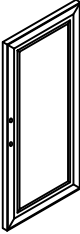
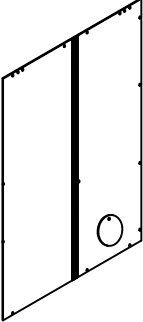
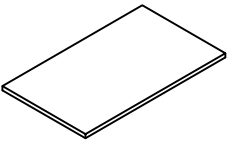
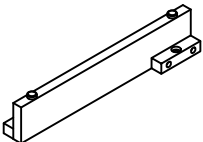
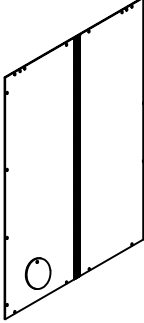
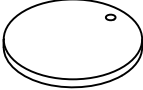



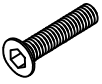

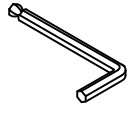
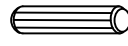
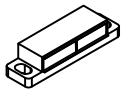

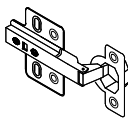
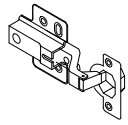
CF4213

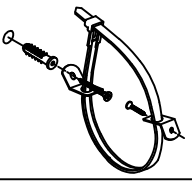

PART LIST

<p>A</p> 	<p>B</p> 	<p>C2</p> 	<p>D</p> 	<p>E</p> 
<p>Top Panel 1 PC</p>	<p>Left Panel 1 PC</p>	<p>Partition Panel 1 PC</p>	<p>Right Panel 1 PC</p>	<p>Cross Rail 1 PC</p>
<p>F</p> 	<p>G</p> 	<p>H</p> 	<p>I2</p> 	<p>J2</p> 
<p>Bottom Panel 1 PC</p>	<p>Drawer Left Front Panel 1 PC</p>	<p>Drawer Right Front Panel 1 PC</p>	<p>Drawer Left Panel 2 PCS</p>	<p>Drawer Right Panel 2 PCS</p>
<p>K2</p> 	<p>L2</p> 	<p>M</p> 	<p>N</p> 	<p>O2</p> 
<p>Drawer Back Panel 2 PCS</p>	<p>Drawer Bottom Panel 2 PCS</p>	<p>Left Door Panel 2 PCS</p>	<p>Right Door Panel 2 PCS</p>	<p>Right Back Panel 1 PC</p>
<p>P2</p> 	<p>Q</p> 	<p>R2</p> 	<p>S2</p> 	
<p>Adjustable Shelf 2 PCS</p>	<p>Support Rail 1 PC</p>	<p>Left Back Panel 1 PC</p>	<p>Cover 2 PCS</p>	

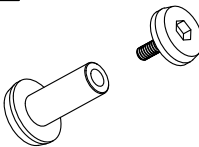
HARDWARE LIST

#1  Ø1/4"*25mm Bolt 17 PCS (Extra 1)	#2  Ø1/4"*11mm Spring Washer 17 PCS (Extra 1)	#3  Ø1/4"*13mm Flat Washer 17 PCS (Extra 1)	#4  4mm*90 Allen Wrench 1 PC	#5  Ø8*30mm Wood Dowel 18 PCS (Extra 1)
#6  Double Magnet 2 PCS	#7  6*3*15mm Round Head Screw 4 PCS (Extra 1)	#8  Straight Door Hinge 4 PCS	#9  Spring Door Hinge 4 PCS	#10  7*3.5*15mm Screw 48 PCS (Extra 1)
#11  Handle 6 PCS	#12  5/32"*19mm Long Round Head Bolt 8 PCS (Extra 1)	#13  5/32"*15mm Short Round Head Bolt 4 PCS (Extra 1)	#14  Shelf Holder 8 PCS (Extra 1)	#15  8*3*12mm Short Screw 26 PCS (Extra 1)
#16  Safety Strap Kit 1 SET	#17  8*4*25 Long Screw 16 PCS (Extra 1)	#18  Binding Post 2 SETS	#19  M2 Small Allen Wrench 1 PC	

ADDITIONAL TOOLS (Not Provided)

Note: It is not recommended to use power tools during assembly.

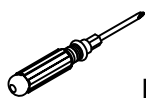

Phillips Head Screwdriver

Note: Wood dowels are intended for alignment. Additional clearance between wood dowel and pre-drilled hole is intentional for ease of assembly.

Step 1. Attach support rail (part Q) to bottom panel (part F) using wood dowels (part #5), bolt (part #1), spring washer (part #2), flat washer (part #3) and allen wrench (part #4).

Attach double magnets (part #6) to cross rail (part E) using round head screws (part #7) and phillips head screwdriver.

Attach handles (part #11) to drawer left front panel (part G) and drawer right front panel (part H) using short round head bolts (part #13) and phillips head screwdriver.

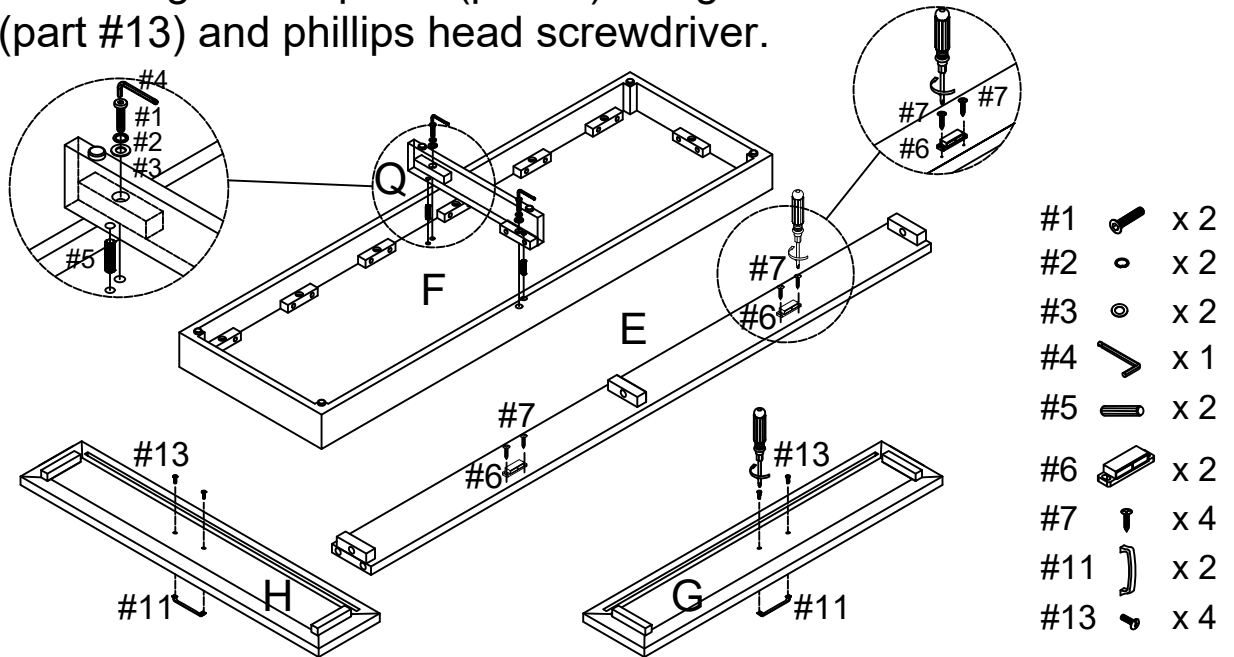

Step 2. Attach straight door hinges (part #8) and spring door hinges (part #9) to left door panels (part M) and right door panels (part N) using screws (part #10) and phillips head screwdriver.

Attach handles (part #11) to left door panels (part M) and right door panels (part N) using long round head bolts (part #12) and phillips head screwdriver.

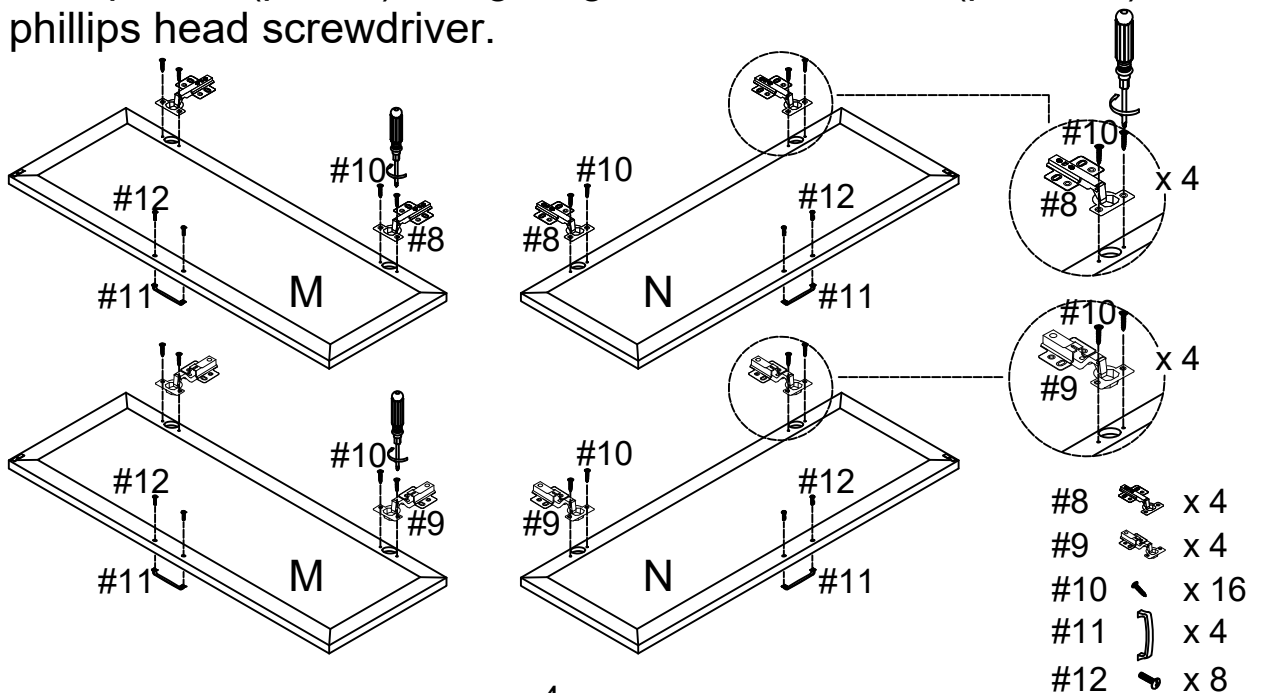

Step 3. Attach drawer panels (parts I2 & J2) to drawer left front panel (part G) and drawer right front panel (part H) using long screws (part #17) and phillips head screwdriver. Slide drawer bottom panels (part L2) into the grooves of assembled units (parts G, H, I2 & J2). Attach drawer back panels (part K2) to assembled units (parts I2, J2 & L2) using long screws (part #17) and phillips head screwdriver.

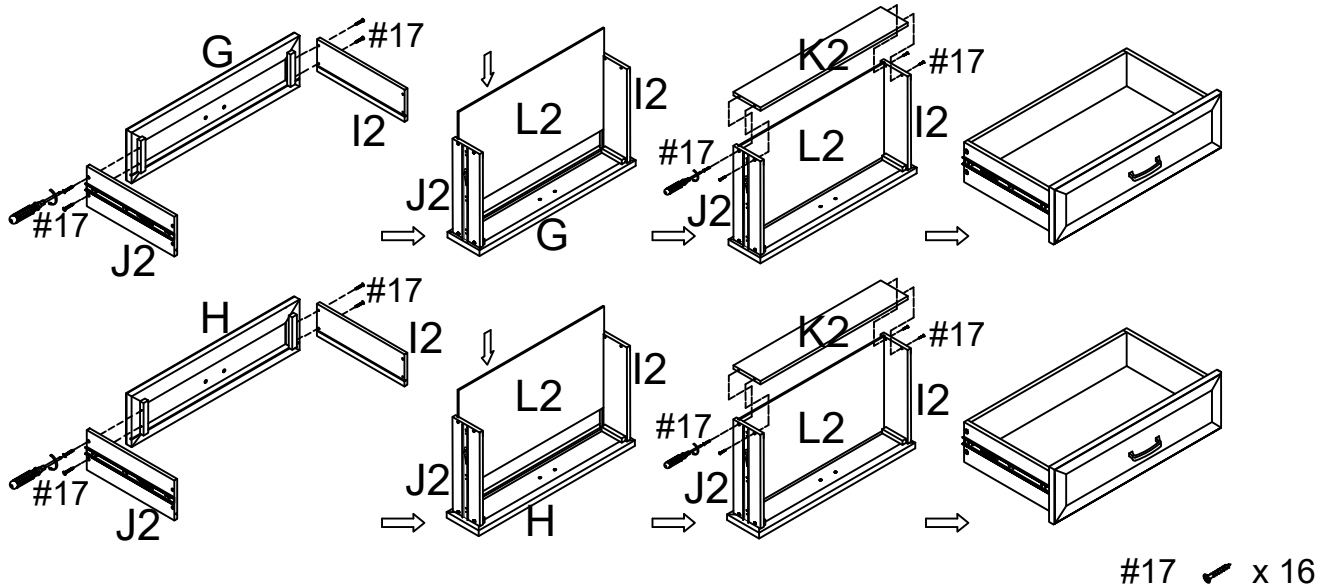

Step 4. Attach cross rail (part E) to partition panel (part C2) using bolt (part #1), spring washer (part #2), flat washer (part #3) and allen wrench (part #4). Attach left panel (part B) and right panel (part D) to cross rail (part E) using wood dowels (part #5), bolts (part #1), spring washers (part #2), flat washers (part #3) and allen wrench (part #4).

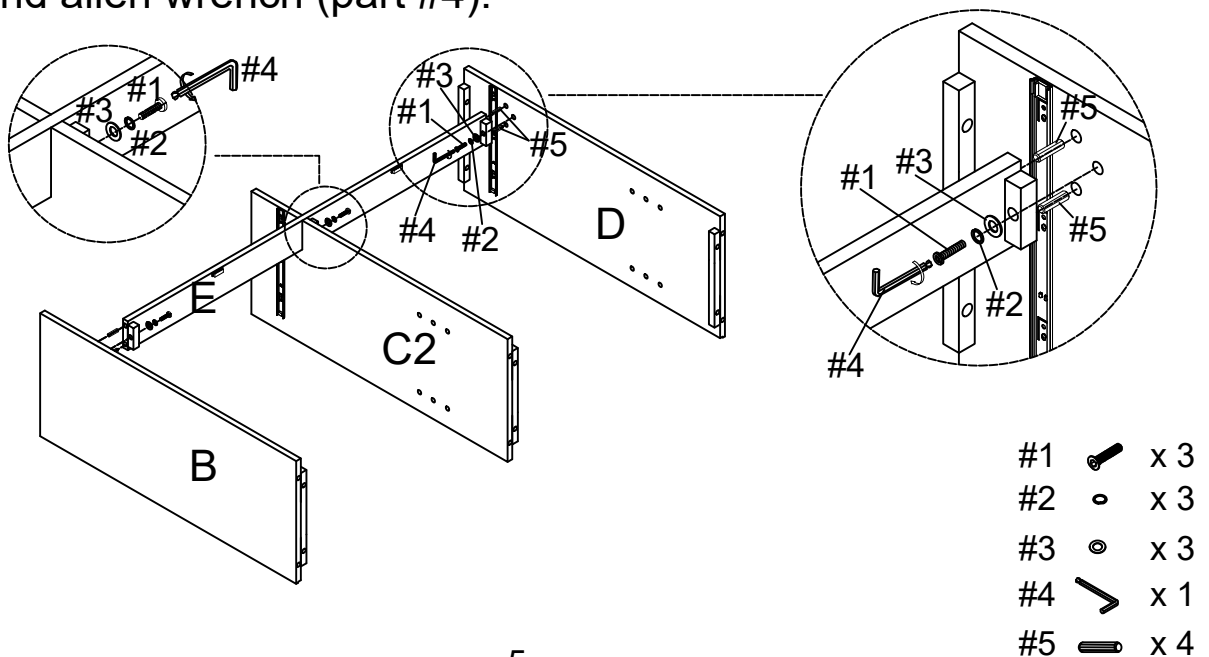

Step 5. Attach top panel (part A) to assembled unit (parts B, C2 & D) using wood dowels (part #5), bolts (part #1), spring washers (part #2), flat washers (part #3) and allen wrench (part #4).

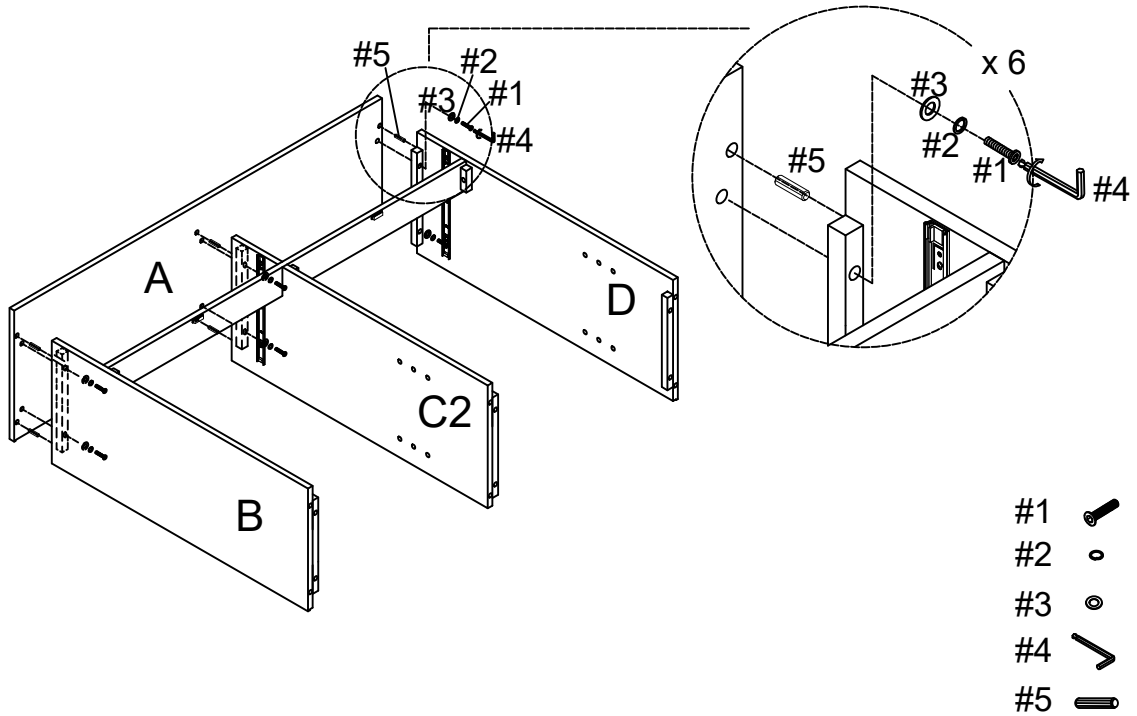

Step 6. Attach bottom panel (part F) to assembled unit (parts B, C2 & D) using wood dowels (part #5), bolts (part #1), spring washers (part #2), flat washers (part #3) and allen wrench (part #4).

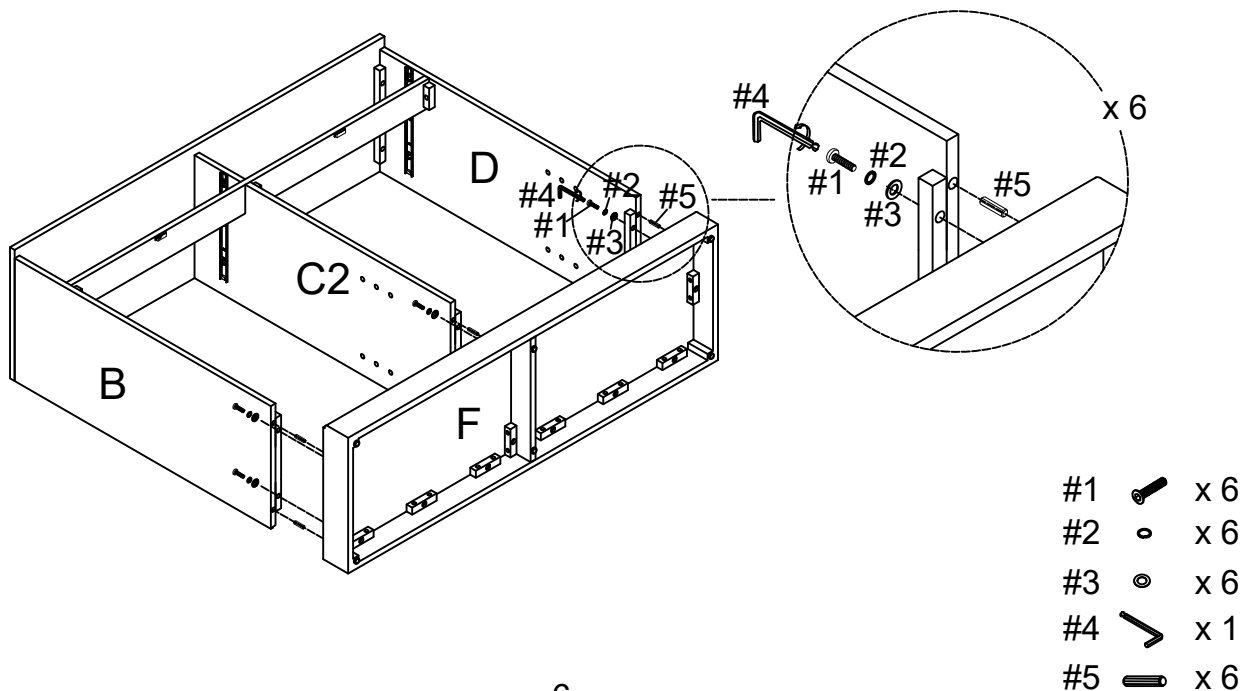

Step 7. Attach cover (part S2) to back panels (part O2 & R2)
using binding posts (part #18) and small allen wrench (part #19).

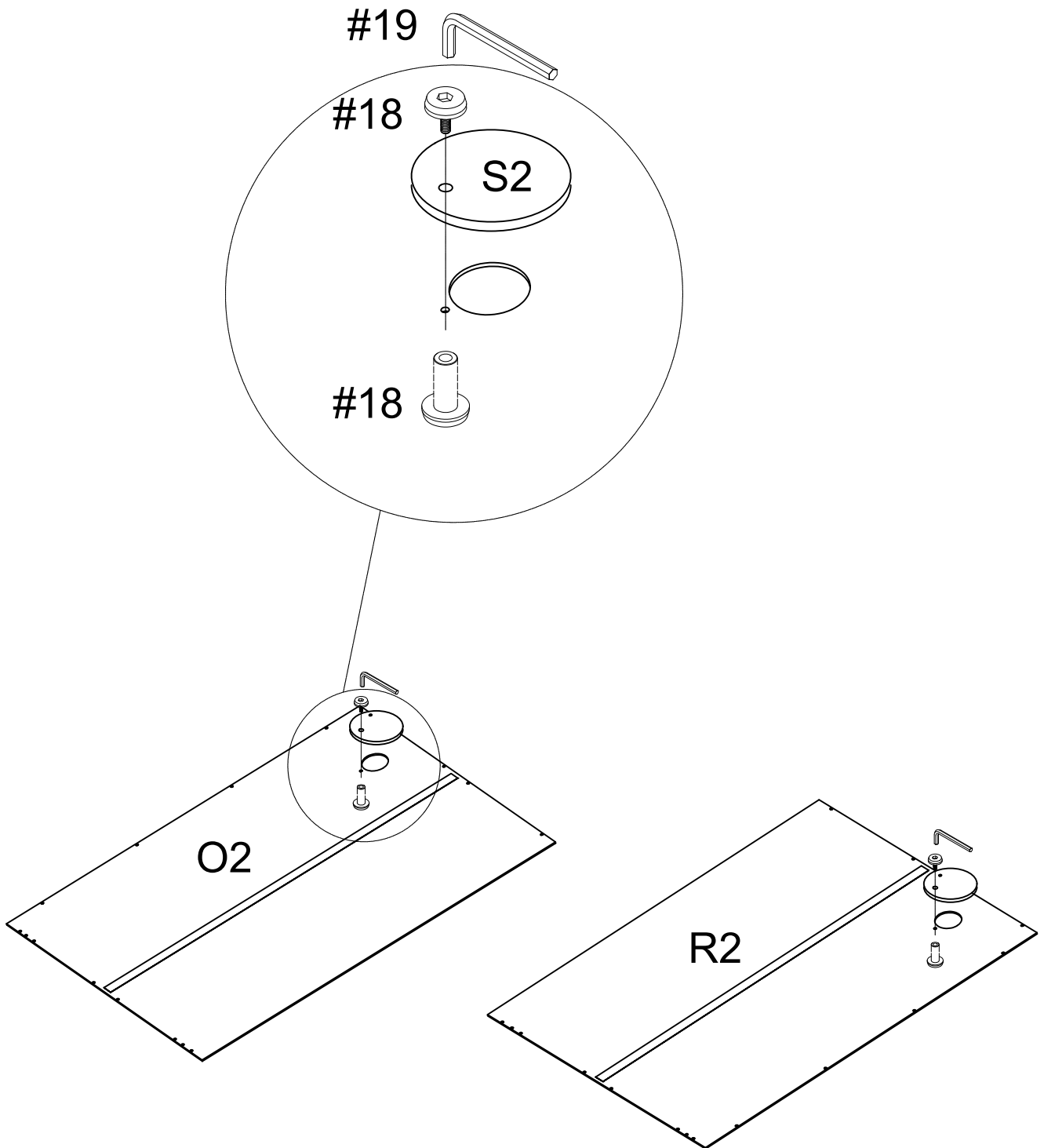

#18  x 2
#19  x 1

Step 8. Carefully turn unit upright. Attach back panels (part O2 & R2) to assembled unit (parts A, B, C2, D & F) using short screws (part #15) and phillips head screwdriver.

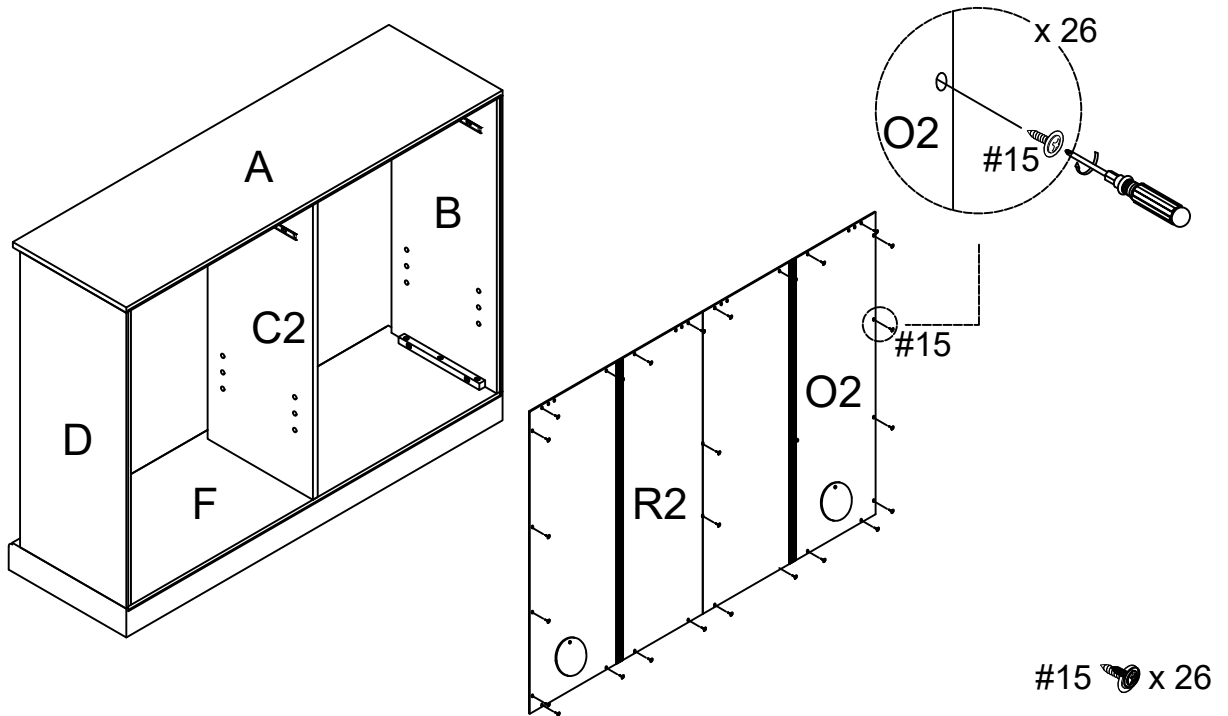

Step 9. Place shelf holders (part #14) into desired position and slide adjustable shelves (part P2) and assembled drawers into place.
 Note: To release trigger disconnect levers push one side up and the other down.

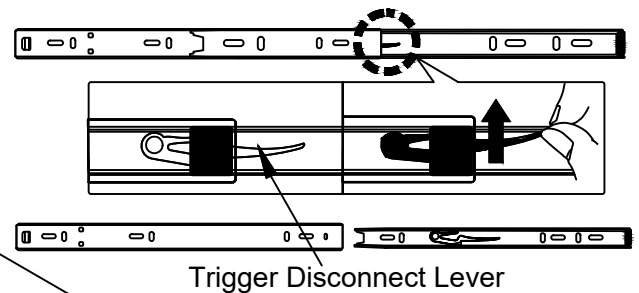

Move the sliders to the front end of rail before sliding the drawer into place.

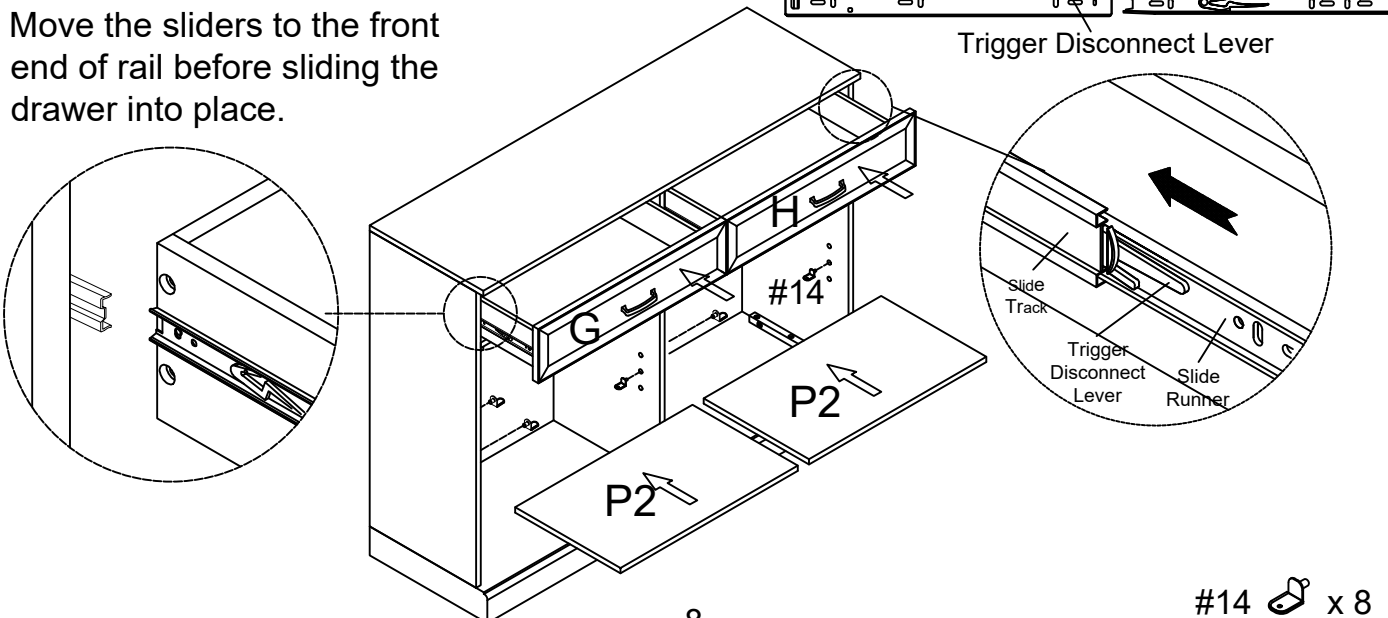





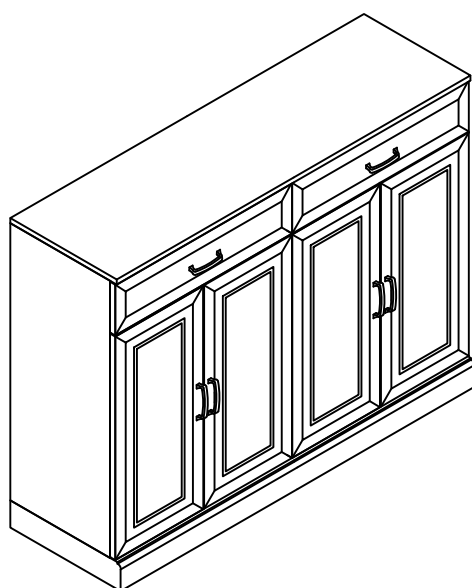
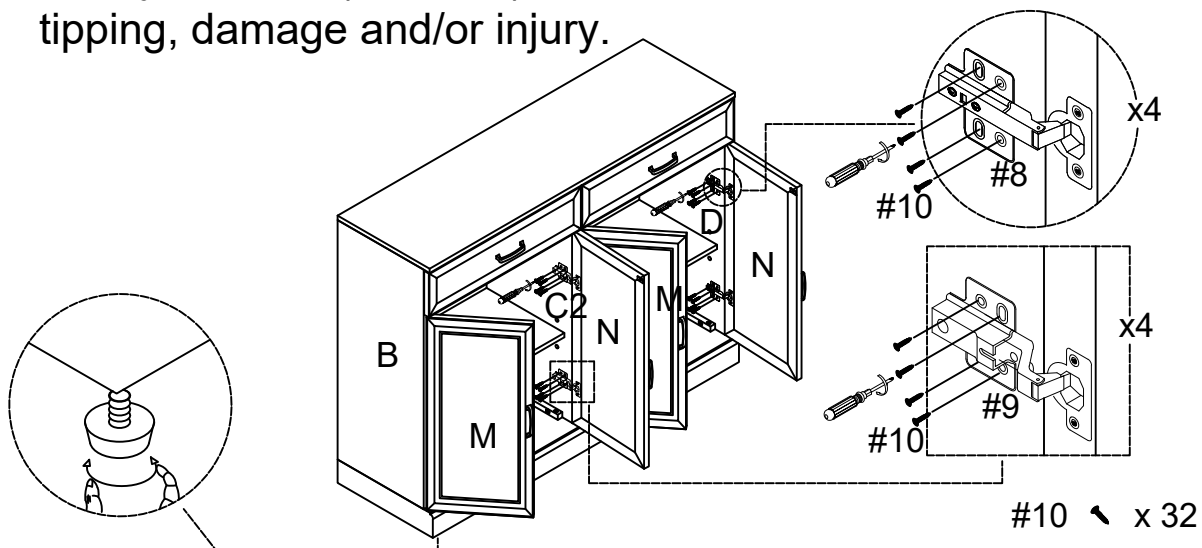

Step 10. Attach door panels (parts M & N) to panels (parts B & D) and partition panel (part C2) using screws (part #10) and phillips head screwdriver.

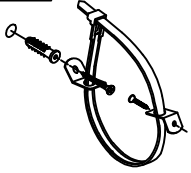
NOTE: It is important to adjust levelers once fully assembled and upright. Extend adjustable leveler until it's firmly in contact with the floor. If relocating, adjust leveler as needed until it's firmly in contact with the floor in new location.

Important: Safety strap kit (part #16) must be installed to prevent tipping, damage and/or injury.



#16	A	B	C	D	E
					
Safety Strap Kit 1 SET	Wall Anchor 1 PC	Bracket 2 PCS	Short Screw 1 PC	Long Screw 1 PC	Safety Wall Strap 1 PC

SAFETY WALL STRAP INSTALLATION

Note: It is highly recommended to install this safety strap kit to prevent tipping, damage and/or injury.

1. Insert short screw (C) and safety wall strap (E) through bracket (B) and attach to top panel (part A) using phillips head screwdriver.
2. Drill a 11/32" hole where you want to secure the unit. The drilled hole will be at the same height as the hole in top panel (part A) where bracket (B) is attached. Tap wall anchor (A) into the hole.
3. Insert long screw (D) and safety wall strap (E) through bracket (B) into wall anchor (A) using phillips head screwdriver.

Note: This item is not intended for clothing storage use.

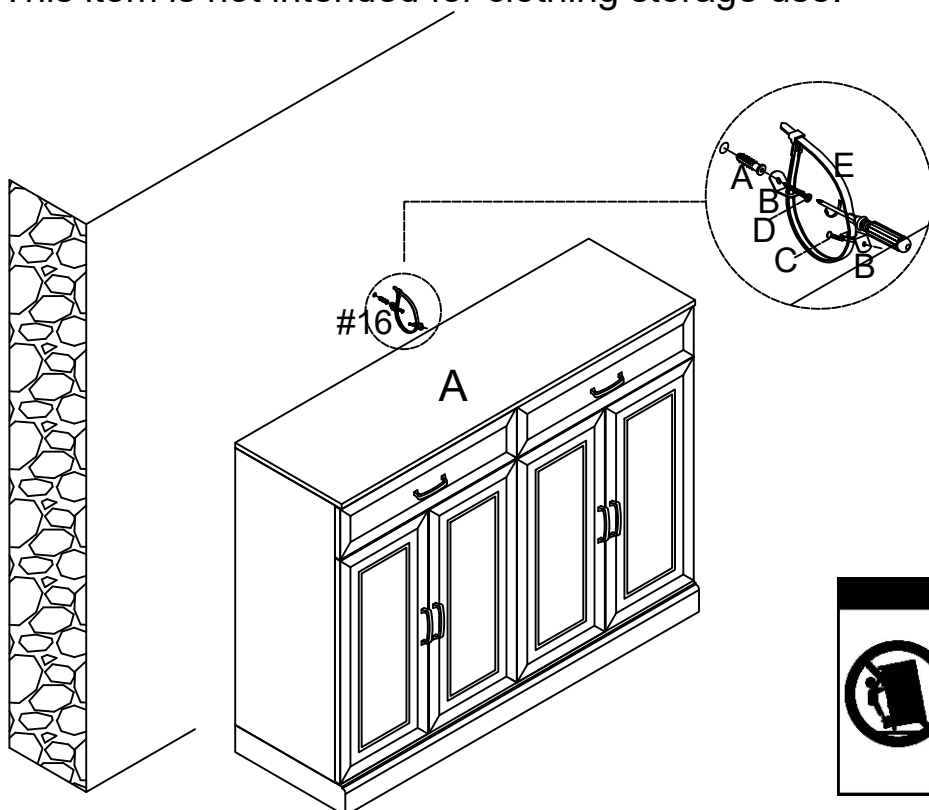

ADJUST YOUR DOORS TO MAKE THE GAPS MORE EVEN (OPTIONAL).

STEP 1

Open the door.

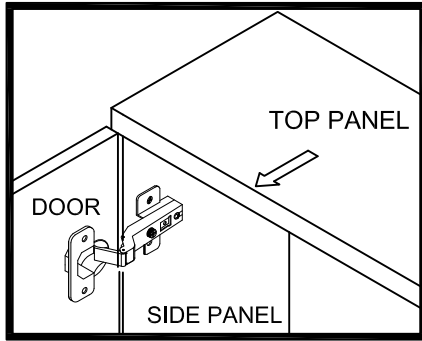

STEP 2

Adjust the gap between door panel and side panel

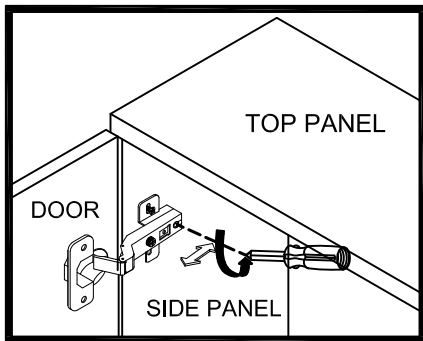

Loosen the screw indicated a little, adjust the hinge to right position (see step 2a & 2b), then tighten the screw.

STEP 2a MOVE DOOR IN

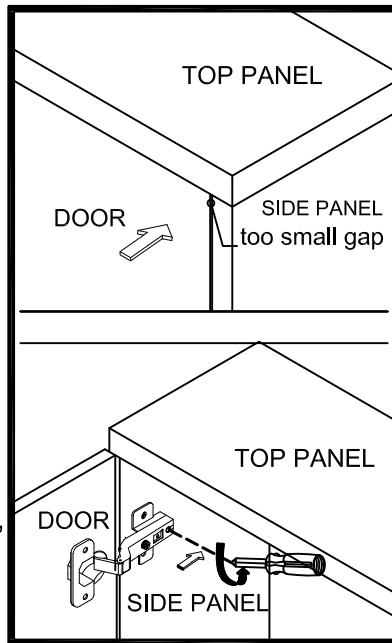

Push the hinge back a little.

STEP 2b MOVE DOOR OUT

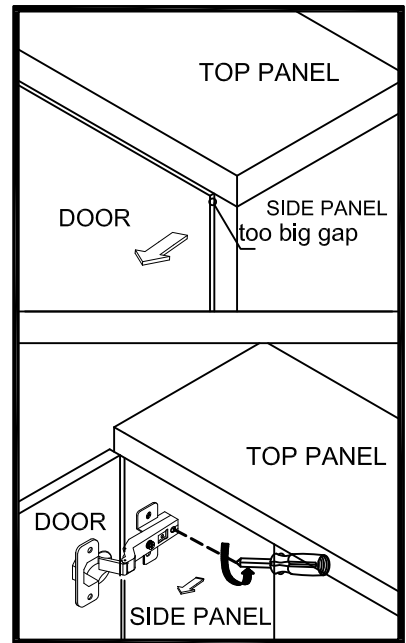

Pull the hinge forward a little.

STEP 3

To adjust the gap between two door

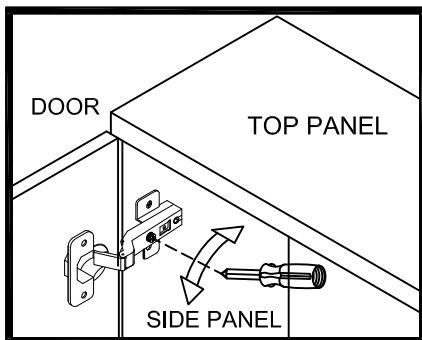

Loosen or tighten the screw indicated a little to adjust the gap between doors panels (see step 3a & step 3b)

STEP 3a MOVE DOOR RIGHT

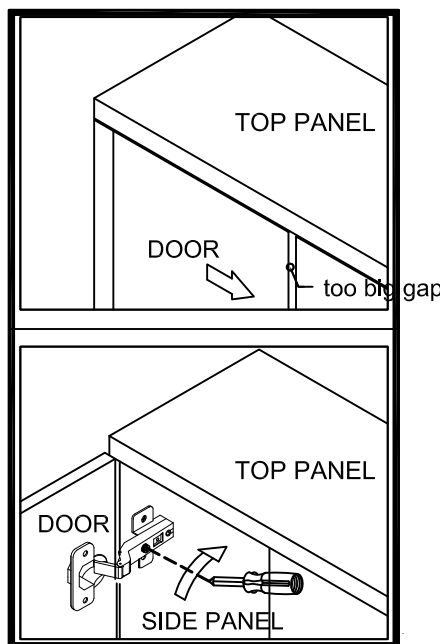

Turn the screw clockwise a little as shown to make the gap small.

STEP 3b MOVE DOOR LEFT

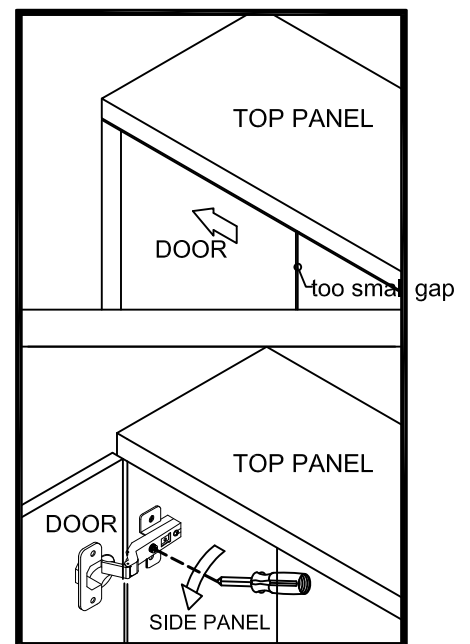

Turn the screw counterclockwise a little as shown to make the gap big.