

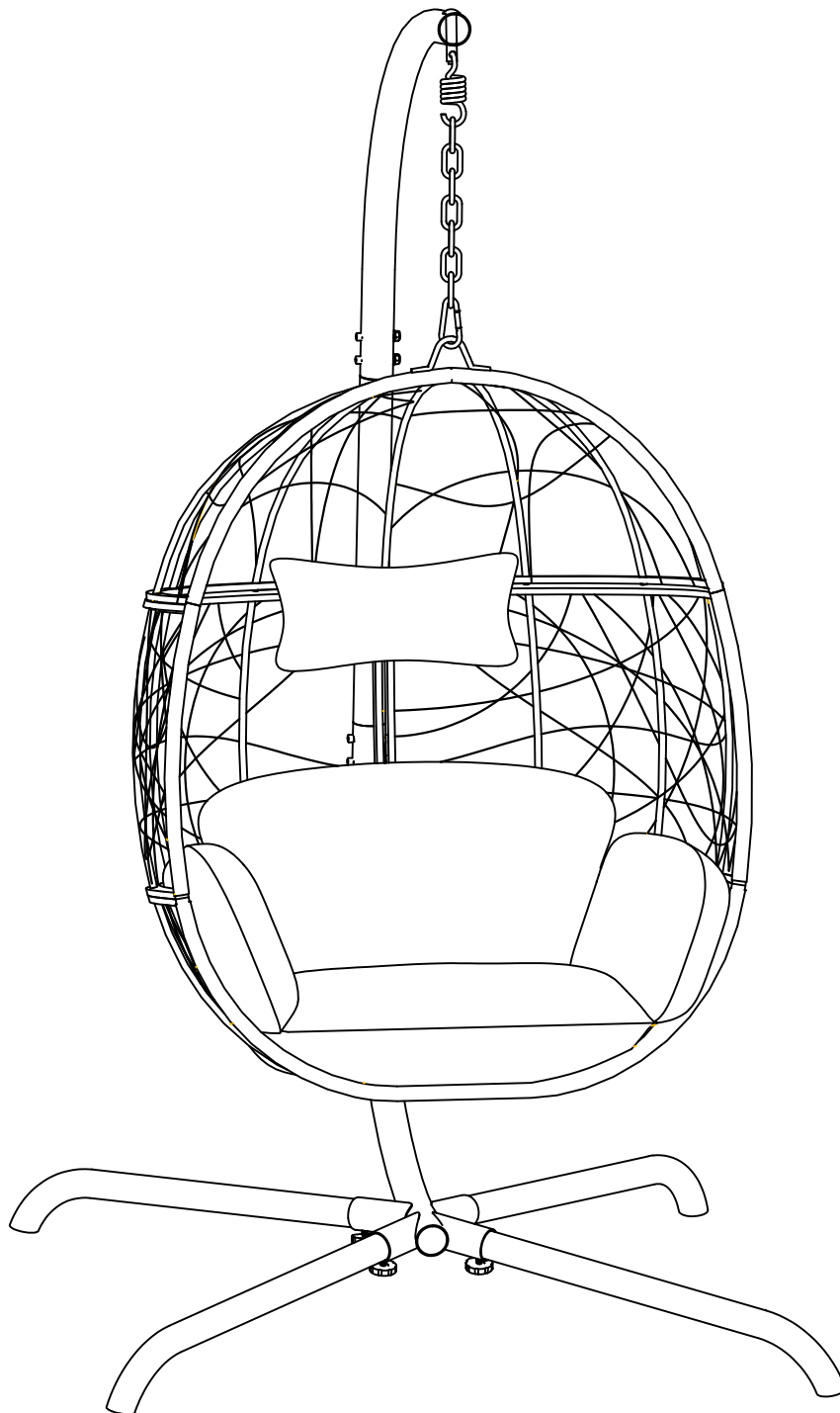









# Assembly Instruction

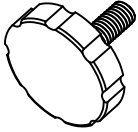

Unlimited Creativity, Astonishing Quality, Excellent Service

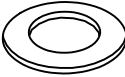
# READ BEFORE INSTALLATION

1. If you encounter any problems, such as missing accessories or damaged parts please contact us and send us pictures in time, our after-sale team will reply you within 24 hours.
2. 2 persons needed for assembly.
3. Using an electric drill in slow mode, Our allen wrench is preferred.
4. DO NOT tighten the screws completely until align all the screws with the holes.

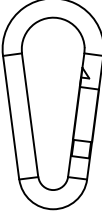
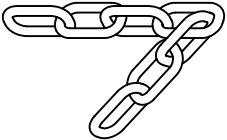
<p>1</p>  <p>M8 1pc</p>	<p>2</p>  <p>M6 2pcs</p>	<p>3</p>  <p>M8 1pc</p>	<p>4</p>  <p>M8 4pcs</p>
<p>5</p>  <p>M6 9pcs</p>	<p>6</p>  <p>M8 4pcs</p>	<p>7</p>  <p>M8 4pcs</p>	<p>8</p>  <p>M8 4pcs</p>
<p>9</p>  <p>1pc</p>	<p>10</p>  <p>1pc</p>	<p>11</p>  <p>1pc</p>	<p>12</p>  <p>1pc</p>

A

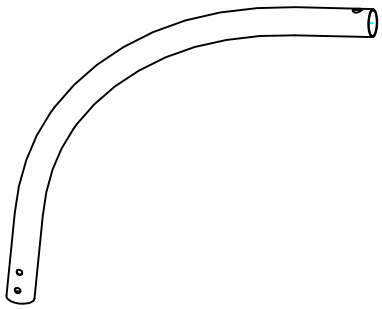

1pc

E

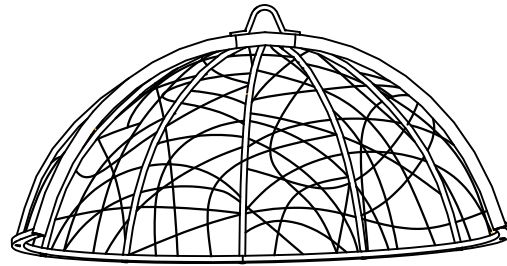

1pc

B

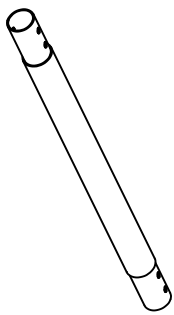

1pc

F

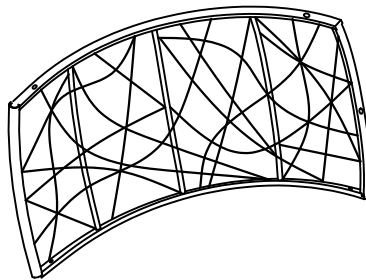

1pc

G

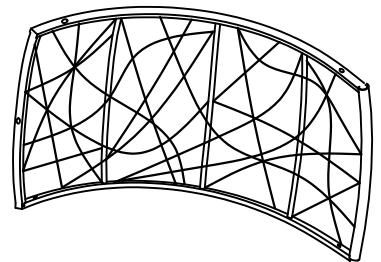

1pc

C

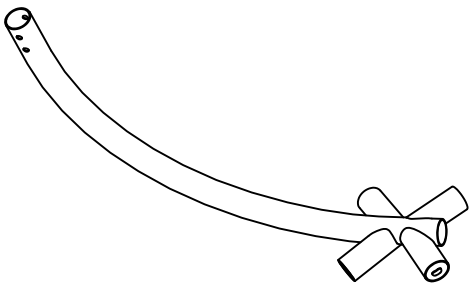

1pc

H

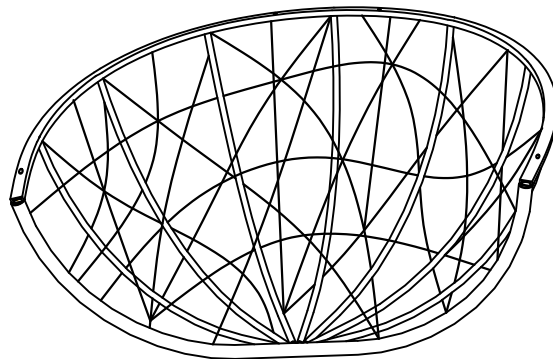

1pc

D

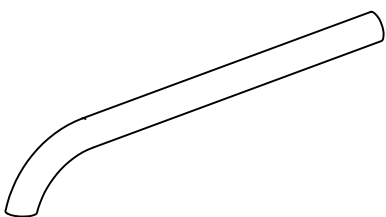

4pcs

I

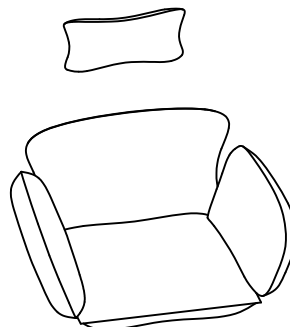

SEAT CUSHION

1pc

1

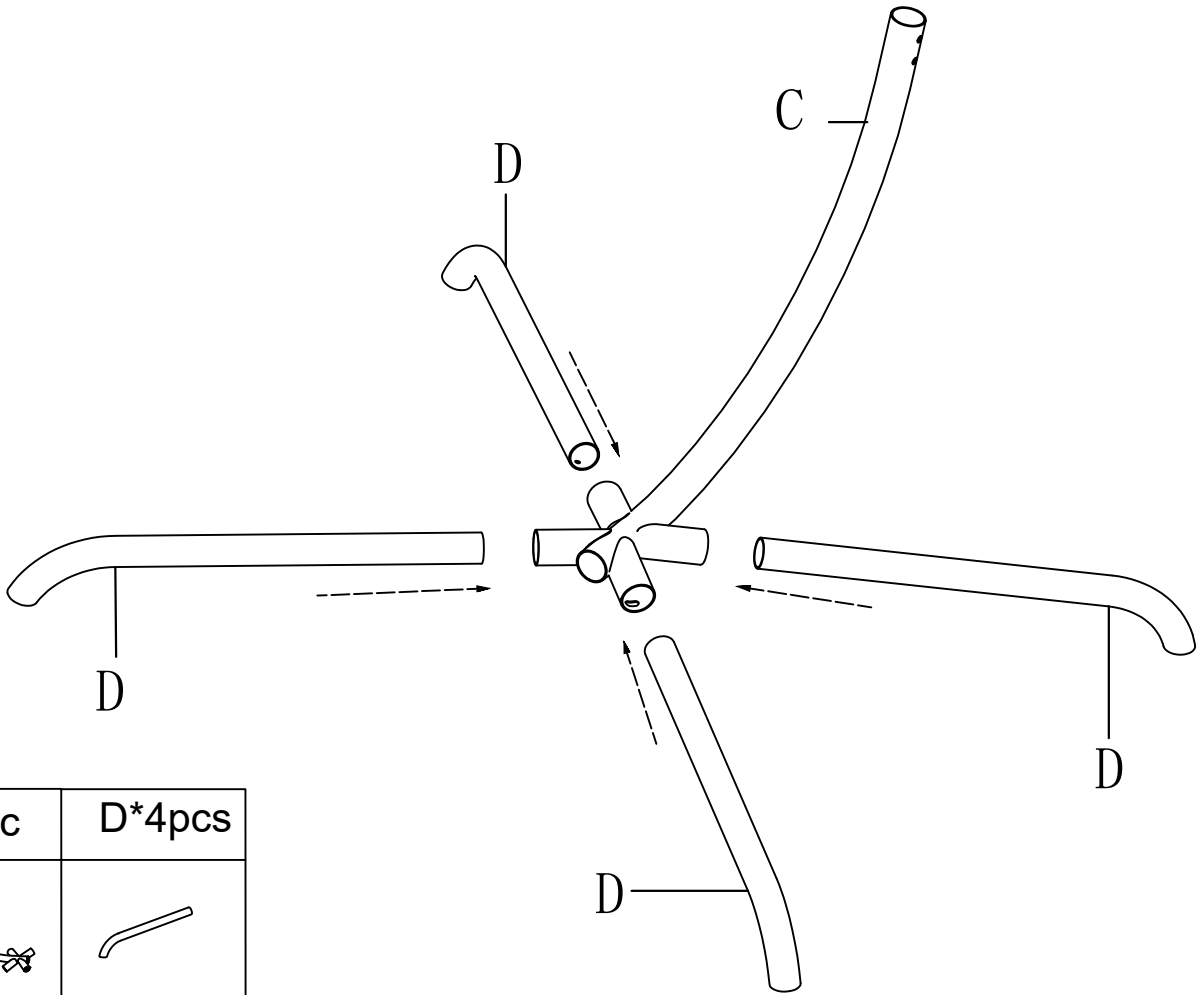

C\*1pc

D\*4pcs



2

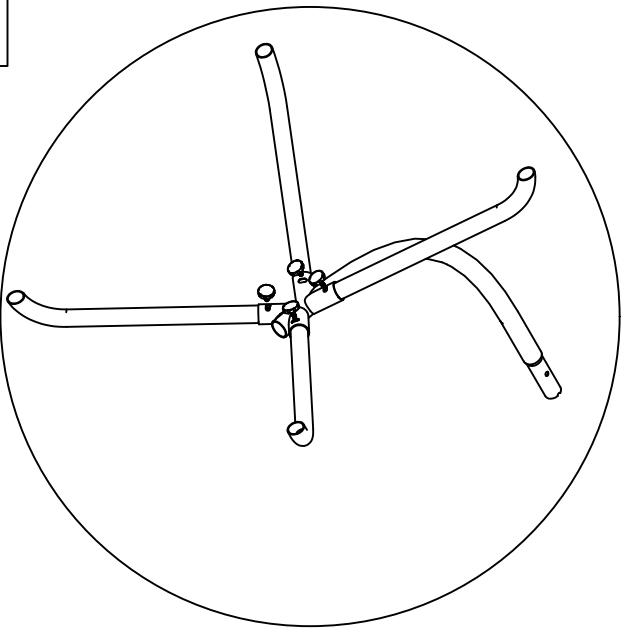

4\*4pcs





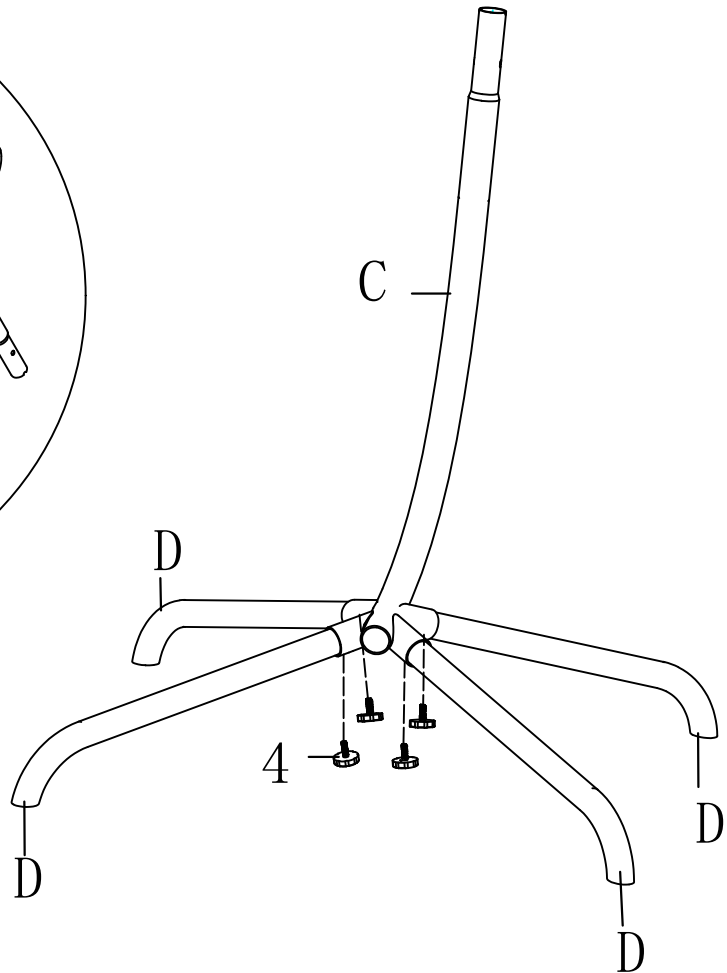



M8

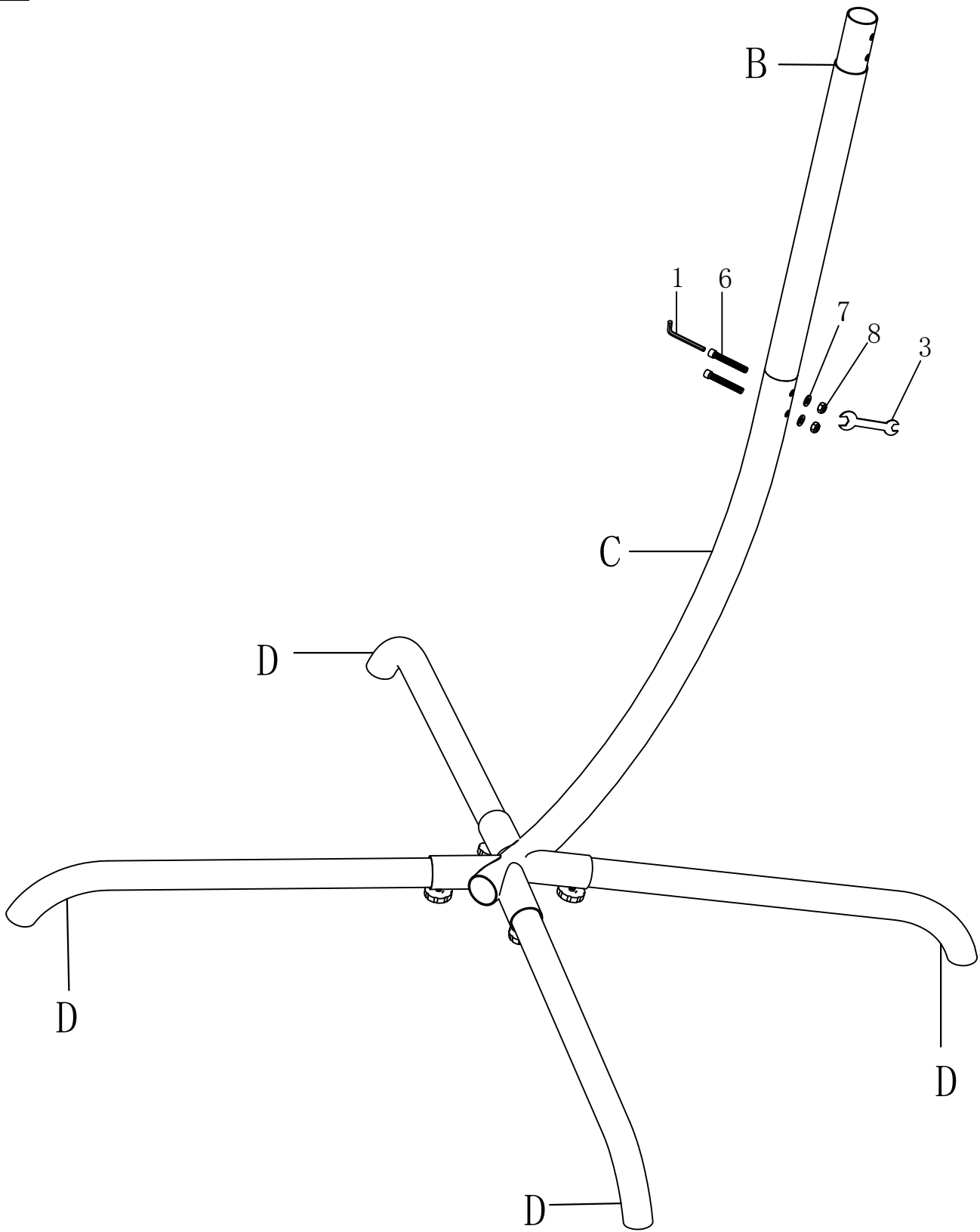





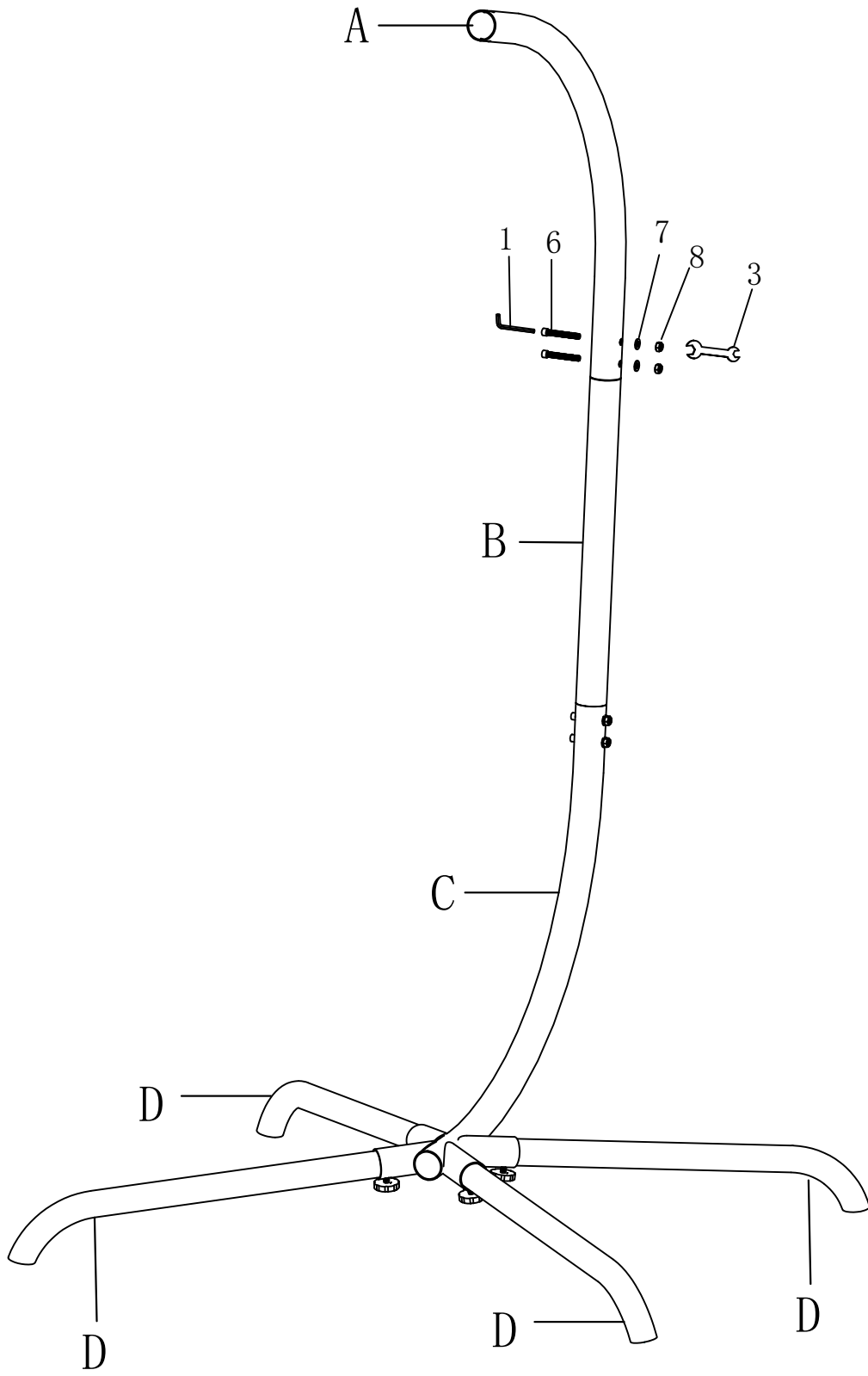

5

3

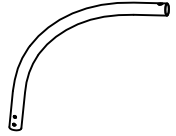

B*1pc	6*2pcs	7*2pcs	8*2pcs	1*1pc	3*1pc
	 M8	 M8	 M8	 M8	 M8



A*1pc	6*2pcs	7*2pcs	8*2pcs	1*1pc	3*1pc
					
	M8	M8	M8	M8	M8

5\*2pcs



M6

2\*2pcs



M6

F\*1pc

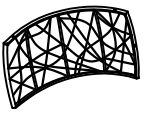

H\*1pc

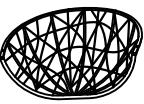

**5**

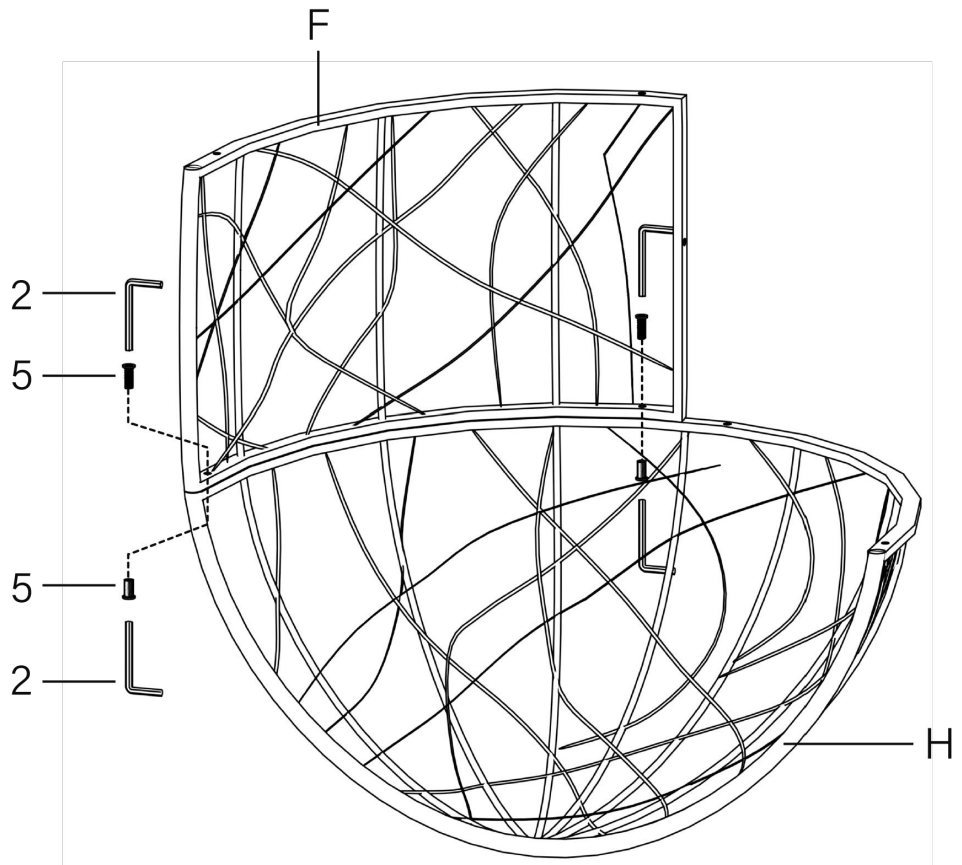

**6**

5\*3pcs



M6

2\*2pcs



M6

G\*1pcs

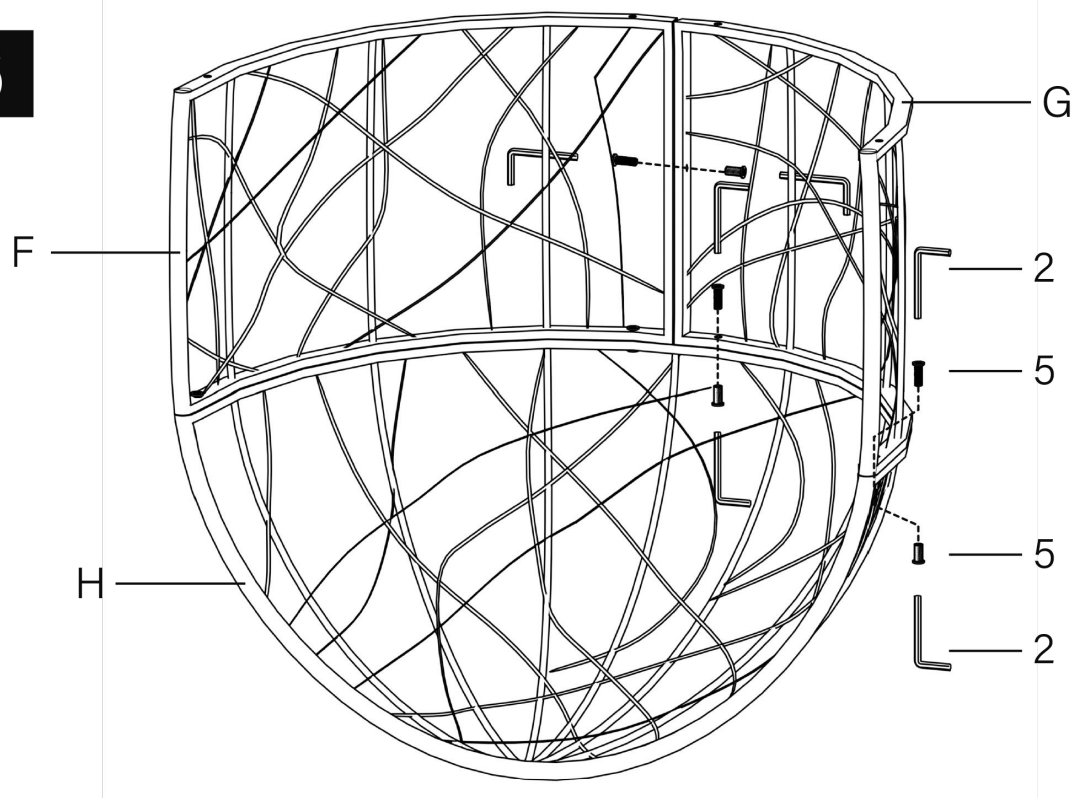
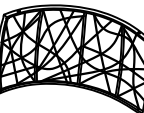

7

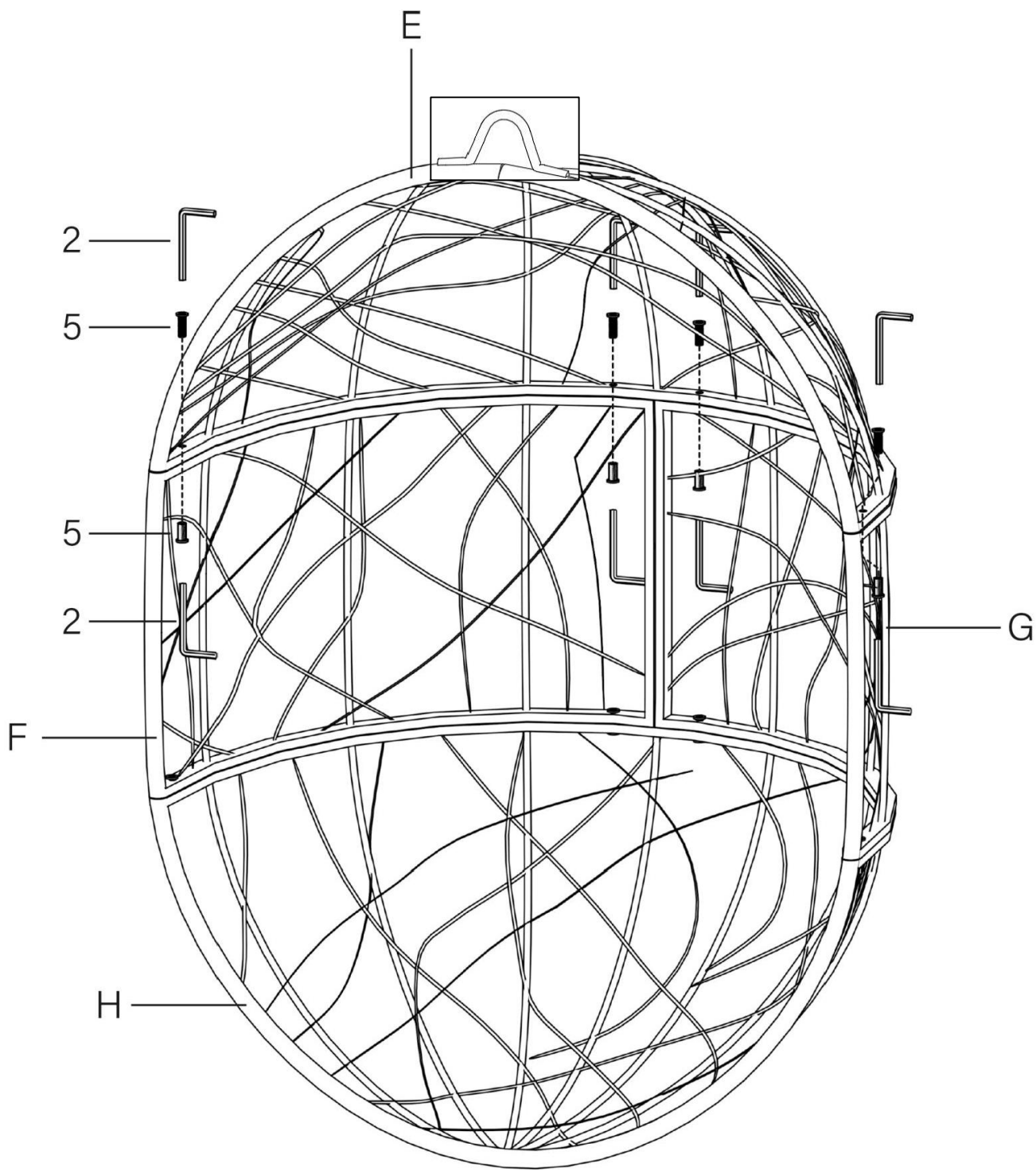

5\*4pcs

2\*2pcs

E\*1pc



M6

8

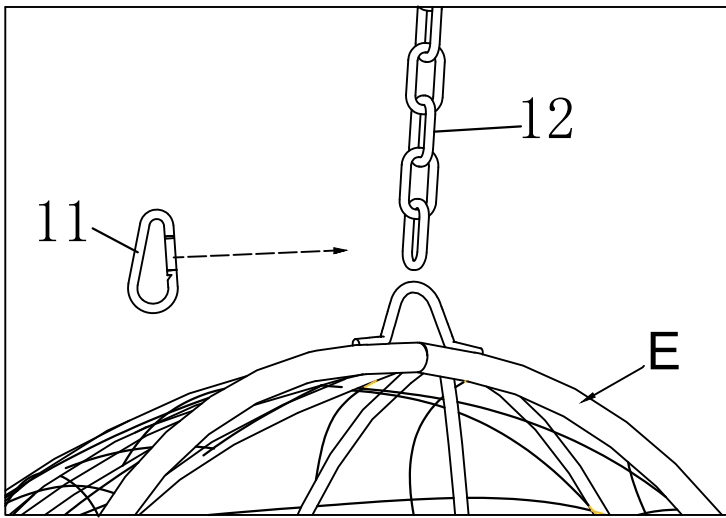

9

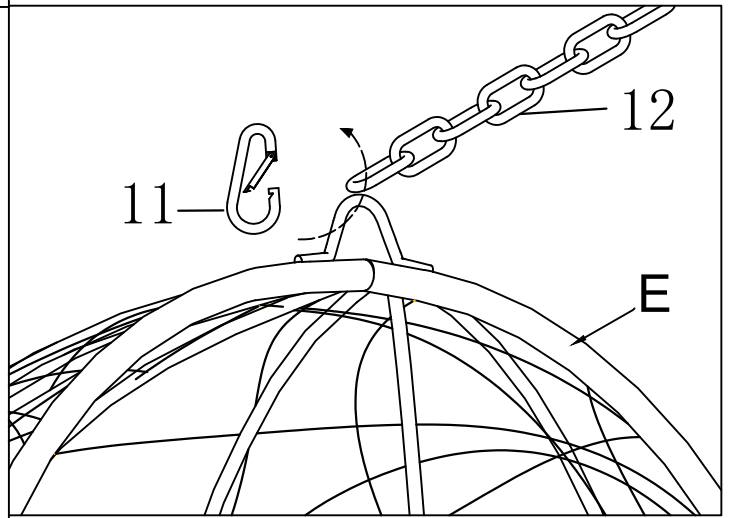

10

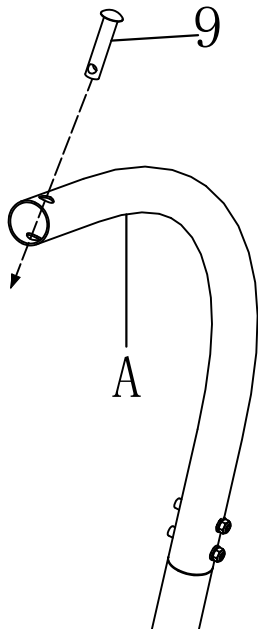

11

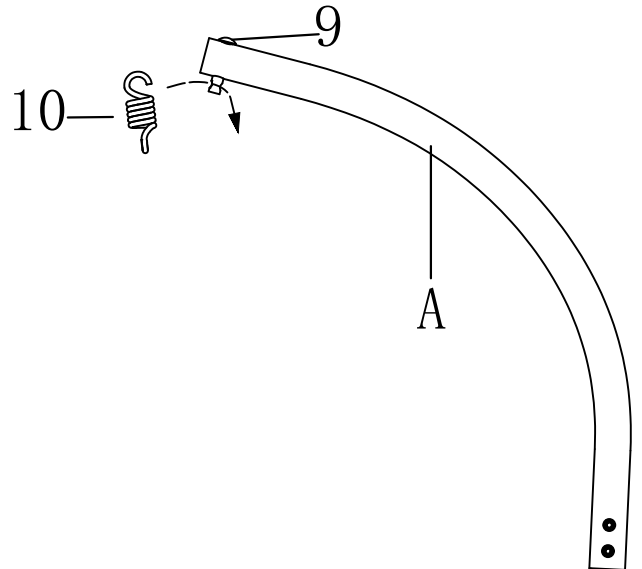

12

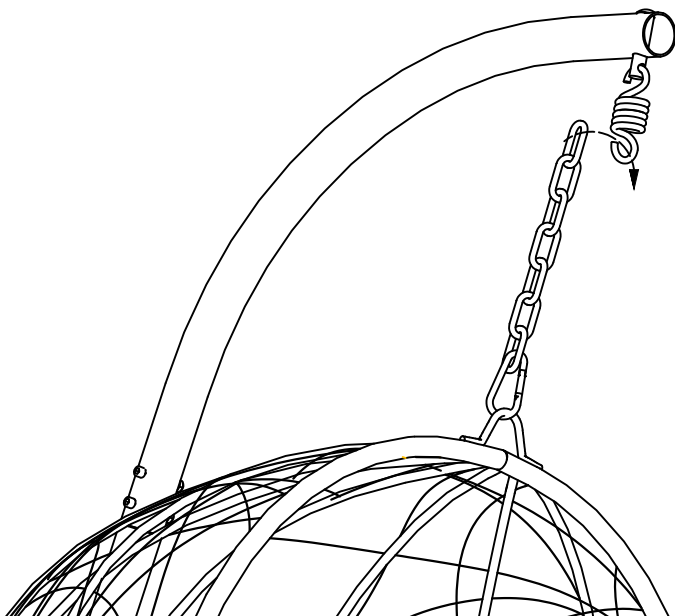

11\*1pc

12\*1pc

9\*1pc



10\*1pc



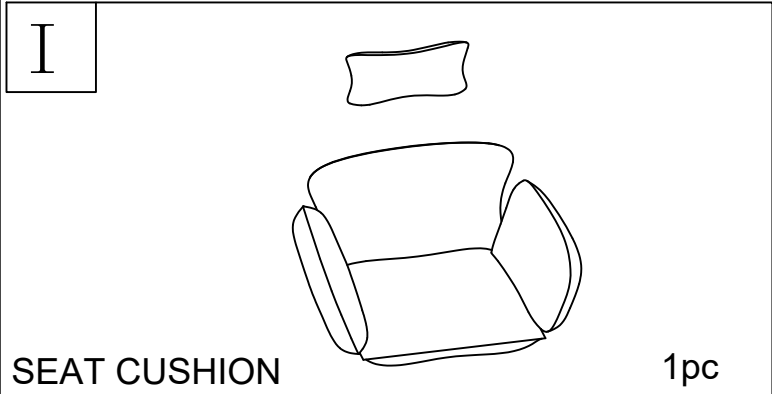
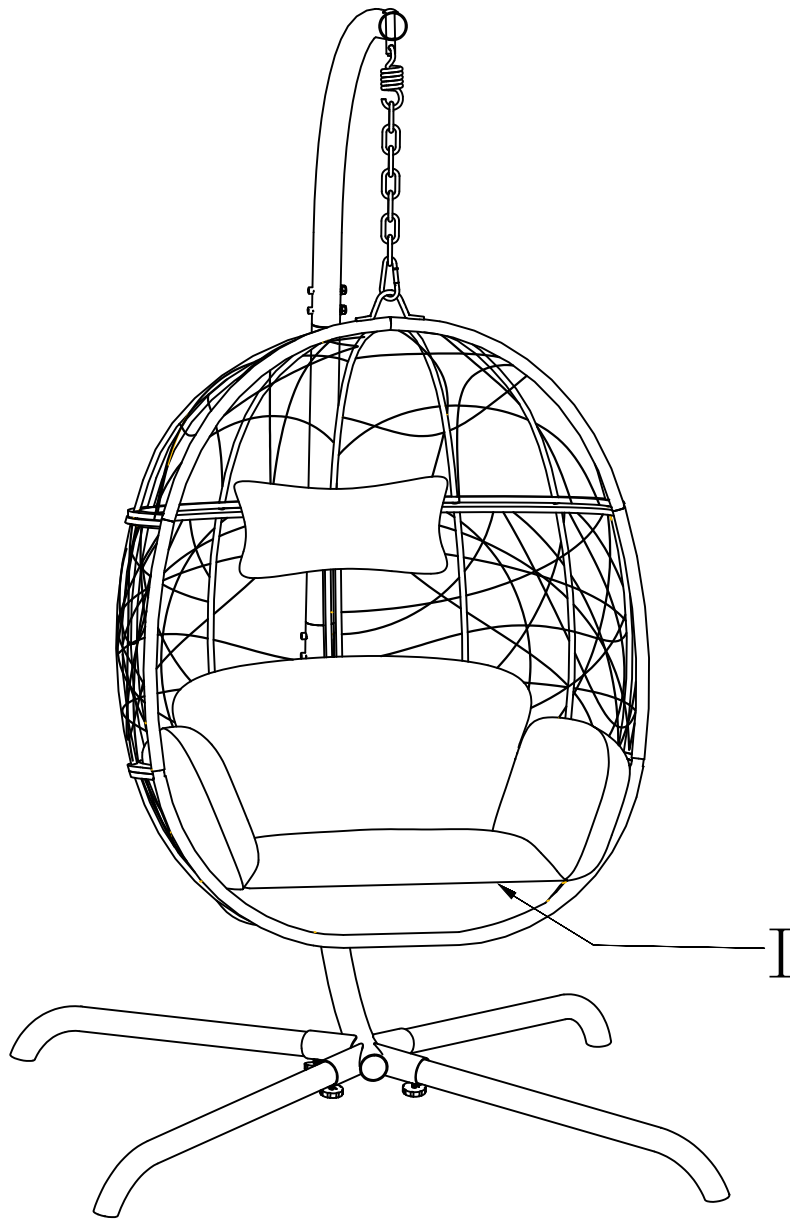

Do not fully tighten all screws until assembly is completed.