

# Product Installation Instructions

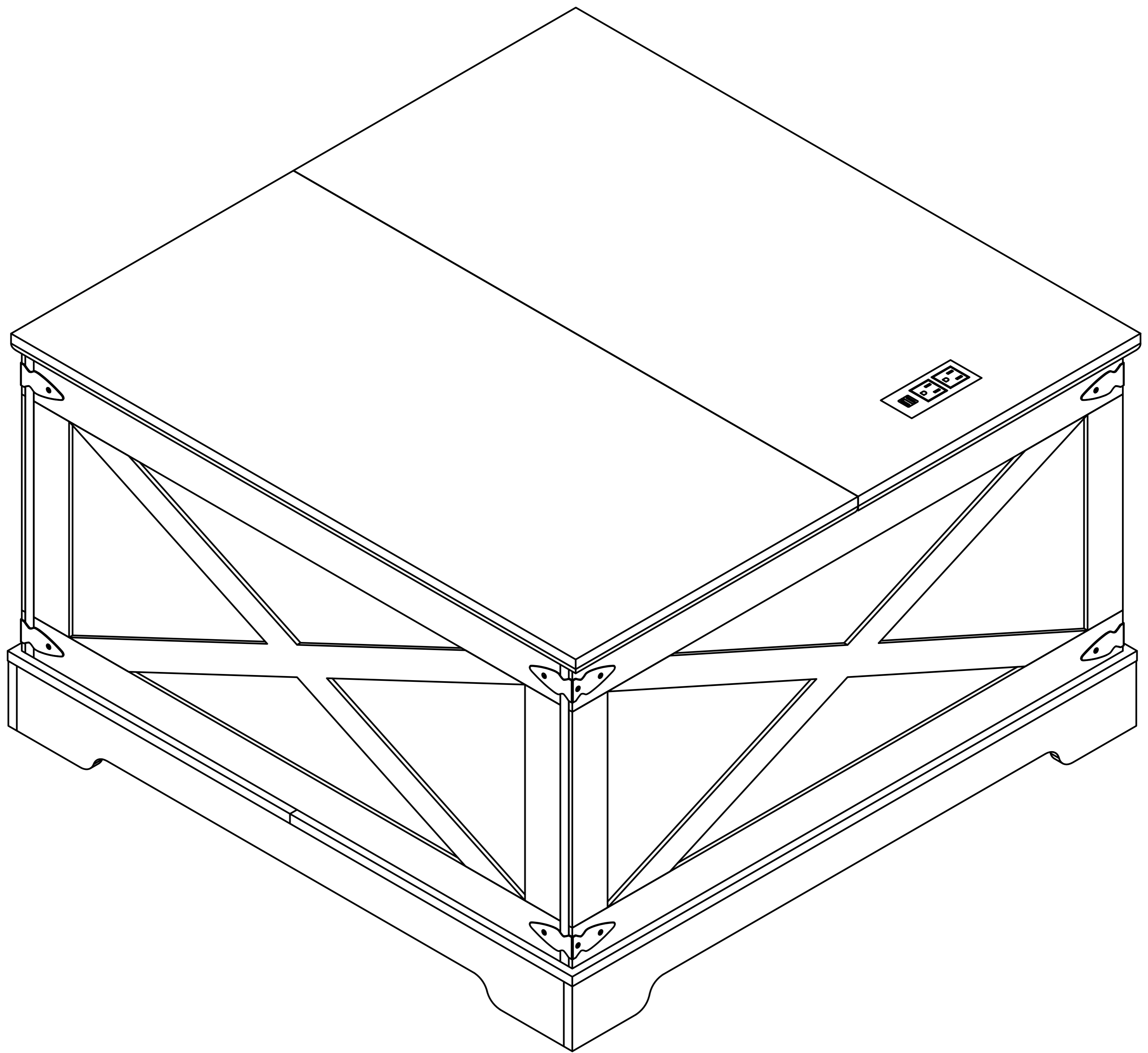

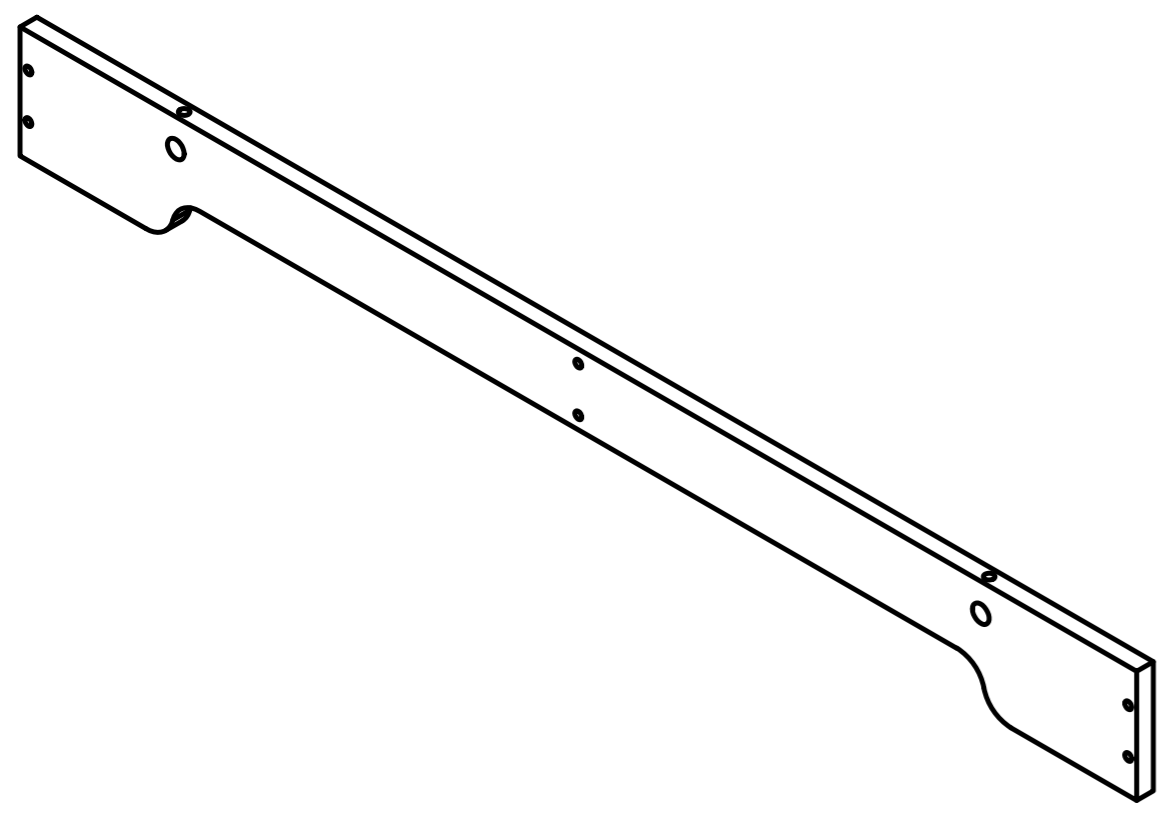

**Ax2**

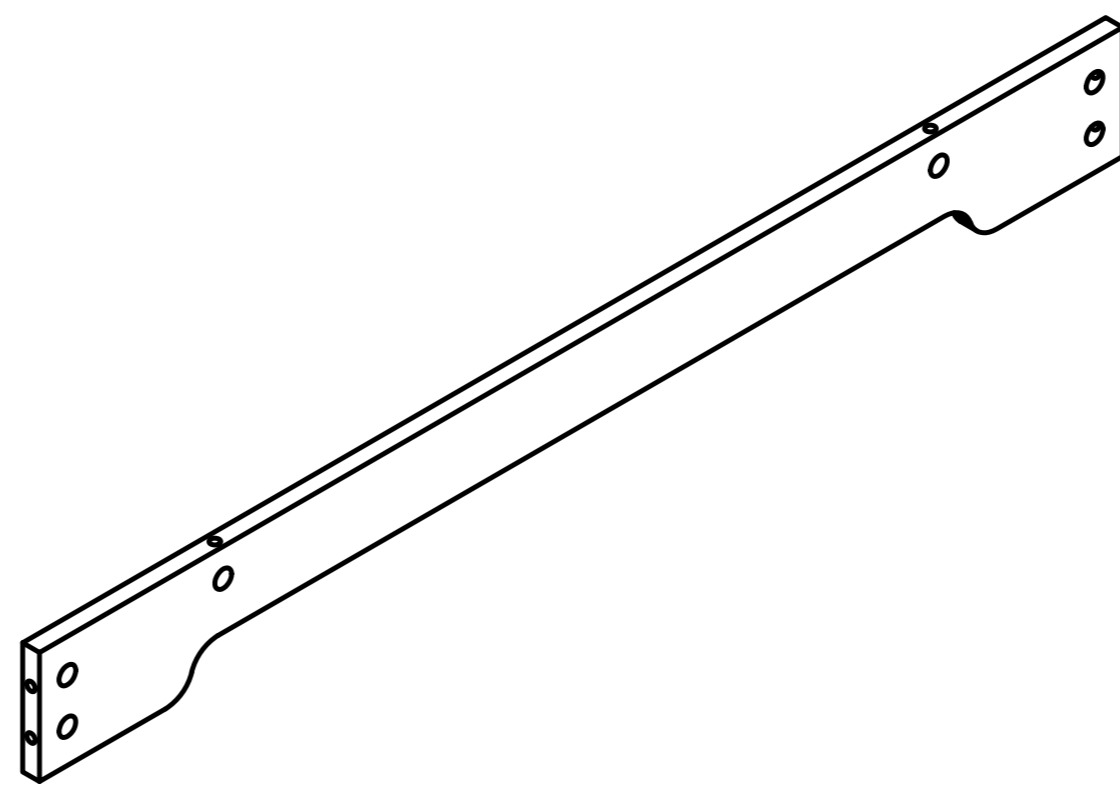

**Bx2**

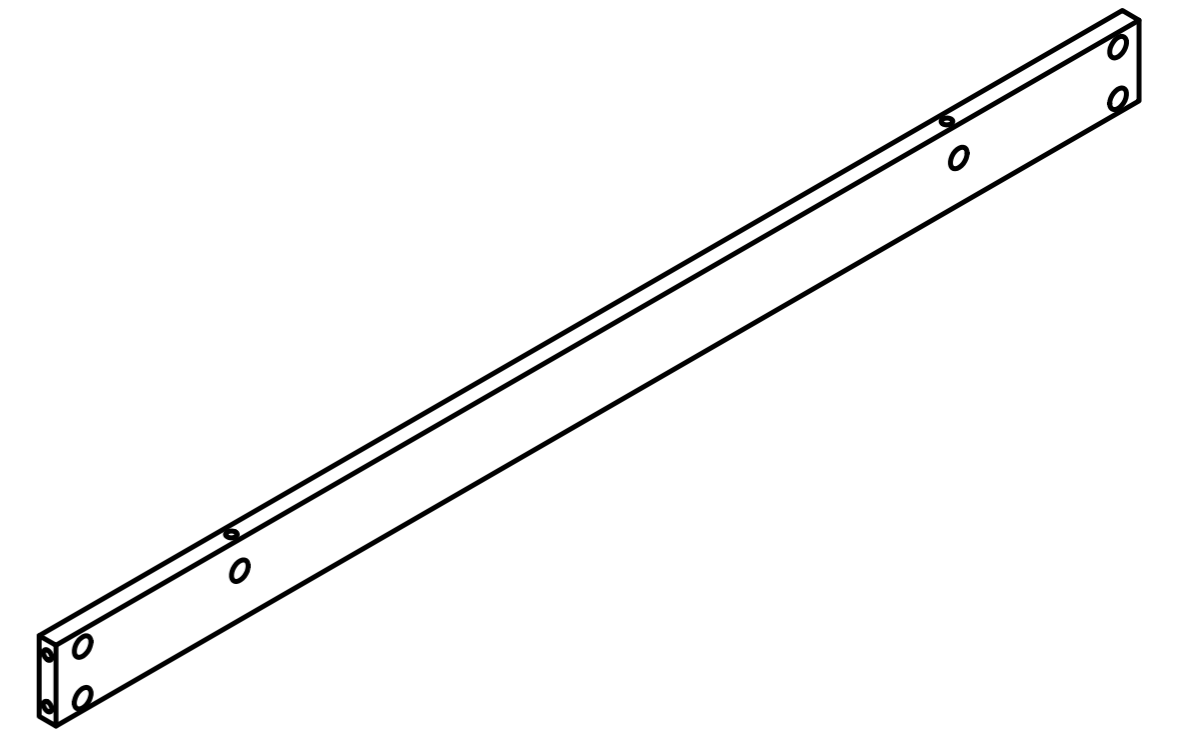

**Cx1**

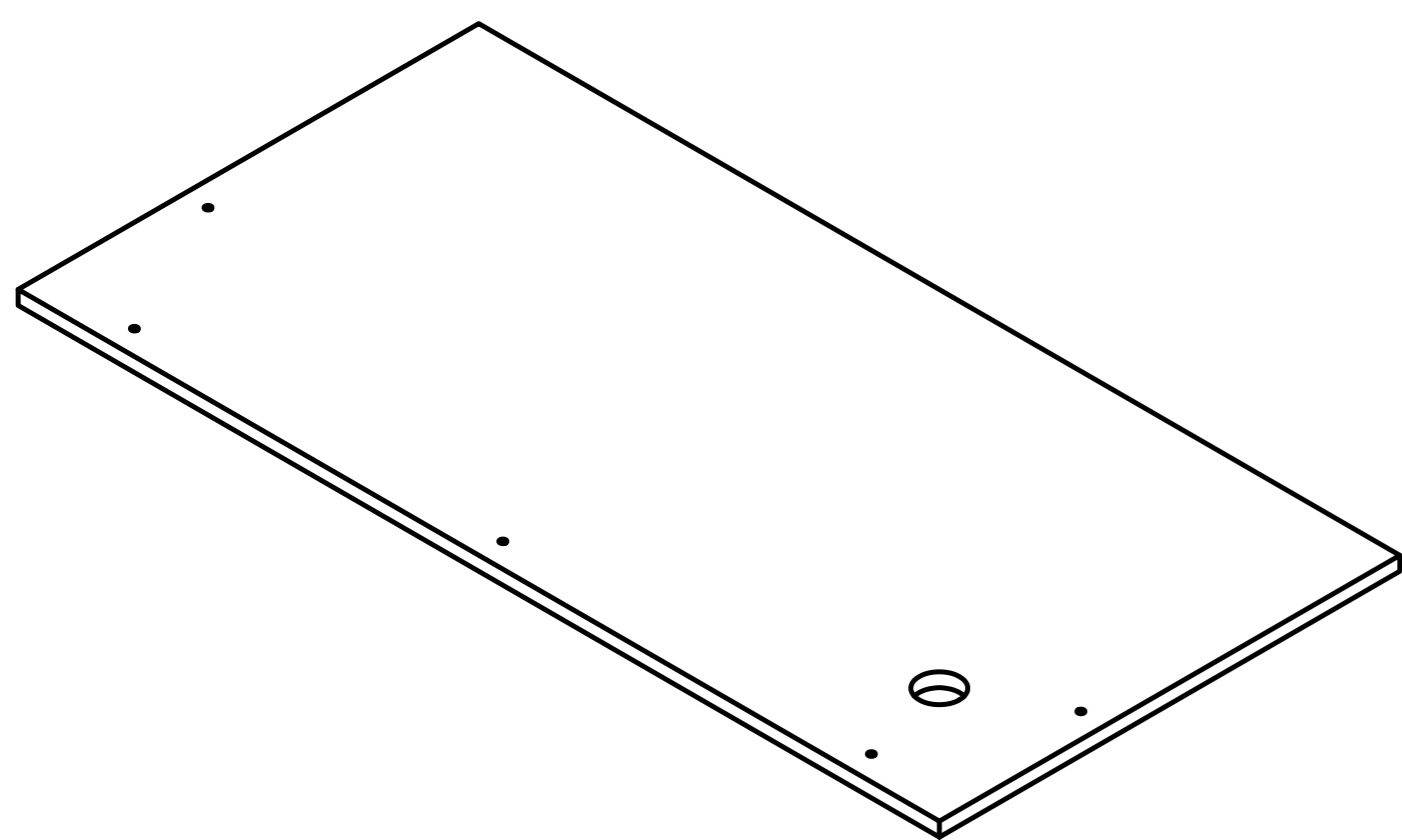

**Dx1**

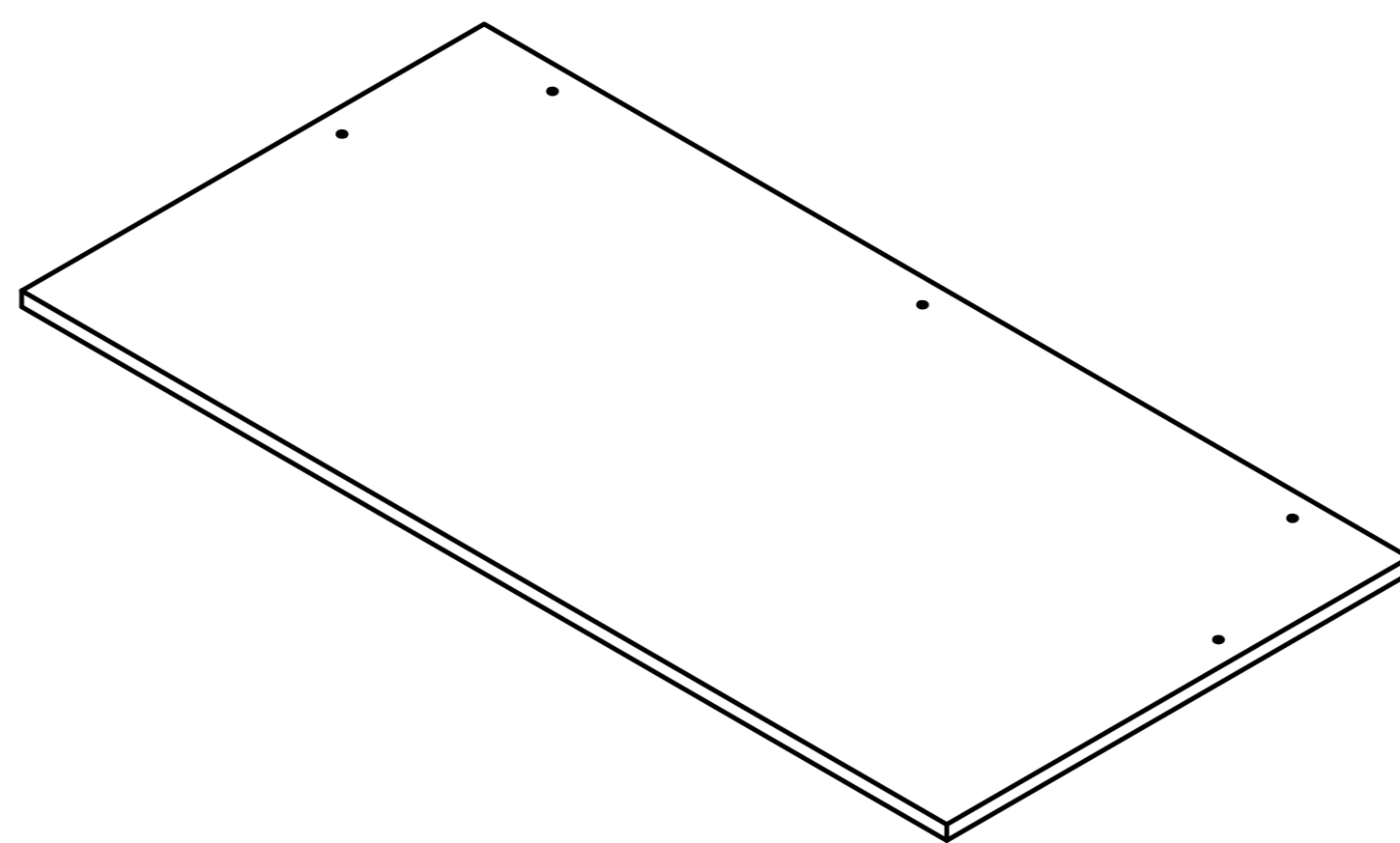

**Ex1**

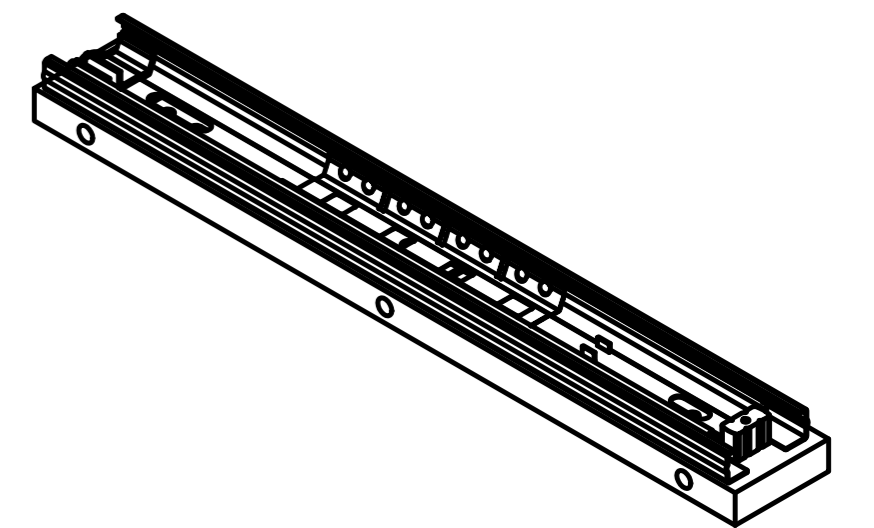

**F1x1**

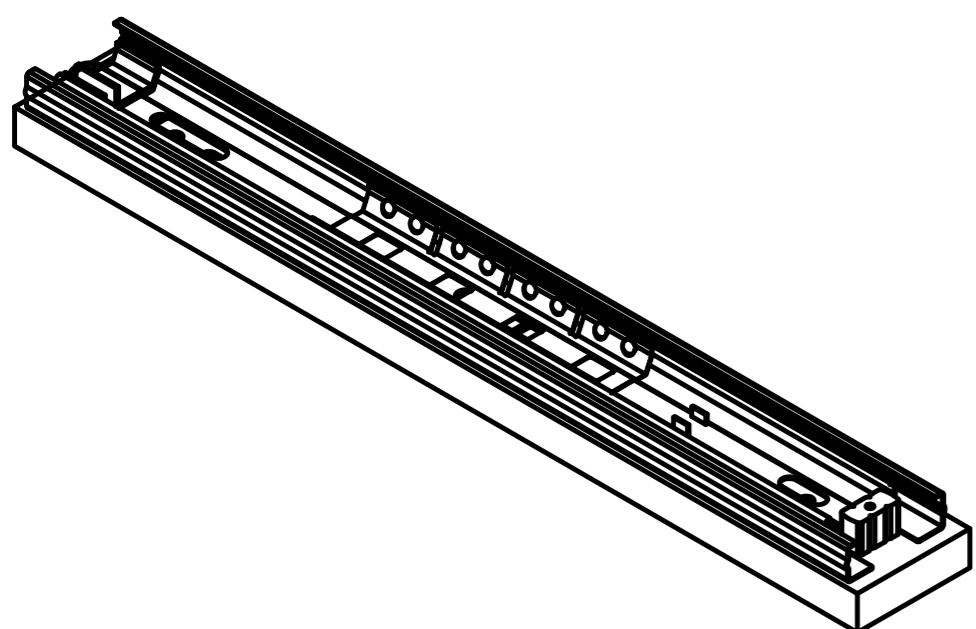

**F2x1**

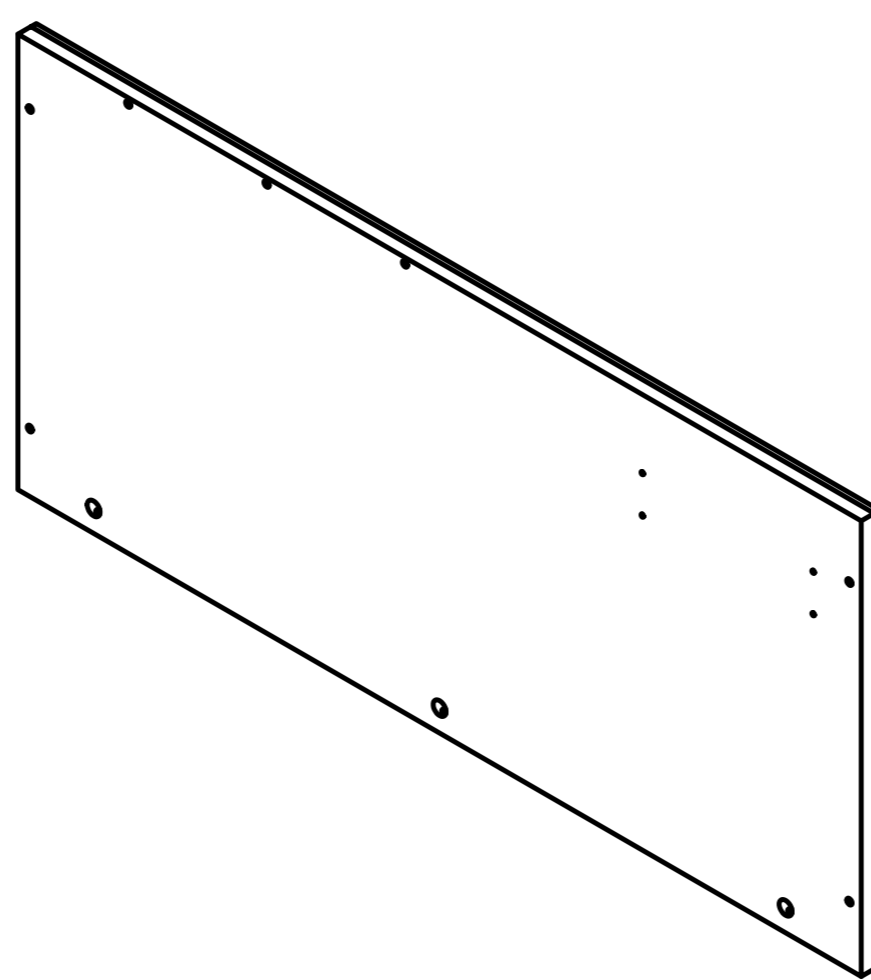

**Gx1**

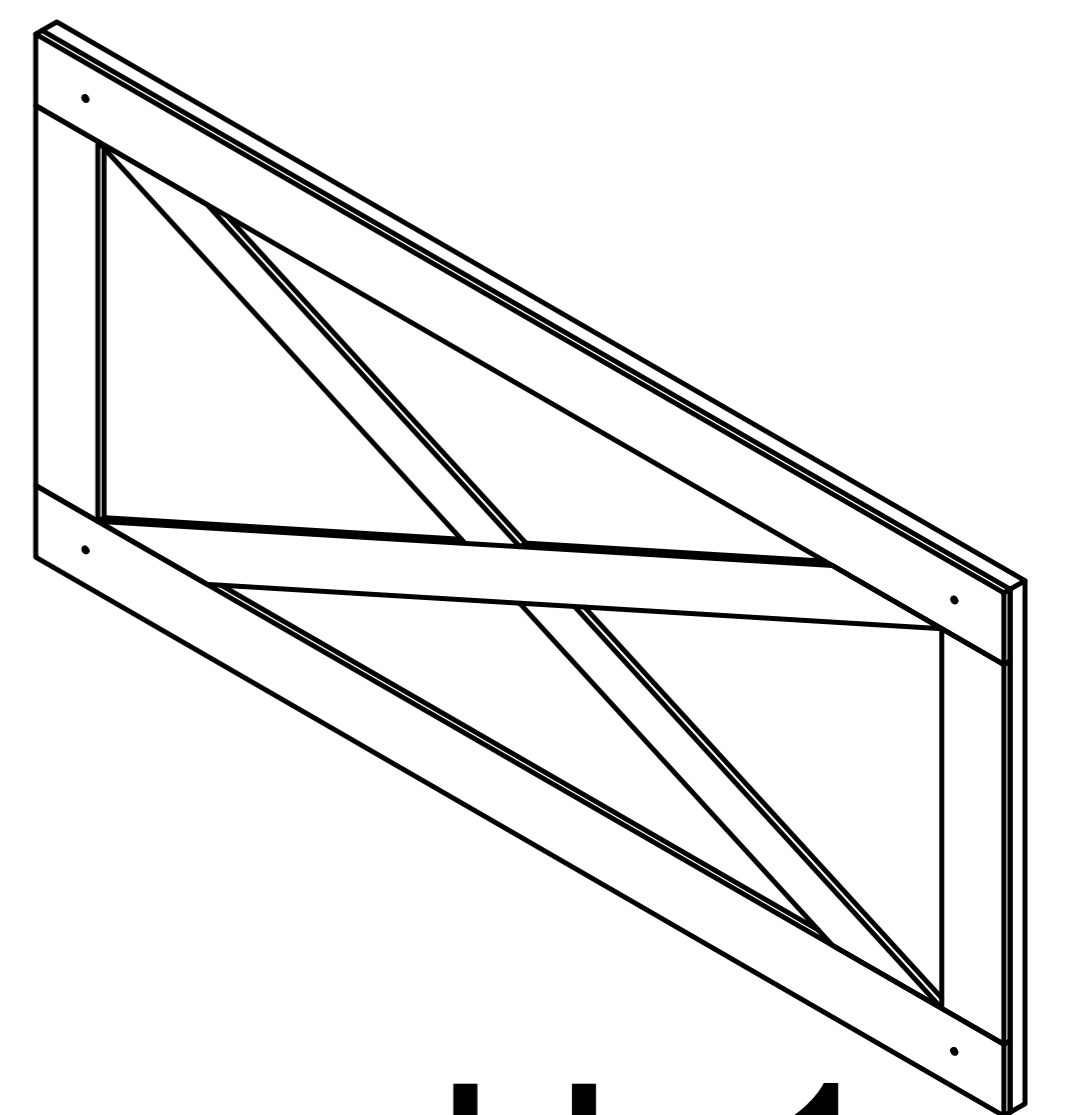

**Hx1**

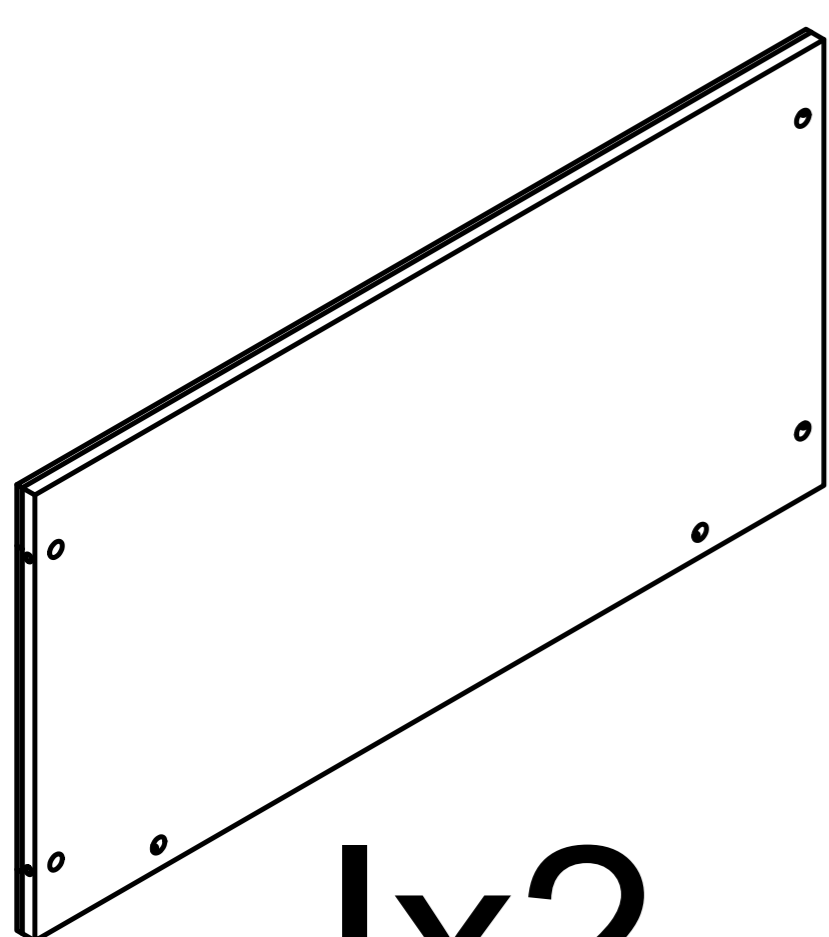

**Ix2**

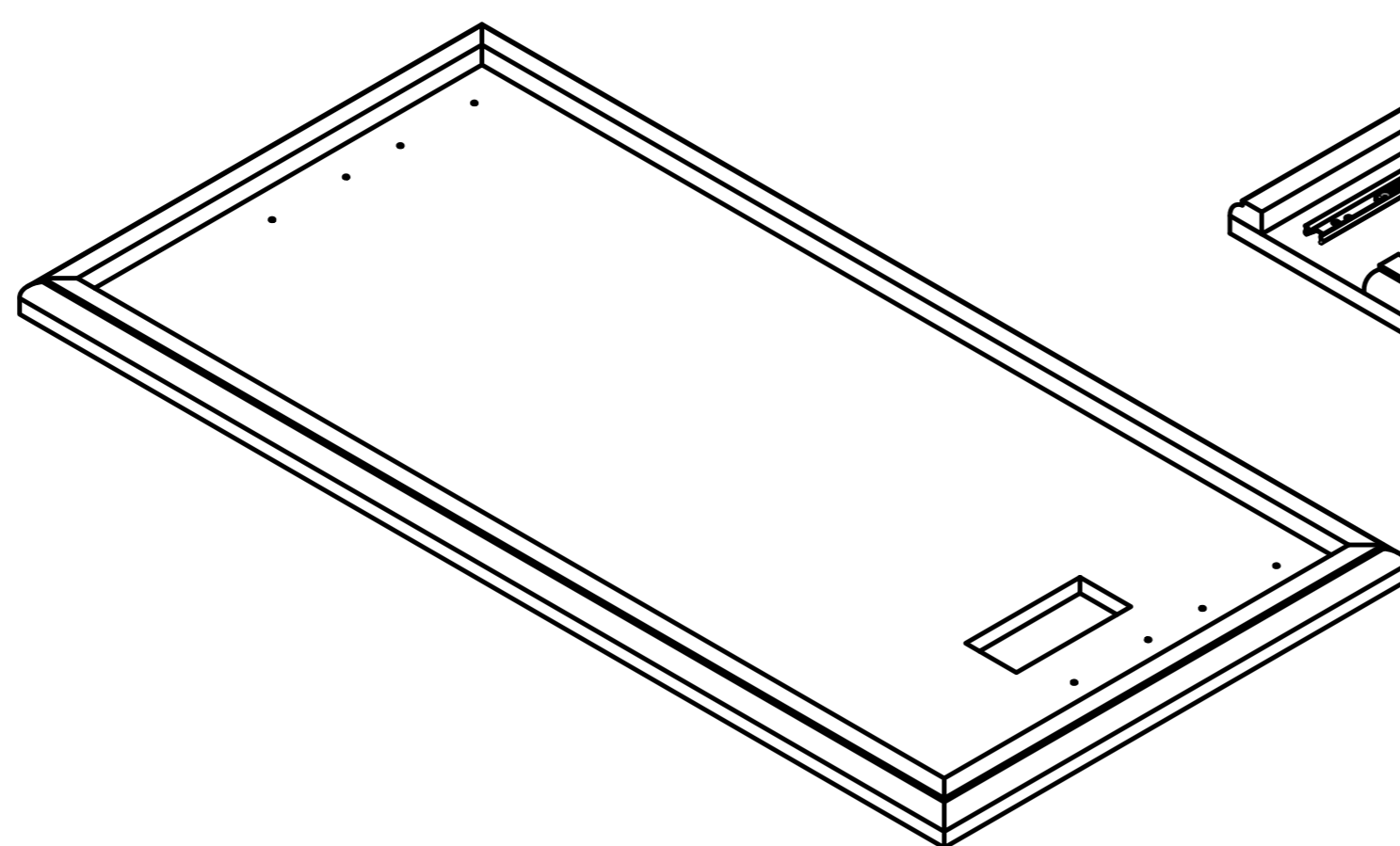

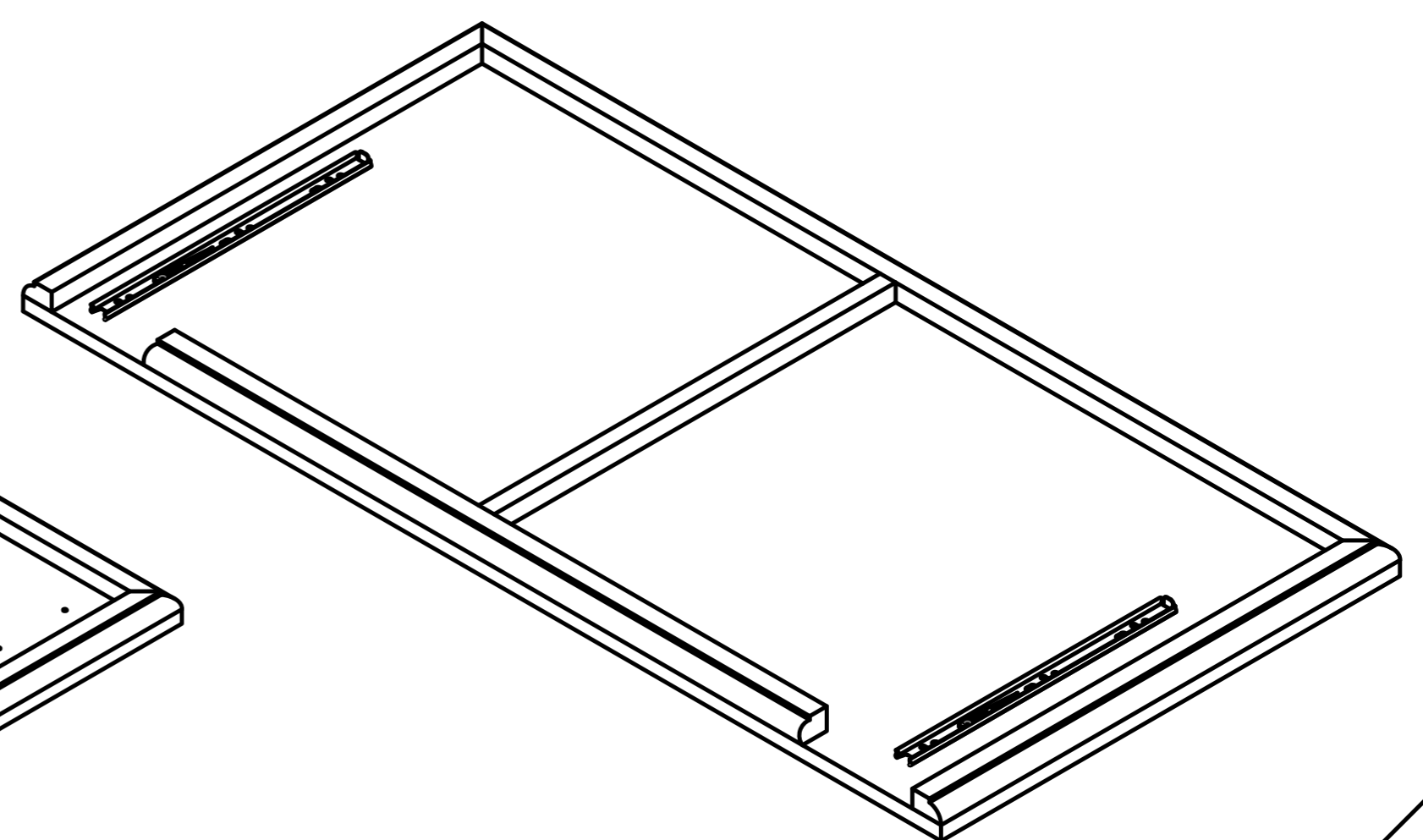

**Jx1**

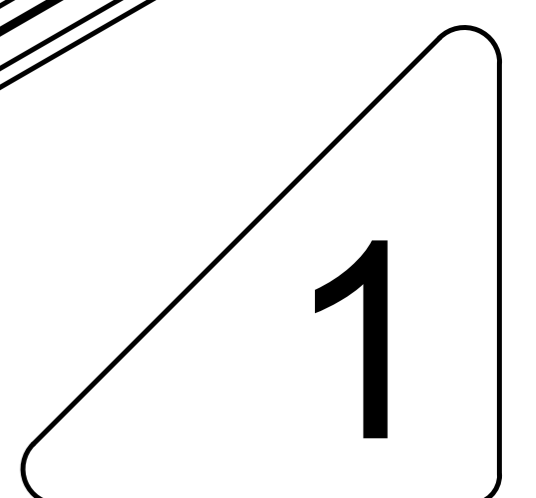

**Kx1**

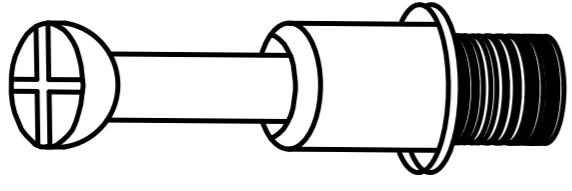
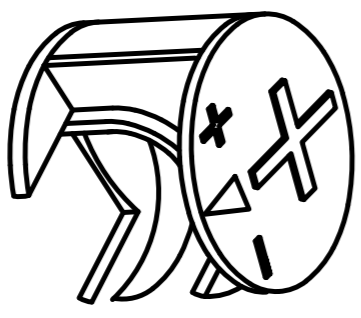

**1**

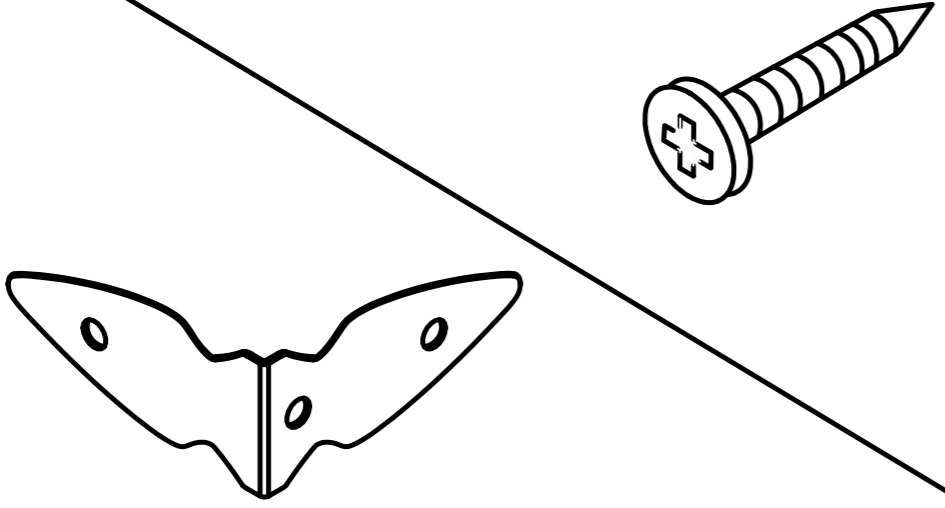
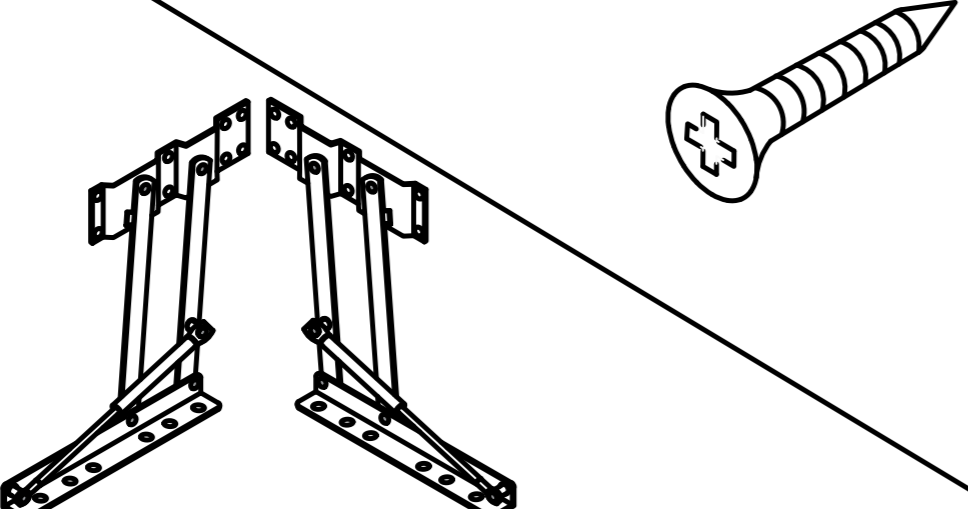
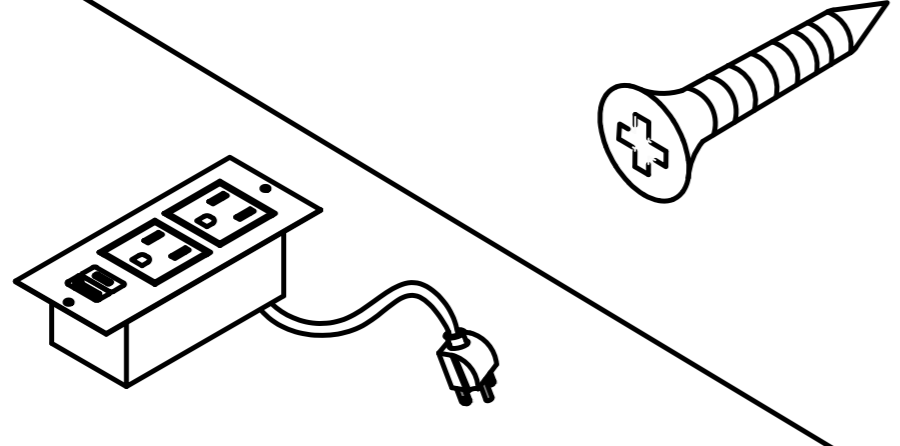
①		Two In One Screw (6x28mm)	46pcs +2pcs
②		Two In One Nut (10x12mm)	46pcs +2pcs
③		Mute pad	15pcs +1pcs
④		Corner Connector & Screw (27x60mm) (3x12mm)	24pcs +2pcs 8pcs
⑤		Rebound Device & Screw (4x12mm)	16pcs +4pcs 2pcs
⑥		Power Socket & Screw (3x10mm)	2pcs +1pcs 1pcs

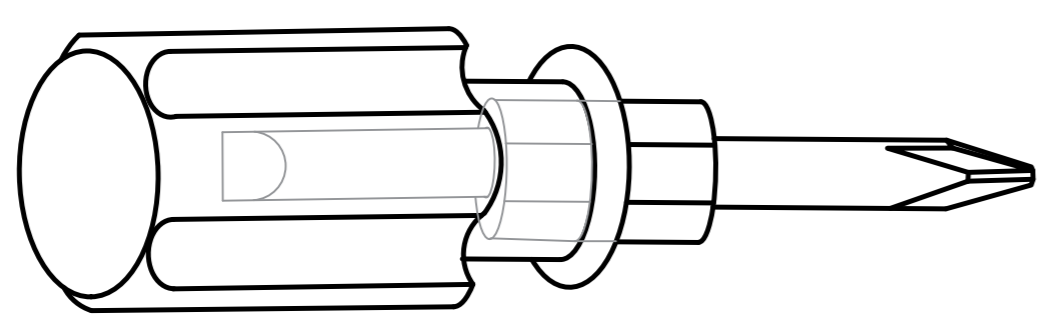

1pcs

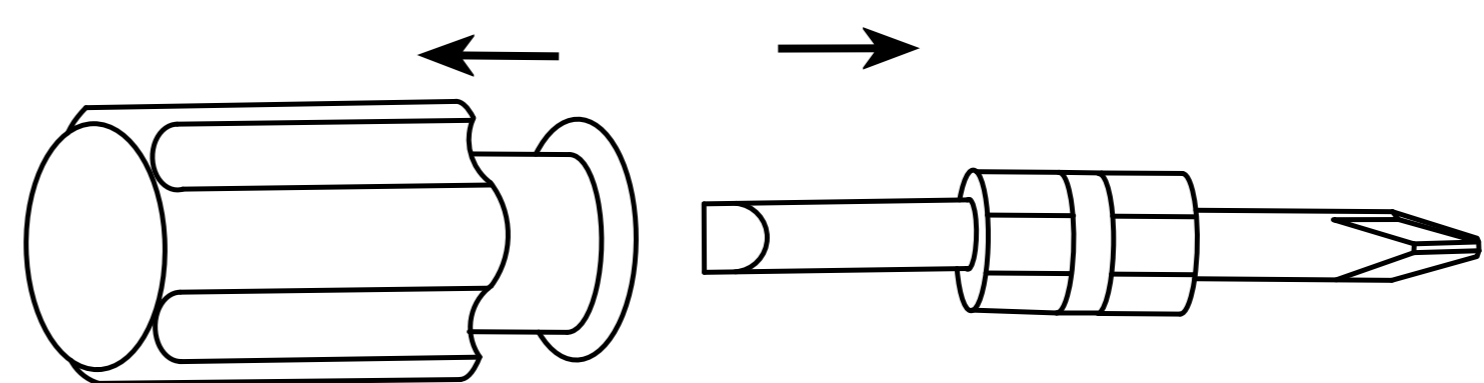

Double-head screwdriver, use as required

# Product structure decomposition

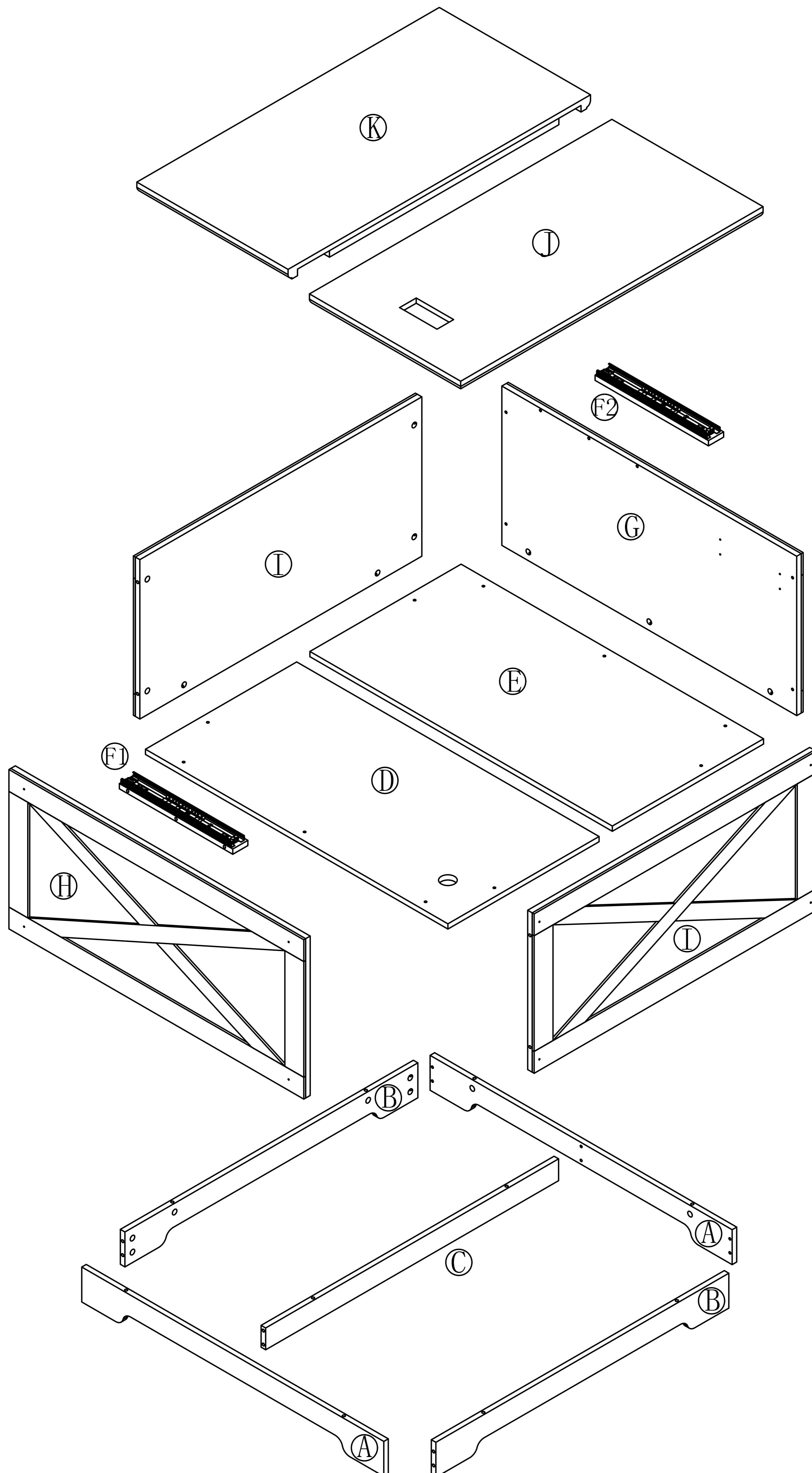

# Use parts ① and ②

Step 1

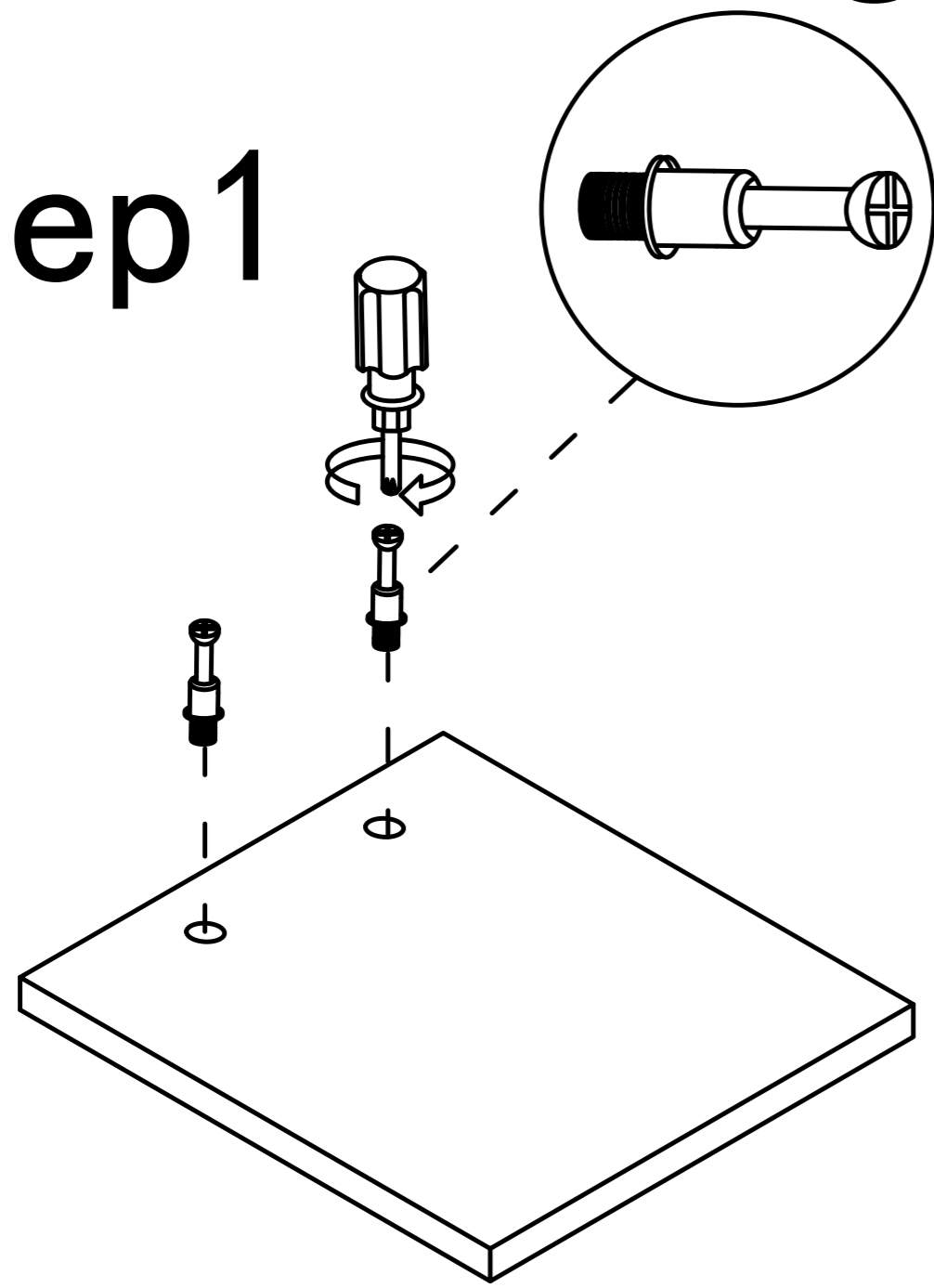

Step 2

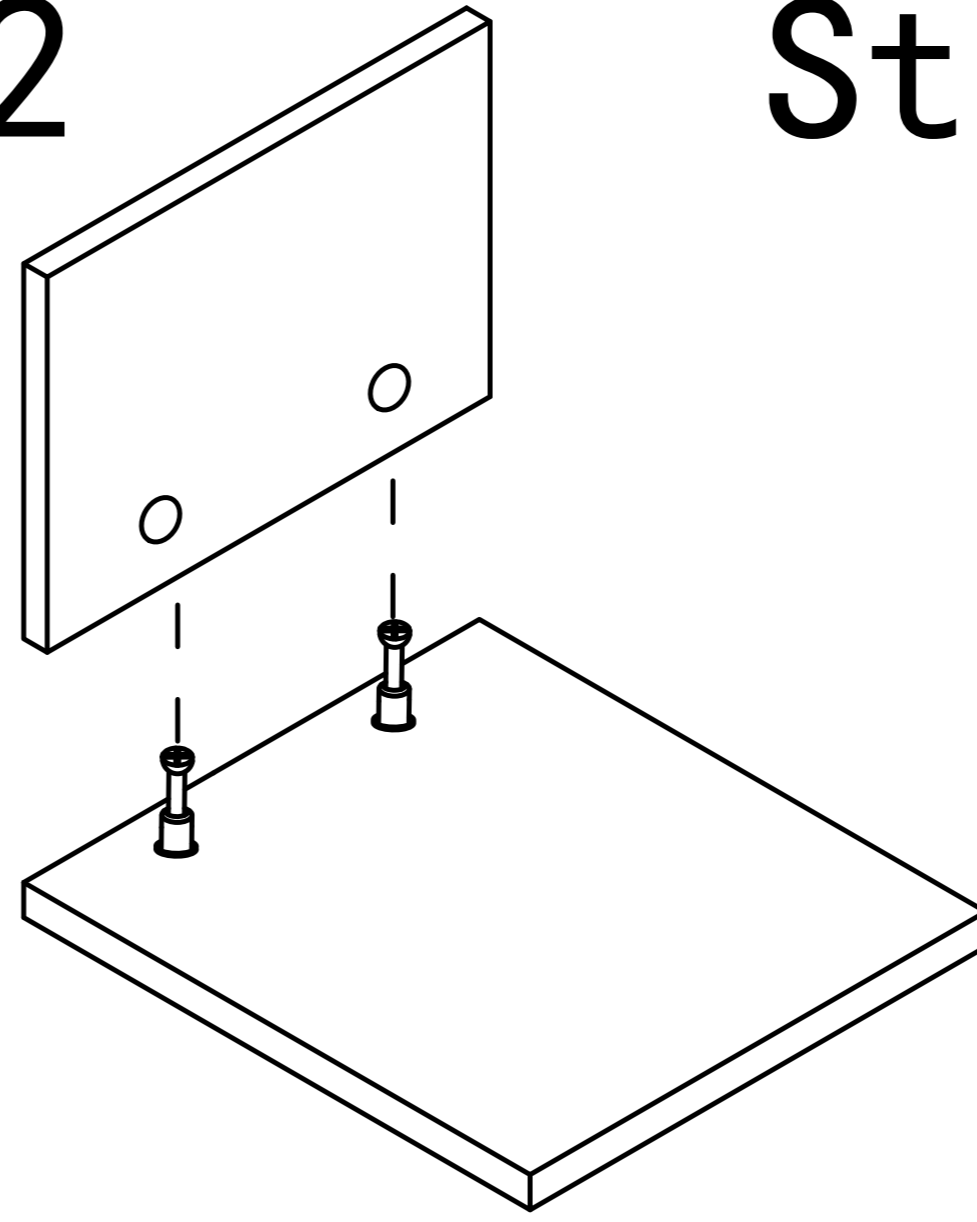

Step 3

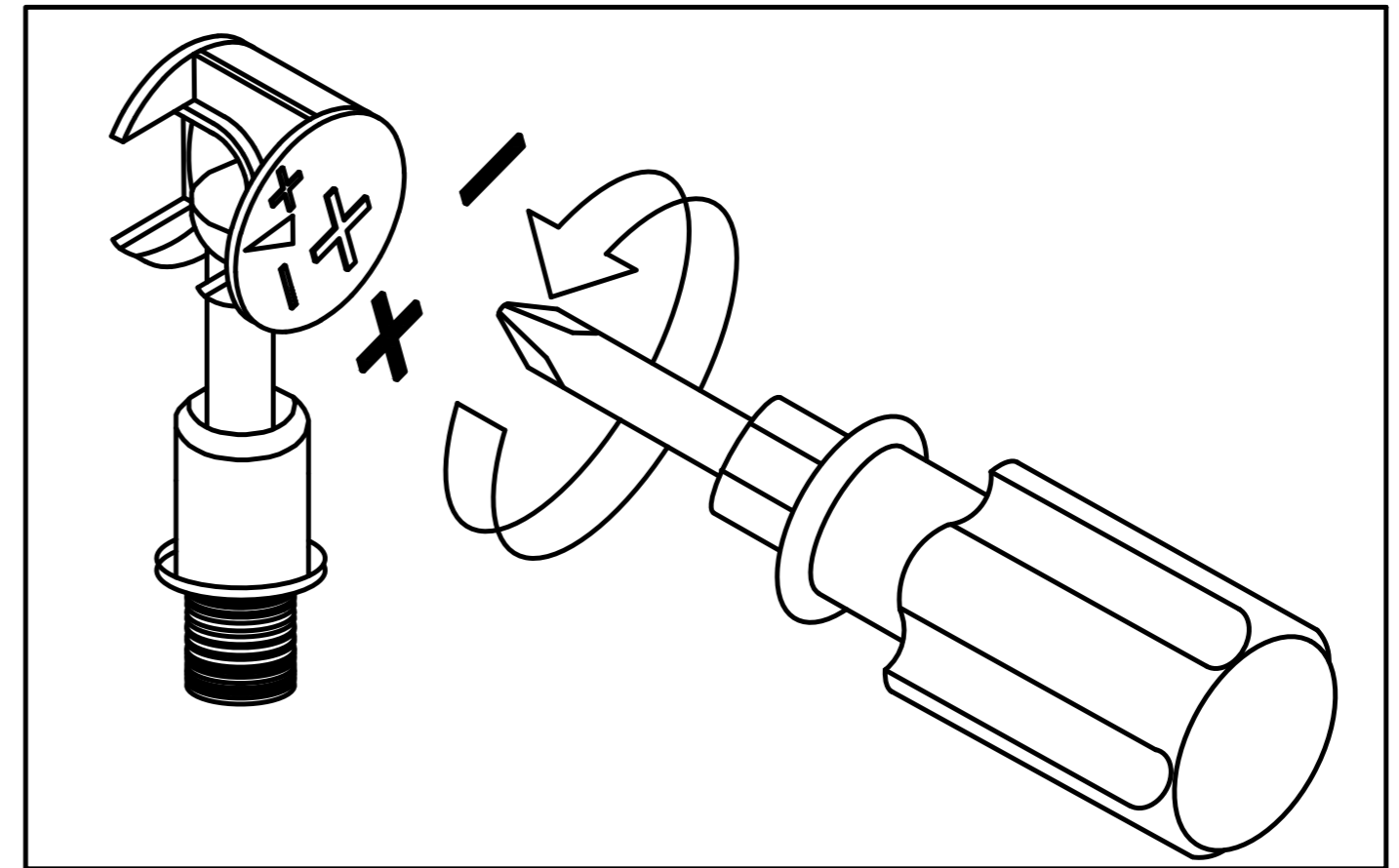
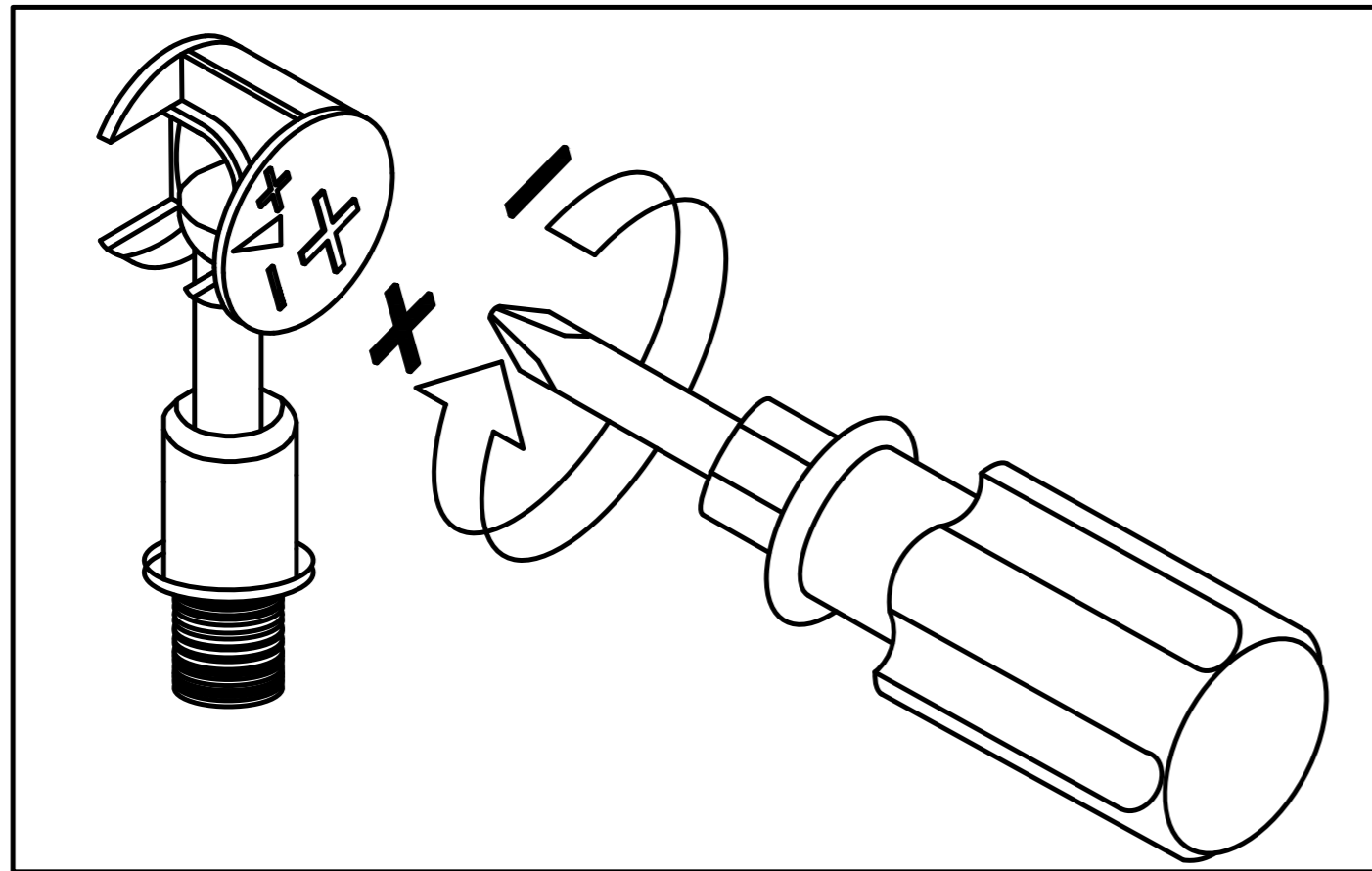
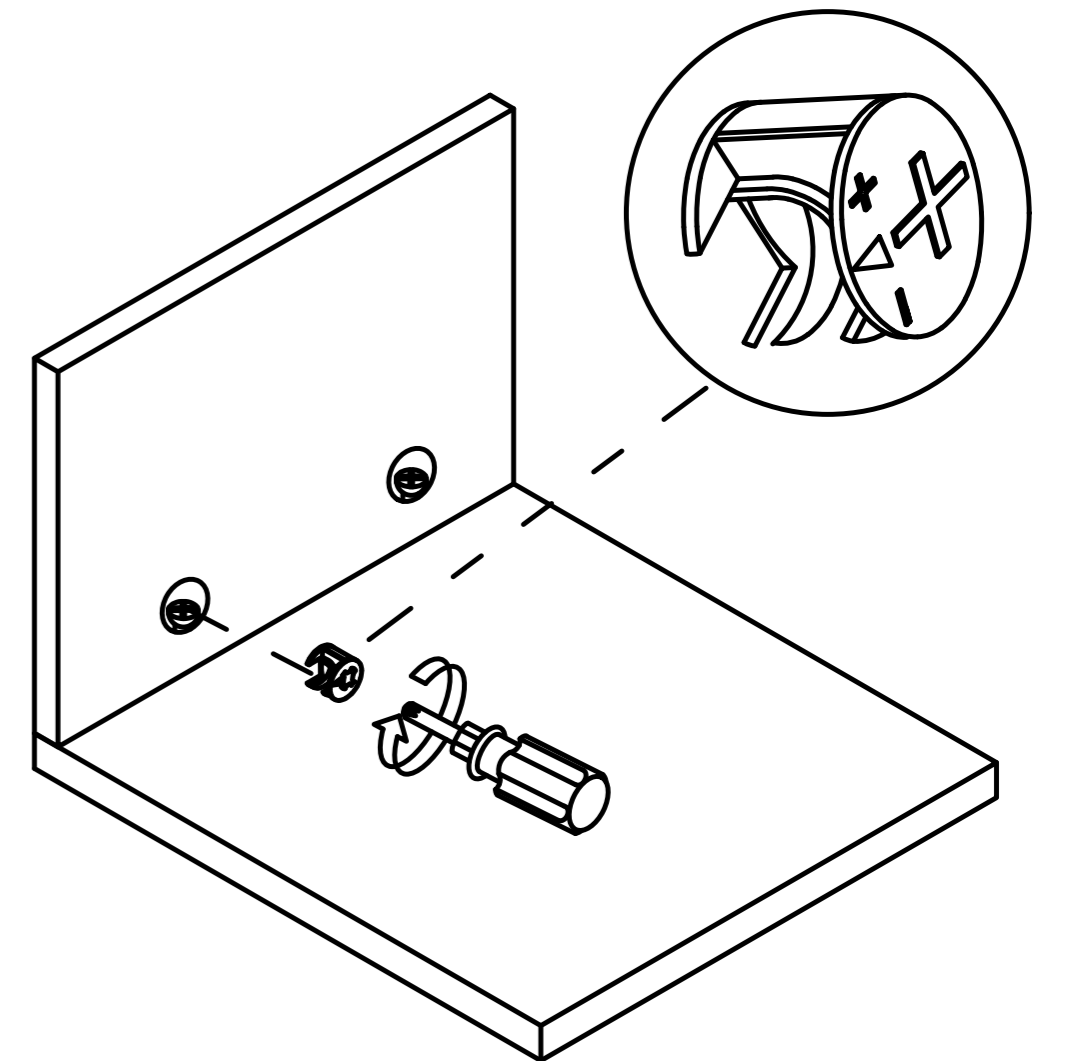

Use a screwdriver to lock in the direction of the "+" sign

Disassemble along the direction of "-" sign

Step 1

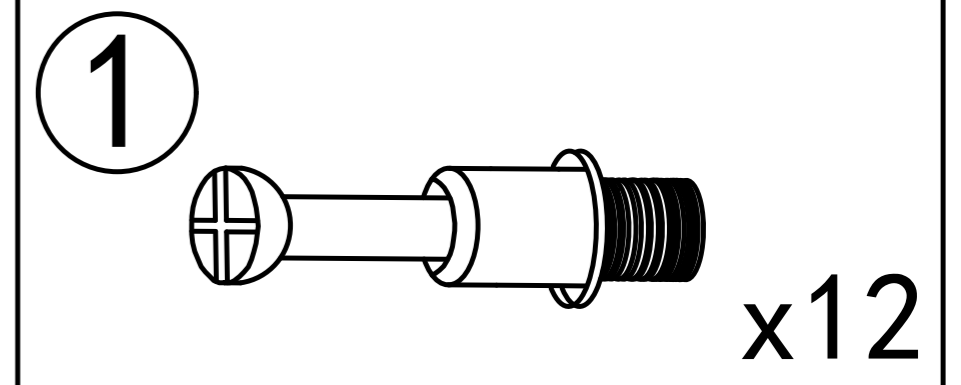
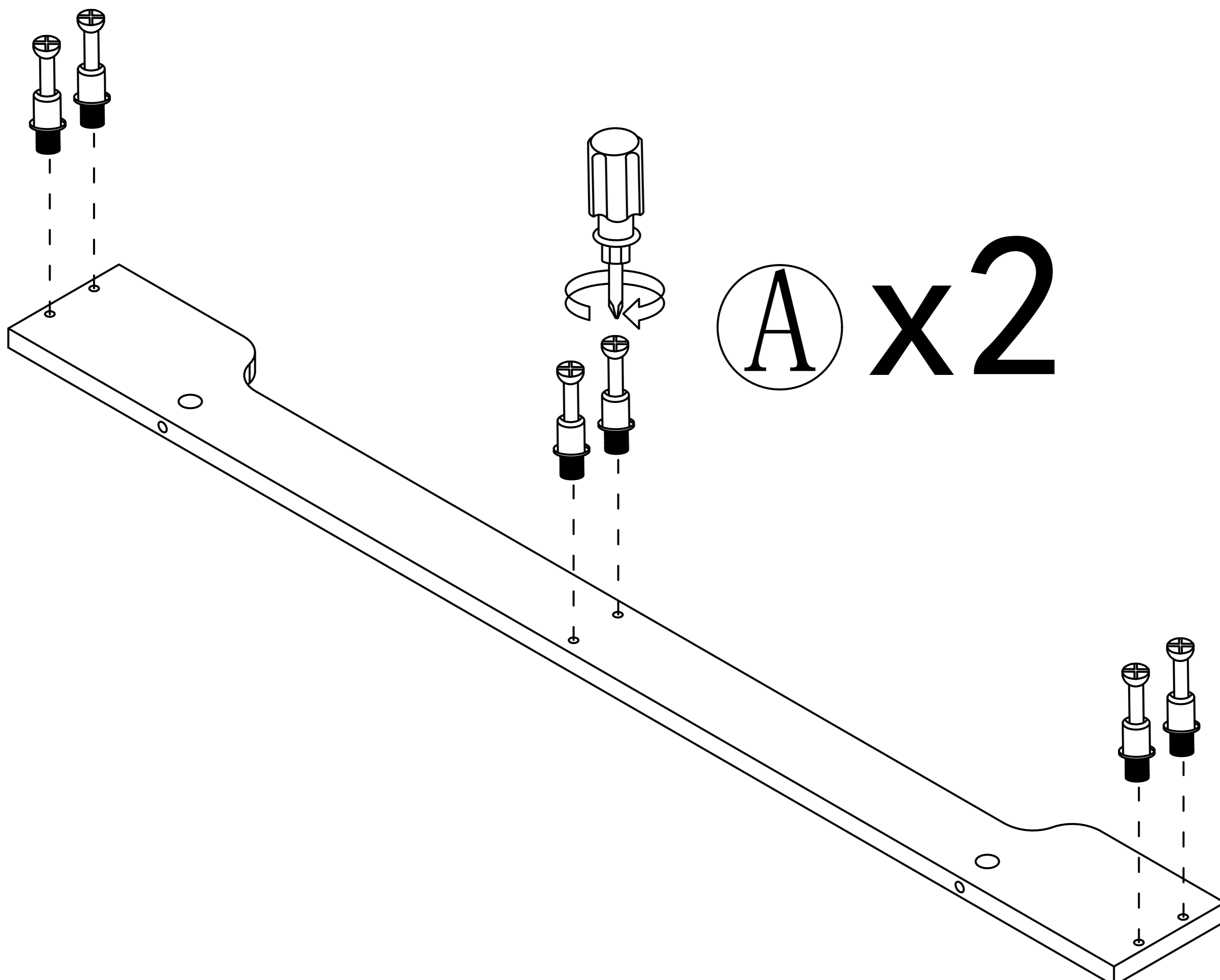

Ⓐ x2

4

Step 2

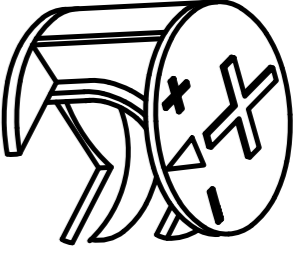
②  x6

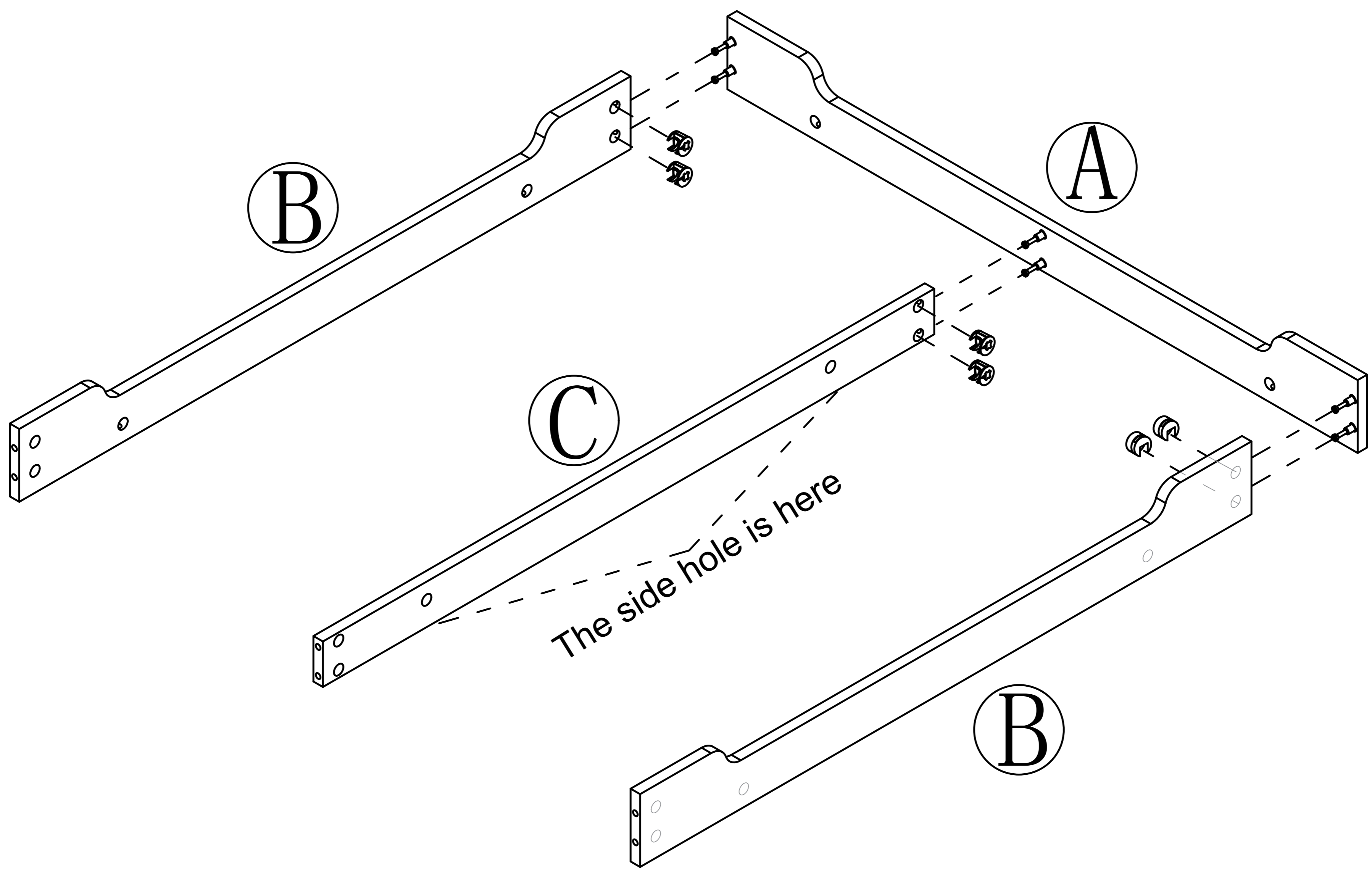

Step 3

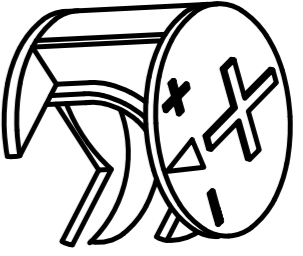
②  x6

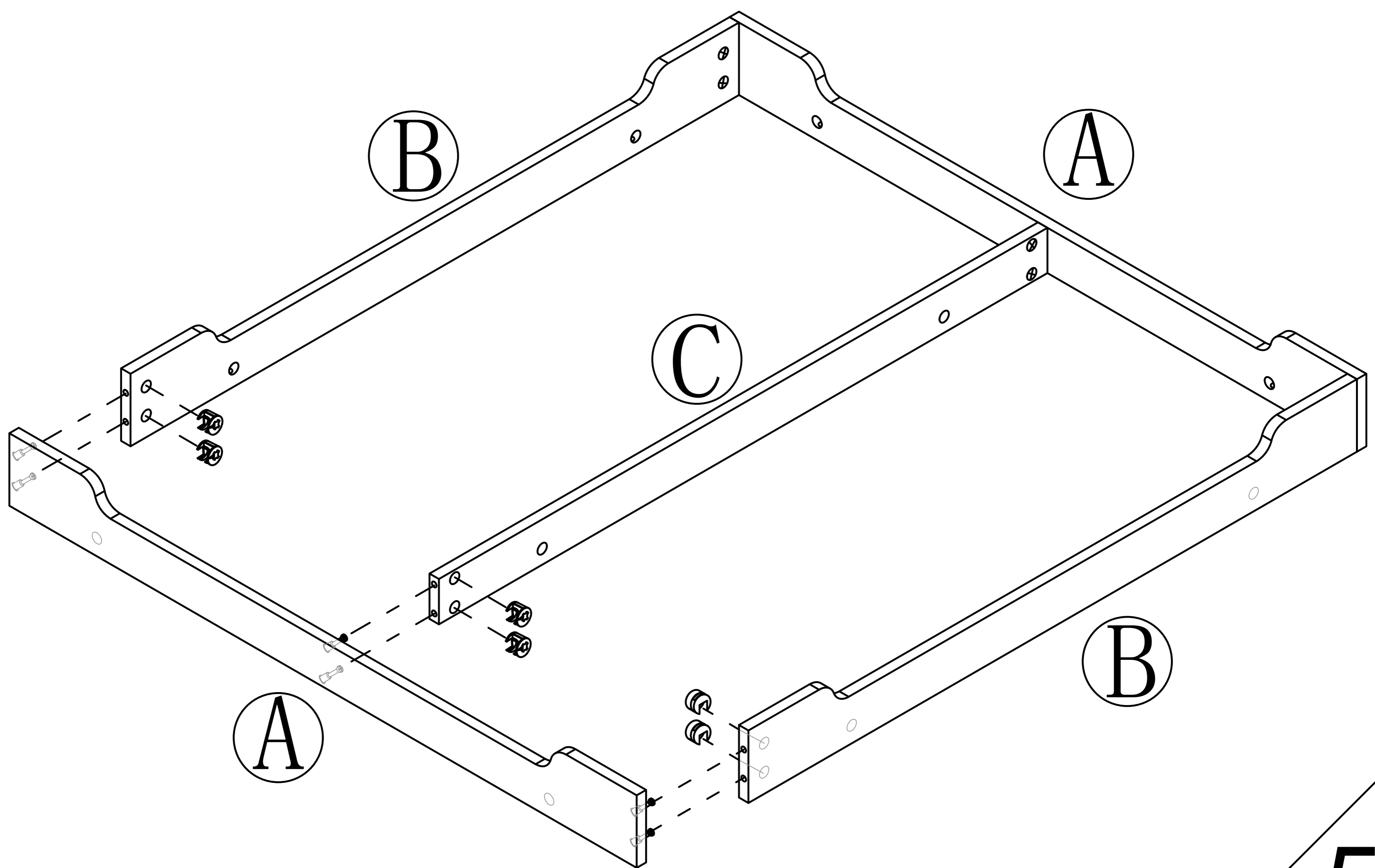

5

Step 4

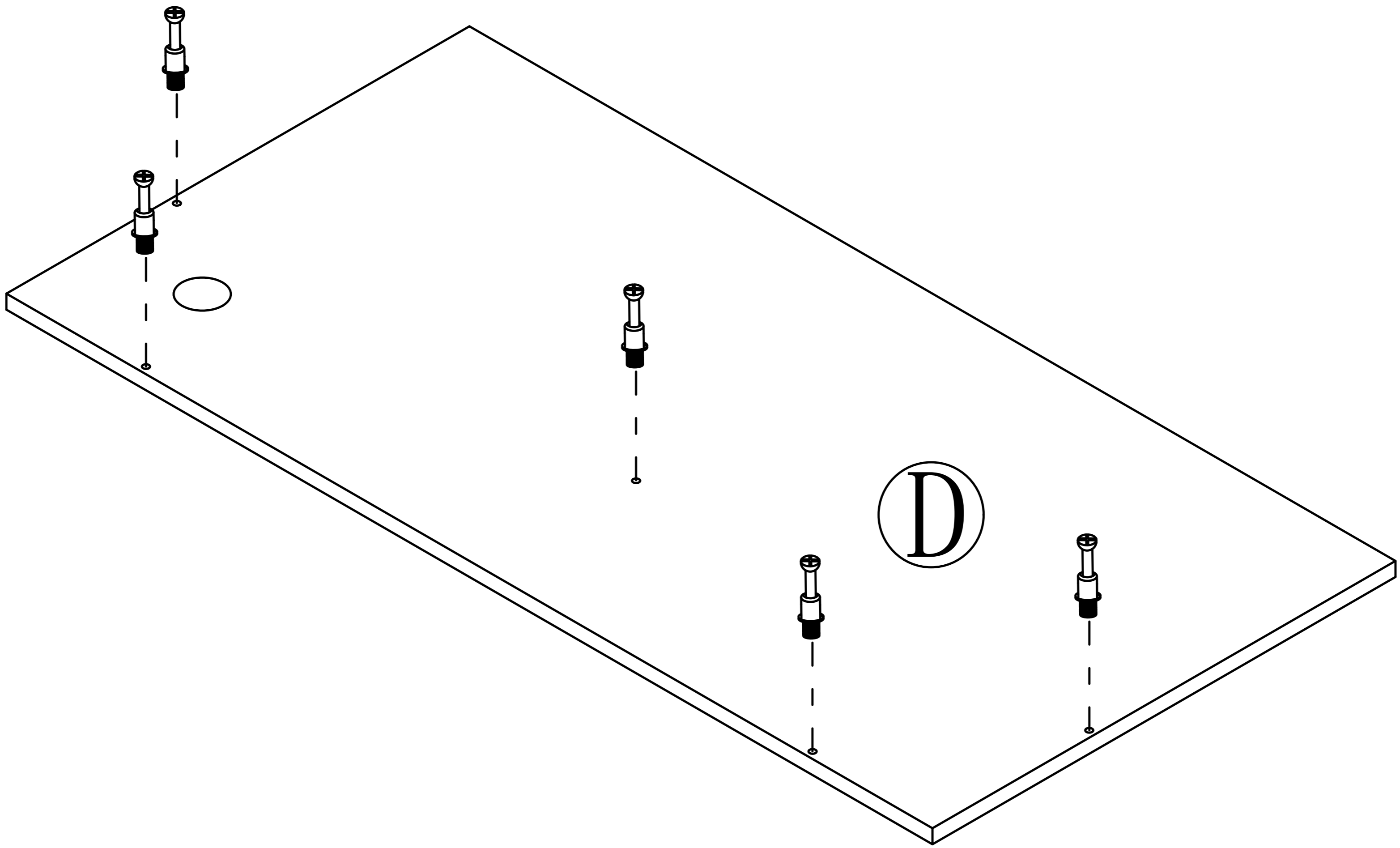
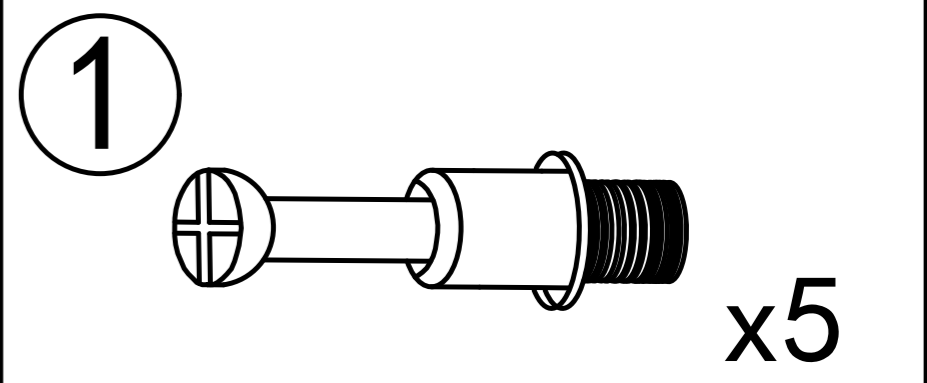

Step 5

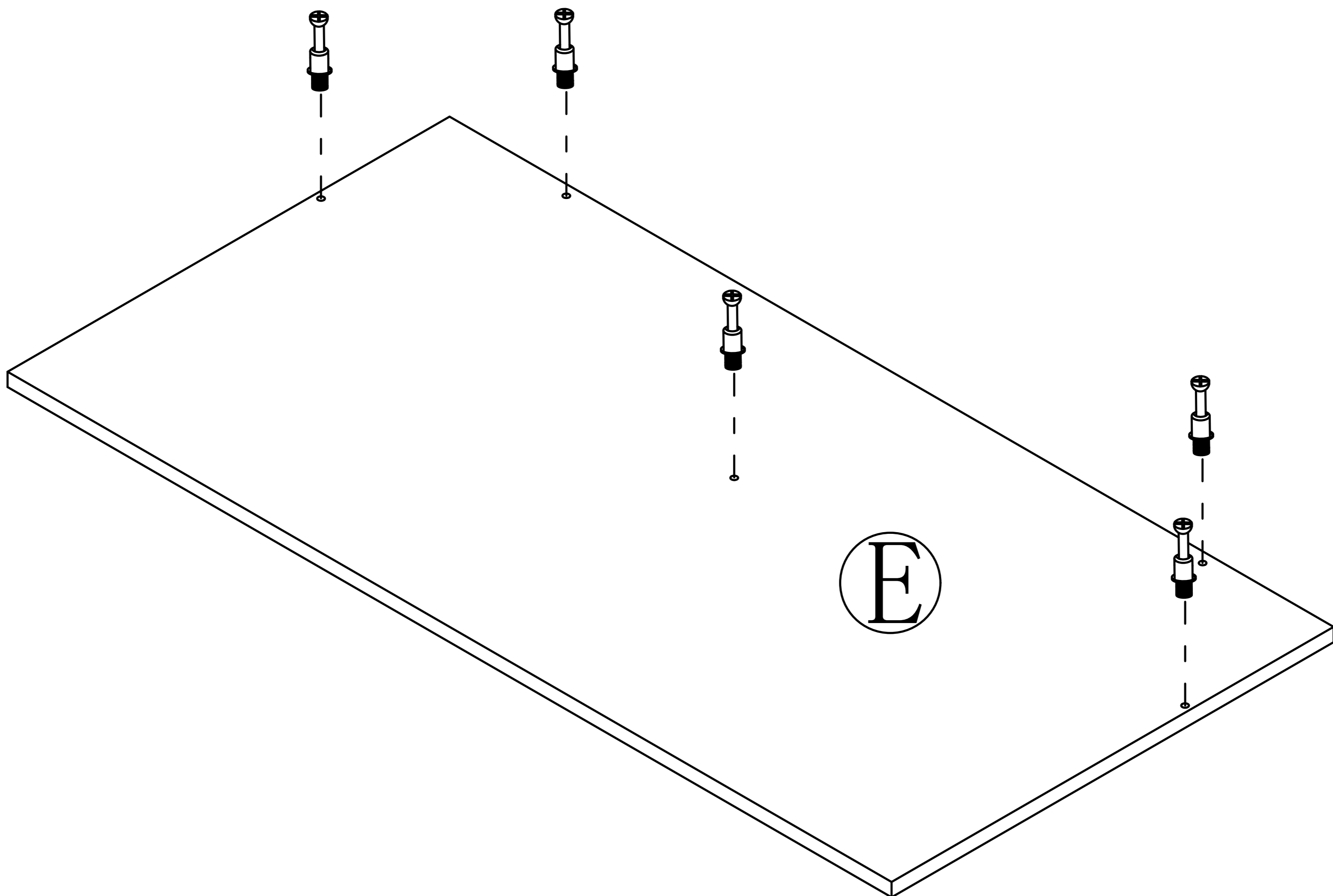
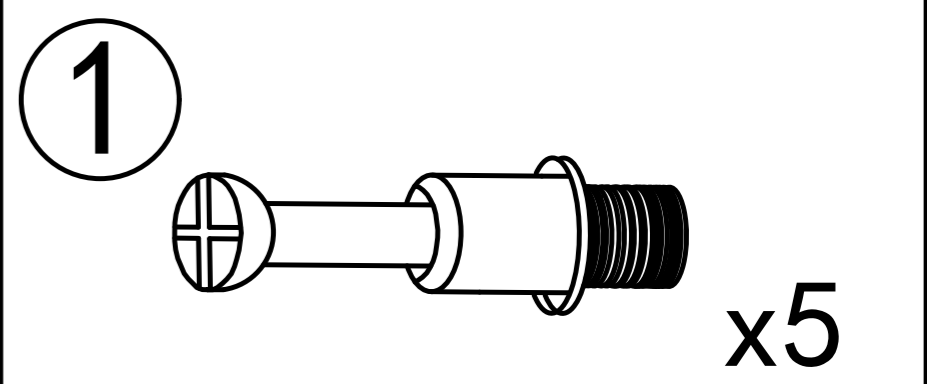

Step 6

2

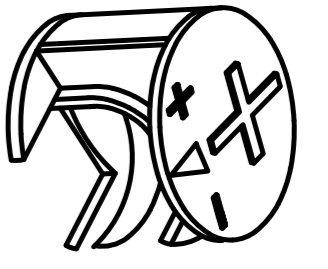

x10

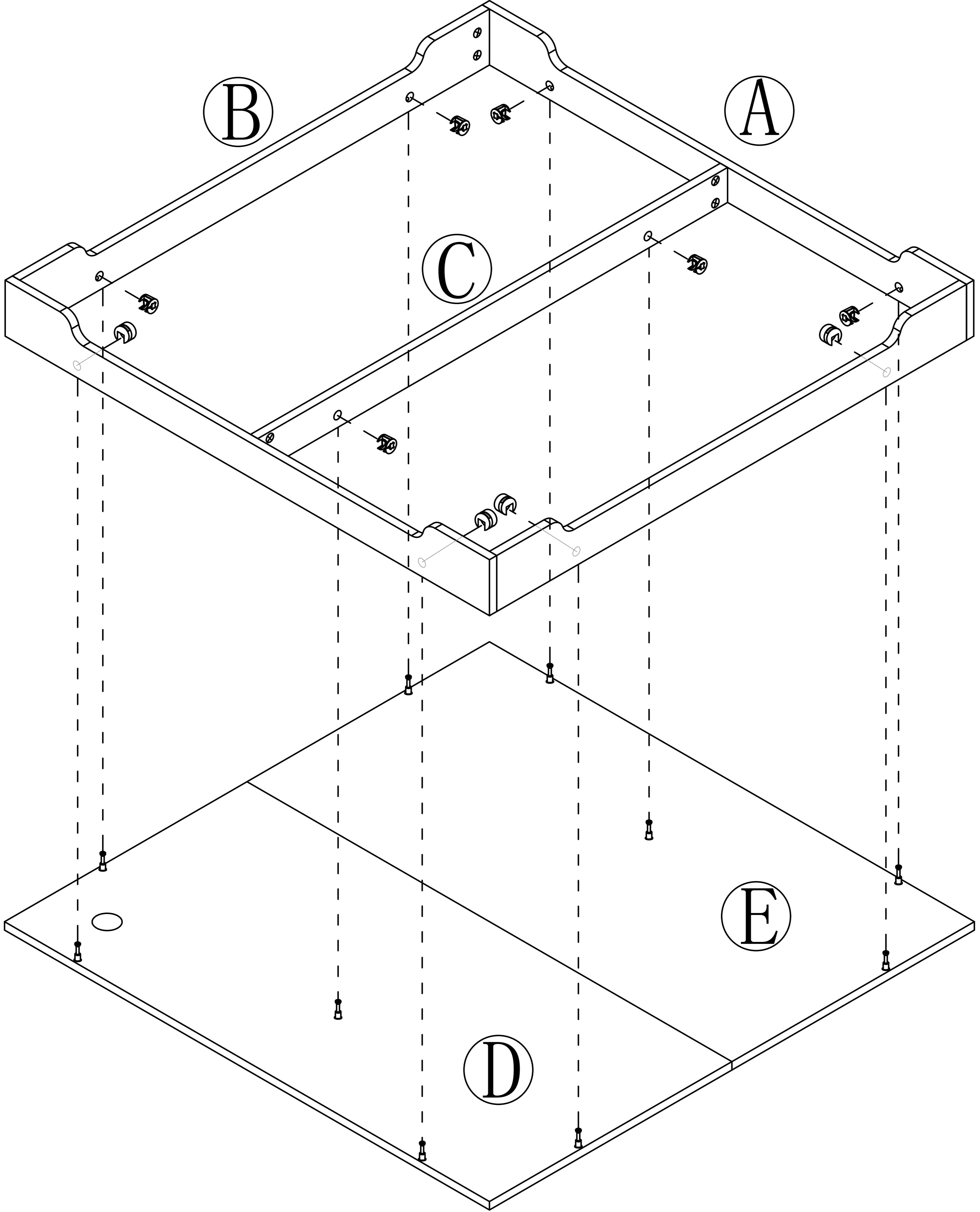

Step 7

3

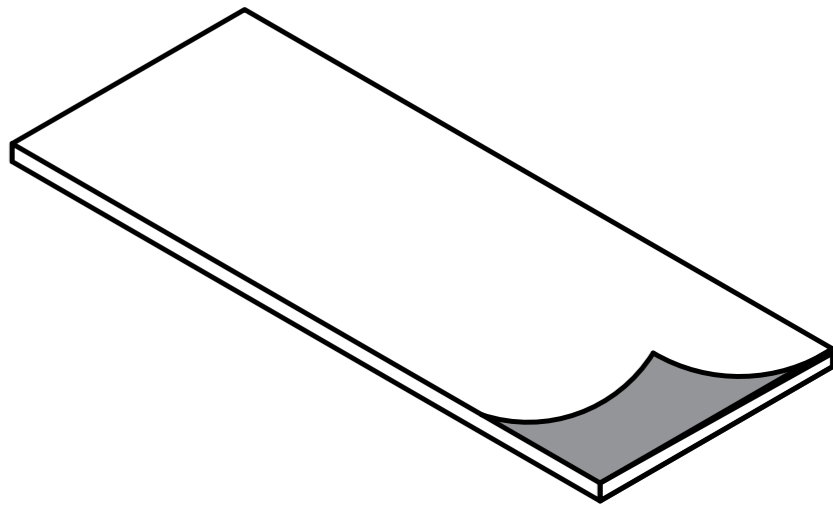

x8

Tear off release paper and stick the black mute pad on the board

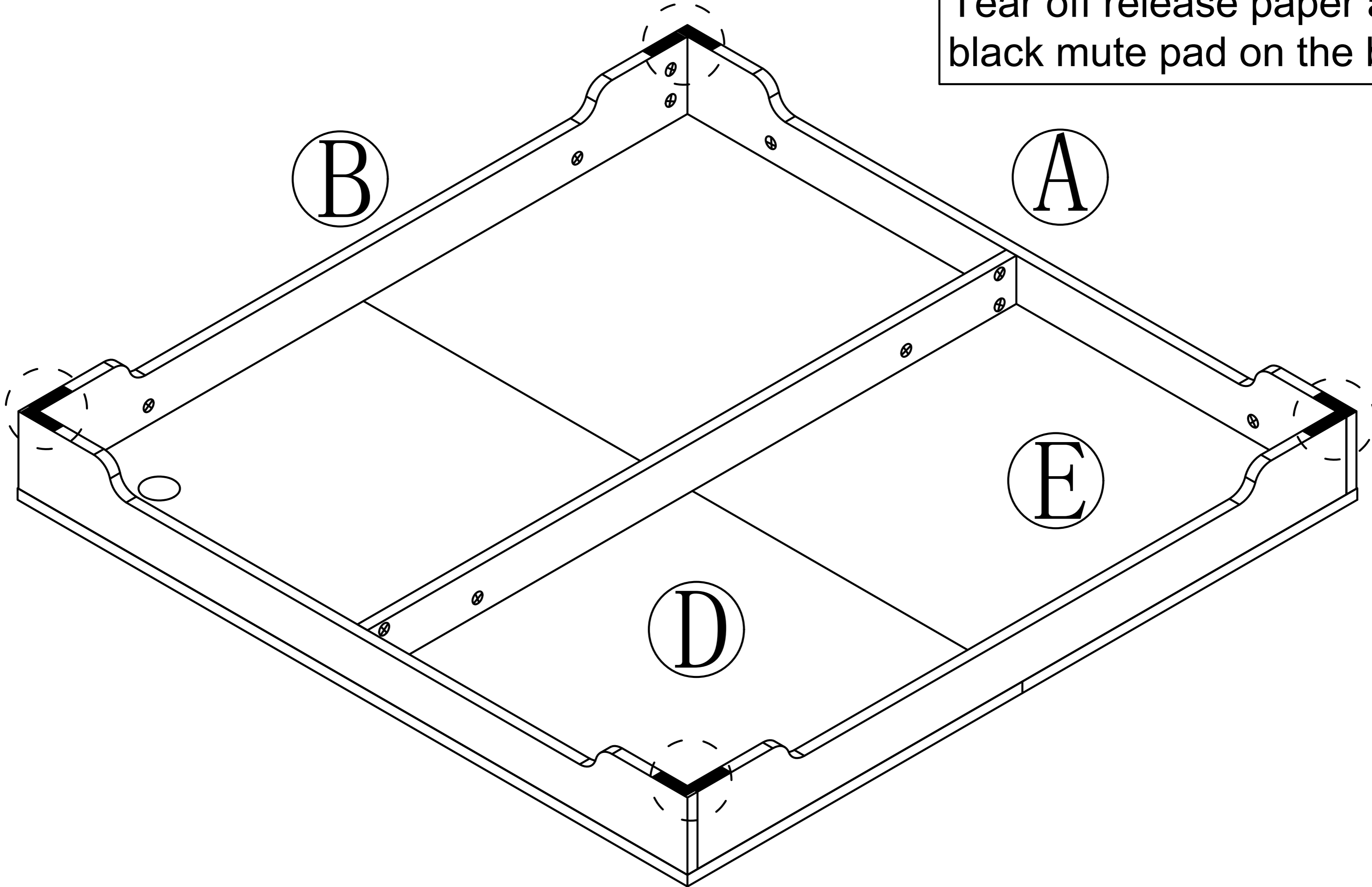

Step 8

1

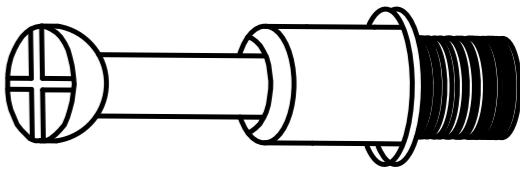

x10

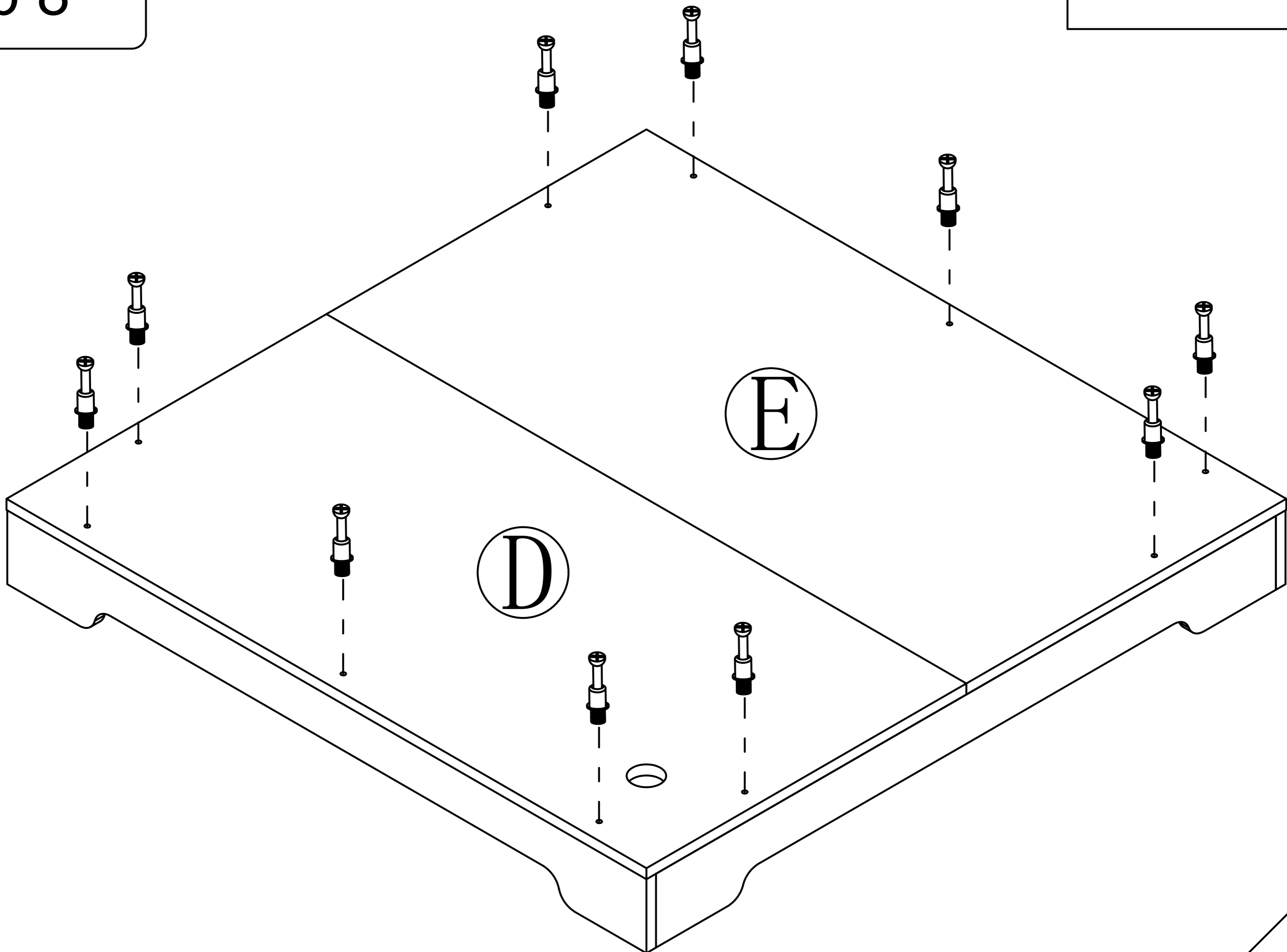

8

Step 9

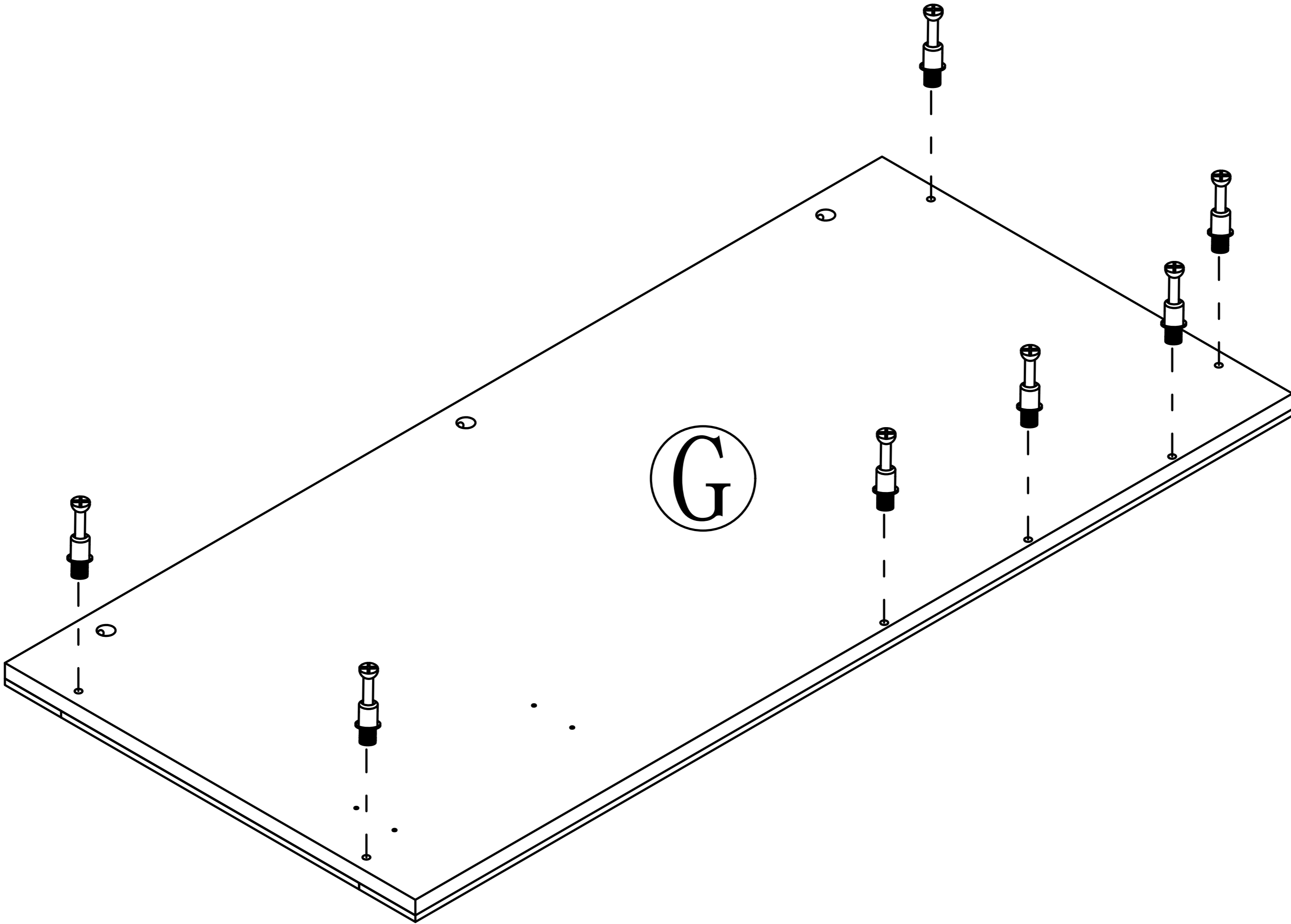
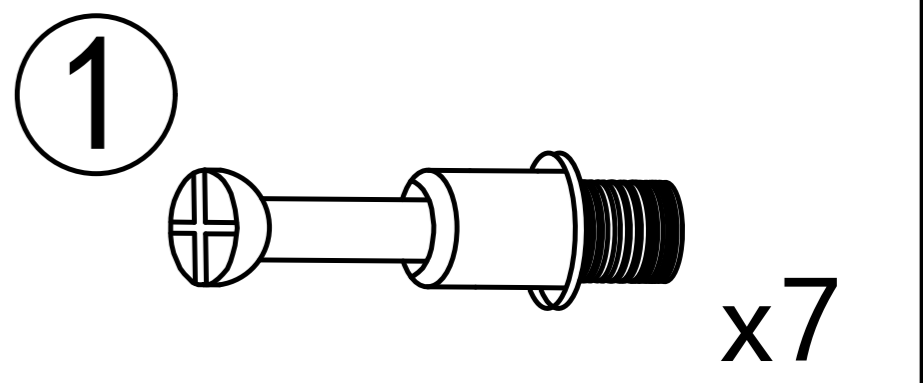

Step 10

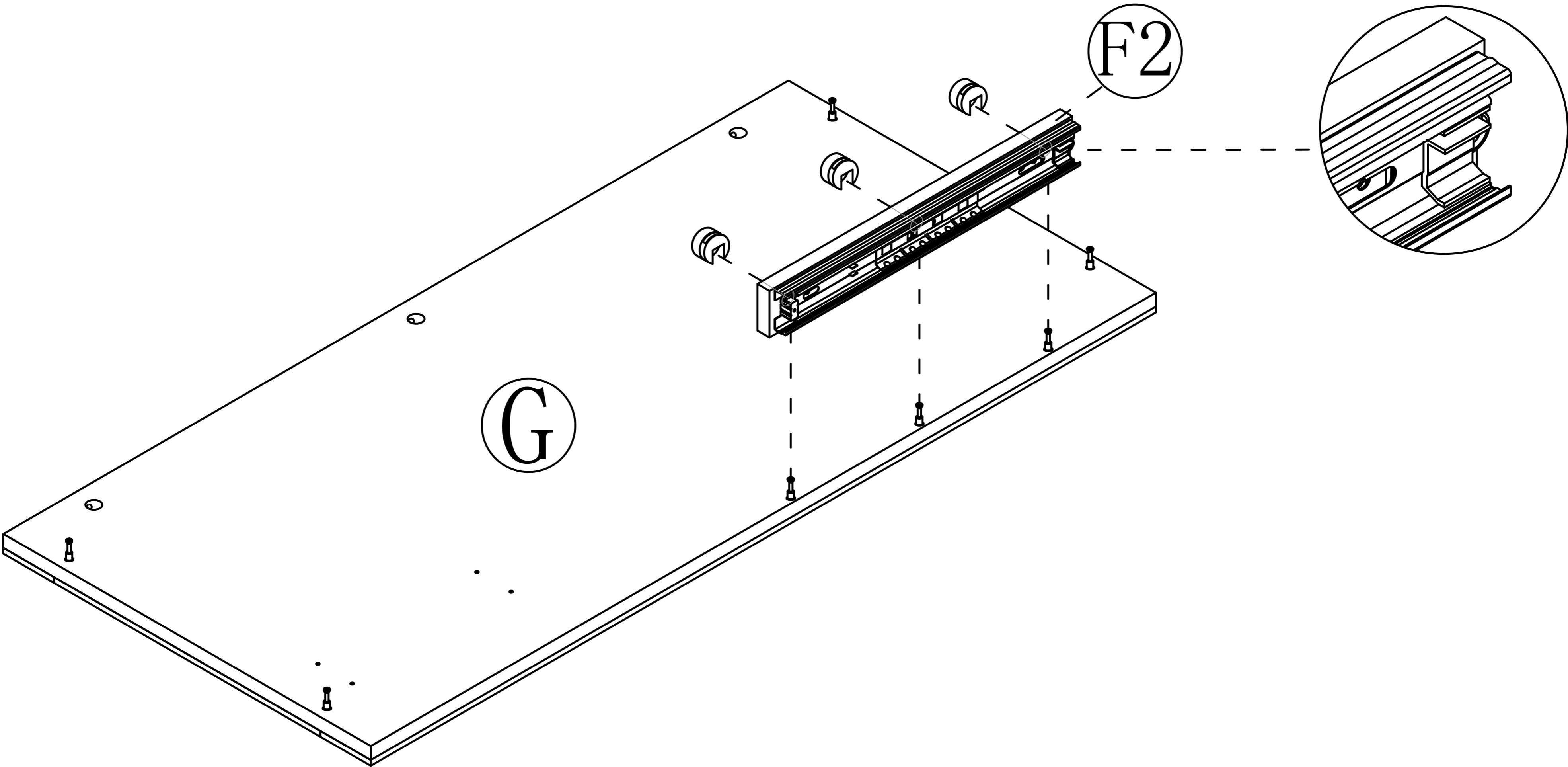
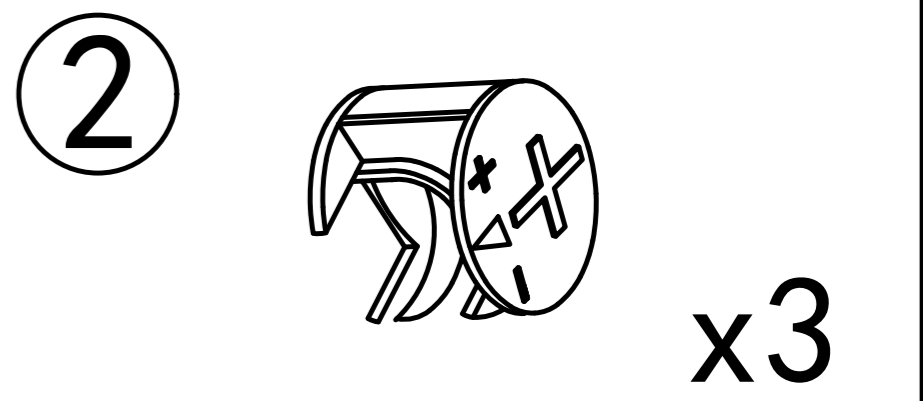

Step 11

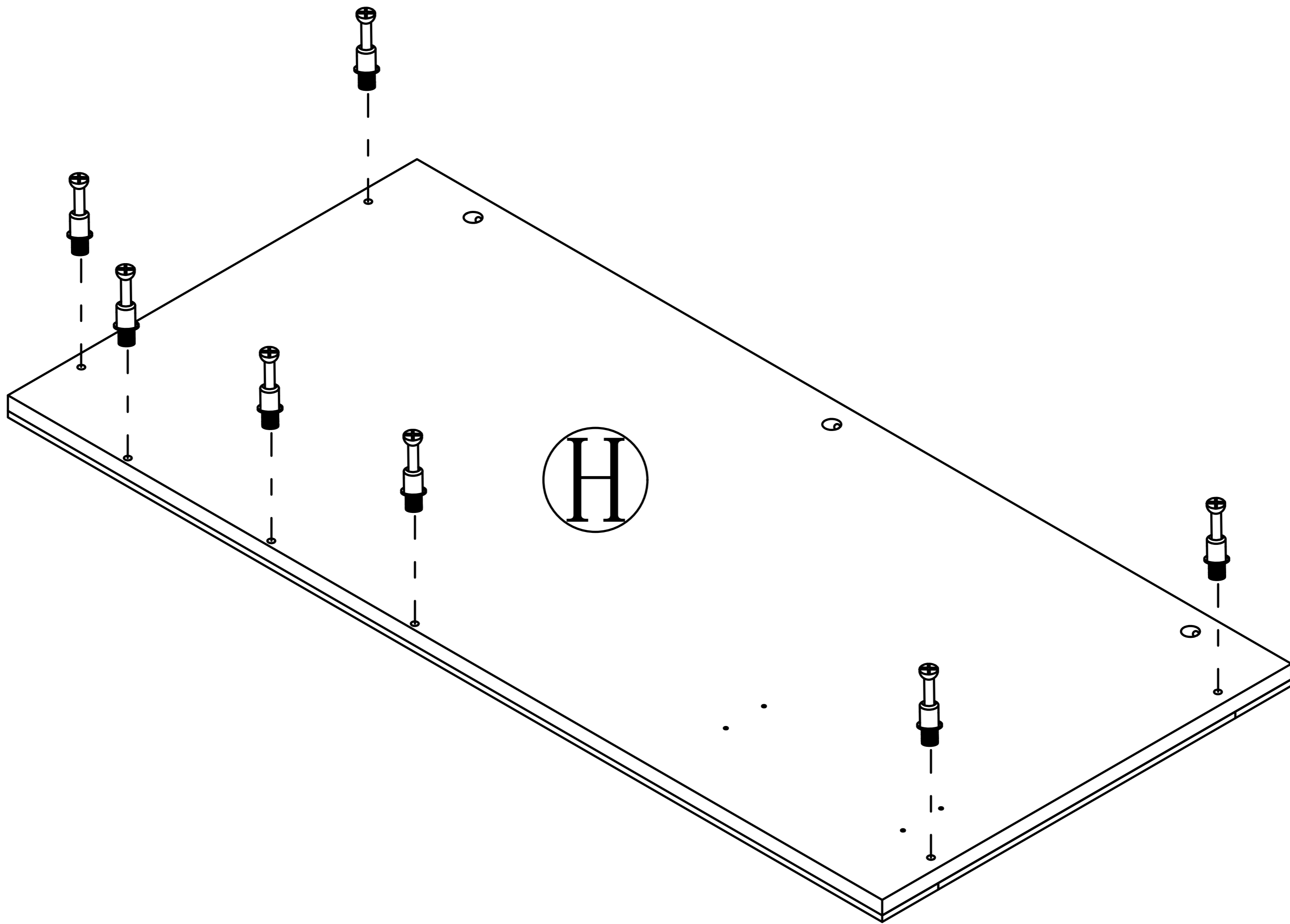
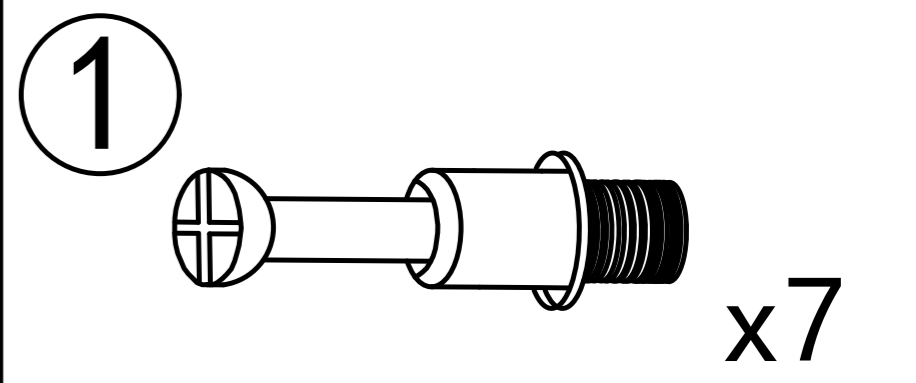

Step 12

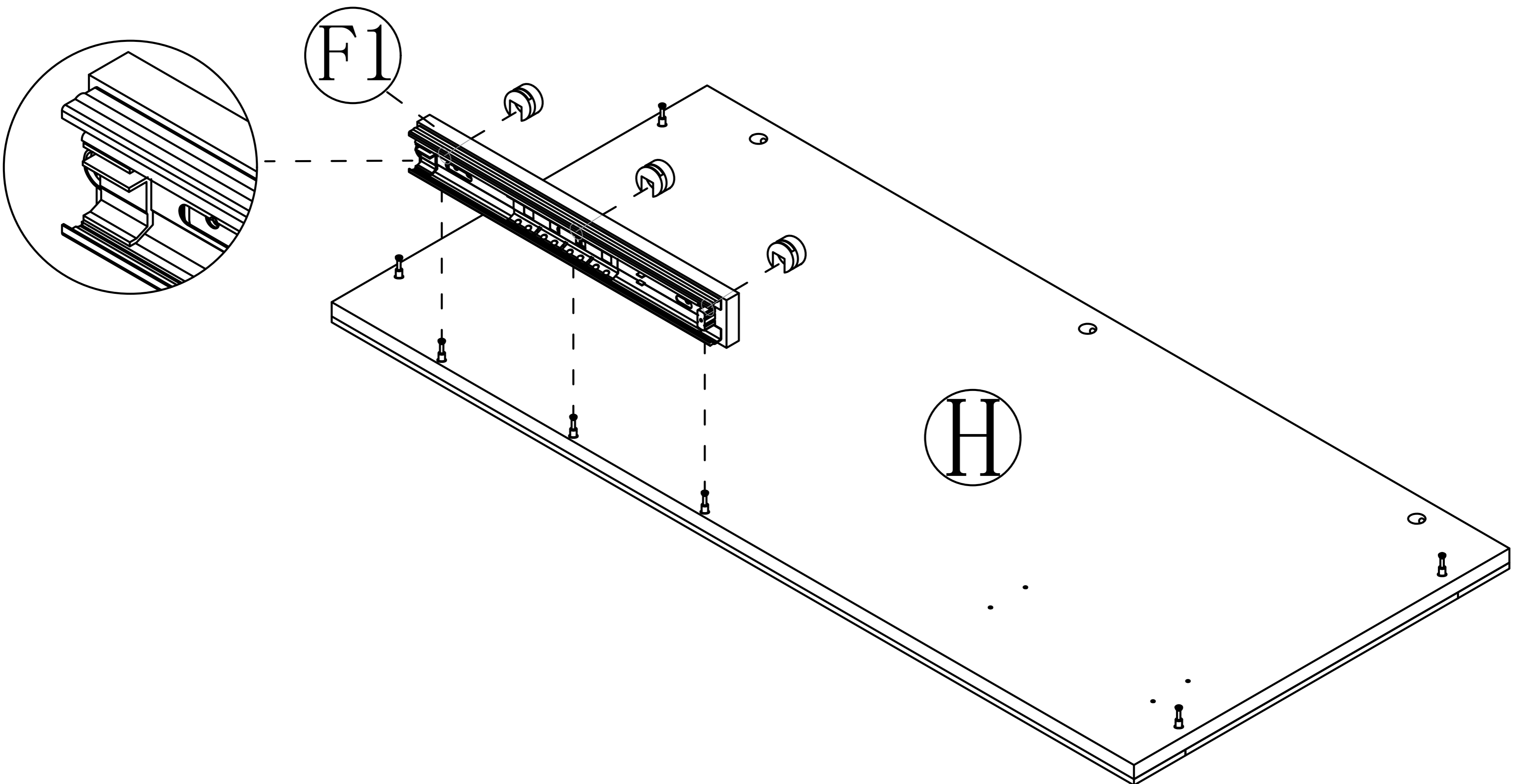
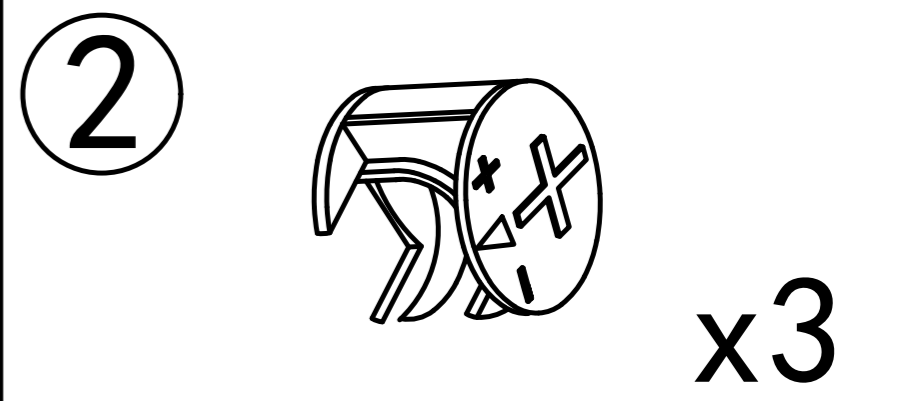

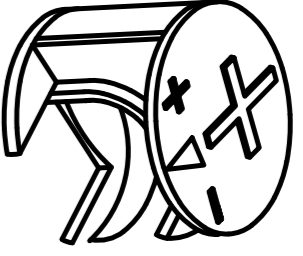

Step 13

2  x8

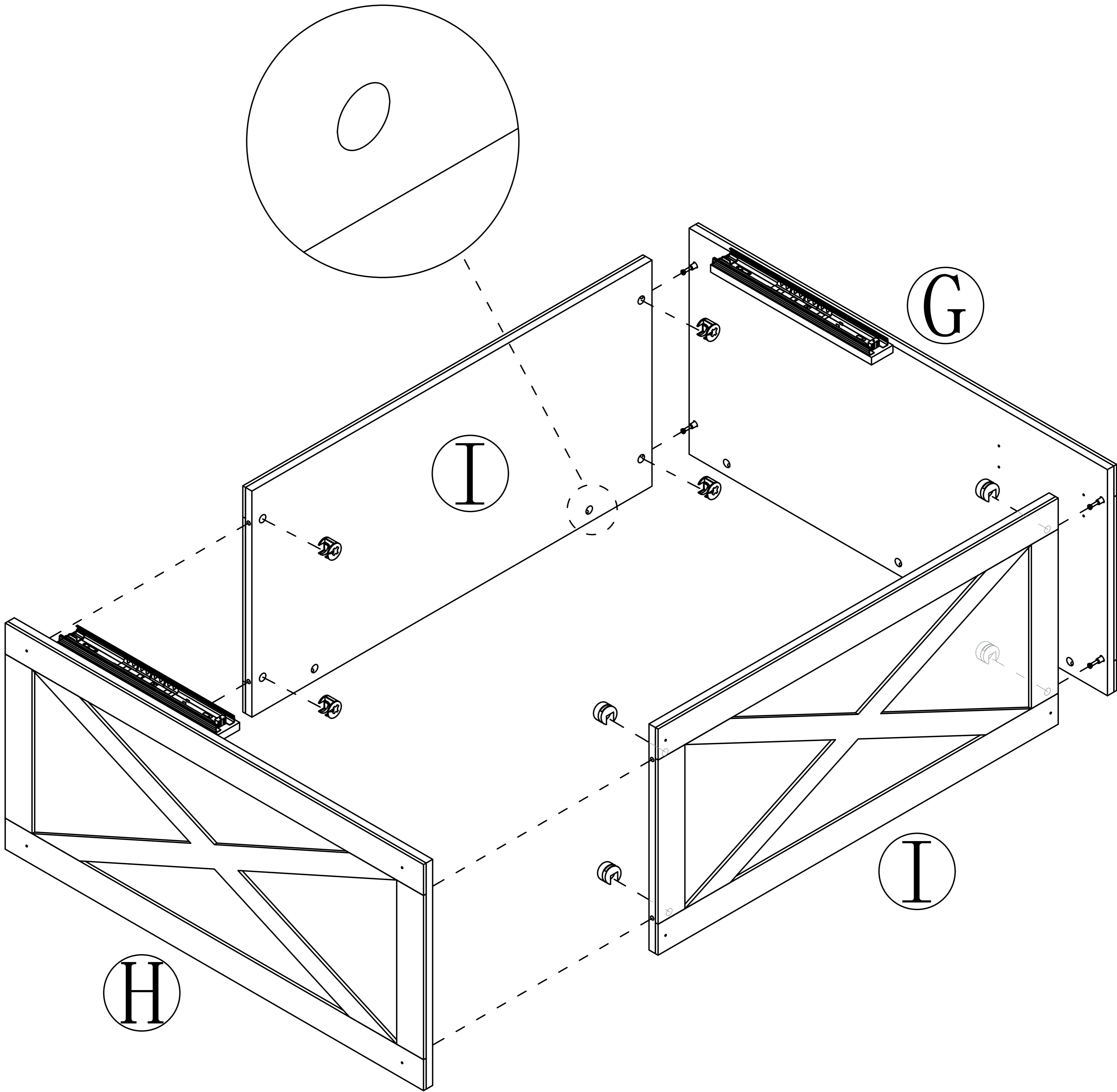
Pay attention to the hole position of the "I"board during installation

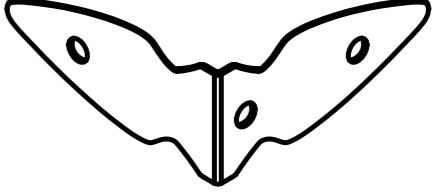

Step 14

4  x8  x24

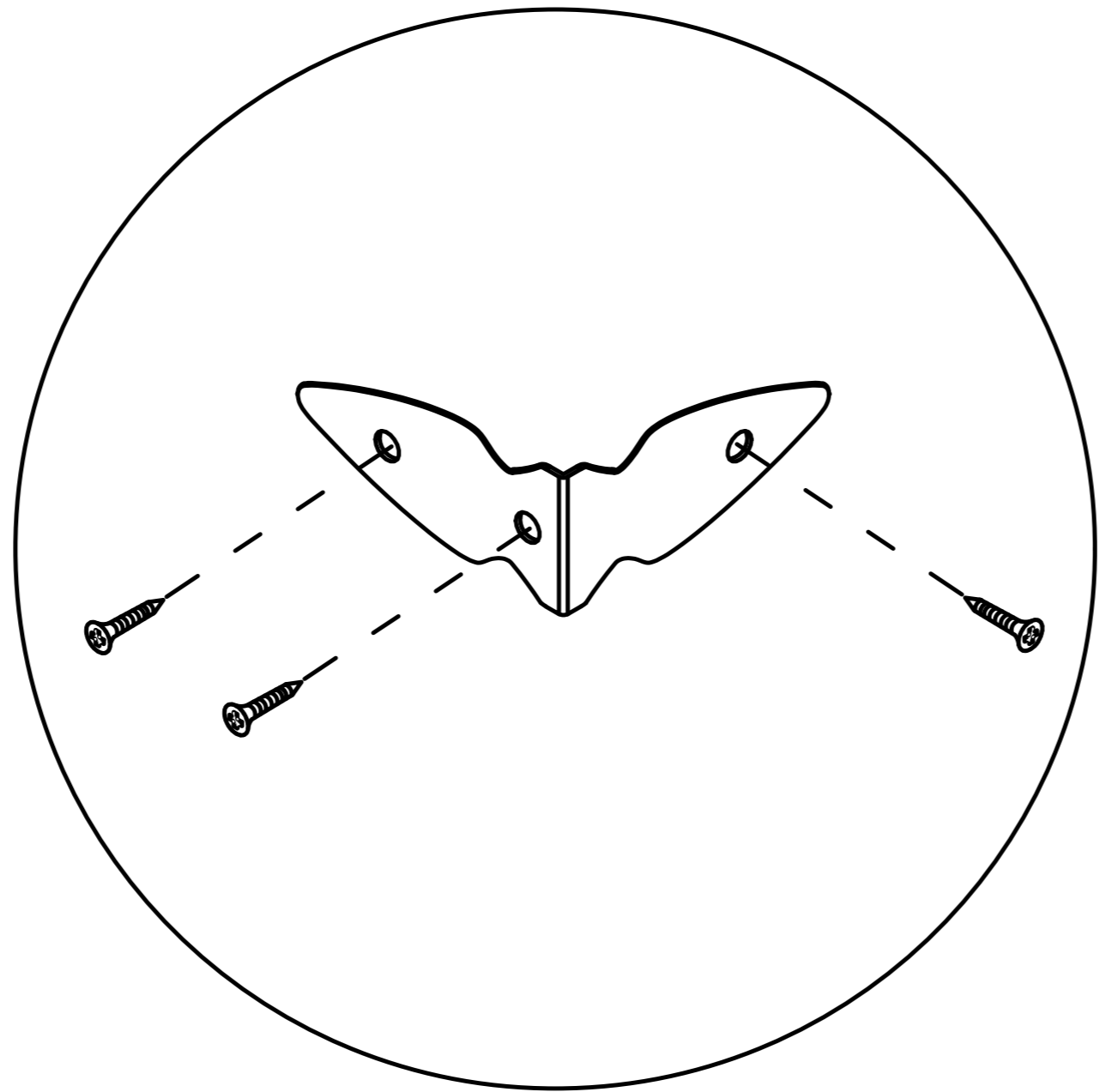
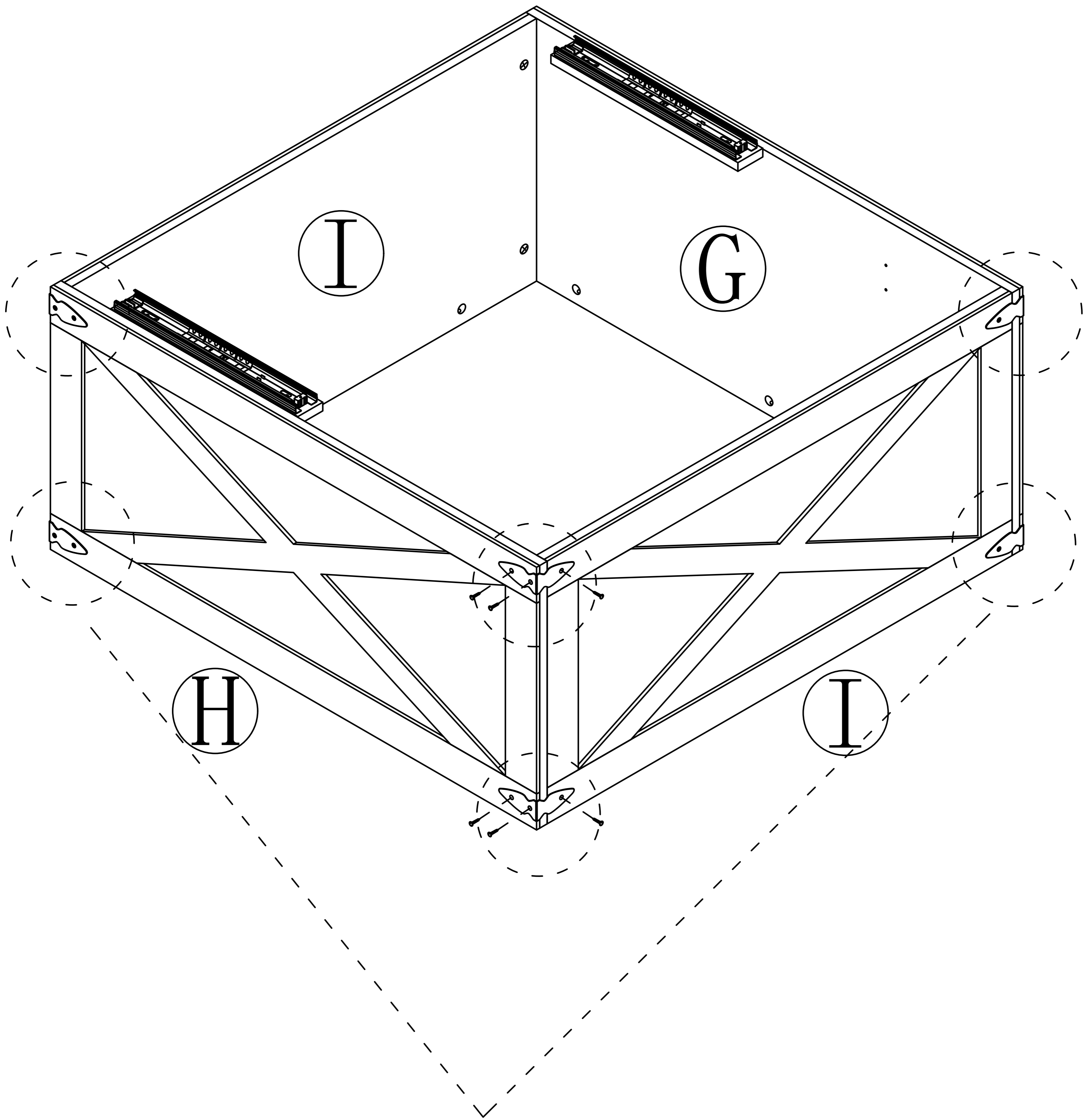

Step 15

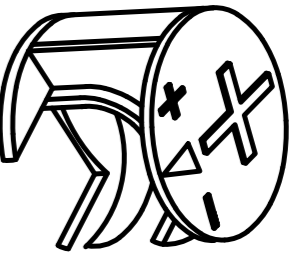
2  x10

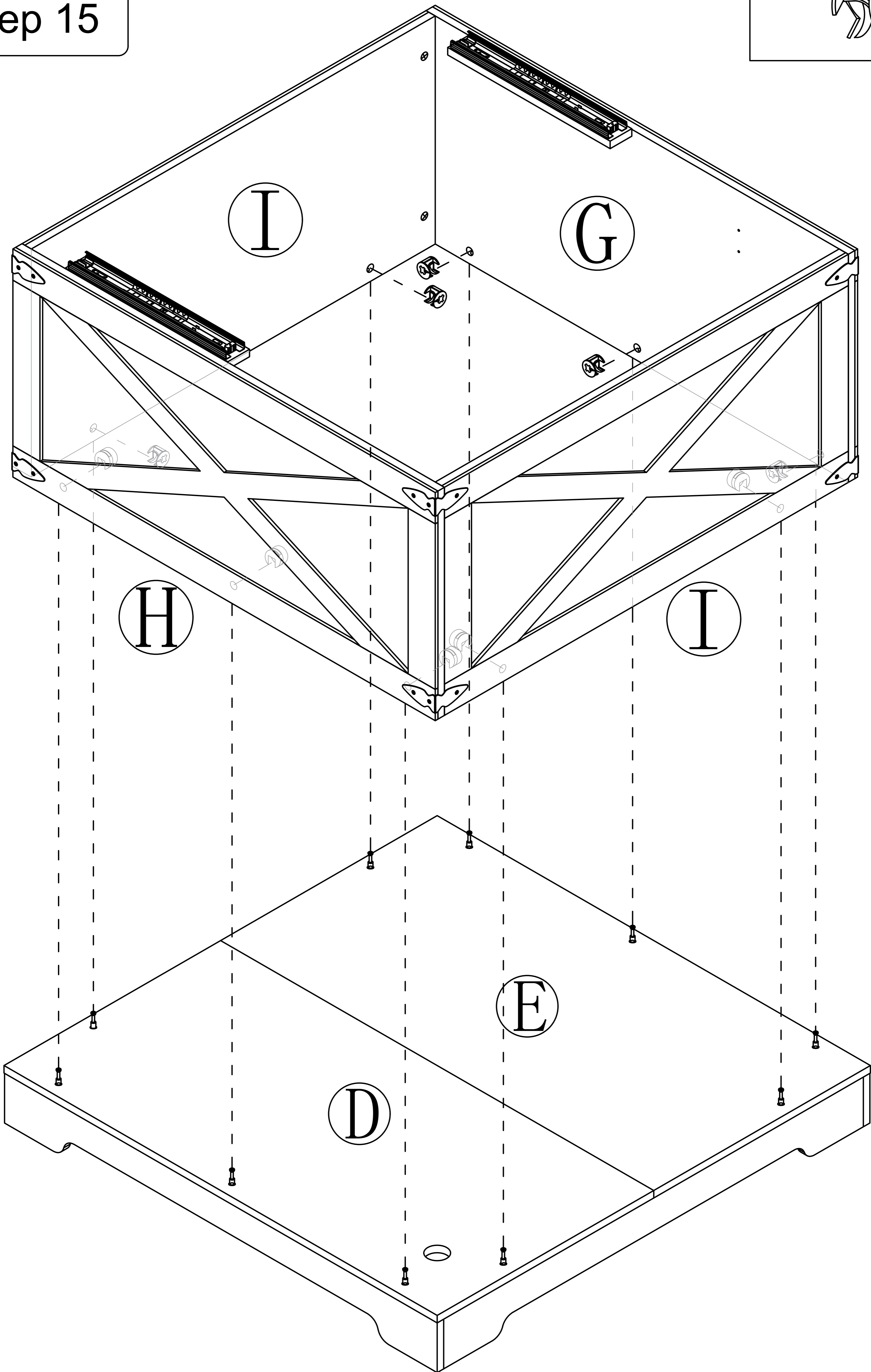

Note that plate H is installed corresponding to plate D

Step 16

3

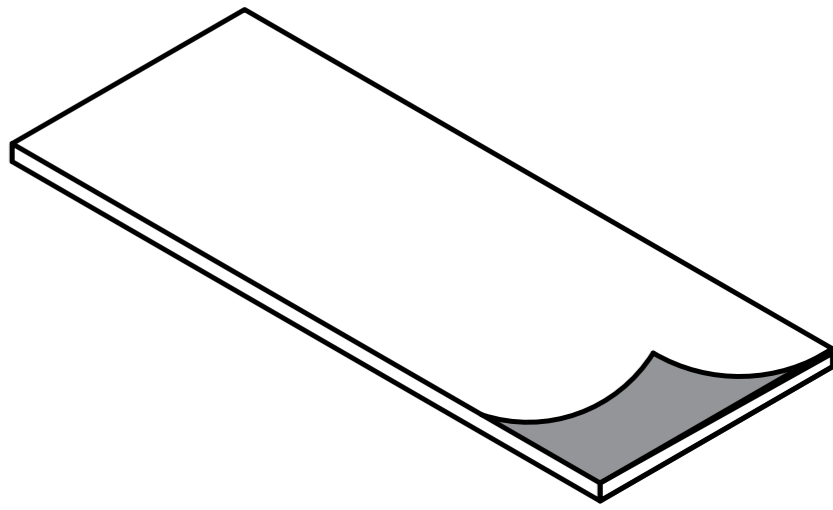

x7

Tear off release paper and stick the black mute pad on the board

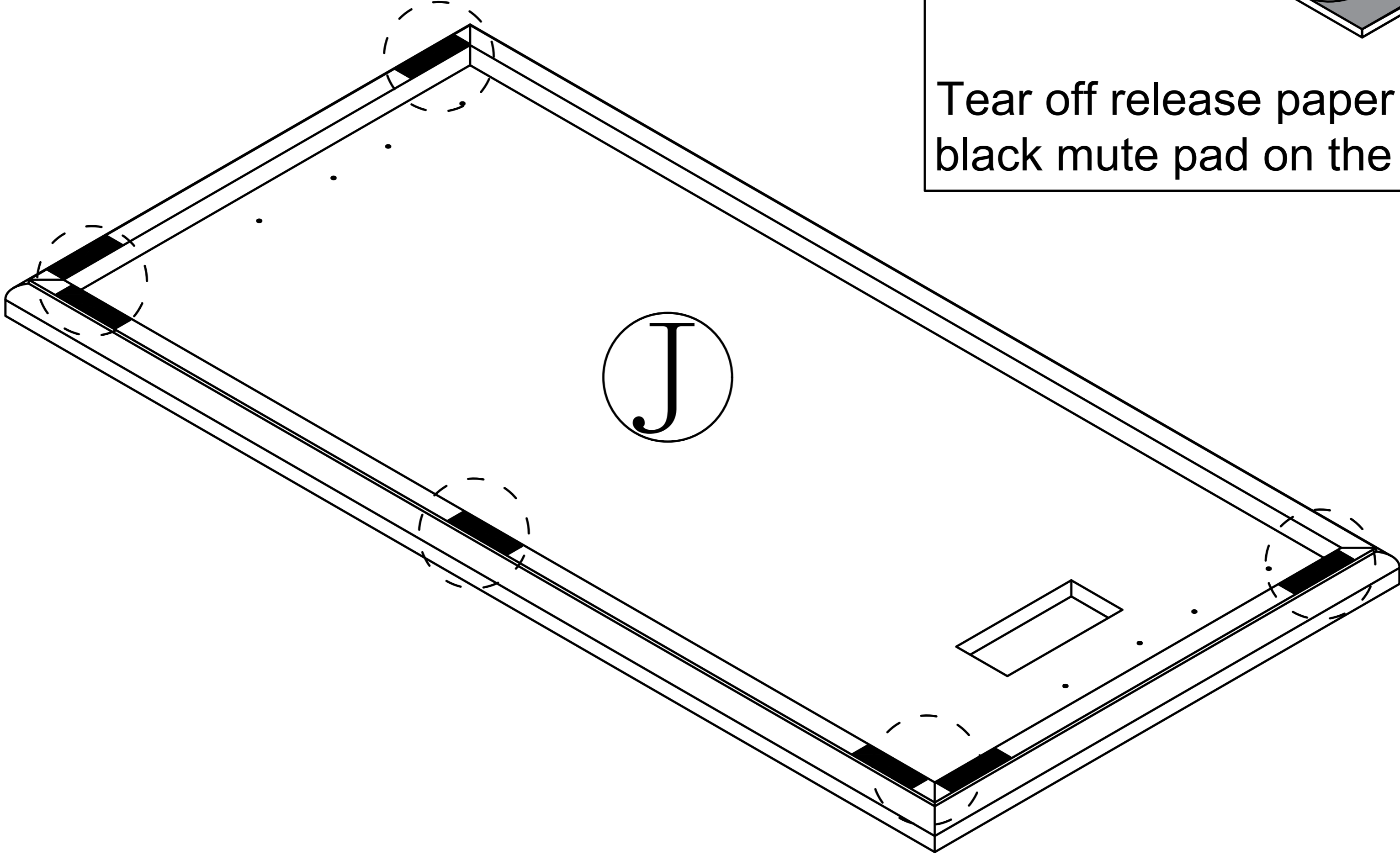

Step 17

5

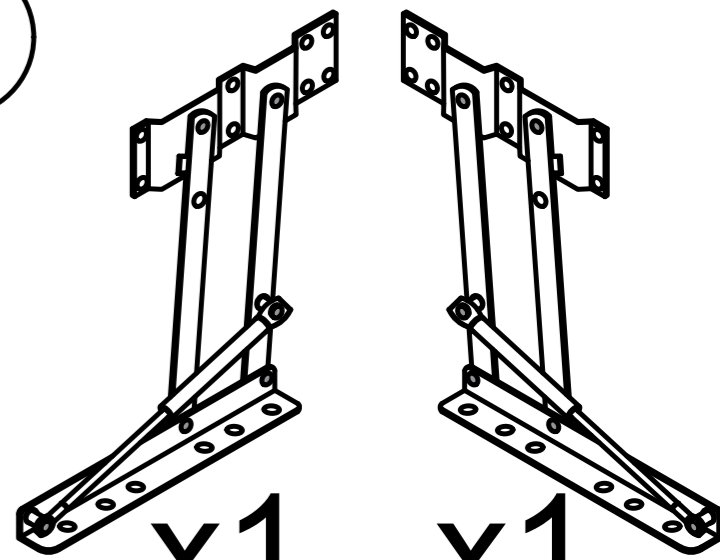

x1

x1

x8

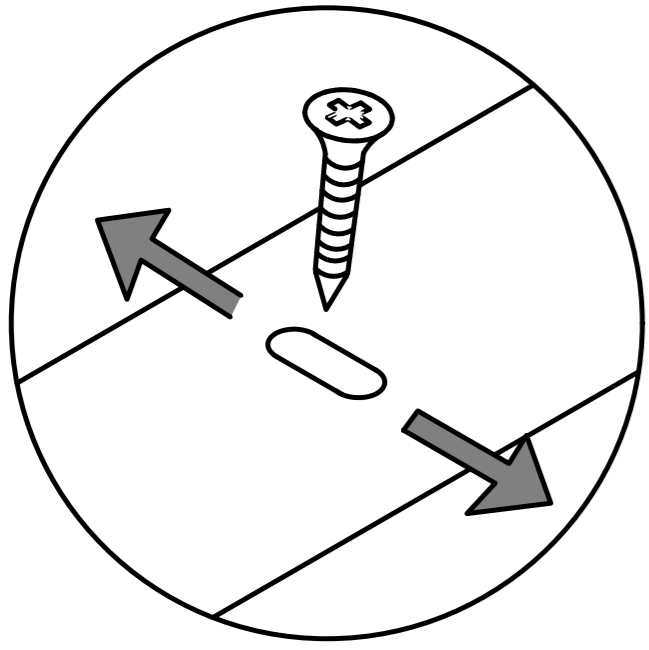
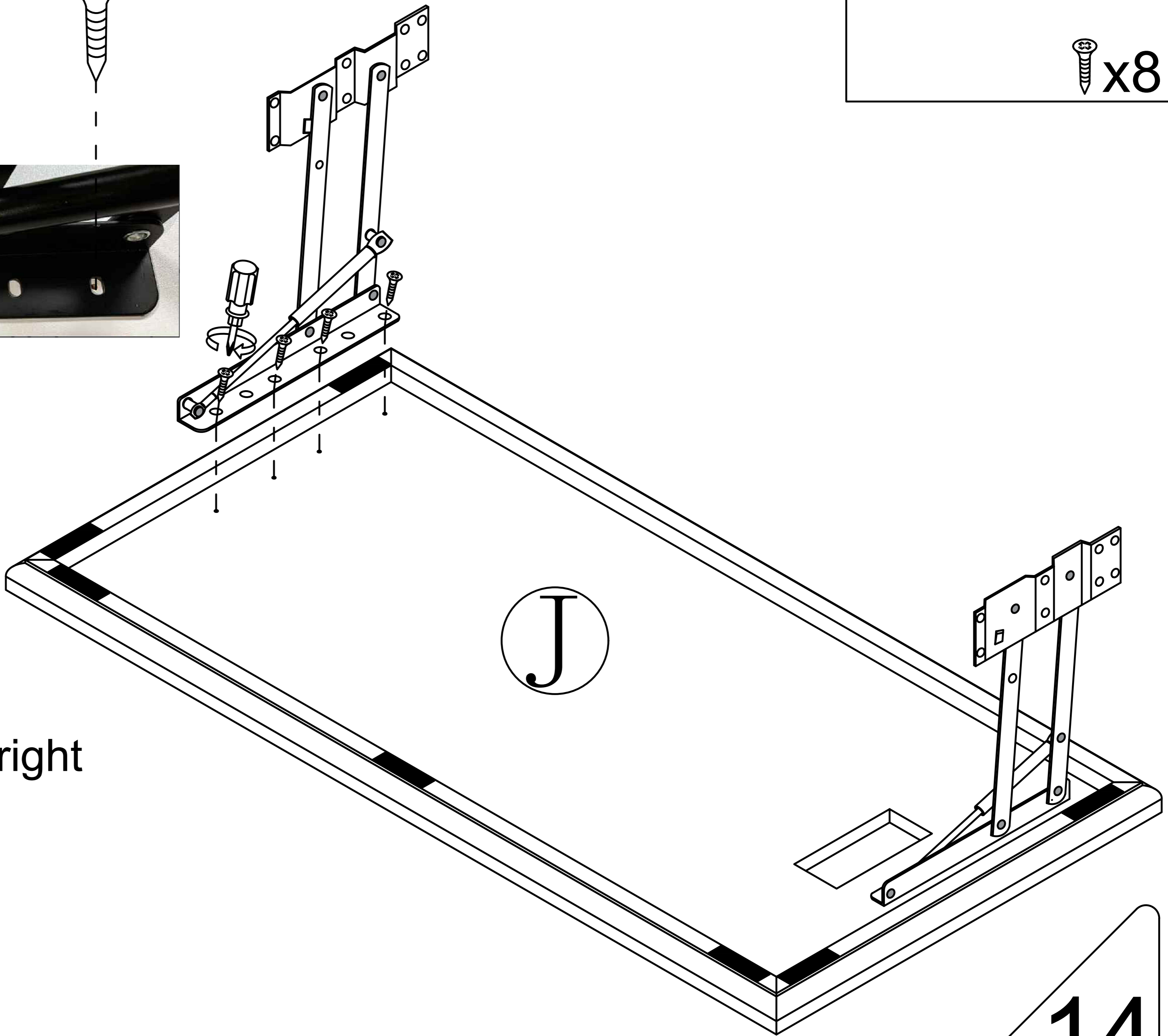
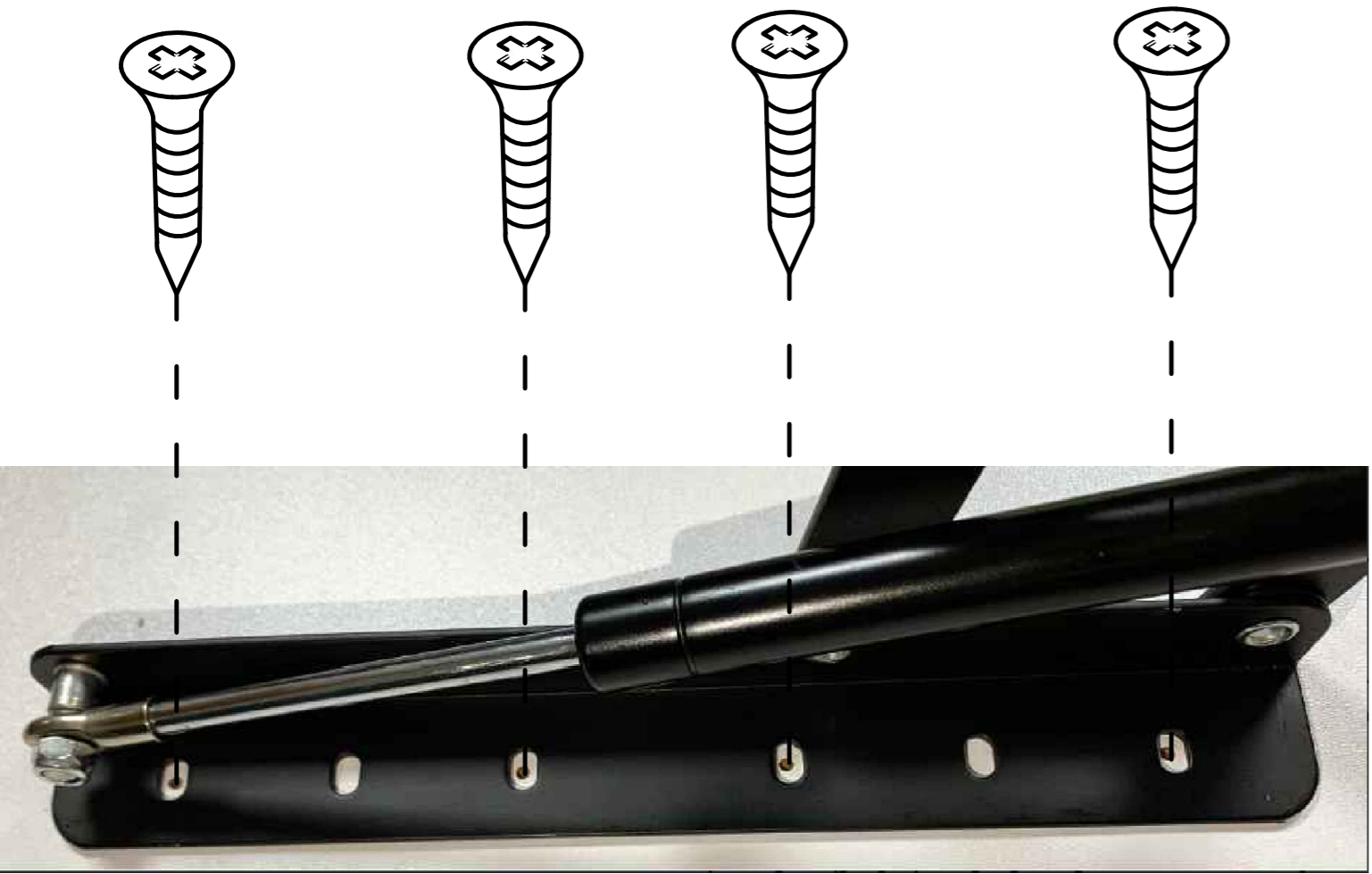

Adjustable left and right

Step 18

5 x8

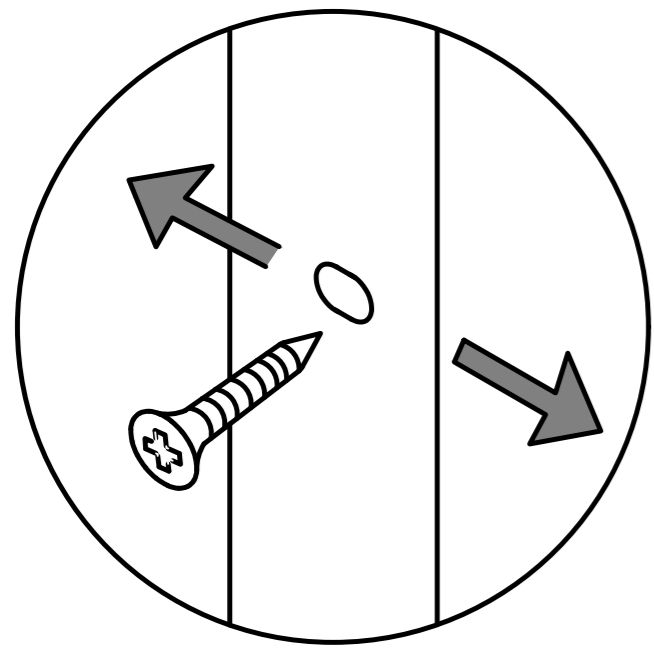

Adjustable back and forth

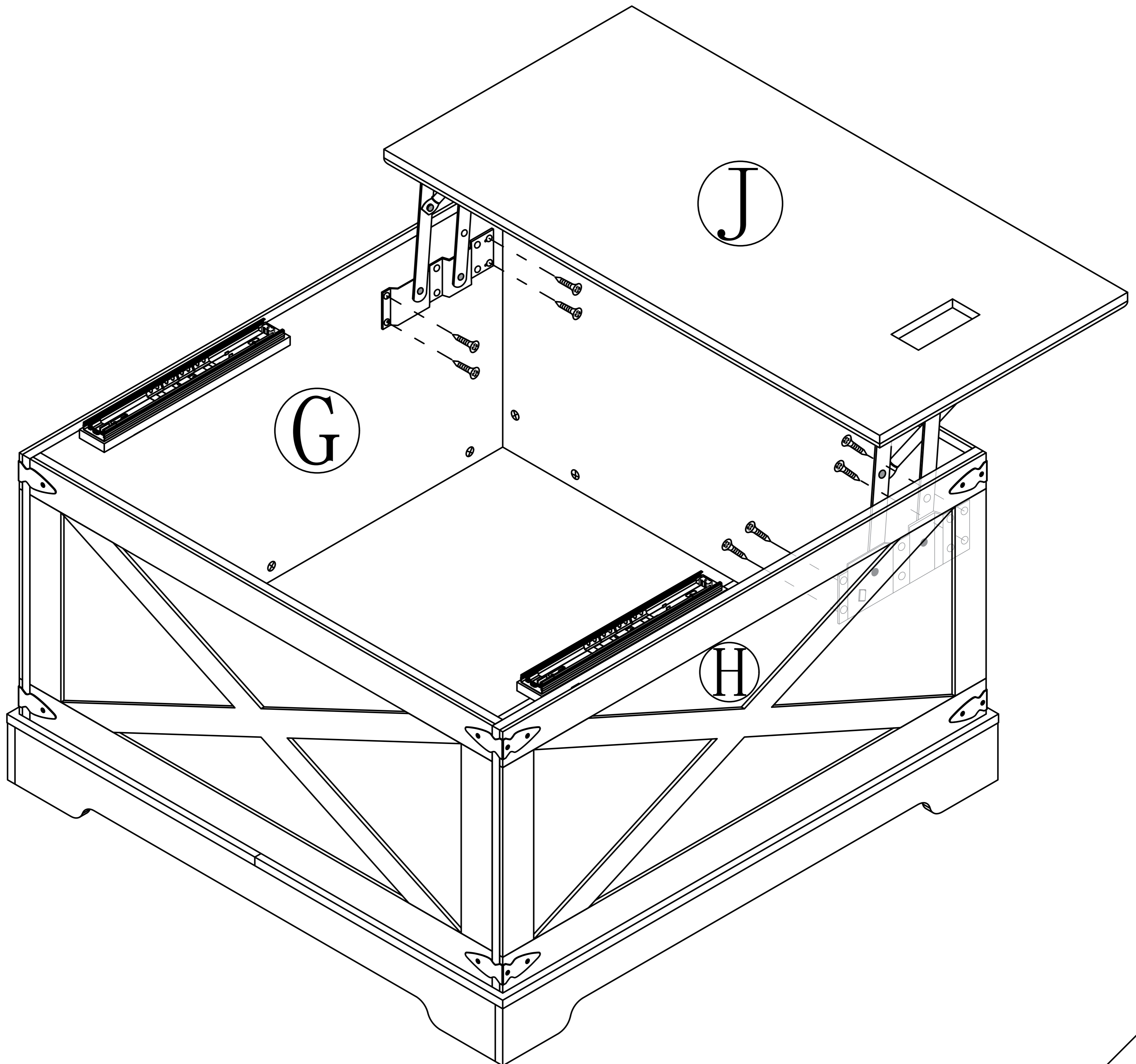

Step 19

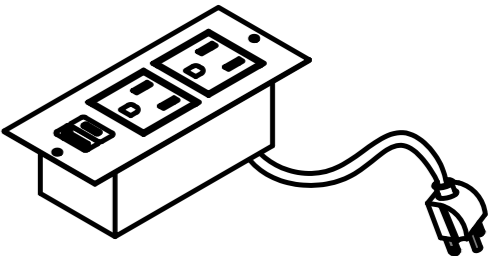
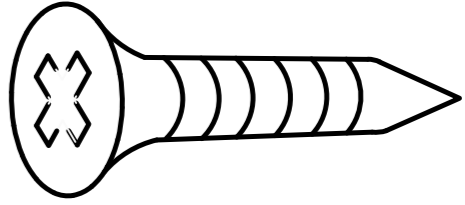
- 6  x1
-  x2

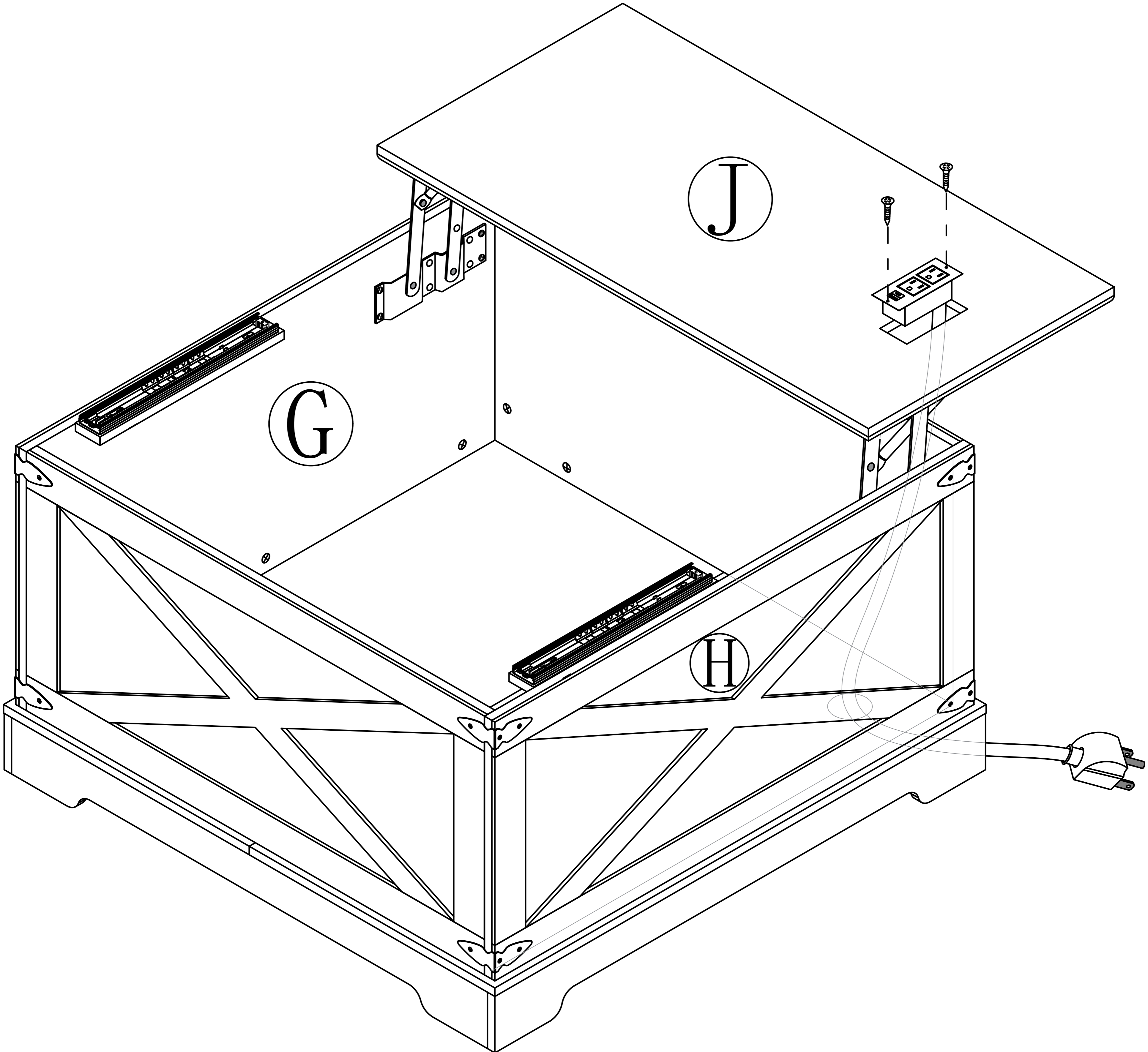

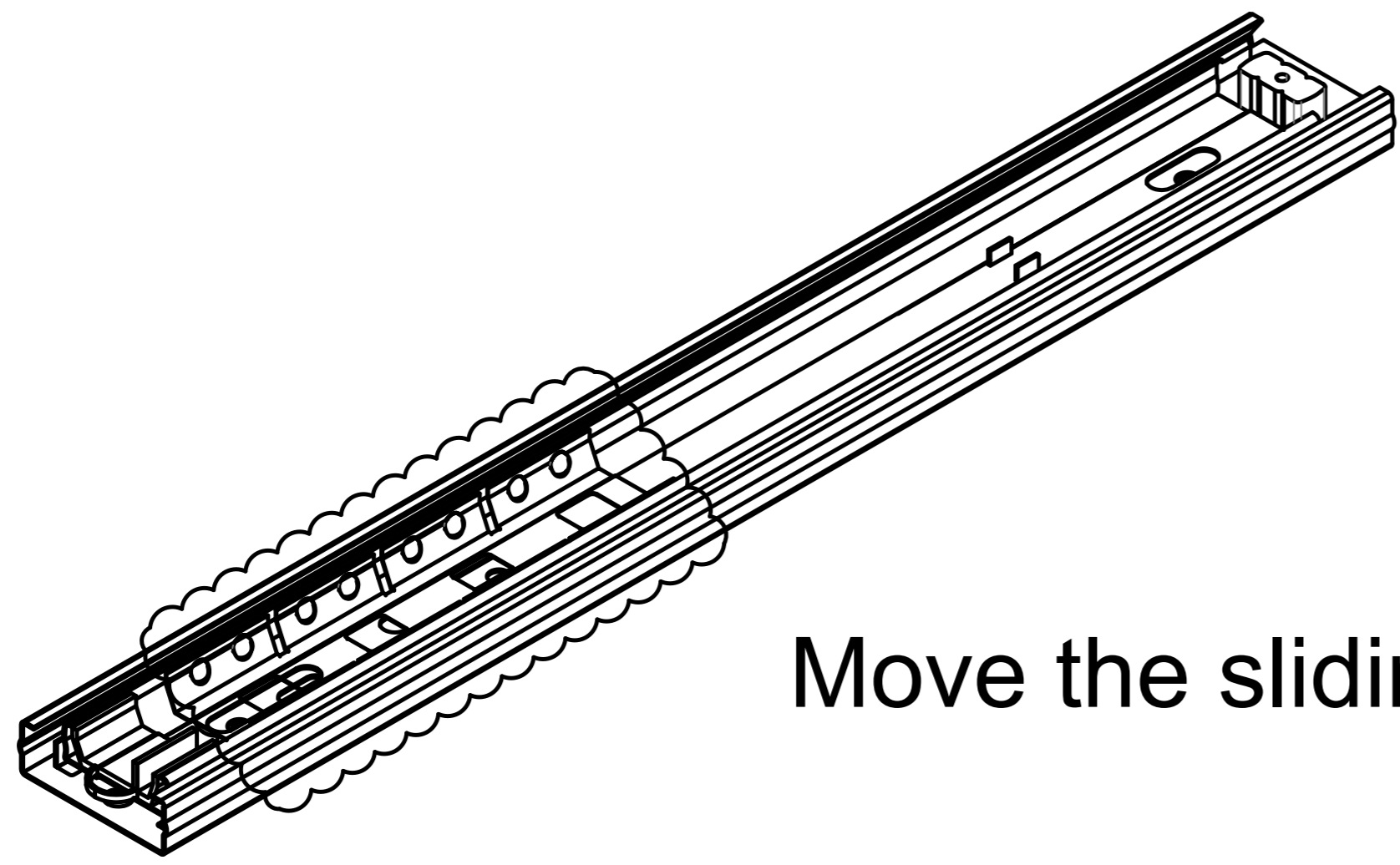

Move the sliding ball to the position shown in the picture

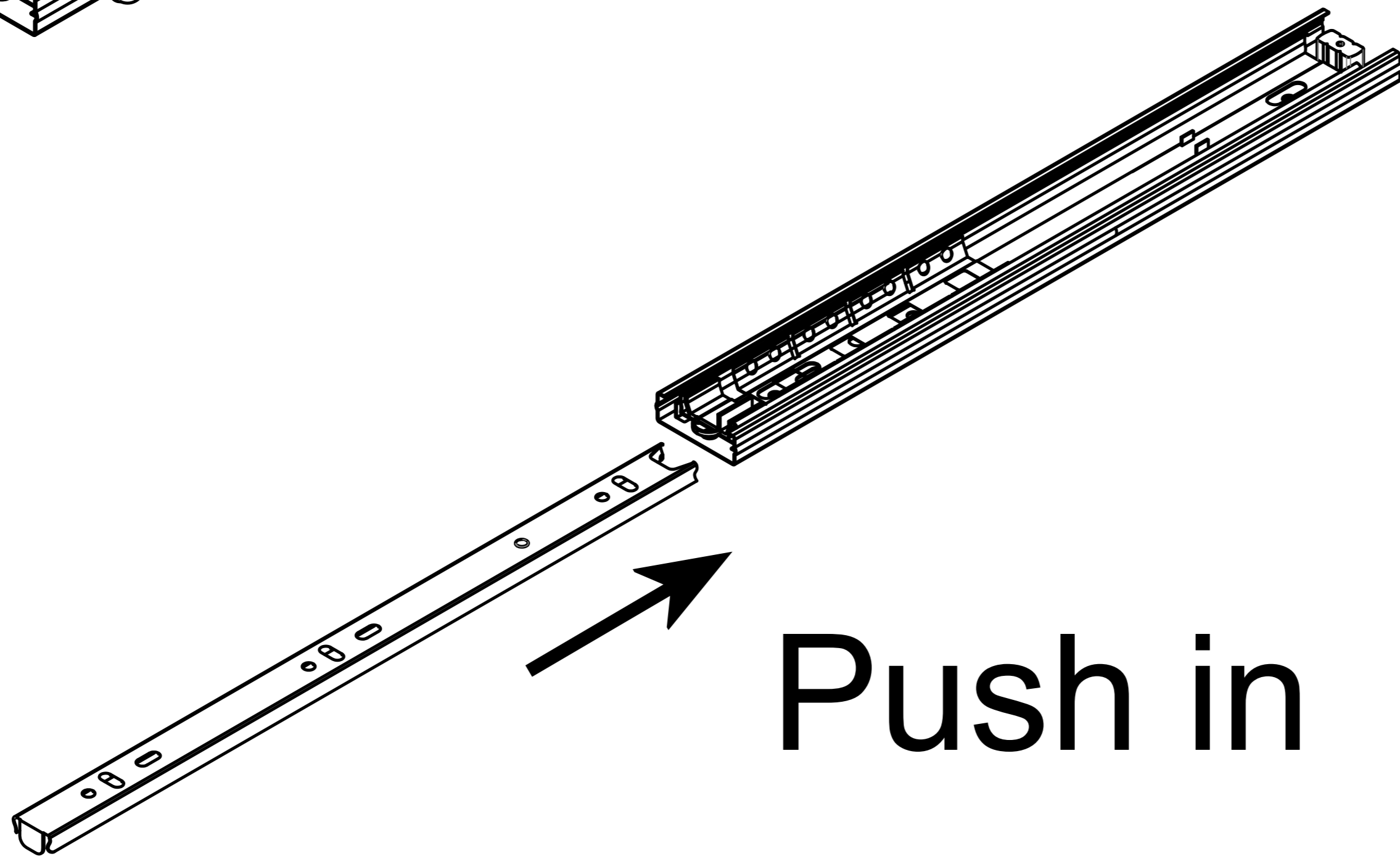

Push in

Step 20

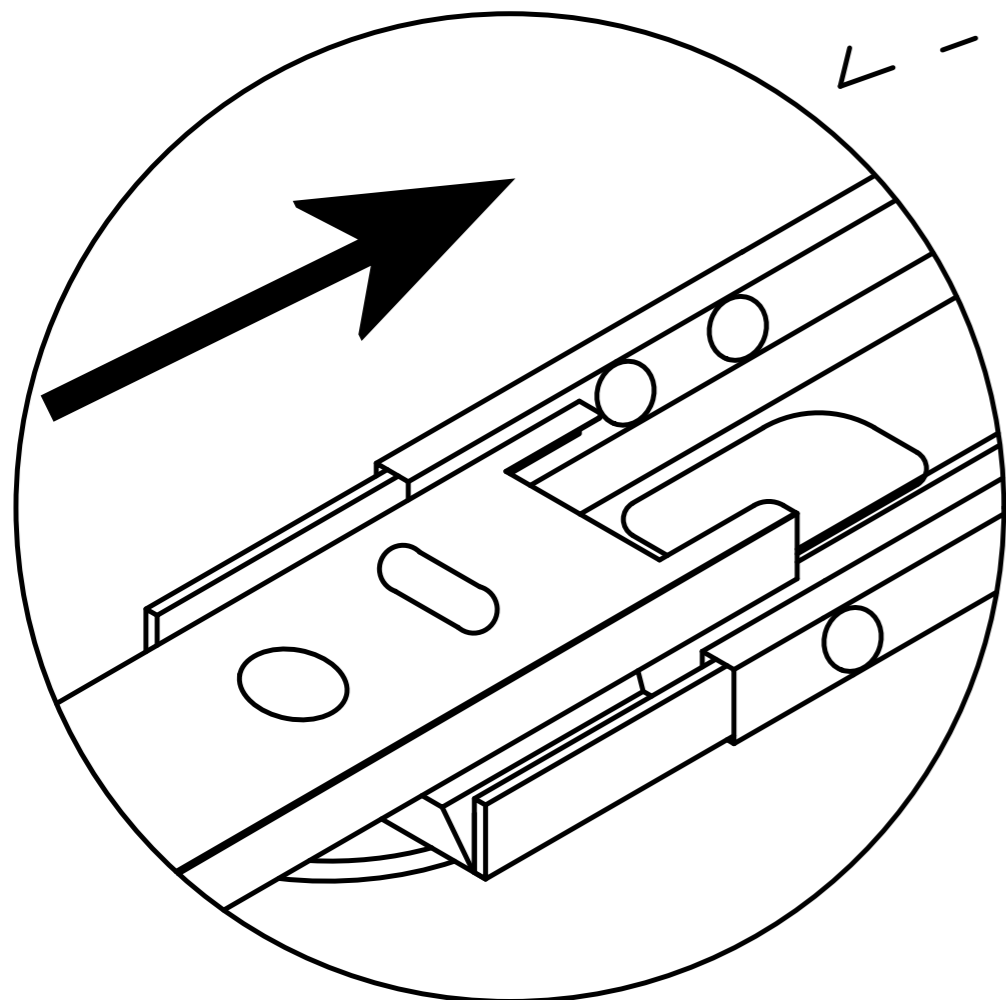
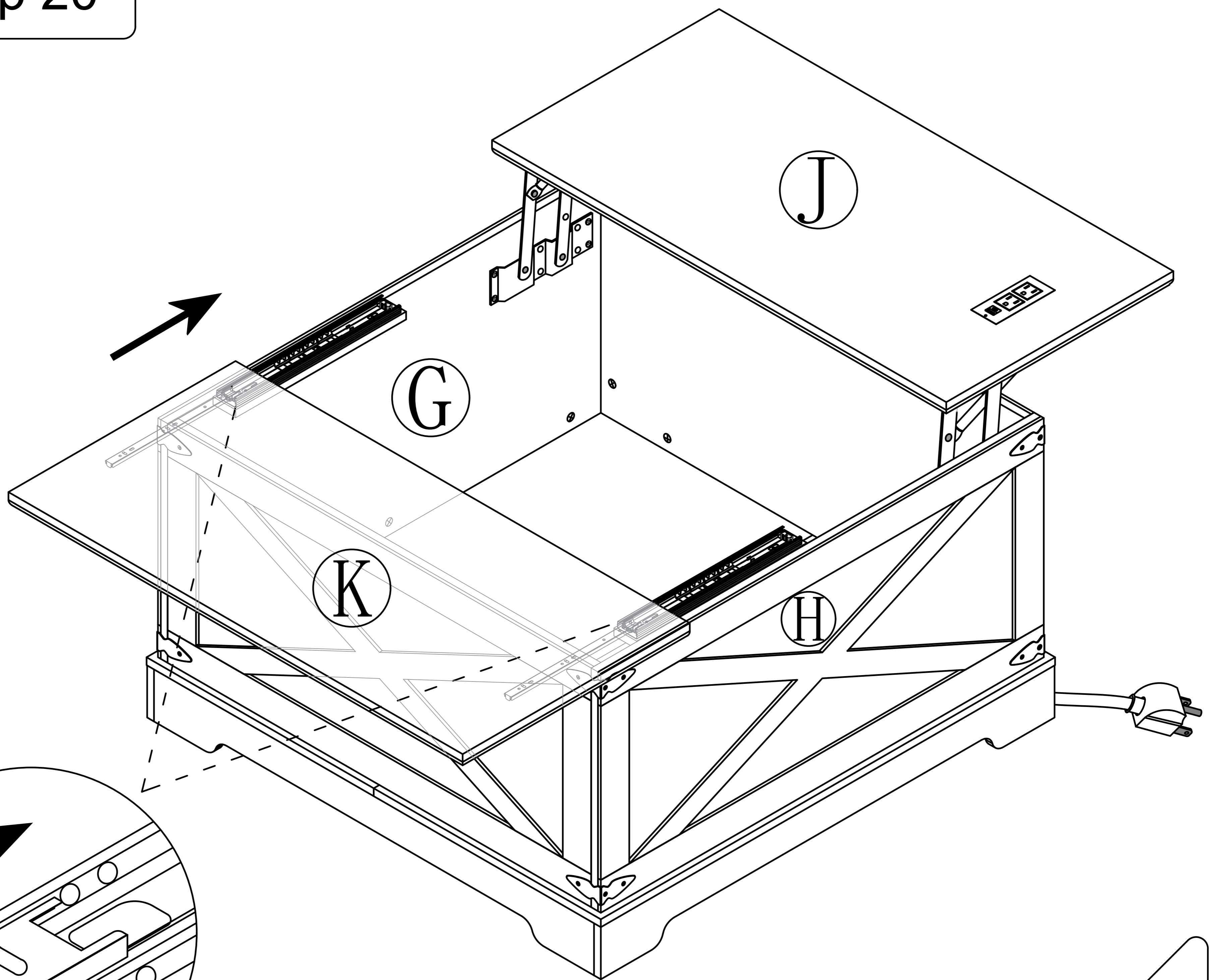

Step 21

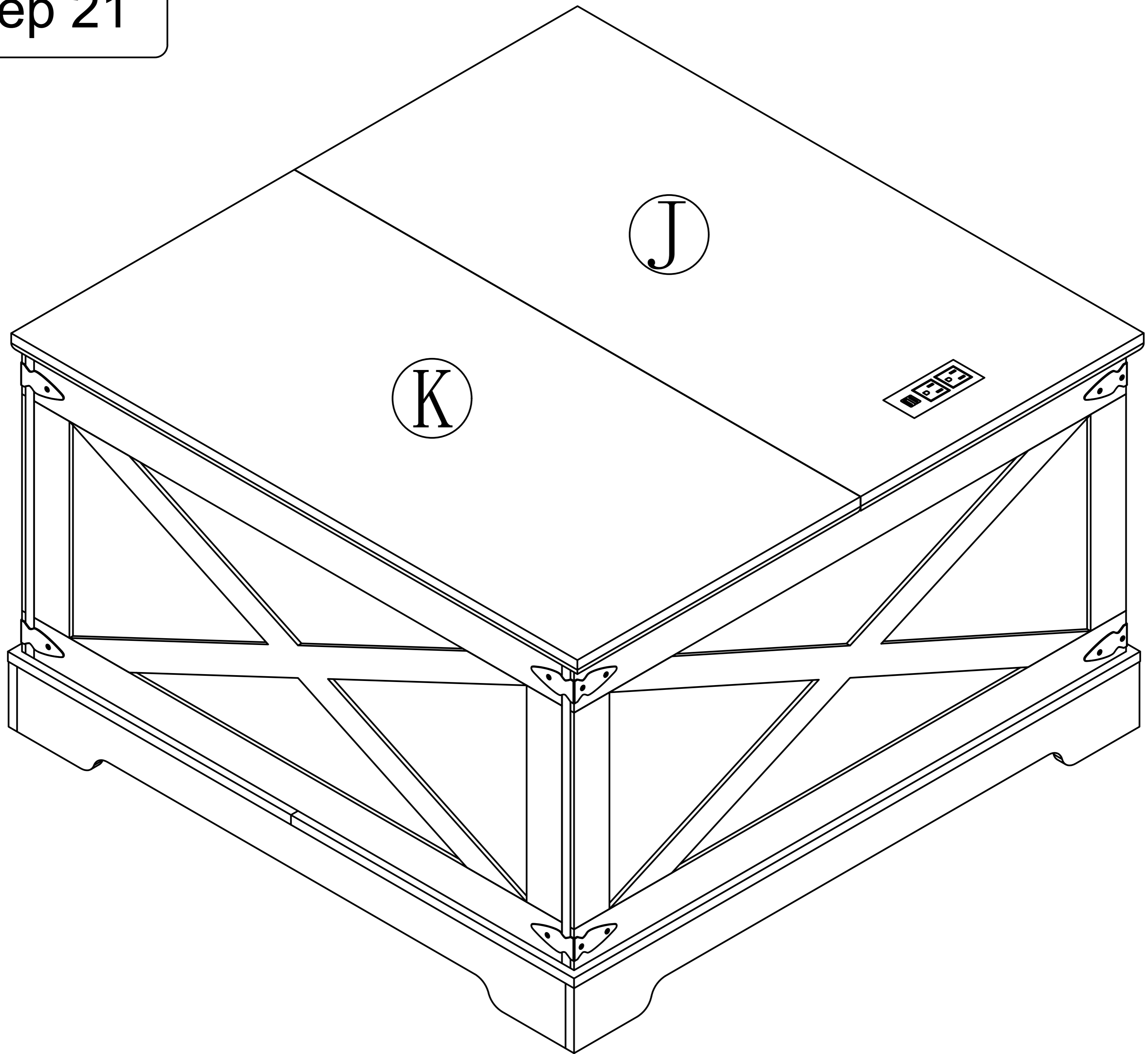

If there is a significant gap between the "J" board and the "K" board after installation, the gap between the "J" board and the "K" board can be adjusted by adjusting the screws



Adjustable back and forth

Step 22

Open

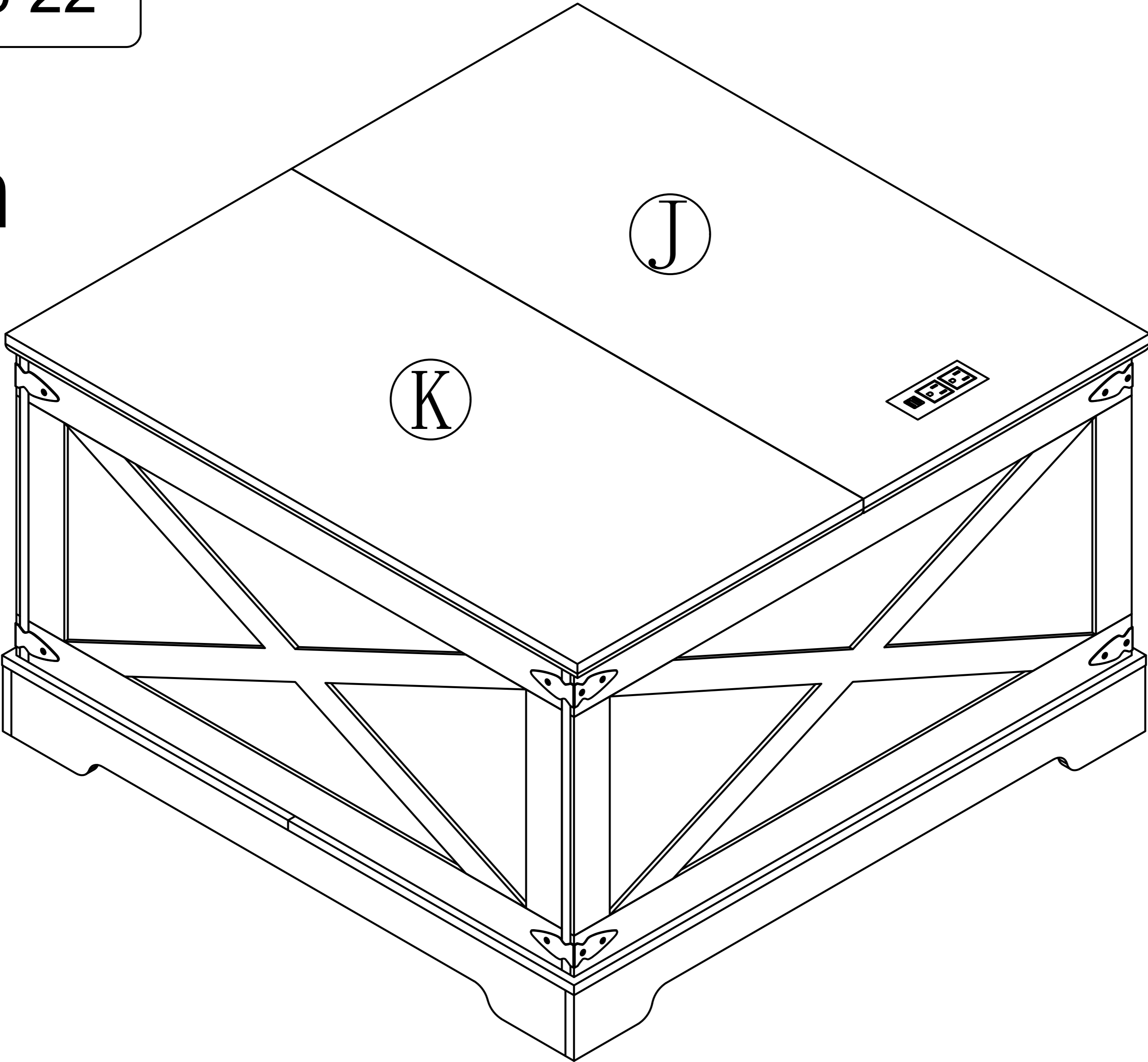

Close

