

ASSEMBLY INSTRUCTIONS

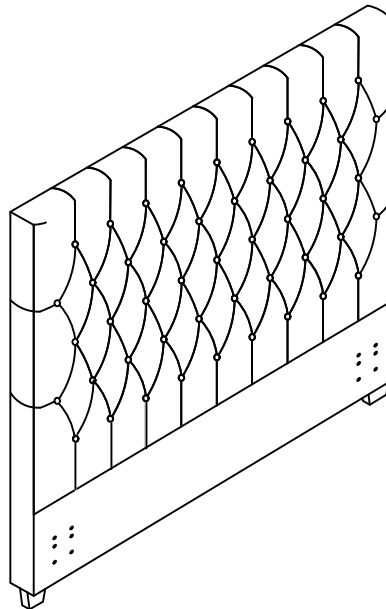

Queen Headboard

ASSEMBLY INSTRUCTIONS

ASSEMBLY TIPS:

1. Remove hardware from box and sort by size.
2. Please check to see that all hardware and parts are present prior to start of assembly.
3. Please follow attached instructions in the same sequence as numbered to assure fast & easy assembly.



WARNING!

1. Don't attempt to repair or modify parts that are broken or defective. Please contact the store immediately.
2. This product is for home use only and not intended for commercial establishments.

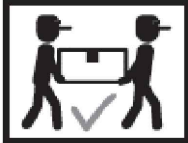

ASSEMBLY TIME

15 MINUTES

PARTS IDENTIFICATION

B1(BOX1)

AV HEADBOARD PANEL

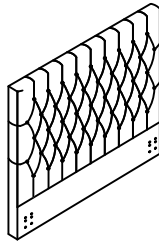

1PC

BV HEADBOARD LEG



2PCS

HARDWARE IDENTIFICATION

Z-B1(BOX1)-HARDWARE PACK IS LOCATED IN 30007Q(B1)

3 BOLT
(Ø 5/16 "X70mm-RBW)



2PCS

1 ALLEN WRENCH
(5MM-RBW)



1PC

9 HEX NUT
(6mmx13mmx13-RBW)



6PCS

11 BOLT
(Ø 1/4 "X38mm-RBW)



6PCS

13 SMALL FLAT WASHER
(Ø 1/4 "-RBW)



12PCS

2 FLAT WASHER
(Ø 5/16 "-RBW)



2PCS

10 WRENCH
(14MM-RBW)



1PC

12 SMALL LOCK WASHER
(Ø 1/4 "-RBW)



12PCS

ASSEMBLY INSTRUCTIONS

STEP 1

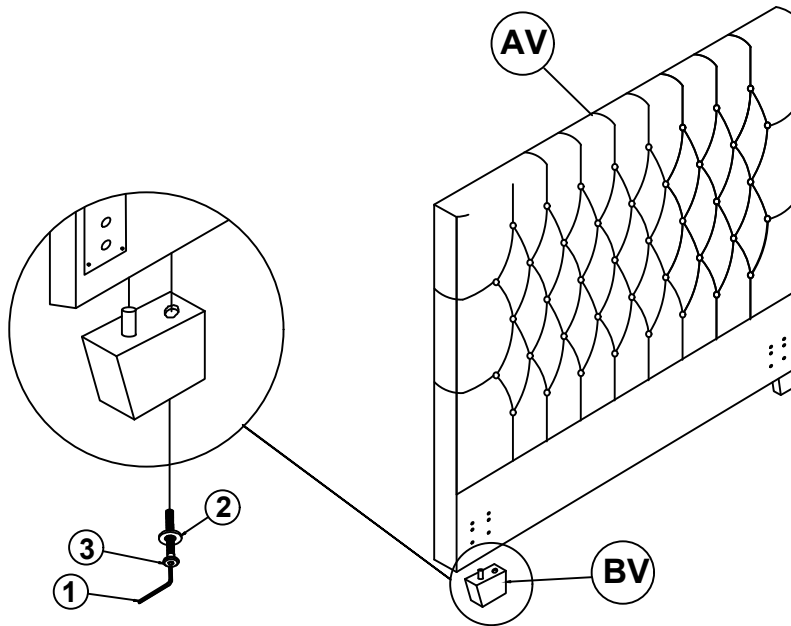

STEP 2 COMPLETE

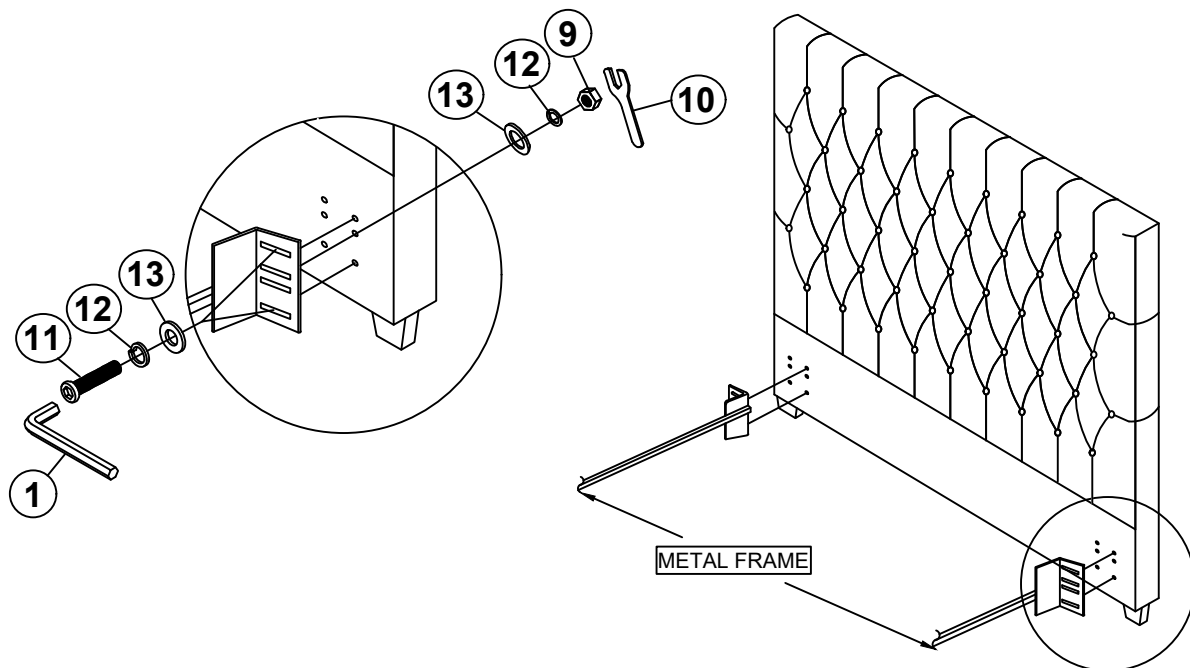

Inner Size: 61.00"W X 81.25"D

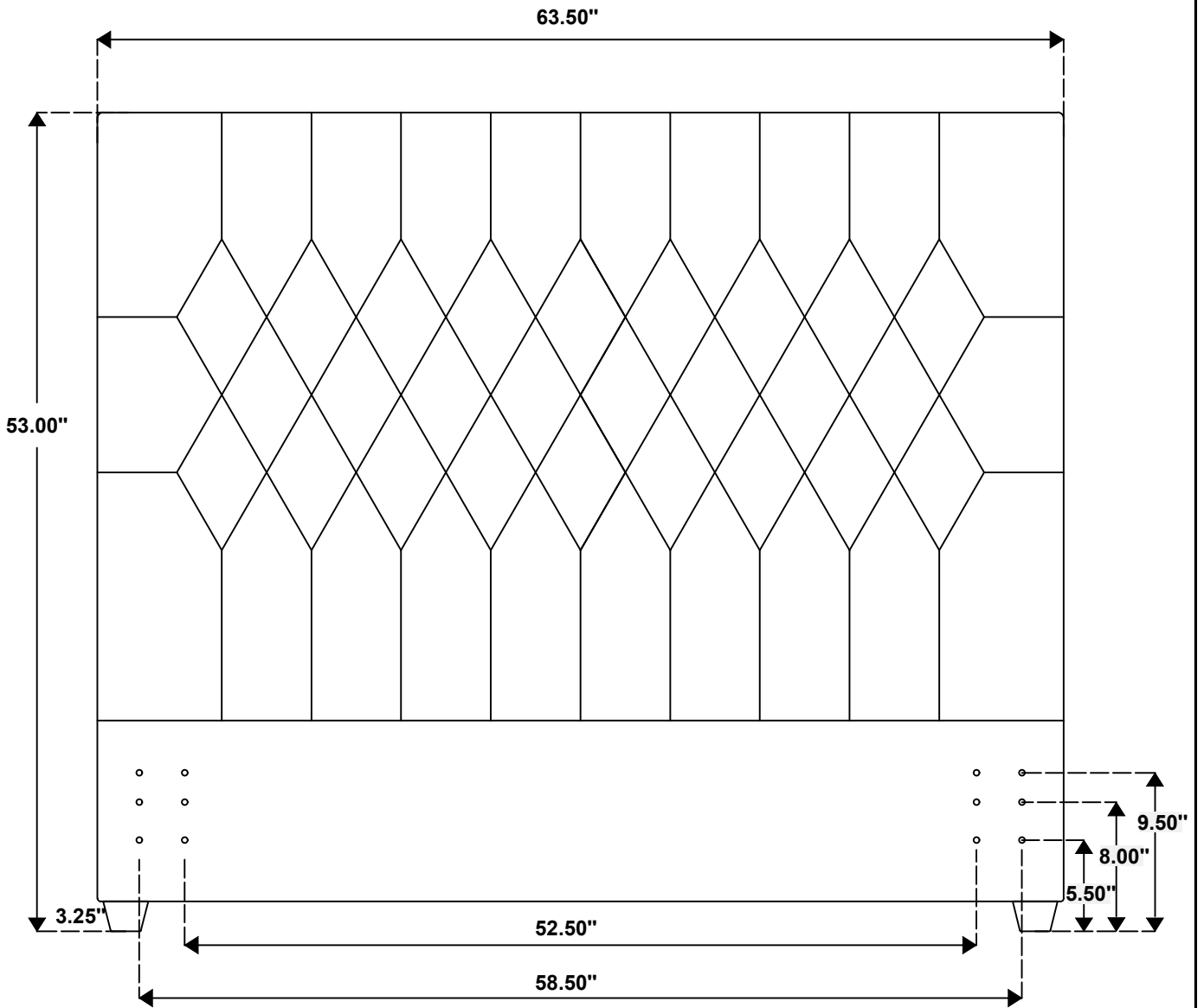

Note: Dimension tolerance $\pm 5\%$