

Assembly Instructions

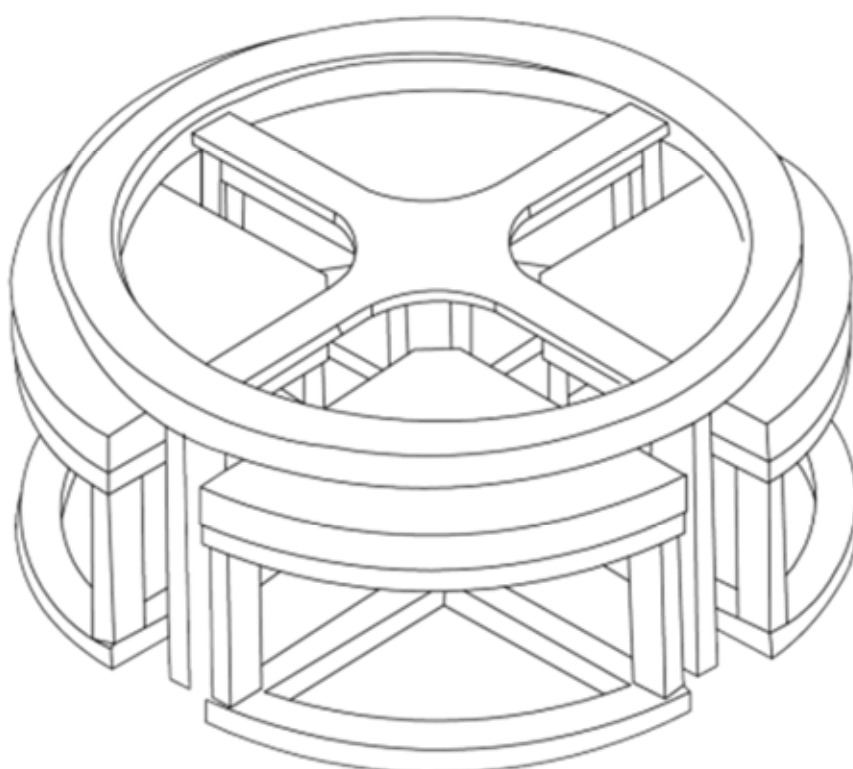

ASSEMBLY RATING

The Assembly Rating is a 5-point system that shows the degree of effort needed in assembling a specific product (with 1 being easy and 5 being difficult). For some products, two persons are recommended.

EASY  DIFFICULT

Tools Required for Assembly:

Allen Wrench

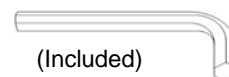

(Included)

Phillips Screwdriver



(Not Included)



2 PERSONS RECOMMENDED

ASSEMBLY & CARE ADVICE

FOR YOUR FURNITURE TO LAST, CORRECT ASSEMBLY AND PROPER MAINTENANCE ARE NECESSARY. PLEASE FOLLOW THE INFORMATION PROVIDED BELOW TO FULLY ENJOY YOUR FURNITURE.

BASIC ASSEMBLY TECHNIQUES

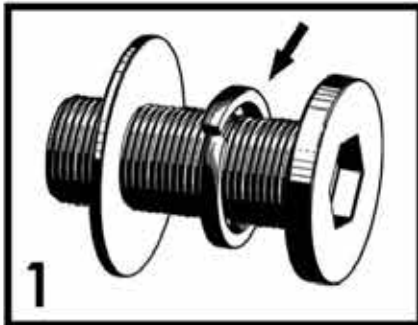

1 When lock or spring washer is used in an assembly, please make sure the lock or spring washer is placed between the larger flat washer and the head of the screw or bolt.

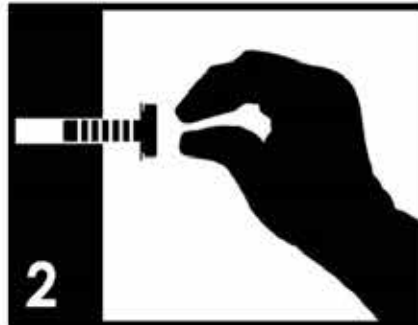

2 Position each part correctly and insert screws or bolts into their respective holes by hand tighten or using the proper hand tool. Only tighten when step is completed or when instructed to do so.



3 Use cardboard or carpet area when assembling furniture to prevent scratches. Make sure the furniture rests on a flat and level surface with each leg evenly touching the floor.

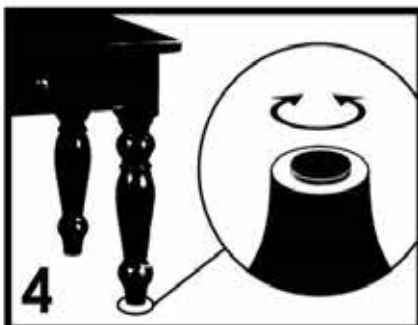

4 Some furniture comes with height adjustment knobs underneath each leg. To lower or to raise each leg, you need to turn clockwise or counterclockwise, respectively.

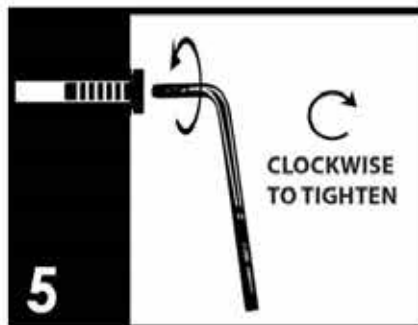

5 Make sure all parts are properly aligned, then use the appropriate hand tool to completely tighten the bolts or screws. Do not use power tools and do not overtighten.

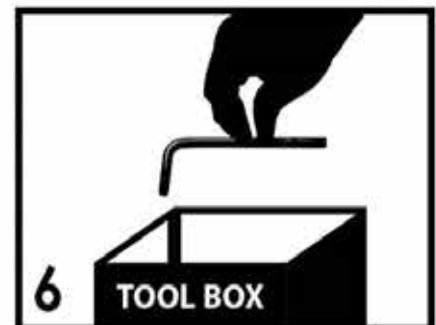

6 Save the instructions and store the Allen wrench or any supplied tool for later maintenance. After two weeks, check and tighten any loose hardware and repeat again every six months thereafter.

IT IS THE USER'S RESPONSIBILITY TO MAINTAIN THE FURNITURE. THE HARDWARE MAY LOOSEN OVER TIME AND MAY CAUSE THE FURNITURE TO BE WOBBLY AND UNABLE TO SUPPORT ITS INTENDED WEIGHT CAPACITY. THIS MAY LEAD TO COLLAPSE AND MAY CAUSE SERIOUS INJURY.



FAILURE TO FOLLOW THE GUIDELINES ABOVE MAY RESULT IN INJURY AND/OR PROPERTY DAMAGE.







Before you begin, please read Page 2 of "Assembly and Care Advice".







And remember, do not tighten until each step is completed or instructed.

MD

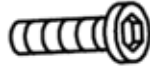
Parts List

-  #1 x 1 pc
Table Top
-  #2 x 1 pc
Leg A
-  #3 x 1 pc
Leg B
-  #4 x 1 pc
Glass Top

Hardware List

-  #A x 12 pcs
Bolt 5/16"x7/8"
-  #B x 8 pcs
Flat Bolt 5/16"x7/8"
-  #C x 12 pcs
Lock Washer
-  #D x 12 pcs
Flat Washer
-  #E x 1 pc
Allen Wrench
-  #F x 1 pc
4-Way Bracket
-  #G x 4 pcs
Bracket

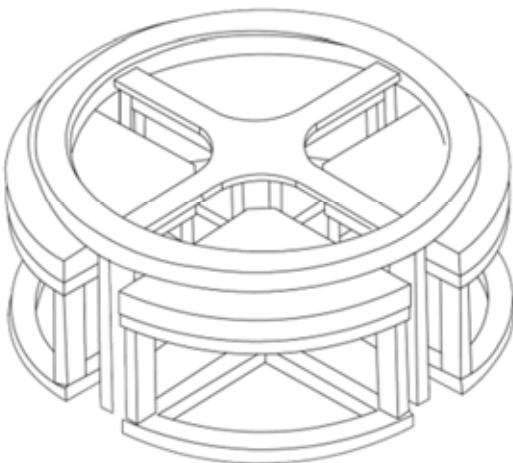



Align the two brackets (#G) with the pre-drilled holes of the leg A (#2). Insert 4 bolts (#B) into the brackets (#G) using the Allen wrench (#E) to lock them with the leg A (#2).

#B x 4 pcs
#G x 2 pcs

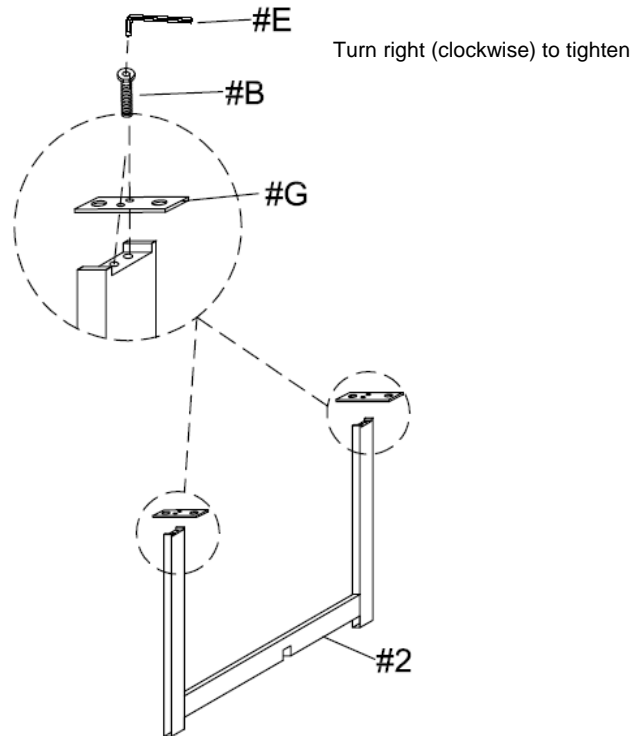

Align the two brackets (#G) with the pre-drilled holes of the leg B (#3). Insert 4 bolts (#B) into the brackets (#G) using the Allen wrench (#E) to lock them in with the leg B (#3).

#B x 4 pcs
#G x 2 pcs

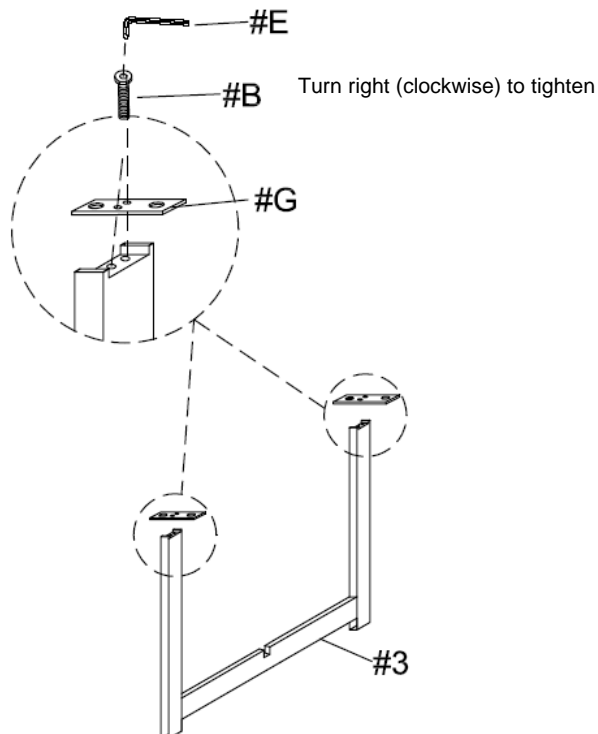



- I. Carefully place the table top (#1) facing down on a protected surface.
- II. Align the brackets (#G) assembled on the leg A (#2) AND the leg B (#3) with the pre-drilled holes on the bottom of the table top (#1).
- III. Prepare 8 bolt assemblies by inserting FIRST the lock washer (#C) onto the bolt (#A) and then the flat washer (#D) onto the SAME bolt (#A), in that order.
- IV. Insert the bolt assemblies through the pre-drilled holes on the brackets (#G) and secure those bolts using the Allen wrench (#E) to lock them with the table top (#1).
- V. Align the 4-way bracket (#F) onto the center of the leg A (#2) and the leg B (#3).
- VI. Prepare 4 bolt assemblies by inserting FIRST the lock washer (#C) onto the bolt (#A) and then the flat washer (#D) onto the SAME bolt (#A), in that order.
- VII. Insert the bolt assemblies through the pre-drilled holes on the 4-way bracket (#F) and secure those bolts using the Allen wrench (#E) to lock them with the leg A (#2) AND the leg B (#3).
- VIII. Carefully turn the table upright. Place the glass top (#4) onto the table top (#1). Make sure the table is rested on a flat surface and it does not feel loose or wobbly. If it does, double check that the bolts/screws are secured and properly tighten.

Turn right (clockwise) to tighten

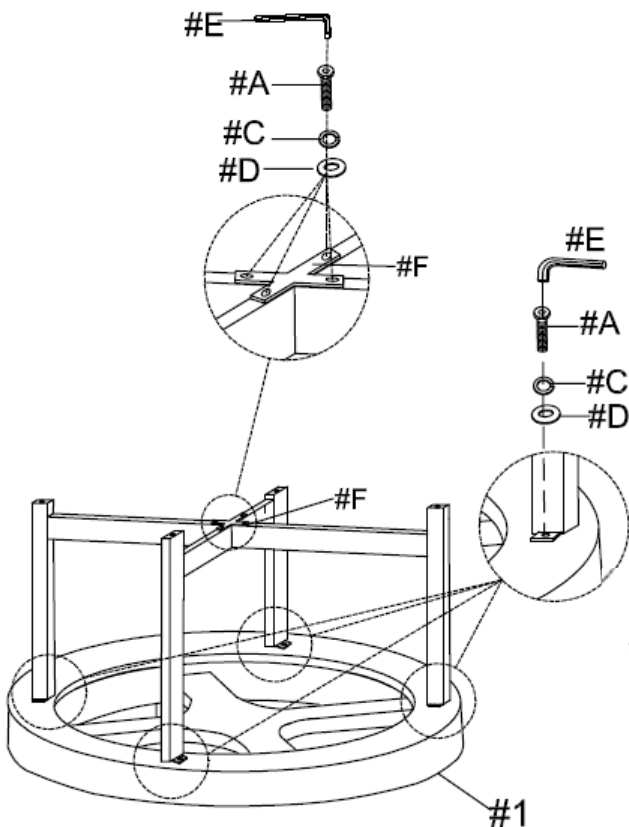

#A x 12 pcs
#C x 12 pcs
#D x 12 pcs
#F x 1 pc

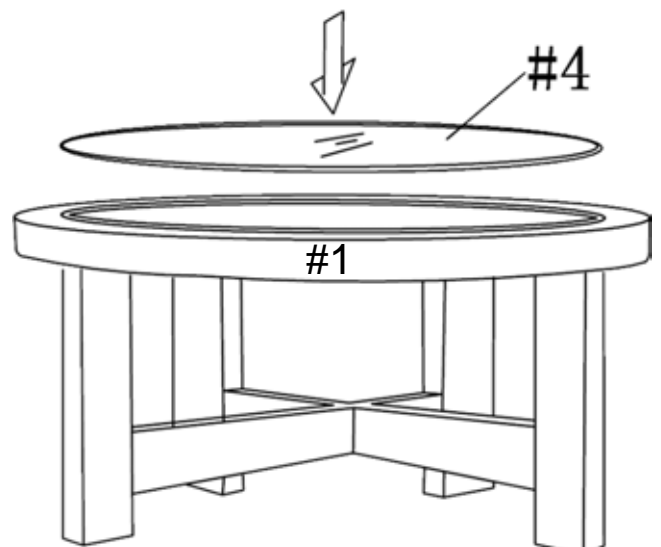

ASSEMBLY IS COMPLETED







Before you begin, please read Page 2 of "Assembly and Care Advice".





And remember, do not tighten until each step is completed or instructed.

MD

Parts List

-  #1 x 1 pc x 4
Seat Cushion
-  #2 x 1 pc x 4
Seat Frame
-  #3 x 1 pc x 4
Base
-  #4 x 1 pc x 4
Center Leg
-  #5 x 2 pcs x 4
Side Leg

Hardware List

-  #A x 6 pcs x 4
Bolt 5/16"x1-3/4"
-  #B x 6 pcs x 4
Lock Washer
-  #C x 6 pcs x 4
Flat Washer
-  #D x 1 pc
Allen Wrench
-  #E x 4 pcs x 4
Screw

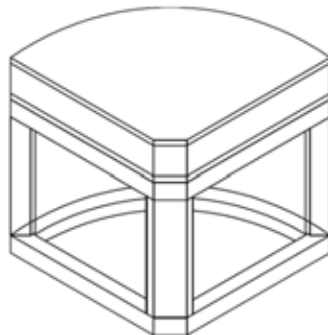

X 4



Note: The above parts and hardware are shown for a complete assembly of ONE chair. However, the actual parts and hardware (with an exception of the Allen wrench) in the box will be four times the quantities listed to include the assembly of the second, third and fourth chairs.



#A x 3 pcs
#B x 3 pcs
#C x 3 pcs

- I. Insert the center leg (#4) and the two side legs (#5) into the seat frame (#2).
- II. Prepare 3 bolt assemblies by inserting FIRST the lock washer (#B) onto the bolt (#A) and then the flat washer (#C) onto the SAME bolt (#A), in that order.
- III. Insert the bolt assemblies through the pre-drilled holes on the seat frame (#2) and secure those bolts using the Allen wrench (#D) to lock them with the center leg (#4) and the two side legs (#5).

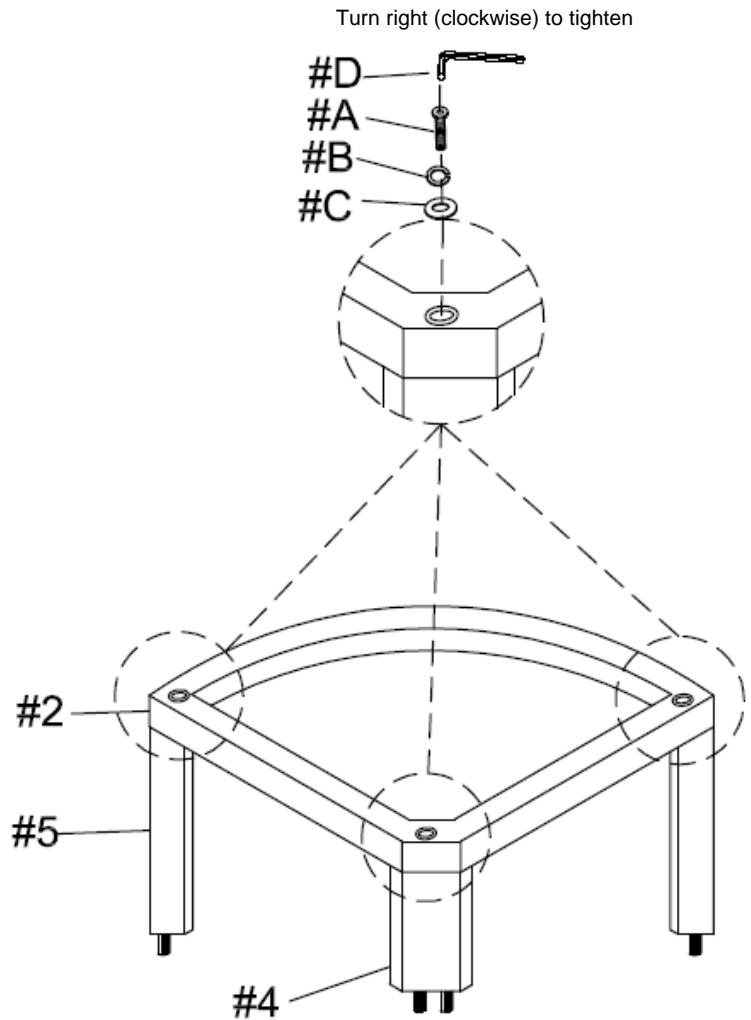

Align the seat cushion (#1) onto the top of the seat frame (#2). Tighten 4 screws (#E) through the bottom of the seat frame (#2) using the Phillips screwdriver to secure them with the seat cushion (#1).

#E x 4 pcs

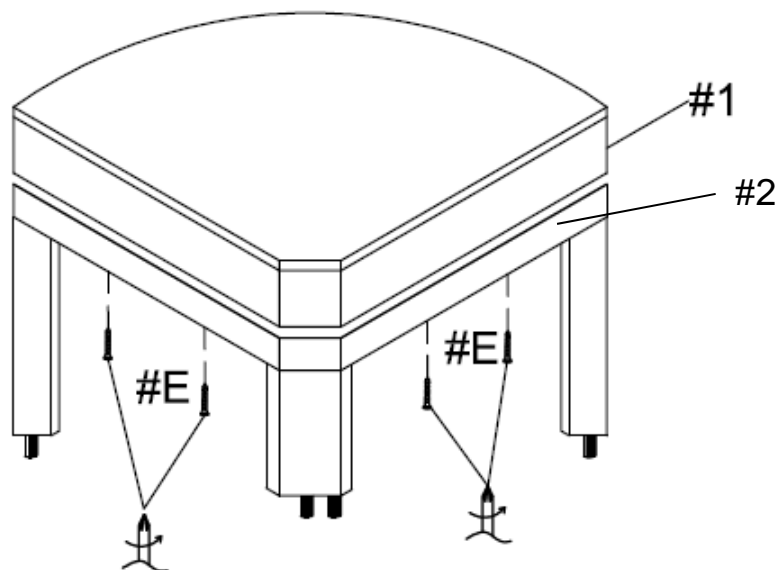

Turn right (clockwise) to tighten



#A x 3 pcs
#B x 3 pcs
#C x 3 pcs

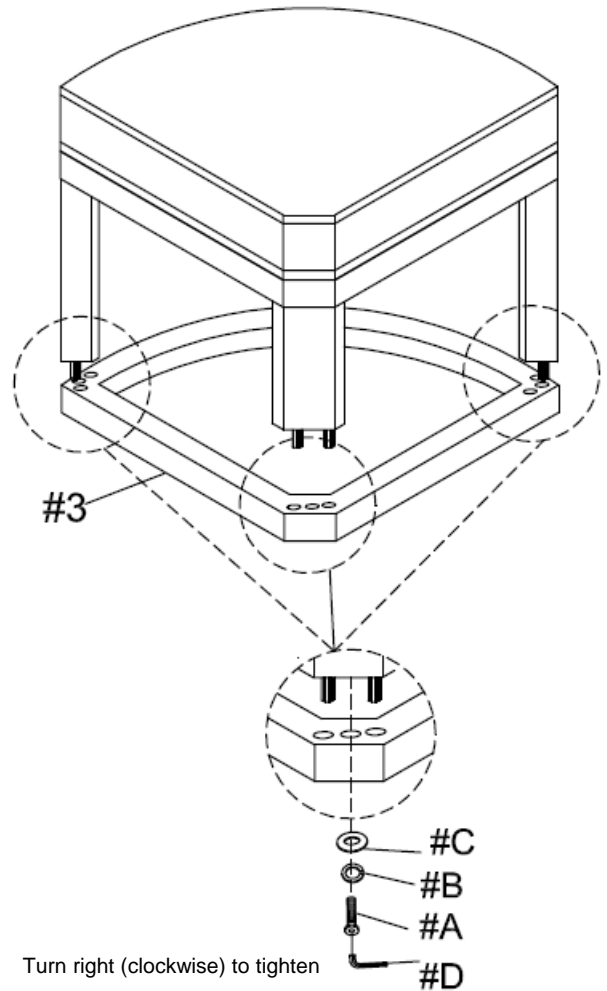

- I. Insert the assembled center leg (#4) and the side legs (#5) into the base (#3).
- II. Prepare 3 bolt assemblies by inserting FIRST the lock washer (#B) onto the bolt (#A) and then the flat washer (#C) onto the SAME bolt (#A), in that order.
- III. Insert the bolt assemblies through the pre-drilled holes on the base (#3) and secure those bolts using the Allen wrench (#D) to lock them with the assembled center leg (#4) and the side legs (#5).
- IV. Make sure the chair is rested on a flat surface and it does not feel loose or wobbly. If it does, double check that the bolts/screws are secured and properly tighten.

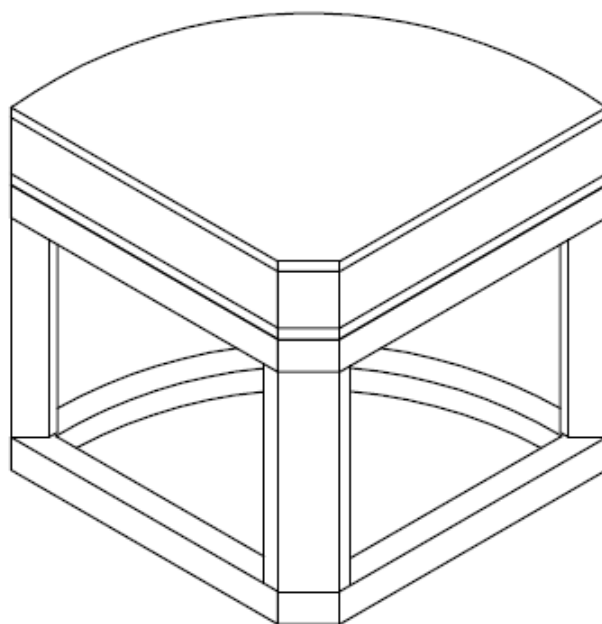

ASSEMBLE EVERYTHING EXACTLY THE SAME FOR THE OTHER THREE CHAIRS.